

PNP Silicon Switching Transistor

SXT 2907 A

- High current gain: 0.1 mA to 500 mA
- Low collector-emitter saturation voltage



Type	Marking	Ordering Code (tape and reel)	Pin Configuration			Package ¹⁾
			1	2	3	
SXT 2907 A	2F	Q68000-A8300	B	C	E	SOT-89

Maximum Ratings

Parameter	Symbol	Values	Unit
Collector-emitter voltage	V_{CE0}	60	V
Collector-base voltage	V_{CB0}	60	
Emitter-base voltage	V_{EB0}	5	
Collector current	I_C	600	mA
Total power dissipation, $T_s = 120\text{ °C}$	P_{tot}	1	W
Junction temperature	T_j	150	°C
Storage temperature range	T_{stg}	- 65 ... + 150	

Thermal Resistance

Junction - ambient ²⁾	$R_{th\ JA}$	≤ 90	K/W
Junction - soldering point	$R_{th\ JS}$	≤ 30	

¹⁾ For detailed information see chapter Package Outlines.

²⁾ Package mounted on epoxy pcb 40 mm × 40 mm × 1.5 mm/6 cm² Cu.

Electrical Characteristics

at $T_A = 25\text{ °C}$, unless otherwise specified.

Parameter	Symbol	Values			Unit
		min.	typ.	max.	

DC characteristics

Collector-emitter breakdown voltage $I_C = 10\text{ mA}$	$V_{(BR)CE0}$	60	–	–	V
Collector-base breakdown voltage $I_C = 10\text{ }\mu\text{A}$	$V_{(BR)CB0}$	60	–	–	
Emitter-base breakdown voltage $I_E = 10\text{ }\mu\text{A}$	$V_{(BR)EB0}$	5	–	–	
Collector-base cutoff current $V_{CB} = 60\text{ V}, I_E = 0$ $V_{CB} = 60\text{ V}, I_E = 0, T_A = 125\text{ °C}$	I_{CB0}	– –	– –	10 10	nA μA
Collector cutoff current $V_{CE} = 30\text{ V}, V_{BE} = 0.5\text{ V}$	I_{CEX}	–	–	50	nA
Emitter-base cutoff current $V_{EB} = 3\text{ V}, I_C = 0$	I_{EB0}	–	–	10	
Base cutoff current $V_{CE} = 30\text{ V}, V_{BE} = 3\text{ V}$	I_{BL}	–	–	50	
DC current gain $I_C = 100\text{ }\mu\text{A}, V_{CE} = 10\text{ V}$ $I_C = 1\text{ mA}, V_{CE} = 10\text{ V}$ $I_C = 10\text{ mA}, V_{CE} = 10\text{ V}$ $I_C = 150\text{ mA}, V_{CE} = 10\text{ V}$ $I_C = 500\text{ mA}, V_{CE} = 10\text{ V}$	h_{FE}	75 100 100 100 50	– – – – –	– – – 300 –	–
Collector-emitter saturation voltage ¹⁾ $I_C = 150\text{ mA}, I_B = 15\text{ mA}$ $I_C = 500\text{ mA}, I_B = 50\text{ mA}$	V_{CEsat}	– –	– –	0.4 1.6	V
Base-emitter saturation voltage ¹⁾ $I_C = 150\text{ mA}, I_B = 15\text{ mA}$ $I_C = 500\text{ mA}, I_B = 50\text{ mA}$	V_{BEsat}	– –	– –	1.3 2.0	

¹⁾ Pulse test conditions: $t \leq 300\text{ }\mu\text{s}$, $D \leq 2\%$.

Electrical Characteristics

at $T_A = 25\text{ }^\circ\text{C}$, unless otherwise specified.

Parameter	Symbol	Values			Unit
		min.	typ.	max.	

AC characteristics

Transition frequency $I_C = 50\text{ mA}$, $V_{CE} = 20\text{ V}$, $f = 100\text{ MHz}$	f_t	200	–	–	MHz
Output capacitance $V_{CB} = 10\text{ V}$, $f = 1\text{ MHz}$	C_{obo}	–	–	8	pF
Input capacitance $V_{EB} = 2\text{ V}$, $f = 1\text{ MHz}$	C_{ibo}	–	–	30	
Switching times $V_{CC} = 30\text{ V}$, $V_{BE} = 0.5\text{ V}$, $I_C = 150\text{ mA}$, $I_{B1} = 15\text{ mA}$	t_d	–	–	10	ns
	t_r	–	–	40	ns
$V_{CC} = 6\text{ V}$, $I_C = 150\text{ mA}$, $I_{B1} = I_{B2} = 15\text{ mA}$	t_s	–	–	80	ns
	t_f	–	–	30	ns

Test circuits

Delay and rise time

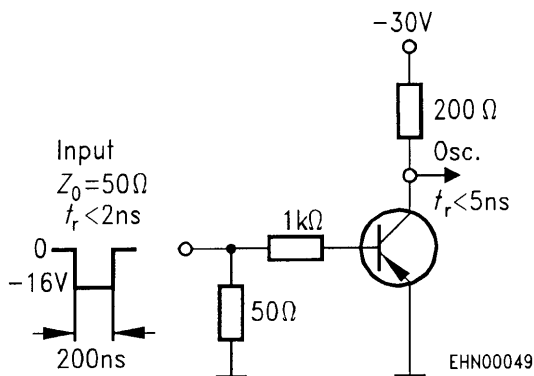

Storage and fall time

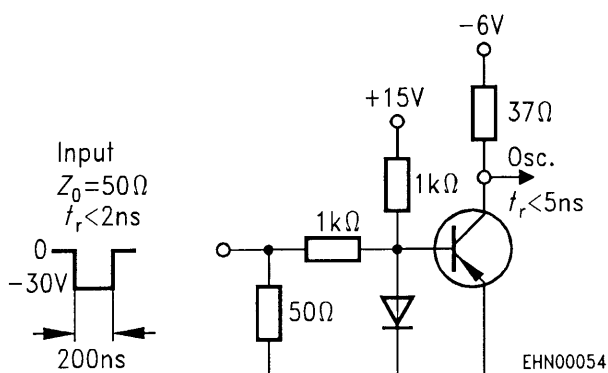

Total power dissipation $P_{tot} = f(T_A^*; T_S)$

* Package mounted on epoxy

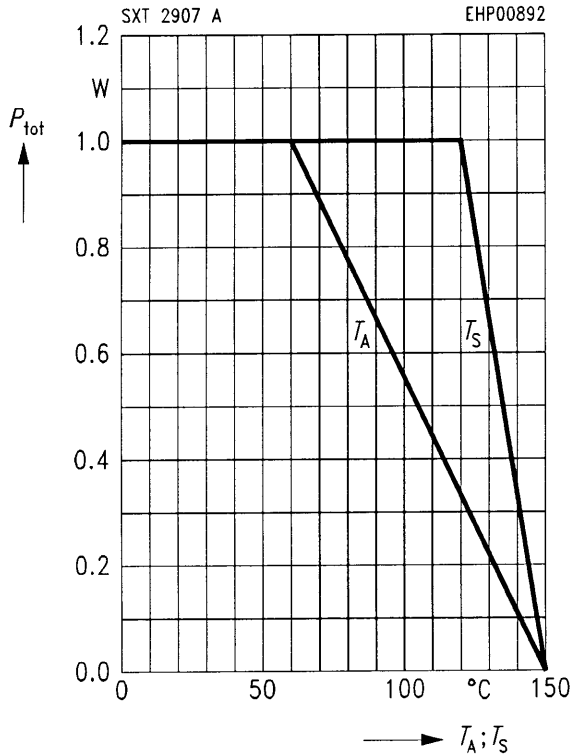

Collector-base capacitance $C_{cb} = f(V_{CB})$

$f = 1 \text{ MHz}$

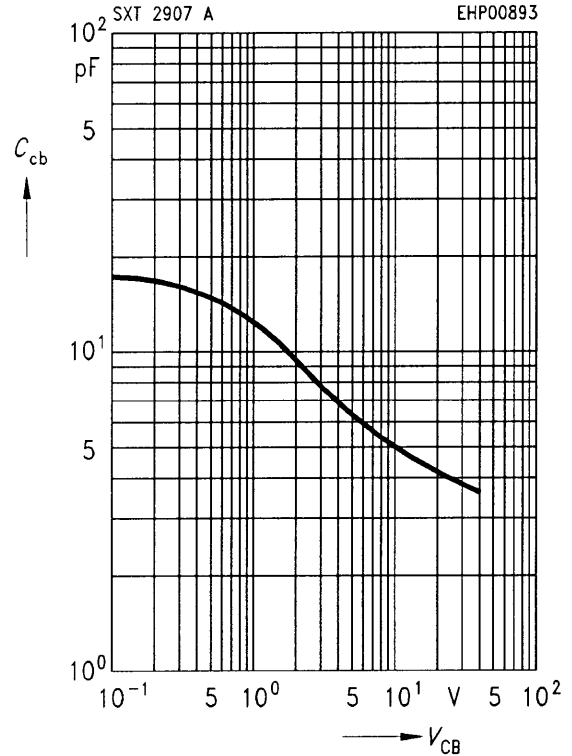

Permissible pulse load $P_{tot \text{ max}} / P_{tot \text{ DC}} = f(t_p)$

Transition frequency $f_T = f(I_C)$

$V_{CE} = 20 \text{ V}$

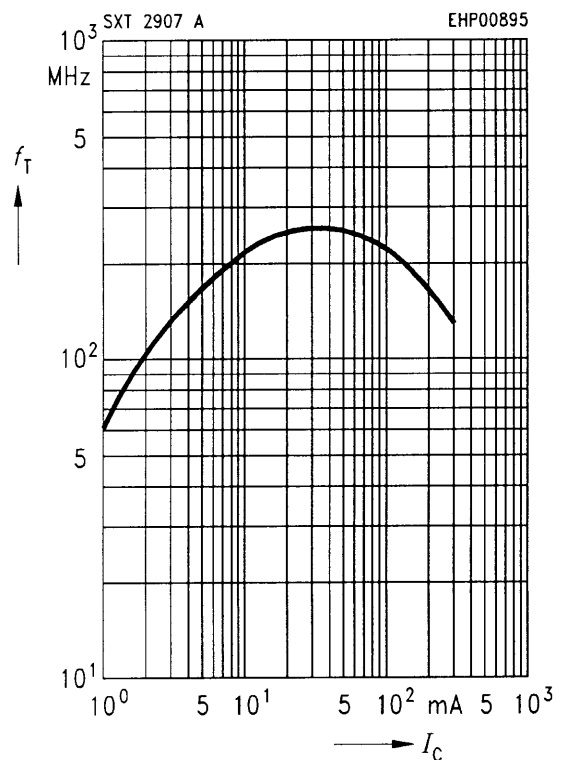
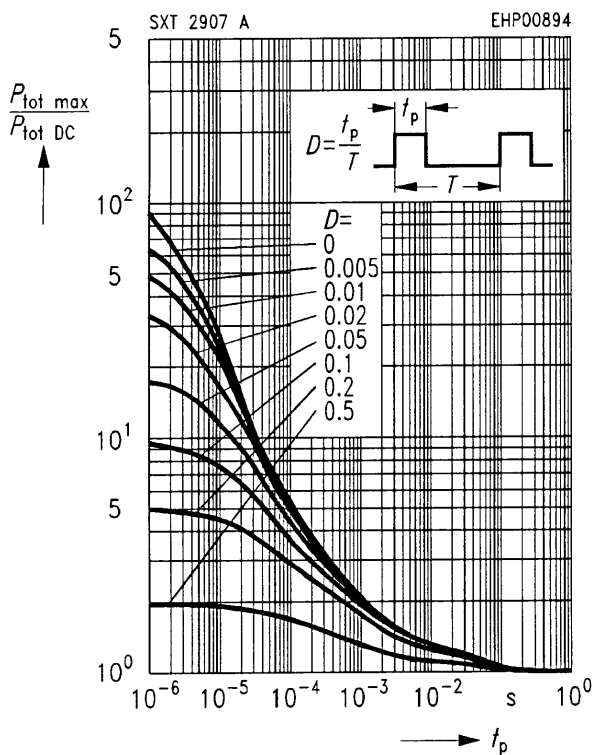

Saturation voltage $I_C = f(V_{BE\ sat}, V_{CE\ sat})$
 $h_{FE} = 10$

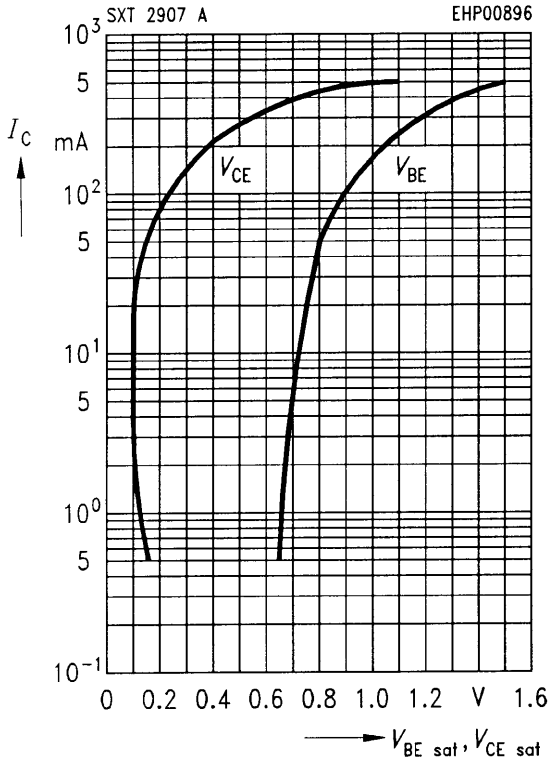

Delay time $t_d = f(I_C)$
Rise time $t_r = f(I_C)$
 $h_{FE} = 10$

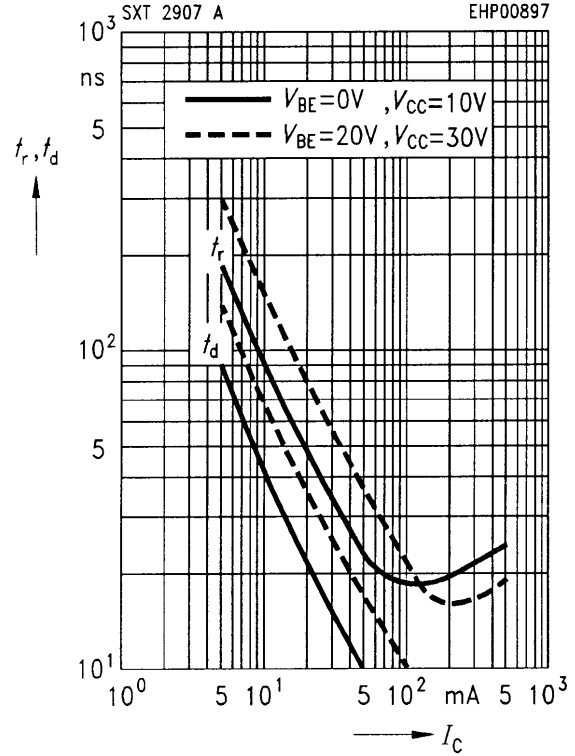

Storage time $t_s = f(I_C)$

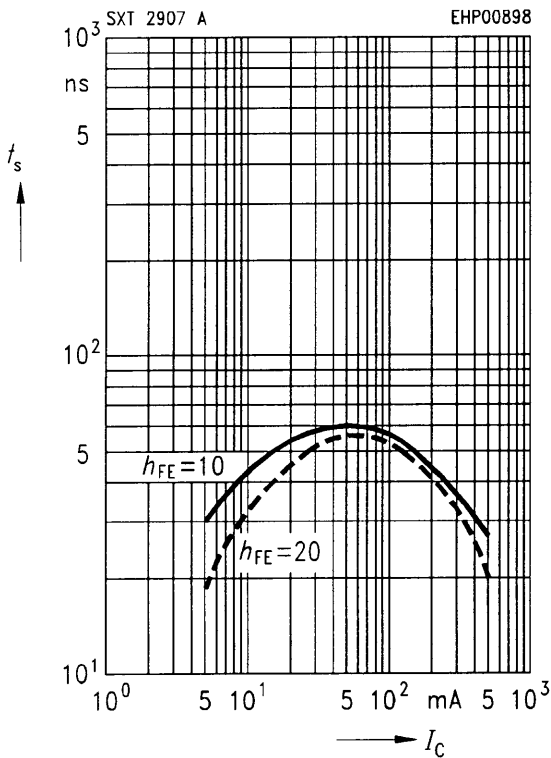

Fall time $t_f = f(I_C)$

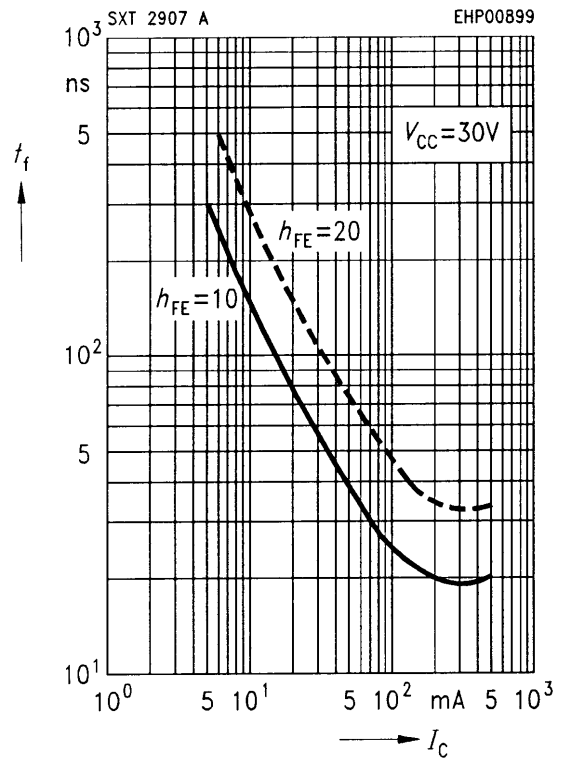

DC current gain $h_{FE} = f(I_C)$

