

GENERAL DESCRIPTION

The S1A0067X01 is a two channel power amplifier with 4.6W typical output on 12.0V Vcc.

It's typical output is 4.6W on VCC = 12.0V. There is no needs of a bootstrap-capacitor due to the use of V-PNP for a power transitory.

So, it is an advantage for making a whole system. It has an additional stand-by function, the pop noise on switc hing it's mute function is much reduced.

The S1A0067X01 has the built-in thermal protection function with hysterisys in order to protect a blocking oscillation in a short period due to a repeated protection switching on over-heating of IC.

The S1A0067X01 has a built-in output-vcc or output-gnd short protection function.

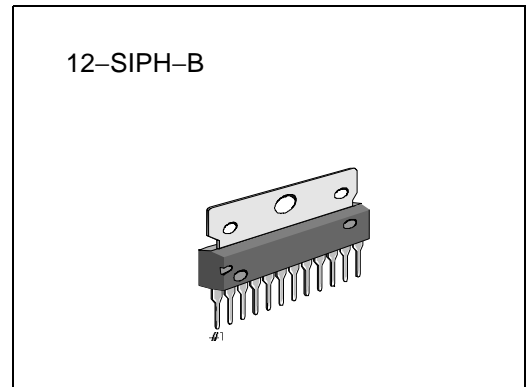

FEATURES

- Two channel 4.6W power Amp (Vcc = 12.0V)
- High power with non bootstrap capacitor
- Mute function
- Stand-by function: 100uA
- Very low pop noise, when mute on/off
- Wide operation voltage: 6.0V – 18.0V
- Include thermal protection with hysteresis
- Output-Vcc, output-GND short protection

ORDERING INFORMATION

Device	Package	Operation Temperature
S1A0067X01-X0B0	12-SIPH-B	-25 – +75°C

PIN DESCRIPTION

Terminal		Type	Description
Name	No.		
Vcc	3, 12	Vcc, PVCC	Power supply
GND	9	GND	Ground
INPUT 1,2	6, 7	INPUT	Input
NF 1,2	5, 8	NF	Pin for negative feedback capacitor
OUTPUT 1, 2	2, 10	OUTPUT	Output
RR	4	RR	Pin for ripple rejection
STAND-BY	11	ST	Pin for stand-by mode
MUTE	1	MT	Pin for mute function control

BLOCK DIAGRAM

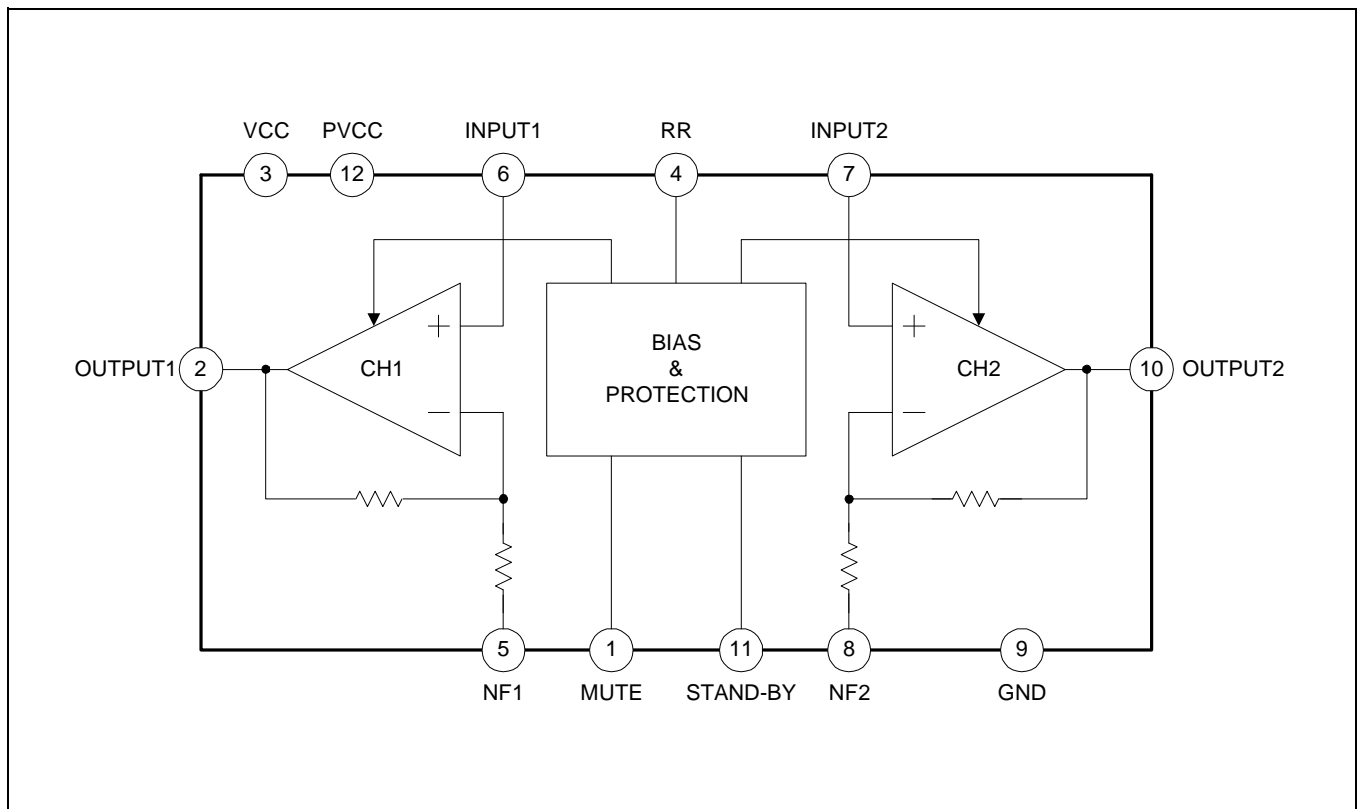

PIN CONFIGURATION

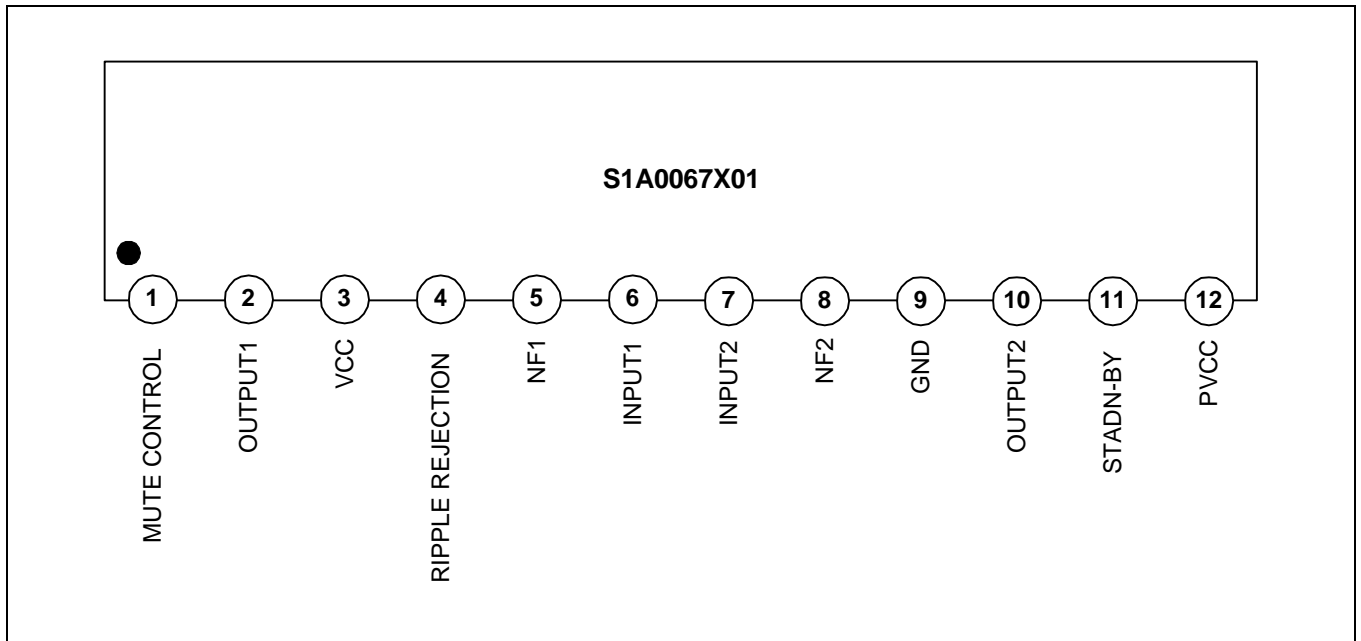

ABSOLUTE MAXIMUM RATINGS

Parameter	System	Ratings	Unit
Maximum supply voltage	VCCmax	18	V
Maximum supply current	Ipeak	2.5	A
Power Dissipation	Pd	12.5	W
Operating temperature	Topr	- 12 — 75	°C
Storage temperature	Tstg	- 40 — 150	°C

ELECTRICAL CHARACTERISTICS

(Ta = 25C, Vcc = 9V, RL = 4Ω, f = 1kHz, RG = 600Ω, unless otherwise specified)

Parameter	Symbol	condition	Spec			Unit
			Min.	Typ.	Max.	
Supply Current	Icc	Vi = 0	–	20	45	mA
Standby Current	I _{sb}	V _{pin11} = 0	–	–	100	μA
Maximum Power	Po1	THD = 10%	2.0	2.5	–	W
	Po2	THD 10%, Vcc = 12.0V	4.0	4.6	–	W
THD	THD	Po = 1W	–	0.1	0.9	%
Voltage Gain	AV1	Rf = 51Ω, Vo = 0.775V	38	40	42	dB
	AV2	Rf = 0Ω, Vo = 0.775V	44	46	48	dB
Channel Balance	CB	Rf = 0Ω, Vo = 0.775V	– 2.0	0.0	2.0	dB
Input Resistance	Ri	–	32	40	48	kΩ
Output Noise	Vno	Rg = 10Ω, BW = 20 — 20kHz	–	0.2	1.0	mVrms
Ripple Rejection Ratio	RR	Rg = 600Ω, f = 120kHz	46	–	–	dB
Channel Crossover Ratio	CT	Rg = 10Ω, f = 1kHz, Vo = 0dBm	40	–	–	dB
Standby Changing Voltage	Vsb	–	0	–	0.9	V
Mute Changing Voltage	Vmt	–	0	–	0.25	V
Mute Attenuation Ratio	Rmt	V _{pin1} = 0	–	–	-60	dB

APPLICATION CIRCUIT

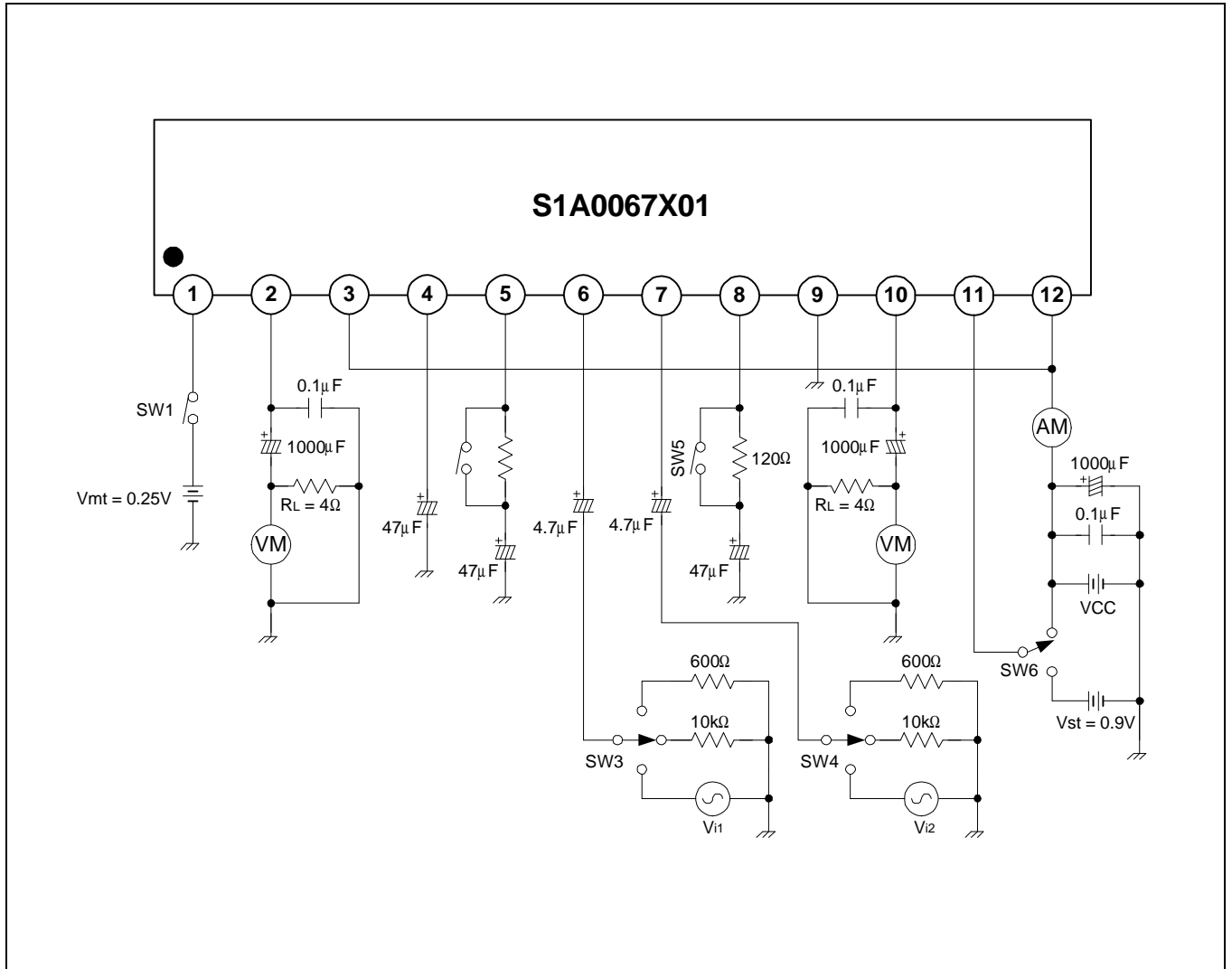

APPLICATION CIRCUIT 1

