

INTRODUCTION

The KA2213 is a monolithic integrated circuit consisting of a preamplifier, ALC circuit, and power amplifier in a 14-pin plastic dual-in-line package with heat sink.

FEATURES

- Suitable for playing and recording functions of mono cassette tape recorders
- Wide operating supply voltage range: $V_{CC} = 4V \sim 12V$
- High gain pre-amplifier and power amplifier
- Output power of power amplifier state
 $P_O = 1W$ at $V_{CC} = 6V$, $R_L = 4\Omega$, THD =10%
- Soft tone quality at the time of output saturation
- Wide ALC range and small variation in output voltage
- Reduced shock noise at the time of power on/off due to built-in prevention circuit
- Variable monitor capability due to recording amplifier consisting of pre-amplifier alone
- Minimum number of external parts required

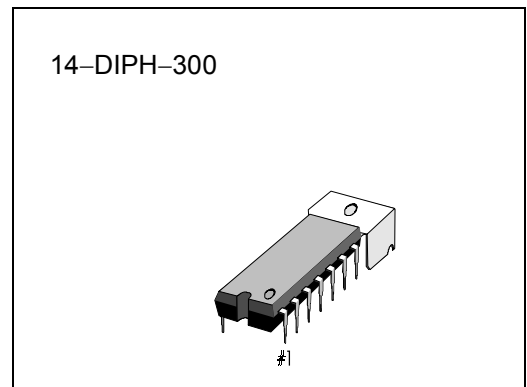

ORDERING INFORMATION

Device	Package	Operating Temperature
KA2213	14-DIPH-300	-20°C ~ +70°C

BLOCK DIAGRAM

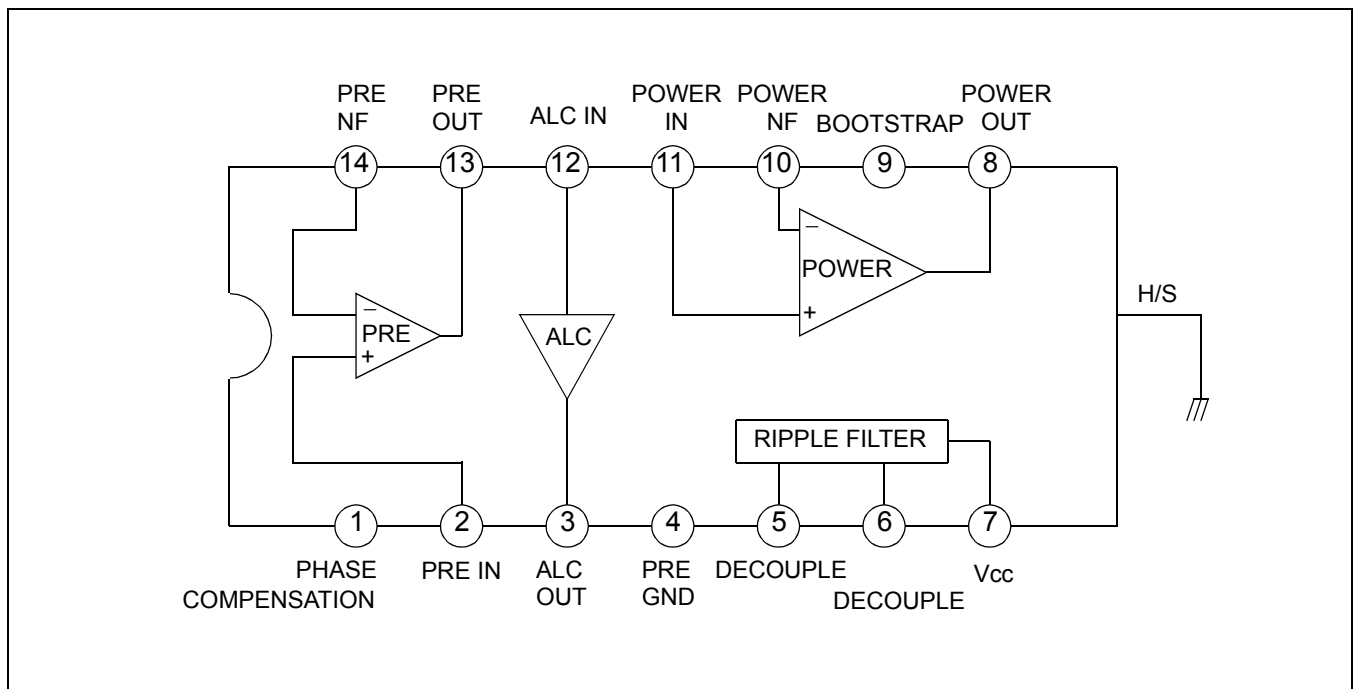

Figure 1.

ABSOLUTE MAXIMUM RATINGS (Ta = 25°C)

Characteristic	Symbol	Value	Unit
Supply Voltage	V _{CC}	13	V
Power Dissipation	P _D	1.2 (2.25*)	W
Operating Temperature	T _{OPR}	- 20 ~ + 70	°C
Storage Temperature	T _{STG}	- 40 ~ +150	°C

* Mounted and soldered on a 50mm x 50mm copper foil of PCB

ELECTRICAL CHARACTERISTICS

(Ta = 25°C, Vcc = 6V, f = 1kHz, unless otherwise specified)

Characteristic	Symbol	Test Conditions	Min.	Typ.	Max.	Unit
Quiescent Circuit Current	I _{CCQ}	V _{CC} = 6V, V _I = 0	–	18	30	mA
		V _{CC} = 9V, V _I = 0	–	23	40	mA
Pre-Amplifier						
Open Loop Voltage Gain	G _{VO}	Open loop	–	85	–	dB
Closed Loop Voltage Gain	G _{VC}	Closed loop, Play	–	40	–	dB
Output Voltage	V _O	THD = 1%, Play	0.9	1.2	–	V
Input Resistance	R _I	–	21	30	–	kΩ
Equivalent Input Noise Voltage	V _{NI}	Play	–	1.0	2.0	μV
ALC Input Level	V _{I (ALC)}	THD = 1%, Rec	– 20	– 12	–	dBm
Power Amplifier						
Closed Loop Voltage Gain	G _{VC}	R _F = 51Ω	43	45	47	dB
Output Power	P _O	V _{CC} = 6V, R _L = 4Ω, THD = 10%	0.7	1.0	–	W
		V _{CC} = 7.5V, R _L = 4Ω, THD = 10%	1.0	1.5	–	W
		V _{CC} = 9V, R _L = 4Ω, THD = 10%	1.7	2.2	–	W
Total Harmonic Distortion	THD	P _O = 250mW	–	0.3	1.5	%
Input Resistance	R _I	–	–	30	–	kΩ
Output Noise Voltage	V _{NO}	R _G = 10kΩ	–	0.6	1.8	mV
Ripple Rejection Ratio	RR	R _G = 0Ω, V _R = 150mV, f = 100Hz	40	45	–	dB

TEST CIRCUIT

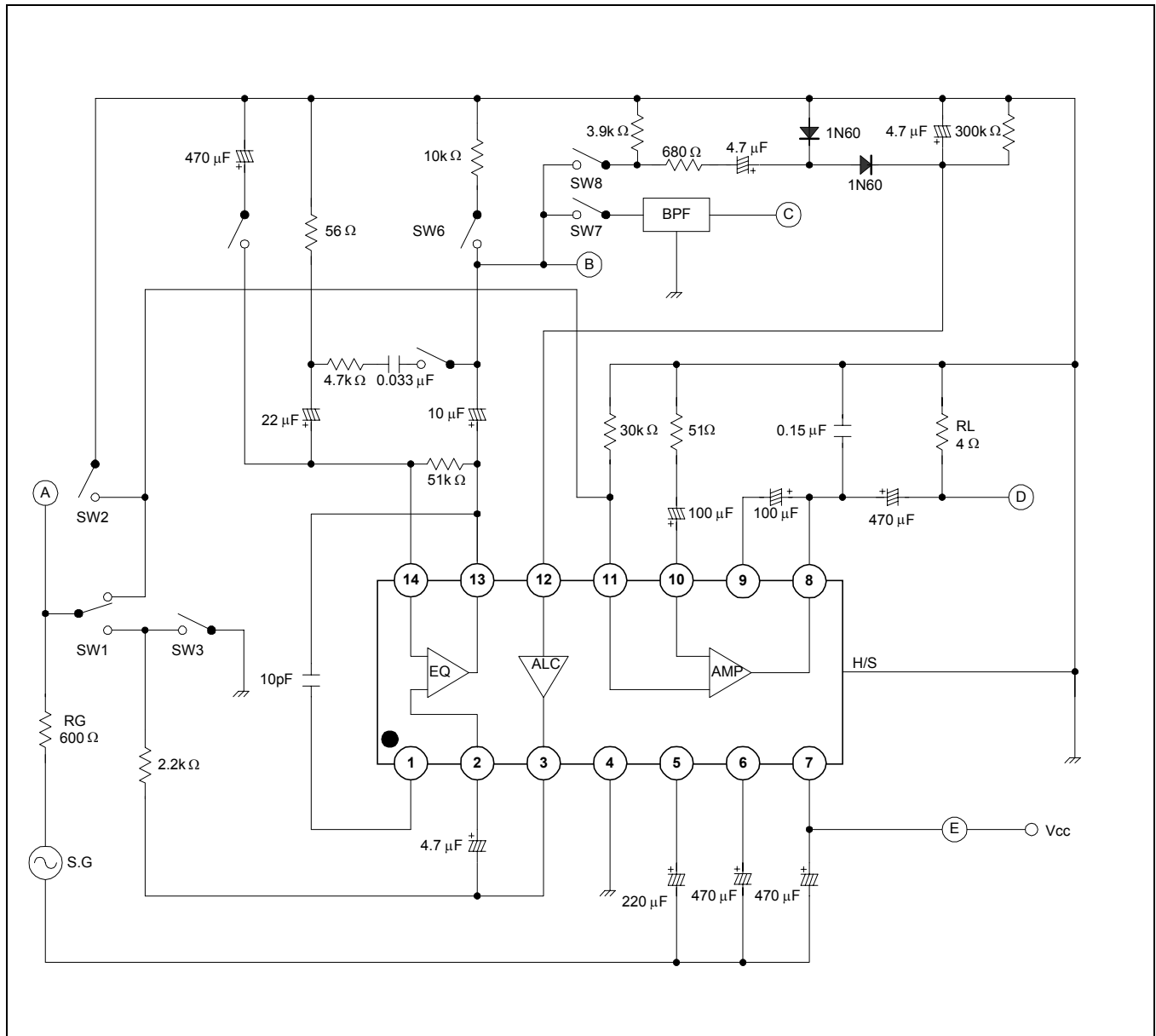

Figure 2.

TEST METHOD

Characteristic	SW1	SW2	SW3	SW4	SW5	SW6	SW7	SW8	Test Point	Test Method	
Power Amplifier	I_{CCQ}		on	on	off	on	on	off	off	E	Test circuit current
	G_{VC}	2	off	off	off	on	on	off	off	A.D	$G_{VC} = 20 \log V_O/V_I$ (dB)
	P_O	2	off	off	off	on	on	off	off	D	Test output voltage at THD = 10%
	THD	2	off	off	off	on	on	off	off	D	Test THD at output voltage $V_O = 1V$
	V_{NO}		on	off	off	on	on	off	off	D	Test output noise voltage
	RR		on	off	off	on	on	off	off	D	RR = $20 \log V_{RO}/150$ (dB) Test output ripple voltage (VRO)
Pre-Amplifier	G_{VO}	1	off	off	on	off	on	off	off	A.B	$G_{VO} = 20 \log V_O/V_I$ (dB)
	V_O	1	off	off	off	on	on	off	off	B	Test output voltage at THD = 1%
	V_{NI}		off	on	off	on	on	on	off	C	Convert output noise voltage at $R_G = 2.2k\Omega$, $V_{NI} = V_{NO}/G_V$
	$V_{I(ALC)}$	1	off	off	off	off	off	off	on	A.B	Test input voltage at THD = 1%

TYPICAL APPLICATION CIRCUITS

Mono Cassette Tape Recorder

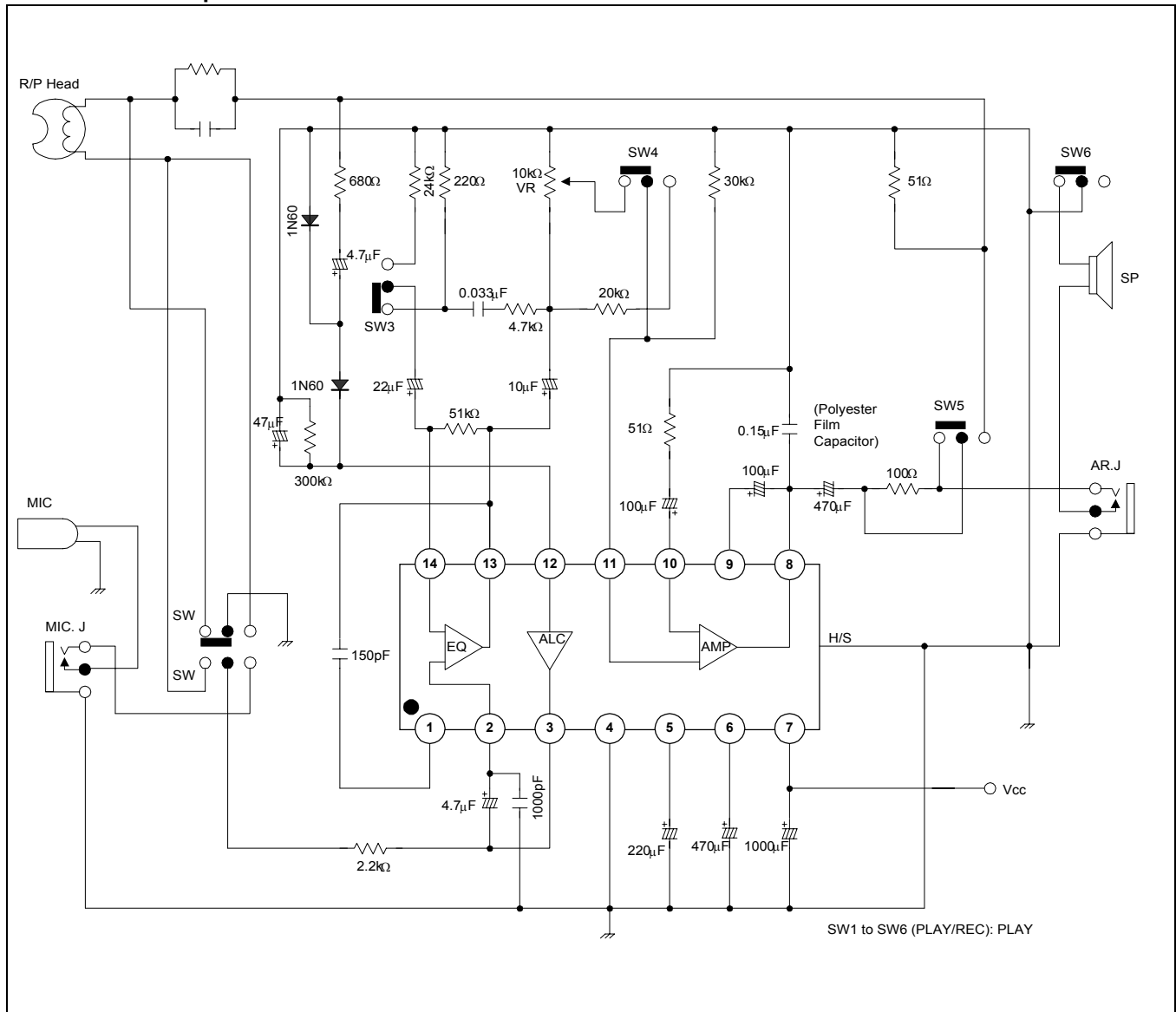

Figure 3.

Radio Cassette Tape Recorder

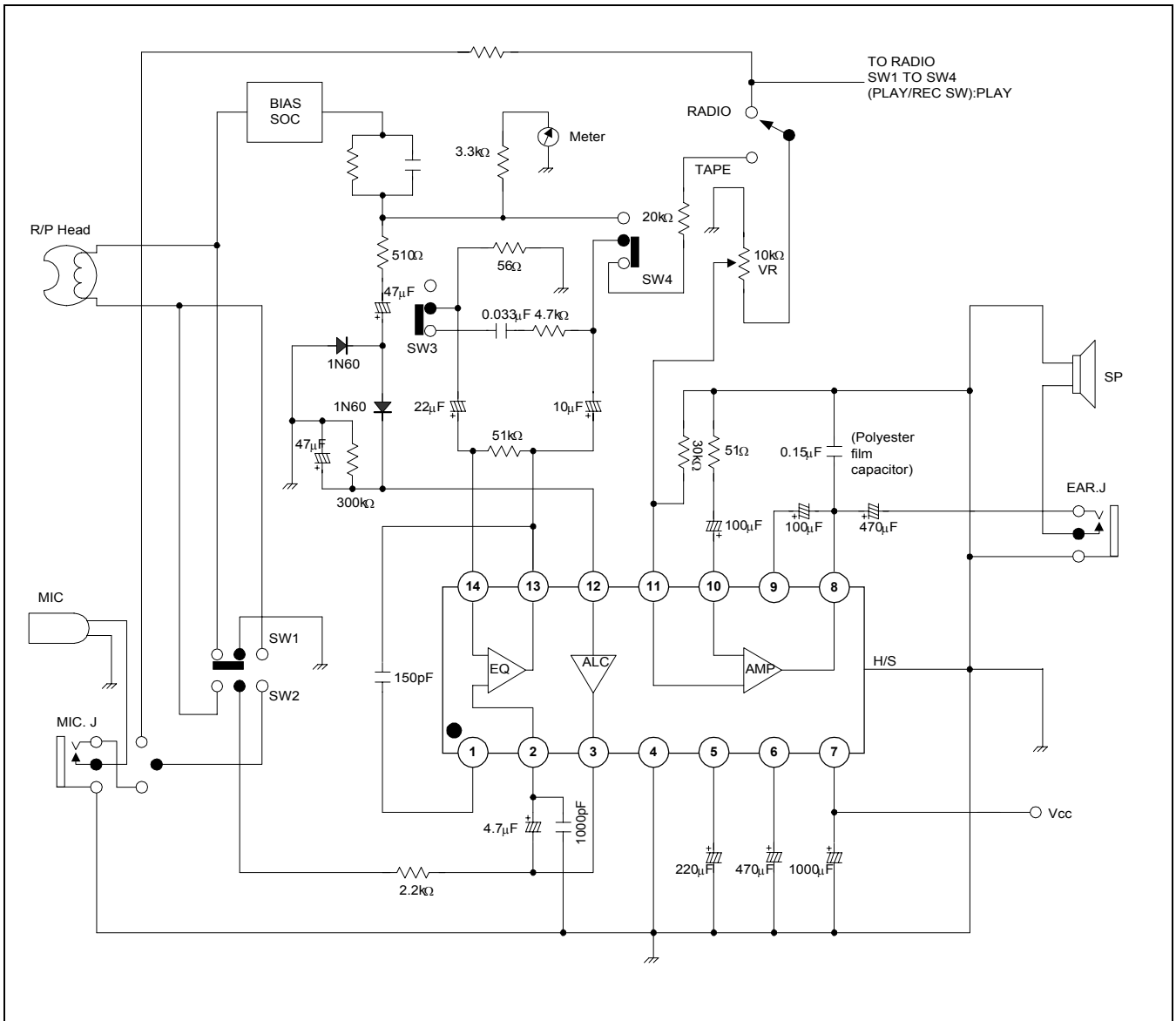

Figure 4.

NOTES