

GENERAL DESCRIPTION

KS7306 is a CCD digital signal processor.

The electronic video signal that passed the color filter array(CFA) pattern of CCD is put to the process of dual correlation sampling and then converted to digital video signal by A/D converter.

Taking the digital video signal so processed as an input, KS7306 performs luminance and chroma signal process and finally outputs signals encoded to NTSC/PAL broadcast standards, and generates detection signals for AE/AF/AWB.

100-QFP-1414

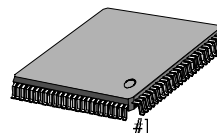

ORDERING INFORMATION

Device	Package	Operating Temperature
KS7306	100-QFP-1414	0 ~ 70 °C

FEATURES

- Offers 10 bit input digital signal processing.
- Carries built-in 2H line memory.(10bit 1024)
- Performs Y signal processing.
- Performs C signal processing.
- Carries an encoder capable to NTSC/PAL dual form application.
- Carries built-in Y/C 2-channal DA converter.
- Carries built-in AE/AF/AWB detection system.
- Provides micom parallel interface.
- Micom capable to control variable parameters.
- Offers digital effects interfacing
- Suites Hi8/Normal CCD application.
- Suites 470K,520K,570K and 620K CCD controlled EIS system application.
- Supports 16:9 aspect wide TV (full mode) application.

APPLICATIONS

CCD camera (camcorder, CCTV, digital still camera, etc.).

PIN CONFIGURATION

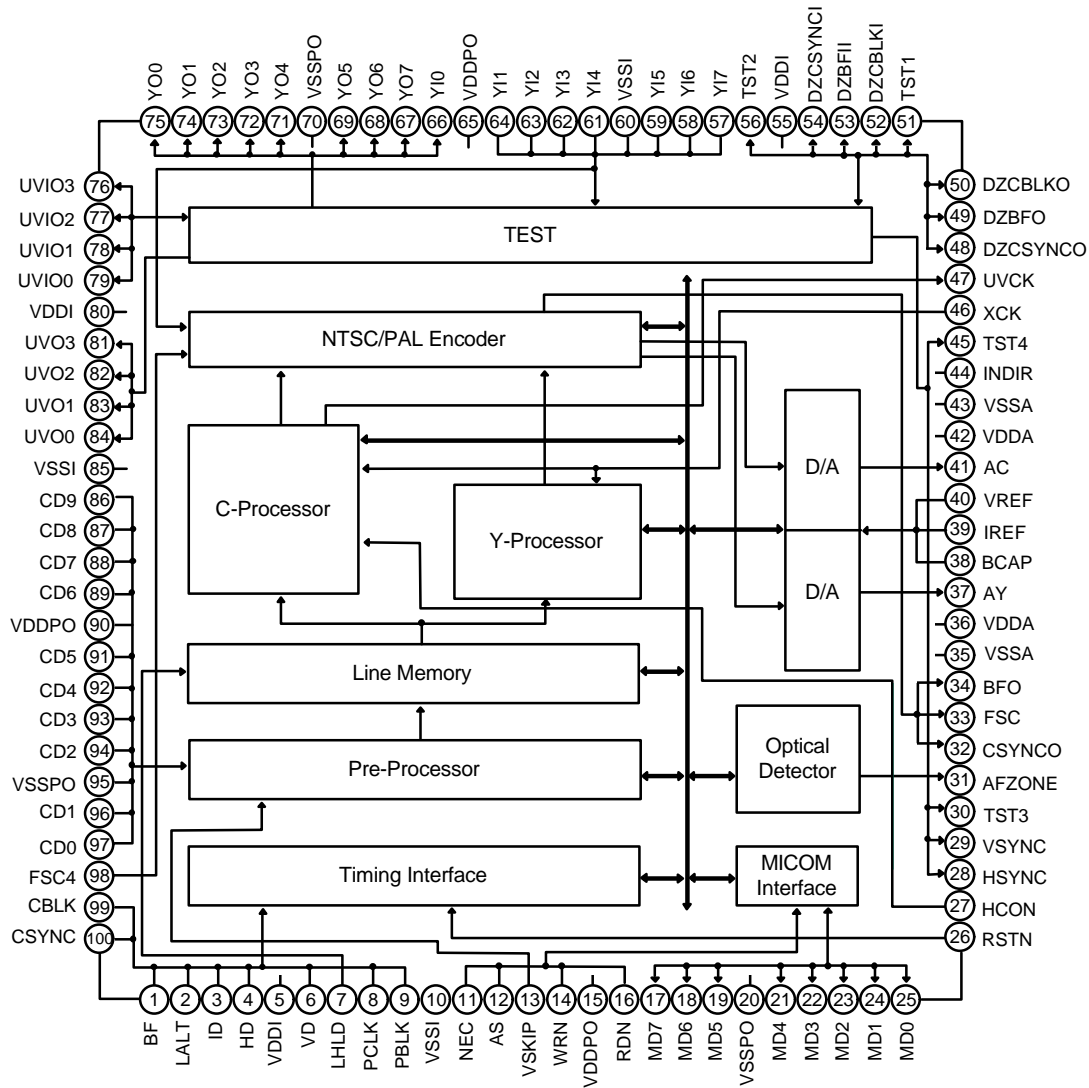

PIN DESCRIPTION

NO.	Symbol	I/O	Description
1	BF	I	Burst Flag
2	LALT	I	Line Alternation for PAL System
3	ID	I	Line Identifier
4	HD	I	Horizontal Driving Pulse
5	VDDI	P	Power Supply for Internal Logic
6	VD	I	Vertical Driving Pulse
7	LHLD	I	Line Hold Signal
8	PCLK	I	System Clock
9	PBLK	I	Pre-Blanking Pulse
10	VSSI	G	Ground for Internal Logic
11	NEC	I	Ext. Micom select (NEC/SAM 8*)
12	AS	I	Address Strobe for Micom I/F
13	VSKIP	I	Vertical Skip Pulse
14	WRN	I	Write Enable (Active Low) for Micom I/F
15	VDDPO	P	Power Supply for Input & Output PAD
16	RDN	I	Read Enable (Active Low) for Micom I/F
17	MD7	I/O	Micom Address & Data Port 7
18	MD6	I/O	Micom Address & Data Port 6
19	MD5	I/O	Micom Address & Data Port 5
20	VSSPO	G	Ground for Input & Output Pad
21	MD4	I/O	Micom Address & Data Port 4
22	MD3	I/O	Micom Address & Data Port 3
23	MD2	I/O	Micom Address & Data Port 2
24	MD1	I/O	Micom Address & Data Port 1
25	MD0	I/O	Micom Address & Data Port 0
26	RSTN	I	System Reset (Active Low)
27	HCON	I	Horizontal Sync. Signal (S1,S2 Control)
28	HSYNC	O	Horizontal Sync. Signal
29	VSNC	O	Vertical Sync. Signal
30	TST3	O	Test Output 3
31	AFZONE	O	Auto Focus Window Zone Pulse
32	CSYNCO	O	Composite Sync. Output (Processor Delay Matched Signal)
33	FSC	O	Color Subcarrier Signal
34	BFO	O	Burst Flag Output (Processor Delay Matched Signal)
35	VSSA	AG	Analog Ground

(Continued)

NO.	Symbol	I/O	Description
36	VDDA	AP	Analog Power
37	AY	O	D/A Converted Luminance Signal
38	BCAP	I	Bypass Capacitor Port for D/A Converter
39	IREF	I	Current Source Reference Port D/A Converter
40	VREF	I	Voltage Source Reference Port D/A Converter
41	AC	O	D/A converted Chroma Signal
42	VDDA	AP	Analog Power
43	VSSA	AG	Analog Ground
44	INDIR	I	Input Mode Select for I/O Bidirectional Pin
45	TST4	O	Test Output 4
46	XCK	I	External Clock for Multimedia PC
47	UVCK	O	R-Y / B-Y Identifier
48	DZCSYNCO	I/O	Delay Matched Composite Sync. Output for Digital Zoom or Test I/O
49	DZBFO	I/O	Delay Matched Burst Flag Output for Digital Zoom or Test I/O
50	DZCBLKO	I/O	Delay Matched Composite Blank Output for Digital Zoom or Test I/O
51	TST1	I/O	Test I/O
52	DZCBLKI	I/O	Delay Matched Composite Blank input for Digital Zoom or Test I/O
53	DZBFI	I/O	Delay Matched Burst Flag input for Digital Zoom or Test I/O
54	DZCSYNCI	I/O	Delay Matched Composite Sync. input for Digital Zoom or Test I/O
55	VDDI	P	Power Supply for Internal Logic
56	TST2	I/O	Test I/O
57	Y17	I	Digital Zoom Processed Luminance Input 7
58	Y16	I	Digital Zoom Processed Luminance Input 6
59	Y15	I	Digital Zoom Processed Luminance Input 5
60	VSSI	G	Ground for Internal Logic
61	Y14	I	Digital Zoom Processed Luminance Input 4
62	Y13	I	Digital Zoom Processed Luminance Input 3
63	Y12	I	Digital Zoom Processed Luminance Input 2
64	Y11	I	Digital Zoom Processed Luminance Input 1
65	VDDPO	P	Power Supply for Input / Output Pad
66	Y10	I	Digital Zoom Processed Luminance Input 0
67	YO7	O	Luminance Output 7 for Digital Zoom
68	YO6	O	Luminance Output 6 for Digital Zoom
69	TO5	O	Luminance Output 5 for Digital Zoom
70	VSSPO	G	Ground for Input & Output Pad
71	YO4	O	Luminance Output 4 for Digital Zoom
72	YO3	O	Luminance Output 3 for Digital Zoom

(Continued)

NO.	Symbol	I/O	Description
73	YO2	O	Luminance Output 2 for Digital Zoom
74	YO1	O	Luminance Output 1 for Digital Zoom
75	YO0	O	Luminance Output 0 for Digital Zoom
76	UVIO3	I/O	Digital Zoom Processed Chroma Input 3/4:2:2 Chroma Output 7
77	UVIO2	I/O	Digital Zoom Processed Chroma Input 2/4:2:2 Chroma Output 6
78	UVIO1	I/O	Digital Zoom Processed Chroma Input 1/4:2:2 Chroma Output 5
79	UVIO0	I/O	Digital Zoom Processed Chroma Input 0/4:2:2 Chroma Output 4
80	VDDI	P	Power for Internal Logic
81	UVO3	O	Chroma Output 3 for Digital Zoom / 4:2:2 Chroma Output 3
82	UVO2	O	Chroma Output 2 for Digital Zoom / 4:2:2 Chroma Output 2
83	UVO1	O	Chroma Output 1 for Digital Zoom / 4:2:2 Chroma Output 1
84	UVO0	O	Chroma Output 0 for Digital Zoom / 4:2:2 Chroma Output 0
85	VSSI	G	Ground for Internal Logic
86	CD9	I	CCD Data Input 9 Precessed ADC or FCM
87	CD8	I	CCD Data Input 8 Precessed ADC or FCM
88	CD7	I	CCD Data Input 7 Precessed ADC or FCM
89	CD6	I	CCD Data Input 6 Precessed ADC or FCM
90	VDDPO	P	Power Supply for Input & Output Pad
91	CD5	I	CCD Data Input 5 Precessed ADC or FCM
92	CD4	I	CCD Data Input 4 Precessed ADC or FCM
93	CD3	I	CCD Data Input 3 Precessed ADC or FCM
94	CD2	I	CCD Data Input 2 Precessed ADC or FCM
95	VSSPO	G	Ground for Input & Output Pad
96	CD1	I	CCD Data Input 1 Precessed ADC or FCM
97	CD0	I	CCD Data Input 0 Precessed ADC or FCM
98	FSC4	I	Color Subcarrier x 4
99	CBLK	I	Composite Blank Signal
100	CSYNC	I	Composte Sync. Signal

ABSOLUTE MAXIMUM RATINGS

Characteristics	Symbol	Value	Unit
Supply Voltage	V_{DD}	-0.3 to 7	V
Terminal input Voltage	V_I	-0.3 to $V_{DD} + 0.3$	V
Power Dissipation	P_D	700	mW
Operating Temperature	TORR	0 ~ +70	°C
Storage Temperature	T_{STG}	-40 ~ +125	°C
Latch-Up Current	I_{LU}	100	mA

ELECTRICAL CHARACTERISTICS**DC**

Characteristics	Symbol	Test Condition	Min	Typ	Max	Unit
Operating Voltage	V_{DD}	$T_a = 25^\circ\text{C}$	4.75	5.0	5.25	V
Input Voltage	V_{IH}	$T_a = 25^\circ\text{C}$	$0.7V_{DD}$	-	-	V
	V_{IL}	$T_a = 25^\circ\text{C}$	-	-	$0.3V_{DD}$	V
output Voltage	V_{OH}	$I_{OH} = -1\text{mA}$	2.4	-	-	V
	V_{OL}	$I_{OL} = 1\text{mA}$	-	-	0.4	V
Operating Current	I_{DD}	$V_{DD} = 5\text{V}$	-	140	160	mA
Maximum Input Leakage Current	I_{IH}	$V_I = 0 \sim V_{DD}$	-10	-	10	μA
	I_{IL}	$V_I = 0 \sim V_{DD}$	-10	-	10	μA

AC

Characteristics	Symbol	Test Condition	Min	Typ.	Max	Unit
Input Data Setup Time	T_{SU}	$V_{DD} = 5 \pm 5\%$, $T_a = 0 \sim 70^\circ\text{C}$	5	-	-	nsec
Input Data Hold Time	T_{HD}	$V_{DD} = 5 \pm 5\%$, $T_a = 0 \sim 70^\circ\text{C}$	5	-	50	nsec

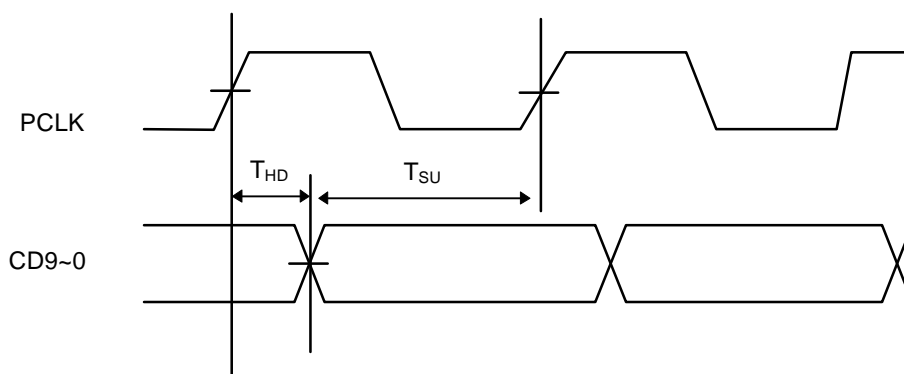

MICOM INTERFACE

1. NEC MICOM INTERFACE

Characteristics	Symbol	Min	Typ	Max	Unit
Address setup time	Tast	15	-	-	nsec
Address hold time	That	35	-	-	nsec
AS pulse width	Tasw	35	-	-	nsec
RDN pulse width	Trdw	400	-	-	nsec
WRN pulse width	Twrw	400	-	-	nsec
Data delay from RDN,WRN	Td	-	-	100	nsec
Data hold time	Tdh	0	-	-	nsec

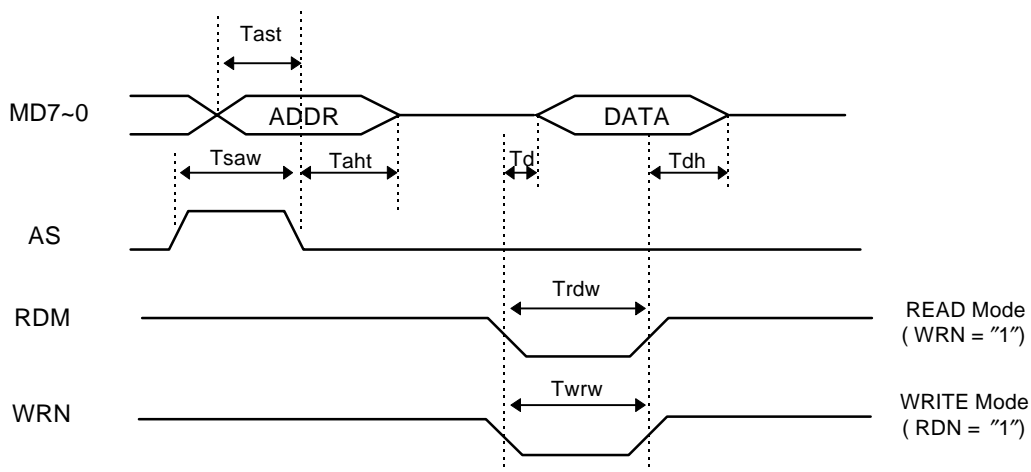

2. SAM8 MICOM INTERFACE

Characteristics	Symbol	Min	Typ	Max	Unit
Address setup time	Tast	15	-	-	nsec
Address hold time	That	35	-	-	nsec
AS pulse width	Tasw	35	-	-	nsec
RDN pulse width	Trdw	400	-	-	nsec
WRN pulse width	Twrw	400	-	-	nsec
Data delay from RDN,WRN	Td	-	-	100	nsec
Data hold time	Tdh	0	-	-	nsec

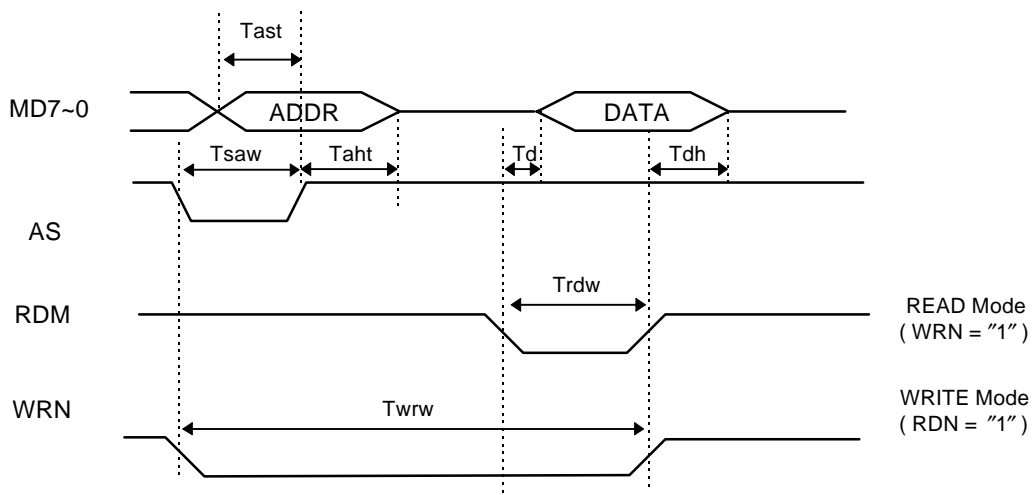

SYSTEM DESCRIPTION

The video data output from CCD go through CDS IC (KA7307) and become quantized by 10 bit ADC. For hand tremble correction in the CCD controlled gyro sensor method, the quatized video data are fed to FCM in which effective pixel section of the data gets corrected and extended, then the data are entered to the signal processor (KS7306) for YC coding so that the data are propely encoded to conform with NTSC/PAL broadcasting method.

The encoded data is converted to analog signal by the built-in DAC and output Y.C signal finally.

The camera embodies current video status detection function needed for AE/AF/AWB function as an automatic control provision of the camera system. The function of signal processing and video status detection is implemented by data communication with the micom through the parallel interfaces to allow setting of variable parameters, transmisson of detection signals, and reception of control signals that are necessary in the signal processing. The clock used in IC' s is supplied by a separate IC, the timing generator (KS7213). For the zooming, the Y,(R-Y)(B-Y) interface to the processing is provided. And the interface allows interfacing with IC' s for the option of other digital effects.

The timing generator generates time pulse and video synchronizing signal required in all functional block of the camera system. The clock supports the vertical expansion mode especially required in CCD controlled gyro sensor and electronic zooming.

Using the clock furnished by the clock generator, the digital zoom (KS7314) performs zooming by means of vertical interpolation of expanded CCD output and horizontal expansion and interpolation of the output.

In this camera system, IC' s used for FCM, gyro, microcontroller, and DZ functions respectively are the ones required only in the system that employs CCD controlled gyro sensor and electronic zooming for optional funtions while a system pursuing electronic zooming alone requires employment of DZ IC only to achieve the purpose. The CCDs of 510H (NTSC/PAL) and 760H (NTSC/PAL) allow a range of system configurations that support 470K, 520K, and 620K (wobble correction CCD) pixels. The figure below illustrates the camera system.

A/D; Analog to Digital

CCD; Charge Coupled Device

FCM; Frquency Converting Memory

DZ; Digital Camera Process

DCP; Digital Camera Process

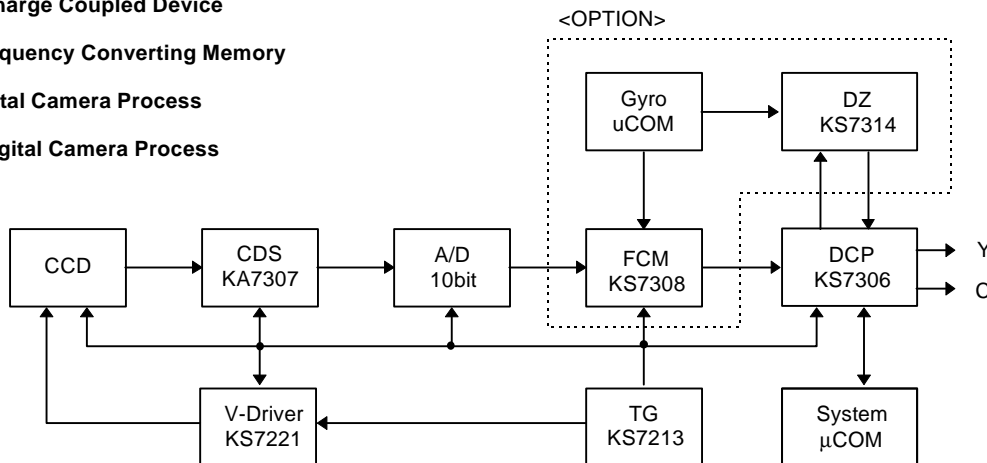

A BLOCK DIAGRAM OF CAMERA SYSTEM CONFIGURATION

BLOCK DIAGRAM

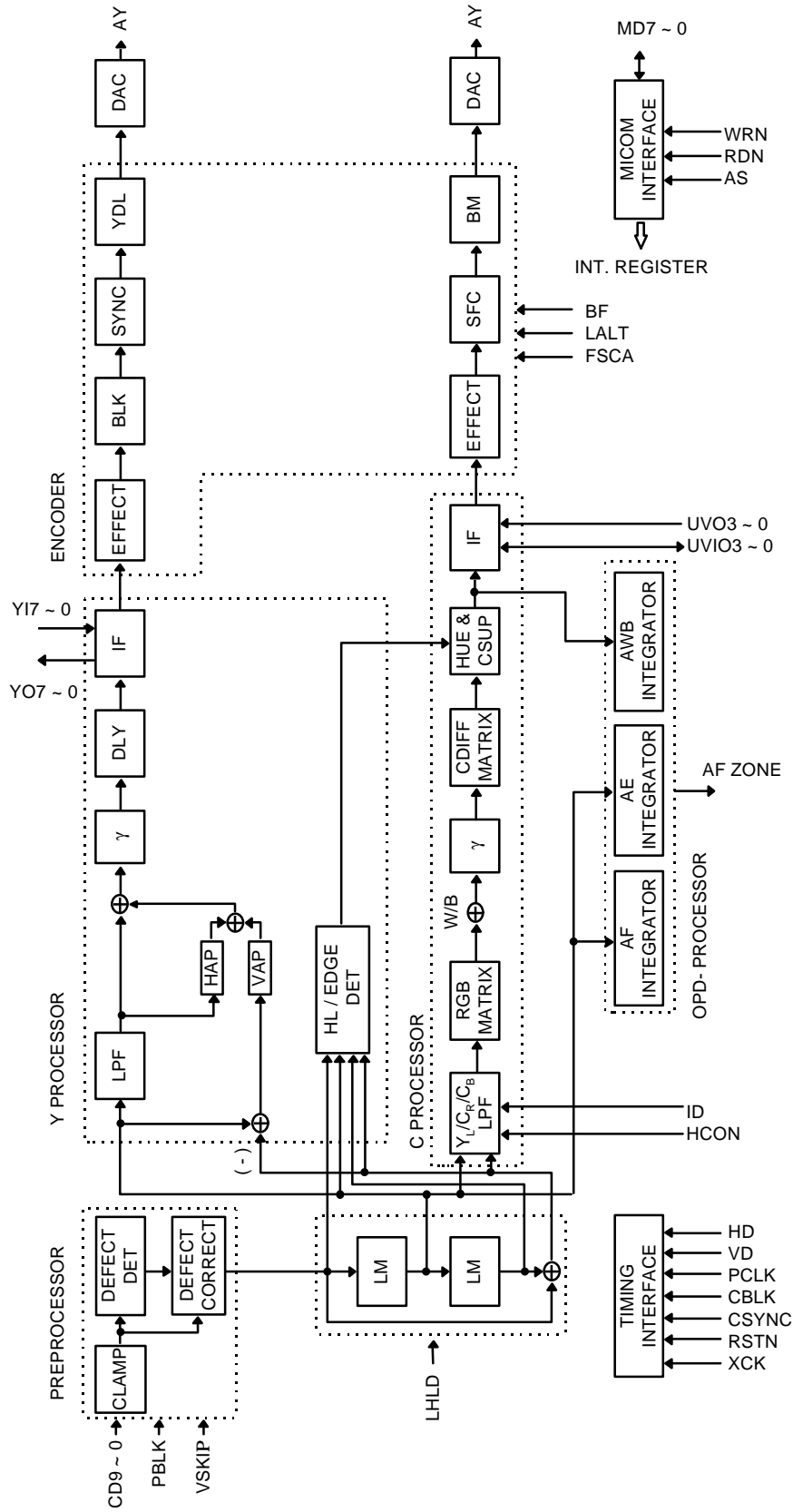

OPD-PROCESSOR BLOCK DIAGRAM

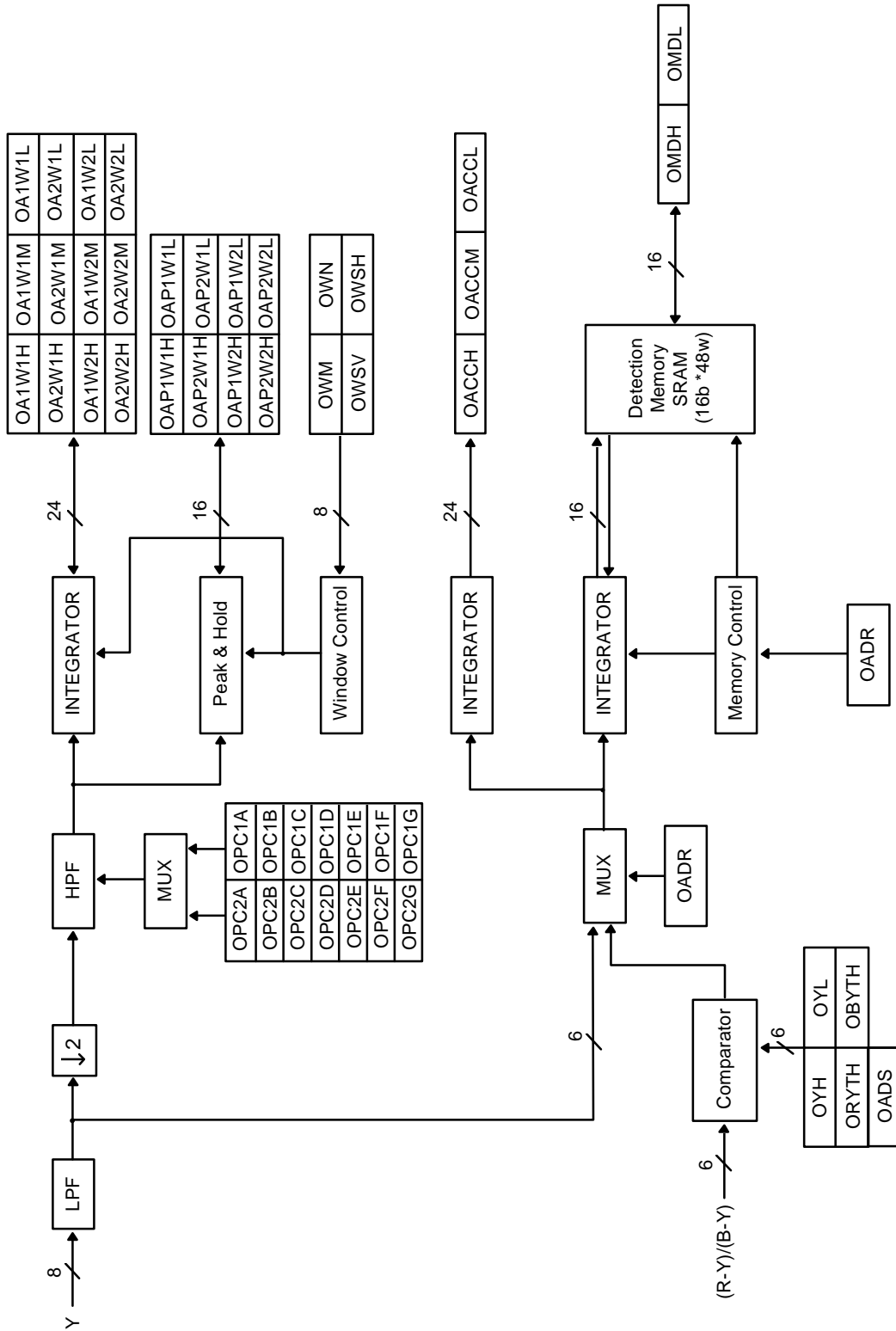

OPERATION OF BLOCKS

1. Preprocess

In case of signal processing of a camera with single CCD, before the performance of main processing, it takes the optical black appearing before the real data among CCD data as the reference value and the mean figure of it enables correct alignment of the black in the main processing, and in case of defect found existing in CFA mode, it locates 4 erroneous spots in maximum and processes to replace the errors with two siding data by initial interpolation and then outputs line memory.

2. Line memory

Two built-in 10 bits line memories for 3 line color processing in 2H delay application, enable simultaneous vision of 3 horizontal video lines, and in the processing of luminance signals, 1H delayed signal, the H1D is offered, and in the chroma signal processing, HO2D or the luminance signal process lines interpolated by two siding lines one in front and the other in the back are offered.

The line memory has 1024 depth for safe application to a CCD with 620 pixels, of 16:9 aspect.

For application to gyro sensor based and CCD controlled electronic image stabilizer system, it has the functional capability to hold previous line at the blank signal line.

This is externally controlled by a LHLD signal.

3. Y processor

- LPF

The filter removes recurring pattern noise of single type CCD

- Non-linear characteristics in H aperture application :

In order to reduce back noise caused by the noise of low luminance when H aperture is emphasized, low luminance components are compressed before the aperture.

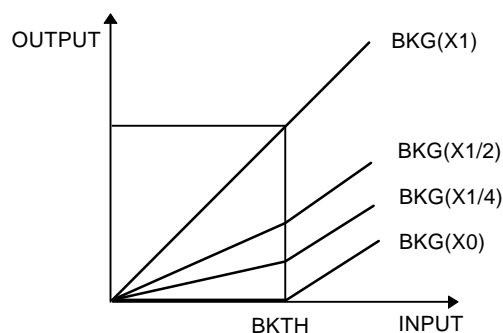

- H_Aperture

Horizontal and vertical outline portions are emphasized.

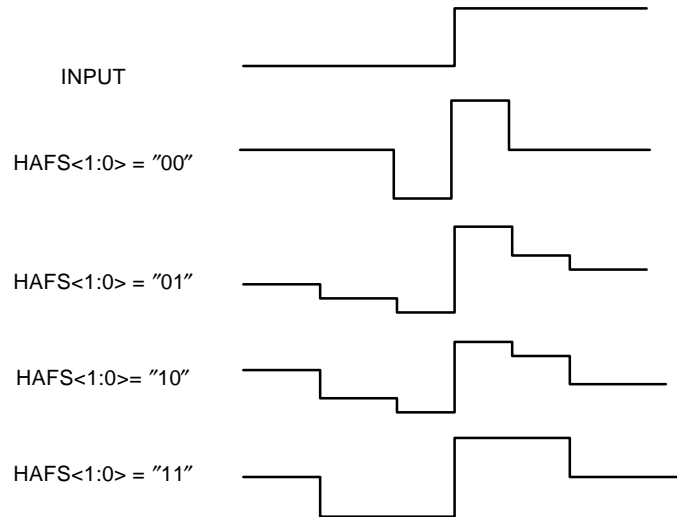

- REGISTER

HAPG : Horizontal Aperture Gain Control
5bits (X0 ~ X0.96875)

VAPG : Vertical Aperture Gain Control
5bits (X0 ~ X1.9375)

APSC : Aperture Slice Level
6bits (0~63)

APCLP : Aperture Clip Level
2bits

00	OFF
01	256
10	128
11	64

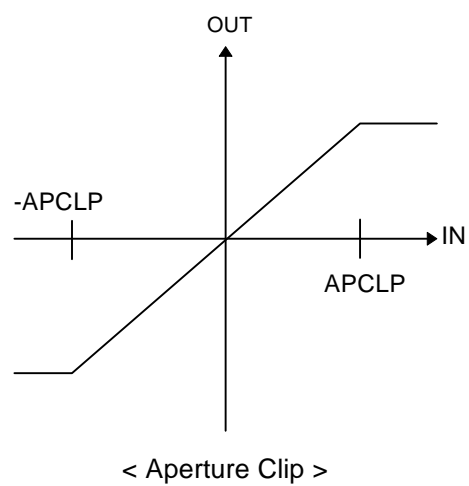
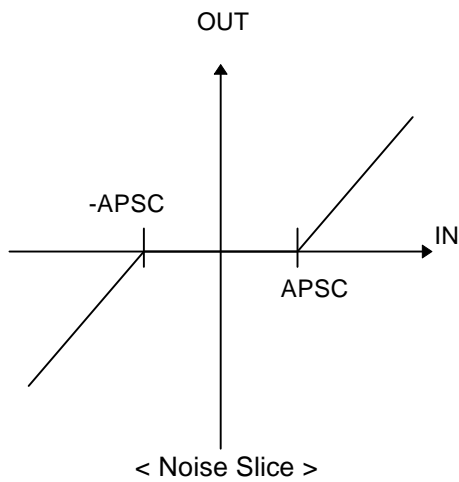

- Gamma and knee

Adopting user defined variable gamma and knee in eight steppiecewise linear method allows the user free adjustment of the coefficient.

4. C-Processor

- S/H and interpolation LPF

With the input of HID and H02D signals from the line memory, C-Processor samples and holds S_1 and S_2 for the generation of RGB chroma signals.

The band width of the signals so generated is limited by LPF.

- RGB matrix

Based on C_r , C_b and Y_C signals being the sum and balance components of S_1 and S_2 , RGB chroma signals are obtainable from the following matrix.

$$\begin{aligned} Y_C &= S_1 + S_2, C_r = S_2 - S_1, C_b = S_1 - S_2 \\ R &= C_r + CCOR \times Y_C \text{ (or G)} \\ G &= Y_C - (C_r + C_b) \\ B &= C_b + CCOB \times G \text{ (or } Y_C) \end{aligned}$$

Register :

CCOR : Matrix coefficient for RED generation 6 bits (0-X0.25)

CCOB : Matrix coefficient for BLU generation 6 bits (0-X0.25)

CMATX :	2bits	RED	BLUE
	00	Y_C	G
	01	G	G
	10	G	Y_C
	11	Y_C	Y_C

- White and black balance control :

Through interfacing with the micom, RB signal level is coordinated with G signal level.

Register :

- * GWB : GREEN WHITE BALANCE CONTROL
8 bits (0~X4)
- * RWB : RED WHITE BALANCE CONTROL
8 bits (0~X8)
- * BWB : BLUE WHITE BALANCE CONTROL
8 bits (0~X8)
- * GBLK : GREEN BLACK BALANCE CONTROL(2'S complement)
8 bits (-128 ~127)
- * RBLK : RED BLACK BALANCE CONTROL(2'S complement)
8 bits (-128 ~127)
- * BBLK : BLUE BLACK BALANCE CONTROL(2'S complement)
8 bits (-128 ~127)

- Gamma correction :

The process is identical to the variable gamma method employed in the process of Y signals.

Register :

CGM1 - CGM8 : C-Gamma Y fraction coefficient
8 bits (0~255)

- Chroma MATRIX

It generates R-Y and B-Y signals of basic color space used as NTSC/PAL broadcast standards.

- HUE and gain control

Micro adjustment can be made to coordinate the balance vector to its complement color vector. Individual adjustment against +, - on the R-Y and B-Y vector space that color regeneration is enhanced.

Register :

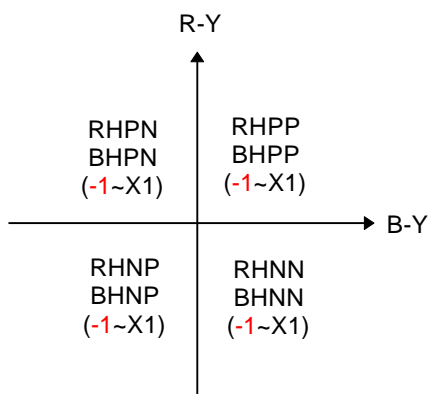

- Chroma suppress

It suppresses false chroma signal by horizontal outline and high luminance signal. Suppress level is adjustable by the mode data.

- Chroma signal interface

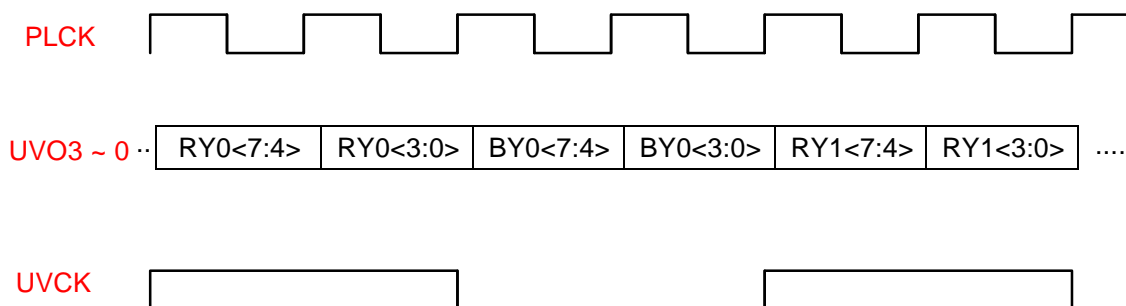

5. NTSC/PAL encoder

- Digital effects

It performs various digital effects and Mosaic, Art Freeze, and Posi/Nega inversion.

Register :

. Art 3 bit 000:normal 001:128 repval* 010:64 rep val* 011:32 rep val*
 100:6 repval* 101:8 rep val* 110:4 rep val* 111:2 rep val*
 (*Repval stands for representative value.)

. Nega 1 bit 0:normal 1:negative

- Fade function

A smooth screen shift is available by Y/C gain control (8bit resolution)

Register :

. Ygain 8bits 0-X1
 . Cgain 8bits 0-X1

- Set-up and white clip

It determines the set-up level that conforms to specific broadcast method (NTSC/PAL) and determines also adequate white clip level.

Register :

. Set-up 5bits 0-32
 . WCLP 8bits 0-256

- BLK/SYNC mix

CBLK/CSYNC are mixed to conform specific broadcast method

- Sampling frequency converter

The chroma signal synchronized to PCLK is converted to 4FSC frequency for chroma modulation.

- Modulation

The chroma data synchronized to 4FSC is put to repeat R-Y, B-Y in 2FSC frequency, and invert in 4FSC frequency and thus modulation of chroma signal is achieved. In this process the level of burst signal applied by the EUSC/EVSC reg, can be controlled and by the adjustment of EUSC/EVSC, color phase can be rotated entirely.

Register :

. EUSC 8bits B-Y burst level
 . EVSC 8bits R-Y burst level

- Delay

The delays developed in the signal processing path of luminance and chroma signals are compensated and other delicate delays resultant from the external applications can also be compensated.

6. OPD Processor

The OPD Processor detects signals for AE/AF1/AF2/AWB and enters the detected signals to the micom through the micom interface. The signals for AF1/AF2 can be detected simultaneously in one field for both of integral and peak values and the detection field can be set freely set by the user. The peak value is, however, obtained by means of finding from a line in each field first and then repeated by lines to fine the peak. The signals for AE/AWB can be detected by means of taking integrated value of entire image or a sectional value of the image area divided in 48 sections.

Register :

* OCMD	8 bits	Mode settings command register
* OA1W1H,OA1W1M,OA1W1L	8 bits * 3	Integrated data of A area for AF1
* OA1W1H,OA1W1M,OA1W1L	8 bits * 3	Integrated data of A area for AF2
* OA1W2H,OA1W2M,OA1W2L	8 bits * 3	Integrated data of B area for AF1
* OA2W2H,OA2W2M,OA2W2L	8 bits * 3	Integrated data of B area for AF2
* OAP1W1H,OAP1W1L	8 bits * 2	Peak data of A area for AF1
* OAP2W1H,OAP2W1L	8 bits * 2	Peak data of A area for AF2
* OAP1W2H,OAP1W2L	8 bits * 2	Peak data of B area for AF1
* OAP2W2H,OAP2W2L	8 bits * 2	Peak data of B area for AF2
* OACCH,OACCM,OACCL	8 bits * 3	Peak data of full area for AE/AWB
* OMDH,OMDL	8 bits * 2	Integrated of small image of sectioned area
* OWM	8 bits	Pixel number of small image of sectioned area
* OWN	8 bits	Line number of small image of sectioned area
* OWSV	8 bits	Vertical start point of area A for AF
* OWSH	8 bits	Horizontal start point of area A for AF
* OADR	6 bits	RAM start address (Write/Read)

- LPF; 6Tap FIR filter (-3db at 2 MHz)
Signal band for input is limited for AE/AF.

- HPF; 3 Order IIR filter (HPF1:200KHZ, HPF2:600KHZ)

The filter suppresses low frequency components to enable detection of only the outline signal selectively for AF1/AF2. Detection of AF1/AF2 is performed simultaneously for each horizontal line that detection of AF1/AF2 signal in any one field is enabled.

The filter 3 order IIR filter is structured a hardware like, but coefficients are devised programmable that the performance character can be adjusted by the user.

Register :

* OPC2A, OPC2B, OPC2C, OPC2D, OPC2E, OPC2F, OPC2G	8bits	AF2 HPF COEFFICIENTS
* OPC1A, OPC1B, OPC1C, OPC1D, OPC1E, OPC1F, OPC1G	8bits	AF1 HPF COEFFICIENTS

- Comparator

It removes chroma signal from the high luminance and low luminance components in R-Y and B-Y signals in order to limit the signal range suitable for input to AWB for the purpose of the signal detections.

Register

* OYH	6bits	High luminance threshold level
* OYL	6bits	Low luminance threshold level
* ORYTH	6bits	R-Y chroma signal threshold level
* ORYTH	6bits	B-Y chroma signal threshold level
* ORBYTH	6bits	(R-Y) + (B-Y) threshold level

7. Timing interface

It generates various clock as required in the inside of IC and performs delay adjust for various video synchronizing signals and also the delay adjustment of final output of video synchronization signal.

8. Micom interface

A parallel interface is employed for transmission of information over various parameters required in the signal processing. And all sorts of commands and coefficients are either processed or set through the port, and reading signal for detection of AE/AF/AWB.(For AE/AF/AWB detection, reading of signals should be completed within VBLK process time.)

For the coefficients of fields, the write timing is enabled from the next field to alleviate the burden of the micom.

In this instance, your attention is invited to the fact that if complete setting of coefficients that should be set initially during the VBLK time is not accomplished, later setting will cause image instability. Primarily, parallel port interface is applicable to NEC series and SAM8 series micom.

9. D/A converter

The device contains two built-in channels of D/A converters for encoded luminance and chroma signals.

KS7306 MICOM REGISTER MAP

ADDR.	DATA								USED	
	D7	D6	D5	D4	D3	D2	D1	D0		
00H	YVBKTH<1:0> (Vertical Black noise THreshold value)		YVBKG<1:0> (Vertical Black noise Gain)		YHBKTH<1:0> (Horizontal Black noise THreshold value)		YHBKG<1:0> (Horizontal Black noise Gain)		LUMA	
	10(2H)		10(2H)		10(2H)		10(2H)			
01H	YHAFS<1:0> (Horizontal Aperture Filter Selection)		YDVCN EGA (DVC mode NEGA effect)	YHAPG<4:0> (Horizontal APerture Gain)						LUMA
	10(2H)		0(0H)	10000 (10H)						
02H	YSEL (Y signal SElect for ODM)	YEGCS (EdGe Color Supress)	YHLCS (High-Light Color Supress)	YVAPG <4:0> (Vertical APerture Gain)						LUMA
	1(1H)	1(1H)	1(1H)	10000 (10H)						
03H	YAPSC <5:0> (APerture Slice Control)						YAPCLP<1:0> (APerture CLIP)		LUMA	
	000000 (00H)						10(2H)			
04H	YHLREF <7:0> (Y HighLight REFERENCE value for colorsupress)								LUMA	
	10000000 (80H)									
05H	YEGREF <7:0> (Y Edge REFERENCE value for colorsupress)								LUMA	
	00010000 (10H)									
06H	YGM1 <7:0> (Y Signal GamMa bending point 1)								LUMA	
	00011100 (1CH)									
07H	YGM2 <7:0> (Y Signal GamMa bending point 2)								LUMA	
	00100111 (27H)									
08H	YGM3 <7:0> (Y Signal GamMa bending point 3)								LUMA	
	00110101 (35H)									
09H	YGM4 <7:0> (Y Signal GamMa bending Point 4)								LUMA	
	01001001 (49H)									
0AH	YGM5 <7:0> (Y Signal GamMa bending Point 5)								LUMA	
	01100100 (64H)									
0BH	YGM6 <7:0> (Y Signal GamMa bending Point 6)								LUMA	
	10001000 (88H)									
0CH	YGM7 <7:0> (Y Signal GamMa bending point 7)								LUMA	
	10111010 (BAH)									
0DH	YGM8 <7:0> (Y Signal GamMa bending point 8)								LUMA	
	11111111 (FFH)									
0EH	YART<2:0> (Y Process ART freeze effect for DVC mode)		YLPFSEL<1:0> (Y process LPF SElection)		YCSLDLY<2:0> (Color Supression coeff. DeLaY adjust)				LUMA	
	000(0H)		00 (0H)		000 (0H)					

ADDR.	DATA								USED
	D7	D6	D5	D4	D3	D2	D1	D0	
20H	CDVCN EGA (C process DVC mode NEGA effect) 0(0H)	CLPFSEL (Cr/Cb/YI Signal LPF Select)			Not Used	CYLS (YI Signal Gen.. Select)	CRMS (Cr Signal Matrix Select)	CBMS (Cb Signal Matrix Select)	CHROMA
21H	CCORB<7:0> → CCOR<7:0> (Color matrix Coeff. of Cr signal)								CHROMA
	01100111 (67H)								
22H	CCORB<7:0> → CCOB<7:0> (Color matrix Coeff. of Cr signal)								CHROMA
	01100111 (67H)								
23H	CWBRB<7:0> → CWBR<7:0> (Color White Balance coeff. of Cr signal)								CHROMA
	00101000 (28H)								
24H	CWBRB<7:0> → CWBB<7:0> (Color White Balance coeff. of Cb signal)								CHROMA
	01000011 (43H)								
25H	CWBG<7:0> (Color White Balance coeff. of G signal)								CHROMA
	00100000 (20H)								
26H	CDSRB<7:0> → CDSR<7:0> (Color Dark Slice coeff. of Cr signal)								CHROMA
	00000000 (00H)								
27H	CDSRB<7:0> → CDSB<7:0> (Color Dark Slice coeff. Of Cb signal)								CHROMA
	00000000 (00H)								
28H	CDSG <7:0> (Color Dark Slice coeff. Of G signal)								CHROMA
	00000000 (00H)								
29H	CGY1 <7:0> (Chroma Signal Gamma bending Point 1)								CHROMA
	00011100 (1CH)								
2AH	CGY2 <7:0> (Chroma Signal Gamma bending Point 2)								CHROMA
	00100111 (27H)								
2BH	CGY3 <7:0> (Chroma Signal Gamma bending Point 3)								CHROMA
	00110101 (35H)								
2CH	CGY4 <7:0> (Chroma Signal Gamma bending Point 4)								CHROMA
	01001001 (49H)								
2DH	CGY5 <7:0> (Chroma Signal Gamma bending Point 5)								CHROMA
	01100100 (64H)								
2EH	CGY6 <7:0> (Chroma Signal Gamma bending Point 6)								CHROMA
	10001000 (88H)								
2FH	CGY7 <7:0> (Chroma Signal Gamma bending Point 7)								CHROMA
	10111010 (BAH)								
30H	CGY8 <7:0> (Chroma Signal Gamma bending Point 8)								CHROMA
	11111111 (FFH)								

ADDR.	DATA								USED
	D7	D6	D5	D4	D3	D2	D1	D0	
31H	CRRGP <7:0> (Cr(R-G) signal Positive gain) 01011001 (59H)								CHROMA
32H	CRRGN <7:0> (Cr(R-G) signal Negative gain) 0101001 (59H)								CHROMA
33H	CRBGP <7:0> (Cr(B-G) signal Positive gain) 11110010 (F2H)								CHROMA
34H	CRBGN <7:0> (Cr(B-G) signal Negative gain) 11110010 (F2H)								CHROMA
35H	CBRGP <7:0> (Cb(R-G) signal Positive gain) 11011001 (D9H)								CHROMA
36H	CBRGN <7:0> (Cb(R-G) signal Negative gain) 11011001 (D9H)								CHROMA
37H	CBBGP <7:0> (Cb(B-G) signal Positive gain) 01110010 (72H)								CHROMA
38H	CBBGN <7:0> (Cb(B-G) signal Negative gain) 01110010 (72H)								CHROMA
39H	CRGP <7:0> (Color difference signal (R-Y) Positive gain) 01000000 (40H)								CHROMA
3AH	CRGN <7:0> (Color difference signal (R-Y) Negative gain) 01000000 (40H)								CHROMA
3BH	CRHP <7:0> (Color difference signal (R-Y) Hue control Positive gain) 00000000 (00H)								CHROMA
3CH	CRHN <7:0> (Color difference signal (R-Y) Hue control Negative gain) 00000000 (00H)								CHROMA
3DH	CBGP <7:0> (Color difference signal (B-Y) Positive gain) 01000000 (40H)								CHROMA
3EH	CBGN <7:0> (Color difference signal (B-Y) Negative gain) 01000000 (40H)								CHROMA
3FH	CBHP <7:0> (Color difference signal (B-Y) Hue control Positive gain) 00000000 (00H)								CHROMA
E0H	CBHP <7:0> (Color difference signal (B-Y) Hue control Negative gain) 00000000 (00H)								CHROMA
40H	OA112 <7:0> (ODM HFP coeff. A11 for AF2) 01101011 (6BH)								OPT_ DETECT
41H	OA212 <7:0> (ODM HPF coeff. A21 for AF2) 01110011 (73H)								OPT_ DETECT

ADDR.	DATA								USED
	D7	D6	D5	D4	D3	D2	D1	D0	
42H	OA222 <7:0> (ODM HPF coeff. A22 for AF2)								OPT_ DETECT
	10010101 (95H)								
43H	OB102 <7:0> (ODM HPF coeff. B10 for AF2)								OPT_ DETECT
	0110101 (75H)								
44H	OB202 <7:0> (ODM HPF coeff. B20 for AF2)								OPT_ DETECT
	01111011 (7BH)								
45H	OB212 <7:0> (ODM HPF coeff. B21 for AF2)								OPT_ DETECT
	10000110 (86H)								
48H	OCMD <7:0> (ODM Command)								OPT_ DETECT
	00000000 (00H)								
49H	OA111 <7:0> (ODM HPF coeff. A11 for AF1)								OPT_ DETECT
	01001010 (4AH)								
4AH	OA211 <7:0> (ODM HPF coeff. A21 for AF1)								OPT_ DETECT
	01010100 (54H)								
4BH	OA221 <7:0> (ODM HPF coeff. A22 for AF1)								OPT_ DETECT
	10110010 (B2H)								
4CH	OB101 <7:0> (ODM HPF coeff. B10 for AF1)								OPT_ DETECT
	01100101 (65H)								
4DH	OB201 <7:0> (ODM HPF coeff. B20 for AF1)								OPT_ DETECT
	01100101 (65H)								
4EH	OB211 <7:0> (ODM HPF coeff. B21 for AF1)								OPT_ DETECT
	10100001 (A1H)								
50H	OW1SH <7:0> (ODM Horizontal Start point of Window1 for AF)								OPT_ DETECT
	01010100 (54H)								
51H	OW1EH <7:0> (ODM Horizontal End point of Window1 for AF)								OPT_ DETECT
	10100100 (A4H)								
52H	OW1SV <7:0> (ODM Vertical Start point of Window1 for AF)								OPT_ DETECT
	00101010 (2AH)								
53H	OW1EV <7:0> (ODM Vertical End point of Window1 for AF)								OPT_ DETECT
	01010010 (52H)								
54H	Not Used	OAETH <5:0> (ODM AE mode THreshold vaiue)						OPT_ DETECT	
		000000 (00H)							
55H	Not Used	OYH_AE <5:0> (ODM Y signal Upper threshold value of AE mode)						OPT_ DETECT	
		111111 (3FH)							
56H	Not Used	OYL_AE <5:0> (ODM Y signal Lower threshold value of AE mode)						OPT_ DETECT	
		000000 (00H)							

ADDR.	DATA								USED
	D7	D6	D5	D4	D3	D2	D1	D0	
57H	Not Used		OYH_AWB<5:0> (ODM Y signal upper threshold value of AWB mode) 111111 (3FH)						OPT_ DETECT
58H	Not Used		OYL_AWB <5:0> (ODM Y signal Lower threshold value of AWB mode) 000000 (00H)						OPT_ DETECT
59H	Not Used			ORYTH <4:0> (ODM R-Y signal THreshold value of AWB mode) 11111 (1FH)					OPT_ DETECT
5AH	Not Used			OBYTH <4:0> (ODM B-Y signal THreshold value of AWB mode) 11111 (1FH)					OPT_ DETECT
5BH	OHPF1E N(ODM HPF1 Enable signal) 0(0H)	OAREA (OCMP AREA) 0(0H)	ORBYTH <5:0> (ODM (R-Y)+(B-Y) signal THreshold value of AWB mode) 001111 (0FH)						OPT_ DETECT
5CH	OW2SH <7:0> (ODM Horizontal Start point of Window2 for AF) 00000100 (04H)								OPT_ DETECT
5DH	OW2EH <7:0> (ODM Horizontal End point of Window2 for AF) 11110010 (F2H)								OPT_ DETECT
5EH	OW2SV<7:0> (ODM Vertical Start point of Window2 for AF) 00000010 (02H)								OPT_ DETECT
5FH	OW2EV <7:0> (ODM VERTICAL End point of Window2 for AF) 01110111 (77H)								OPT_ DETECT
60H	OAWO <23:16> → OA1W1H <7:0> (ODM AF1 accumulation result of Window1) 00000000 (00H)								OPT_ DETECT
61H	OAWO <7:0> → OA2W1L <7:0> (ODM AF2 accumulation result of Window1) 00000000 (00H)								OPT_ DETECT
62H	OAWO <15:8> → OA2W1M <7:0> (ODM AF2 accumulation result of Window1) 00000000 (00H)								OPT_ DETECT
63H	OAWO <23:16> → OA2W1H <7:0> (ODM AF2 accumulation result of Window1) 00000000 (00H)								OPT_ DETECT
64H	OAWO <7:0> → OA1W2L<7:0> (ODM AF1 accumulation result of Window2) 00000000 (00H)								OPT_ DETECT
65H	OAWO <15:8> → OA1W2M <7:0> (ODM AF1 accumulation result of Window2) 00000000 (00H)								OPT_ DETECT
66H	OAWO <23:16>→ OA1W2H <7:0> (ODM AF1 accumulation result of Window2) 00000000 (00H)								OPT_ DETECT
68H	Not Used		OADR <5:0> (ODM loadable RAM ADDRESS) 000000 (00H)						OPT_ DETECT
69H	OMDO <7:0> → OMDL <7:0> (ODM RAM Data) 00000000 (00H)								OPT_ DETECT

ADDR.	DATA								USED
	D7	D6	D5	D4	D3	D2	D1	D0	
6AH	OMDO <15:8> → OMDH <7:0> (ODM RAM Data)								OPT_ DETECT
	00000000 (00H)								
6BH	OMCCO <7:0> → OACCL <7:0> (ODM AE/AWB ACCumulation result)								OPT_ DETECT
	00000000 (00H)								
6CH	OMCCO <15:8> → OACCM<7:0> (ODM AE/AWB ACCumulation result)								OPT_ DETECT
	00000000 (00H)								
6DH	OMCCO <23:16> → OACCL <7:0> (ODM AE/AWB ACCumulation result)								OPT_ DETECT
	00000000 (00H)								
6EH	OAWO <7:0> → OA1W1L <7:0> (ODM AF1 ACCumulation result of Window1)								OPT_ DETECT
	00000000 (00H)								
6FH	OAWO <15:8> → OA1W1M <7:0> (ODM AF1 ACCumulation result of Window1)								OPT_ DETECT
	00000000 (00H)								
70H	Not Used	OWV <5:0> (ODM Vertical subwindow Width of AE/AWB window)						OPT_ DETECT	
		011100 (1CH)							
71H	Not Used	OWH <4:0> (ODM Hor. subwindow Width of AE/AWB window)						OPT_ DETECT	
77H	OAWO <7:0> → OA2W2L <7:0> (ODM AF2 accumulation result of Window2)								OPT_ DETECT
	00000000 (00H)								
78H	OAWO <15:8> → OA2W2M <7:0> (ODM AF2 accumulation result of Window2)								OPT_ DETECT
	00000000 (00H)								
79H	OAWO <23:16> → OA2W2H <7:0> (ODM AF2 accumulation result of Window2)								OPT_ DETECT
	00000000 (00H)								
7AH	OAP1W1 <7:0> (ODM Peak hold for AF1 of Window1)								OPT_ DETECT
	00000000 (00H)								
7BH	OAP2W1 <7:0> (ODM Peak hold for AF2 of Window1)								OPT_ DETECT
	00000000 (00H)								
7CH	OAP1W2 <7:0> (ODM Peak hold for AF1 of Window2)								OPT_ DETECT
	00000000 (00H)								
7DH	OAP2W2 <7:0> (ODM Peak hold for AF2 of Window2)								OPT_ DETECT
	00000000 (00H)								
7EH	OWSV <7:0> (ODM Vertical subwindow Start point of AE/AWB window)								OPT_ DETECT
	00111110 (3EH)								
7FH	OWSH <7:0> (ODM Horizontal subwindow Start point of AE/AWB window)								OPT_ DETECT
	00000110 (06H)								

ADDR.	DATA								USED
	D7	D6	D5	D4	D3	D2	D1	D0	
80H	Not Used			POBSEL (Optical Black data SElection)	PDETECT1 (Defect enable 1)	PDETECT2 (Defect enable 2)	PCORRECT (Defect CORRECTION enable)	PDCLAMP (Digital CLAMP enable)	PRE PROCESS
				0(0H)	0(0H)	0(0H)	0(0H)	0(0H)	
81H	PDEFECT_TH <7:0> (Preprocess DEFECTTHreshold value)								PRE PROCESS
	00000000 (00H)								
82H	Not Used						PHCNT_REF <9:8>		PRE PROCESS
							00(0H)		
83H	PHCNT_REF <7:0> (Preprocess Horizontal CouNT REFERENCE value)								PRE PROCESS
	00000000 (00H)								
84H	PVCNT_REF <7:0> (Preprocess Vertical CouNT REFERENCE value)								PRE PROCESS
	00000000 (00H)								
85H	PHSTART<3:0> (Preprocess defect detection Horizontal START point)				PVSTART<3:0> (Preprocess defect detection Vertical START point)				PRE PROCESS
	0000(0H)				0000(0H)				
86H	PCLP_START<7:0> (Preprocess digital Clamp optical black START point)								PRE PROCESS
	00000000 (00H)								
87H	Not Used						POB_MICOM <9:8>		PRE PROCESS
							00(0H)		
88H	POB_MICOM<7:0> (Preprocess optical black data from MICOM)								PRE PROCESS
	00000000 (00H)								
89H	PSG_ODD_POS<3:0> (Preprocess SG pulse ODD field POSition)				PSG_EVEN_POS<3:0> (Preprocess SG pulse EVEN field POSition)				PRE PROCESS
	0000(0H)				0000(0H)				
90H	PA1 <7:0> (Preprocess defect address 1)								PRE PROCESS
	00000000 (00H)								
91H	PA1 <15:8>								PRE PROCESS
	00000000 (00H)								
92H	Not Used	PB1<2:0>			Not Used	PA1<18:16>			PRE PROCESS
		000(0H)				000(0H)			
93H	PA2 (Preprocess defect address 2)								PRE PROCESS
	00000000 (00H)								
94H	PA2								PRE PROCESS
	00000000 (00H)								

ADDR.	DATA								USED
	D7	D6	D5	D4	D3	D2	D1	D0	
95H	Not Used	PB2<2:0>			Not Used	PA2			PRE PROCESS
		000(0H)				000(0H)			
96H	PA3 (Preprocess defect address 3)								PRE PROCESS
	00000000 (00H)								
97H	PA3								PRE PROCESS
	00000000 (00H)								
98H	Not Used	PB3<2:0>			Not Used	PA3			PRE PROCESS
		000(0H)				000(0H)			
99H	PA4 (Preprocess defect address 4)								PRE PROCESS
	00000000 (00H)								
9AH	PA4								PRE PROCESS
	00000000 (00H)								
9BH	Not Used	PB4<2:0>			Not Used	PA4			PRE PROCESS
		000(0H)				000(0H)			
AOH	ENP (Encoder Nega/Po si effect)	EART <2:0> (Encoder ARTfreeze Effect)			EYDL <3:0> (Encoder Y signal DeLay control selection)				ENCODER
		0(0H)			0000(0H)				
A1H	EYGAIN <7:0> (Encoder Y signal GAIN)								ENCODER
	10110000 (BOH)								
A2H	ECGAIN <7:0> (Encoder Color signal GAIN)								ENCODER
	01001000 (48H)								
A3H	EDZCBLK OFF (Encoder DZ mode CBLK OFF)	Not Used			ESU (Encoder luminance set-up level)				ENCODER
					00000(00H)				
A4H	EWC <7:0> (Encoder White Clip Control)								ENCODER
	11001000 (C8H)								
A5H	EBLK <7:0> (Encoder luminance BLanK Level)								ENCODER
	00111111 (3FH)								
A6H	EUSC <7:0> (Encoder U(B-Y) Signal burst level Control)								ENCODER
	00011111 (1FH)								
A7H	EVSC <7:0> (Encoder V(R-Y) Signal burst level Control)								ENCODER
	00011111 (1FH)								

ADDR.	DATA								USED
	D7	D6	D5	D4	D3	D2	D1	D0	
A8H	EMBCK_SEL (Encoder BM clock SElection)	EDLY_SEL <3:0> (Encoder DeLaY Selection)			EBFDLY <2:0> (Encoder BF Delay Selection)			ENCODER	
	0(0H)	0000 (0H)			00 (0H)				
A9H	Not Used				FSC_CO NT (FSC Control)	FSC2_ CONT (FSC2 Control)	FSC_R N_ SEL (FSC Reset selectio n)	ENCODER	
					0(0H)	0(0H)	0(0H)		
FAH	Not Used				S1 <3:0> (Delay Control Selection)			DLYCO NT	
				0000(0H)					
FBH	Not Used		S2 <5:0> (Delay Control Selection)					DLYCO NT	
		000000(00H)							
FCH	TSTCMD <7:0> (TeST ComManD)							MICOM_ IF	
00000000 (00H)									
FDH	FCM (FCM mode)	Not Used	HSYNCS <2:0> (H SYNC pulse delay Selection)			Not Used			MICOM_ IF
	0 (0H)		000 (0H)						
FEH	LALT-CONT (LALT signal CONTROL)	XCK-CONT (External Clock control for kasan)	Not Used	MPCKSEL (Multi-Media selection)	HSEL (Horizontal selection)	VSEL (Vertical selection)	SCK_ CONT (S-Clock control)	UVCK_ CONT (UV-Clock control)	MICOM_ IF
	0 (0H)	0 (0H)		0 (0H)	0 (0H)	0 (0H)	0 (0H)	0 (0H)	
FFH	SYNCHSH (SYNC wave SHape)	Not Used	C422 (4:2:2 mode)	WIDE (WIDE mode)	OLPFSEL (LPF selection for ODM)	PAL (PAL mode)	HI8 (HIband 8mm mode)	DZ (Digital zoom mode)	MICOM_ IF
	0 (0H)		0 (0H)	0 (0H)	0 (0H)	0 (0H)	0 (0H)	0 (0H)	

1. ADDRESS 00

- 1) YVBKTH <1:0> : Vertical Black noise THreshold value
- DATA <7:6>
- 2) YVBKG <1:0> : Vertical Black noise Gain
- DATA <5:4>
- 3) YHBKTH <1:0> : Horizontal Black noise THreshold value
- DATA <3:2>
- 4) YHBKG <1:0> : Horizontal Black noise Gain
- DATA <1:0>

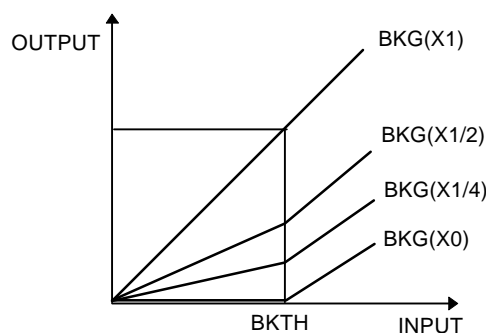

2. ADDRESS 01

- 1) YHAFS <1:0> : Horizontal Aperture Filter Selection
- DATA <7:6>
- 2) YDVCNEGA: Y process DVC mode NECA effect
- DATA <5>

YDVCNEGA = "0"	Normal operation(POSI)
YDVCNEGA = "1"	Level conversion(NEGA)

- 3) YHAPG <4:0> : Horizontal APerture Gain
- DATA <4:0>
- RANGE : x0 ~ x0.96875
- FORMAT : 0.xxxxx

3. ADDRESS 02

- 1) YSEL : Y signal SElection for OPT_DETECT
- DATA <7>
- OYSEL = "0" : Line Memory output is input to OPT-DEFECT Block that passed LPF.
- OYSEL = "1" : Line Memory output is input directly to OPE-DEFECT Block.
- 2) YEGCS : EdGe Color Supress
- DATA <6>
- 3) YHILCS : HighLight Color Supress
- DATA <5>

EGCS HLCS	SELECT
00	"000"
01	HighLight Coeff.
10	Edge Coeff.
11	IF(HighLight Coeff. > Edge Coeff. ⇒ HighLight Coeff. ELSE ⇒ Edge Coeff.

- 4) YVAPG <4:0> : Vertical APerture Gain
 - DATA <4:0>
 - RANGE : X0 ~ X1.9375
 - FORMAT : X.XXXX

4. ADDRESS 03

- 1) YAPSC <5:0> : APerture Slice Control
 - DATA <7:2>
 - RANGE : 0 ~ 31
- 2) YAPCLP <1:0> : APerture CLiP
 - DATA <1:0>

5. ADDRESS 04

- 1) YHLREF <7:0> : Y HighLight REFerence for Color Supress
 - DATA <7:0>
 - IF (Y <YHLREF) ⇒ HighLight Coeff. = "000"
 - ELSE ⇒ HighLight Coeff. = "000" ~ "111"

6. ADDRESS 05

- 1) YEGREF <7:0> : Y EdGe REFerence for color Supress
 - DATA <7:0>
 - IF (Y <YEGREF) ⇒ Edge Coeff. = "000"
 - ELSE ⇒ Edge Coeff. = "000" ~ "111"

7. ADDRESS 06

- 1) YGM1 <7:0> : Y signal GamMa coeff.1
 - DATA <7:0>

8. ADDRESS 07

- 1) GM2 <7:0> : Y signal GamMa coeff.2
 - DATA <7:0>

9. ADDRESS 08

- 1) YGM3 <7:0> : Y signal GamMa coeff.3
- DATA <7:0>

10. ADDRESS 09

- 1) YGM4 <7:0> : Y signal GamMa coeff.4
- DATA <7:0>

11. ADDRESS 0A

- 1) YGM5 <7:0> : Y signal GamMa coeff.5
- DATA <7:0>

12. ADDRESS 0B

- 1) YGM6 <7:0> : Y signal GamMa coeff.6
- DATA <7:0>

13. ADDRESS 0C

- 1) YGM7 <7:0> : Y signal GamMa coeff.7
- DATA <7:0>

14. ADDRESS 0D

- 1) YGM8 <7:0> : Y signal GamMa coeff.8
- DATA <7:0>

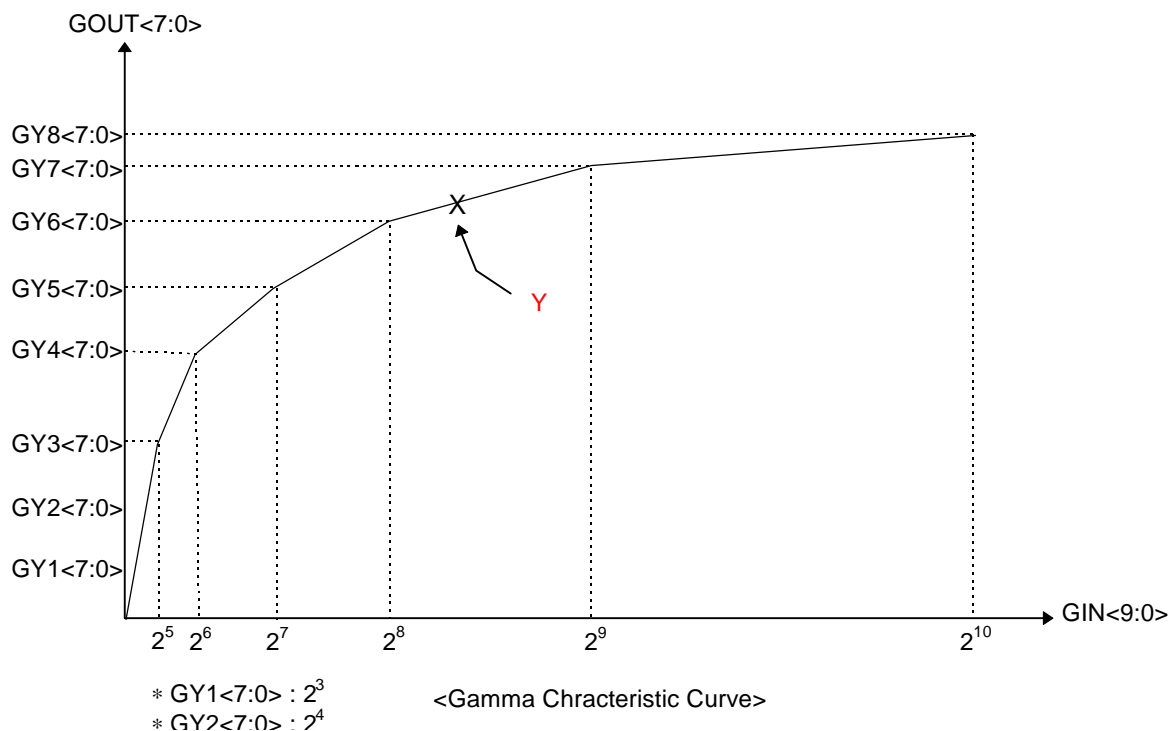

15. ADDRESS 0E

- 1) YART<2:0>: Y signal ART freeze effect for DVC mode
 - DATA <7:5>

YART<2><1><0>	OPERATION	YART<2><1><0>	OPERATION
0 0 0	256 Level	1 0 0	16 Level
0 0 1	128 Level	1 0 1	8 Level
0 1 0	64 Level	1 1 0	4 Level
0 1 1	32 Level	1 1 1	2 Level

- 2) YLPFSEL <1:0> : Y signal LPFSElection
 - DATA <4:3>

- 3) YCSDLY <2:0> : Color Supression coeff. DeLaY adjust
 - DATA <2:0>

YCSDLY<2><1><0>	DELAY	YCSDLY<2><1><0>	DELAY
0 0 0	0 Delays	1 0 0	-4 Delays
0 0 1	+1 Delays	1 0 1	-3 Delays
0 1 0	+2 Delays	1 1 0	-2 Delays
0 1 1	+3 Delays	1 1 1	-1 Delays

16. ADDRESS 20

- 1) CDVCNEGA: C process DVC mode NEGA effect
 - DATA <7>

CDVCNEGA = "0"	Normal Operation (POSI)
CDVCNEGA = "1"	Level Conversion (NEGA)

- 2) CLPFSEL <2:0> : Cr/Cb/YI signal LPF SElection
 - DATA <6:4>

- 3) CYLS : Color YL signal Selection
 - DATA <2>

CYLS = "0"	(S1+S2)/2 of CCD 1H Delay Output
CYLS = "1"	(S1+S2)/2 of CCD of 1H Delay Output + (S1+S2)/2 of CCD of 02H Delay Output

- 4) CRMS : CR signal Matrix Selection
- DATA <1>

- 5) CBMS : CB signal Matrix Selection
- DATA <0>

CSCK	CRMS	CBMS	Matrix Section
0	-	0/1	CRMS
1	0/1	-	CRMS

Matrix Section	OUT-PUT
0	YL
1	YL-(CR-CB)

17. ADDRESS 21

- 1) CCORB <7:0> (CCOR<7:0>) : Color matrixCoeff. of CR signal
- DATA <7:0>
- RANGE : $0 \leq \text{CCOR} < 0.5$
- FORMAT : 0.XXXXXXXXX

18. ADDRESS 22

- 1) CCORB <7:0> (CCOR<7:0>) : Color matrixCoeff. of CB signal
- DATA <7:0>
- RANGE : $0 \leq \text{CCOR} < 0.5$
- FORMAT : 0.XXXXXXXXX
- TIMING : SCK = "0"

19. ADDRESS 23

- 1) CWBRB <7:0> (CWBR<7:0>) : Color White BalanceCoeff. of CR signal
- DATA <7:0>
- RANGE : $0 \leq \text{CWBR} < 8$
- FORMAT : XXX.XXXXX

20. ADDRESS 24

- 1) CWBRB <7:0> (CWBR<7:0>) : Color White BalanceCoeff. of CB signal
- DATA <7:0>
- RANGE : $0 \leq \text{CWBR} < 8$
- FORMAT : XXX.XXXXX

21. ADDRESS 25

- 1) CWBG <7:0> : Color White Balance Coeff. of G signal
- DATA <7:0>
- RANGE : $0 \leq \text{CWBG} < 4$
- FORMAT : XX.XXXXX

22. ADDRESS 26

- 1) CDSRB <7:0> (CDSR<7:0>) : Color Dark Slicecoeff. of CR signal
 - DATA <7:0>
 - RANGE : $-128 \leq \text{CDSR} \leq 127$

23. ADDRESS 27

- 1) CDSG <7:0> (CDSB<7:0>) : Color Dark Slicecoeff. of CB signal
 - DATA <7:0>
 - RANGE : $-128 \leq \text{CDSB} \leq 127$

24. ADDRESS 28

- 1) CDSG <7:0> : Color Dark Slice coeff. of G signal
 - DATA <7:0>
 - RANGE : $-128 \leq \text{CDSG} \leq 127$

25. ADDRESS 29

- 1) CGY1 <7:0> : Color signal Gamma coeff.1
 - DATA <7:0>

26. ADDRESS 2A

- 1) CGY2 <7:0> : Color signal Gamma coeff.2
 - DATA <7:0>

27. ADDRESS 2B

- 1) CGY3 <7:0> : Color signal Gamma coeff.3
 - DATA <7:0>

28. ADDRESS 2C

- 1) CGY4 <7:0> : Color signal Gamma coeff.4
 - DATA <7:0>

29. ADDRESS 2D

- 1) CGY5 <7:0> : Color signal Gamma coeff.5
 - DATA <7:0>

30. ADDRESS 2E

- 1) CGY6 <7:0> : Color signal Gamma coeff.6
 - DATA <7:0>

31. ADDRESS 2F

- 1) CGY7 <7:0> : Color signal Gamma coeff.7
- DATA <7:0>

32. ADDRESS 30

- 1) CGY8 <7:0> : Color signal Gamma coeff.8
- DATA <7:0>

* Characteristics is the same that LUMINANCE.

33. ADDRESS 31

- 1) CRRGP <7:0> : CR(R-G) signal Positive Gain
- DATA <7:0>
- RANGE : 00H ~ FFH (-1X ~ 1X, 2 'S complement)

34. ADDRESS 32

- 1) CRRGN <7:0> : CR(R-G) signal Negative Gain
- DATA <7:0>
- RANGE : 00H ~ FFH (-1X ~ 1X, 2 'S complement)

35. ADDRESS 33

- 1) CRBGP <7:0> : CR(B-G) signal Positive Gain
- DATA <7:0>
- RANGE : 00H ~ FFH (-1X ~ 1X, 2 'S complement)

36. ADDRESS 34

- 1) CRBGN <7:0> : CR(B-G) signal Negative Gain
- DATA <7:0>
- RANGE : 00H ~ FFH (-1X ~ 1X, 2 'S complement)

37. ADDRESS 35

- 1) CBRGP <7:0> : CB(R-G) signal Positive Gain
- DATA <7:0>
- RANGE : 00H ~ FFH (-1X ~ 1X, 2 'S complement)

38. ADDRESS 36

- 1) CBRGN <7:0> : CB(B-G) signal Negative Gain
- DATA <7:0>
- RANGE : 00H ~ FFH (-1X ~ 1X, 2 'S complement)

39. ADDRESS 37

- 1) CBBGP <7:0> : CB(B-G) signal Positive Gain
 - DATA <7:0>
 - RANGE : 00H ~ FFH (-1X ~ 1X), 2 'S complement

40. ADDRESS 38

- 1) CBRGN <7:0> : CB(B-G) signal Negative Gain
 - DATA <7:0>
 - RANGE : 00H ~ FFH (-1X ~ 1X), 2 'S complement

41. ADDRESS 39

- 1) CRGP <7:0> : Color difference signal (R-Y) Positive Gain
 - DATA <7:0>
 - RANGE : 00H ~ 7FH (0X ~ 2X)

42. ADDRESS 3A

- 1) CRGN <7:0> : Color difference signal (R-Y) Negative Gain
 - DATA <7:0>
 - RANGE : 00H ~ 7FH (0X ~ 2X)

43. ADDRESS 3B

- 1) CRHP <7:0> : Color difference signal (R-Y) Hue Control Positive Gain
 - DATA <7:0>
 - RANGE : 00H ~ 7FH (-1X ~ 1X), 2 'S complement

44. ADDRESS 3C

- 1) CRHN <7:0> : Color difference signal (R-Y) Hue Control Negative Gain
 - DATA <7:0>
 - RANGE : 00H ~ 7FH (-1X ~ 1X), 2 'S complement

45. ADDRESS 3D

- 1) CBGP <7:0> : Color difference signal (B-Y) Positive Gain
 - DATA <7:0>
 - RANGE : 00H ~ 7FH (0X ~ 2X)

46. ADDRESS 3E

- 1) CBGN <7:0> : Color difference signal (B-Y) Negative Gain
 - DATA <7:0>
 - RANGE : 00H ~ 7FH (0X ~ 2X)

47. ADDRESS 3F

- 1) CBHP <7:0> : Color difference signal (B-Y) Hue Control Positive Gain
 - DATA <7:0>
 - RANGE : 00H ~ 7FH (-1X ~ 1X), 2 'S complement

48. ADDRESS 40

- 1) OA112 <7:0> : OPT_DETECT HPFcoeff. A11 for AF2
 - DATA <7:0>
 - NORMAL or HI8 mode : 0.8359375 (6BH)
 - DIS mode : 0.8046875 (67H)

49. ADDRESS 41

- 1) OA212 <7:0> : OPT_DETECT HPFcoeff. A21 for AF2
 - DATA <7:0>
 - NORMAL or HI8 mode : 0.8984375 (73H)
 - DIS mode : 0.8750000 (70H)

50. ADDRESS 42

- 1) OA222 <7:0> : OPT_DETECT HPFcoeff. A22 for AF2
 - DATA <7:0>
 - NORMAL or HI8 mode : - 0.8359375 (95H)
 - DIS mode : - 0.8125000 (98H)

51. ADDRESS 43

- 1) OB102 <7:0> : OPT_DETECT HPFcoeff. B10 for AF2
 - DATA <7:0>
 - NORMAL or HI8 mode : 0.9140625 (75H)
 - DIS mode : 0.9062500 (74H)

52. ADDRESS 44

- 1) OB202 <7:0> : OPT_DETECT HPFcoeff. B20 for AF2
 - DATA <7:0>
 - NORMAL or HI8 mode : 0.9609375 (7BH)
 - DIS mode : 0.9453125 (79H)

53. ADDRESS 45

- 1) OB212 <7:0> : OPT_DETECT HPFcoeff. B21 for AF2
 - DATA <7:0>
 - NORMAL or HI8 mode : - 0.9531250 (86H)
 - DIS mode : - 0.9375000 (88H)

54. ADDRESS 48

- 1) OCMD<6:0> : OPT_DETECTComManD
- DATA <7:0>

OCMD<7><6><5><4><3><2><1><0>	MODE
X X X X X X 0 0	Select R-Y Signal for AWB Mode
X X X X X X 0 1	Select B-Y Signal for AWB Mode
X X X X X X 1 0	Select AE Mode
X X X X X X 1 1	Select AE Mode
X X X X X 0 X X	Select RAM WRITE Mode
X X X X X 1 X X	Select RAM READ Mode
X X X X 0 X X X	Select High Pass Filtering Mode
X X X X 1 X X X	Select High Pass Filtering SKIP Mode
X X X 0 X X X X	Select AF Window Pulse Disable
X X X 1 X X X X	Select AF Window Pulse Enable
X 1 1 X X X X X	Select Window Counter Output for Test
0 X X X X X X X	Select AF Window 1 Pulse
1 X X X X X X X	Select AF Window 2 Pulse

55. ADDRESS 49

- 1) OA111 <7:0> : OPT_DETECT HPFcoeff. A11 for AF1
- DATA <7:0>
- NORMAL or HI8 mode : 0.5781502 (4AH)
- DIS mode : 0.5156250 (42H)

56. ADDRESS 4A

- 1) OA211 <7:0> : OPT_DETECT HPFcoeff. A21 for AF1
- DATA <7:0>
- NORMAL or HI8 mode : 0.6562500 (54H)
- DIS mode : 0.5781250 (4AH)

57. ADDRESS 4B

- 1) OA221 <7:0> : OPT_DETECT HPFcoeff. A22 for AF1
- DATA <7:0>
- NORMAL or HI8 mode : - 0.6093750 (B2H)
- DIS mode : - 0.5652500 (B8H)

58. ADDRESS 4C

- 1) OB101 <7:0> : OPT_DETECT HPFcoeff. B10 for AF1
 - DATA <7:0>
 - NORMAL or HI8 mode : 0.7890625 (65H)
 - DIS mode : 0.7578150 (61H)

59. ADDRESS 4D

- 1) OB201 <7:0> : OPT_DETECT HPFcoeff. B20 for AF1
 - DATA <7:0>
 - NORMAL or HI8 mode : 0.7890625 (65H)
 - DIS mode : 0.7421875 (5FH)

60. ADDRESS 4E

- 1) OB211 <7:0> : OPT_DETECT HPFcoeff. B21 for AF1
 - DATA <7:0>
 - NORMAL or HI8 mode : - 0.7421875 (A1H)
 - DIS mode : - 0.6796875 (A9H)

61. ADDRESS 50

- 1) OW1SH <7:0> : OPT_DETECT Horizontal Start Point of Window 1 for AF
 - DATA <7:0>
 - RANGE : $OW1SH \geq OW2SH$

62. ADDRESS 51

- 1) OW1SH <7:0> : OPT_DETECT Horizontal End Point of Window 1 for AF
 - DATA <7:0>
 - RANGE : $OW1SH \leq OW2SH$

63. ADDRESS 52

- 1) OW1SV <7:0> : OPT_DETECT Vertical Start Point of Window 1 for AF
 - DATA <7:0>
 - RANGE : $OW1SV \geq OW2SV$

64. ADDRESS 53

- 1) OW1SV <7:0> : OPT_DETECT Vertical End Point of Window 1 for AF
 - DATA <7:0>
 - RANGE : $OW1EV \leq OW2EV$

65. ADDRESS 54

- 1) OAETH <5:0> : OPT_DETECT AE modeTHreshold value
 - DATA <5:0>
 - IF (Y-signal > OAETH) \Rightarrow Output "1"
 - ELSE \Rightarrow Output "0"

66. ADDRESS 55

- 1) OYH_AE <5:0> : OPT_DETECT Y signal Upper Threshold value of AE mode
- DATA <7:0>

67. ADDRESS 56

- 1) OYL_AE <5:0> : OPT_DETECT Y signal Lower Threshold value of AE mode
- DATA <7:0>
- OYL_AE < Y < OYH_AE

68. ADDRESS 57

- 1) OYH_AWB <5:0> : OPT_DETECT Y signal Upper Threshold value of AWB mode
- DATA <5:0>

69. ADDRESS 58

- 1) OYL_AWB <5:0> : OPT_DETECT Y signal Lower Threshold value of AWB mode
- DATA <5:0>

70. ADDRESS 59

- 1) ORYTH <4:0> : OPT_DETECT R-Y signal Threshold value of AWB mode
- DATA <4:0>

71. ADDRESS 5A

- 1) OBYTH <4:0> : OPT_DETECT B-Y signal Threshold value of AWB mode
- DATA <4:0>

72. ADDRESS 5B

- 1) OHPF1EN: OPT_DETECT HPF1 Enable
- DATA <7>
- OHPF1EN = "0" : Enable
OHPF1EN = "1" : Disable
- 2) OAREA : OPT_DETECT AWB Area select
- DATA <7>
- OAREA = "0" : Narrow Area
OAREA = "1" : Full Area
- 3) ORBYTH <5:0> : OPT_DETECT (R-Y) + (B-Y) signal Threshold value of AWB mode
- DATA <5:0>

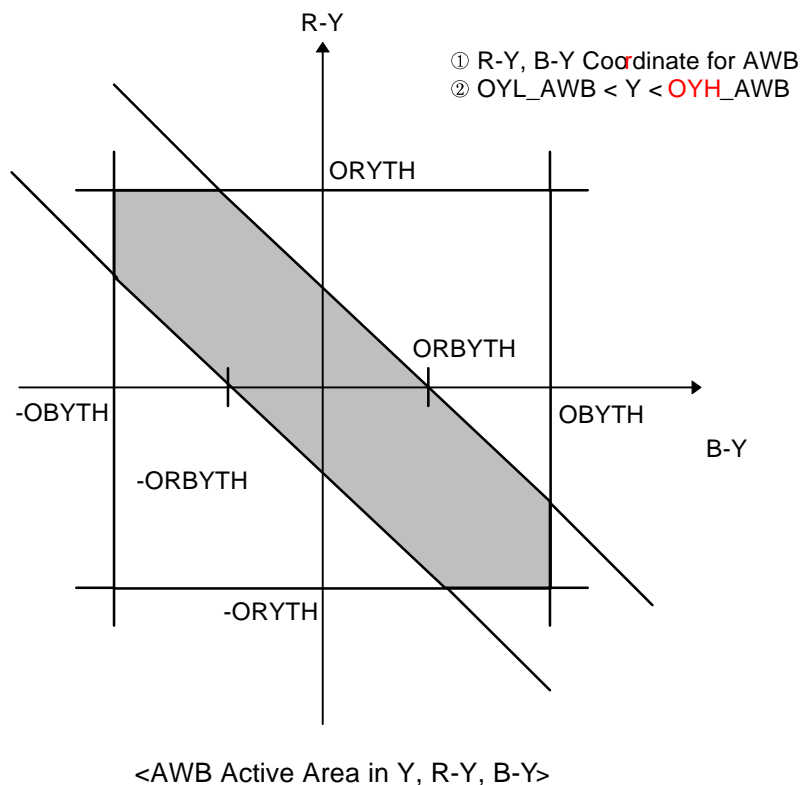
**73. ADDRESS 5C**

- 1) OW2SH <7:0> : OPT_DETECT Horizontal Start point Window2 for AF
 - DATA <7:0>
 - RANGE : $3 \leq \text{OW2SH} \leq 251$

74. ADDRESS 5D

- 1) OW2EH <7:0> : OPT_DETECT Horizontal End point Window2 for AF
 - DATA <7:0>
 - RANGE : $3 \leq \text{OW2EH} \leq 255$

75. ADDRESS 5E

- 1) OW2SV <7:0> : OPT_DETECT Vertical Start point Window2 for AF
 - DATA <7:0>
 - RANGE : $2 \leq \text{OW2SV} \leq 121$

76. ADDRESS 5E

- 1) OW2EV <7:0> : OPT_DETECT Vertical End point Window2 for AF
 - DATA <7:0>
 - RANGE : $3 \leq \text{OW2EV} \leq 122$

77. ADDRESS 60

- 1) OAWO <23:16> : (OA1W1H<7:0>) : OPT_DETECT AF1 accumulation result of Window1
- DATA <7:0>

78. ADDRESS 61

- 1) OAWO <7:0> : (OA2W1L<7:0>) : OPT_DETECT AF2 accumulation result of Window1
- DATA <7:0>

79. ADDRESS 62

- 1) OAWO <15:8> : (OA2W1M<7:0>) : OPT_DETECT AF2 accumulation result of Window1
- DATA <7:0>

80. ADDRESS 63

- 1) OAWO <23:16> : (OA2W1H<7:0>) : OPT_DETECT AF2 accumulation result of Window1
- DATA <7:0>

81. ADDRESS 64

- 1) OAWO <7:0> : (OA1W2L<7:0>) : OPT_DETECT AF1 accumulation result of Window2
- DATA <7:0>

82. ADDRESS 65

- 1) OAWO <15:8> : (OA1W2M<7:0>) : OPT_DETECT AF1 accumulation result of Window2
- DATA <7:0>

83. ADDRESS 66

- 1) OAWO <23:16> : (OA1W2H<7:0>) : OPT_DETECT AF1 accumulation result of Window2
- DATA <7:0>

84. ADDRESS 68

- 1) OADR <5:0> : OPT_DETECTloadable RAM Address
- DATA <5:0>
- RANGE : 0 ~ 63

85. ADDRESS 69

- 1) OMDO <7:0> (OMDL<7:0>) : OPT_DETECT RAM Data
- DATA <7:0>

86. ADDRESS 6A

- 1) OMDO <15:8> (OMDH<7:0>) : OPT_DETECT RAM Data
- DATA <7:0>

87. ADDRESS 6B

- 1) OACCO <7:0> (OACCL<7:0>) : OPT_DETECT AE/AWB Accumulation result
- DATA <7:0>

88. ADDRESS 6C

- 1) OACCO <15:8> (OACCM<7:0>) : OPT_DETECT AE/AWB Accumulation result
- DATA <7:0>

89. ADDRESS 6D

- 1) OACCO <23:16> (OACCH<7:0>) : OPT_DETECT AE/AWB Accumulation result
- DATA <7:0>

90. ADDRESS 6E

- 1) OAWO <7:0> (OA1W1L<7:0>) : OPT_DETECT AF1 Accumulation result of Window1
- DATA <7:0>

91. ADDRESS 6F

- 1) OAWO <15:8> (OA1W1M<7:0>) : OPT_DETECT AF1 Accumulation result of Window1
- DATA <7:0>

92. ADDRESS 70

- 1) OWV <5:0> : OPT_DETECT VerticalSubwindow Width of AE/AWB Window
- DATA <5:0>
- RANGE : $3 \leq OWV \leq 40$

93. ADDRESS 71

- 1) OWH <4:0> : OPT_DETECT HorizontalSubwindow Width of AE/AWB Window
- DATA <4:0>
- RANGE : $3 \leq OWH \leq 31$
- Real Point

94. ADDRESS 77

- 1) OAWO <7:0> (OA2W2L<7:0>) : OPT_DETECT AF2 Accumulation result of Window2
- DATA <7:0>

95. ADDRESS 78

- 1) OAWO <15:8> (OA2W2M<7:0>) : OPT_DETECT AF2 Accumulation result of Window2
- DATA <7:0>

96. ADDRESS 79

- 1) OAWO <23:16> (OA2W2H<7:0>) : OPT_DETECT AF2 Accumulation result of Window2
- DATA <7:0>

97. ADDRESS 7A

- 1) OAP1W1 <7:0> : OPT_DETECT Peak hold result for AF1 of Window1
- DATA <7:0>

98. ADDRESS 7B

- 1) OAP2W1 <7:0> : OPT_DETECT Peak hold result for AF2 of Window1
- DATA <7:0>

99. ADDRESS 7C

- 1) OAP1W2 <7:0> : OPT_DETECT Peak hold result for AF1 of Window2
- DATA <7:0>

100. ADDRESS 7D

- 1) OAP2W2 <7:0> : OPT_DETECT Peak hold result for AF2 of Window2
- DATA <7:0>

101. ADDRESS 7E

- 1) OWSV <7:0> : OPT_DETECT VerticalSubwindow Start point of AE/AWB Window
- DATA <7:0>
- RANGE : $21 \leq \text{OWSV} \leq 228$

102. ADDRESS 7F

- 1) OWSH <7:0> : OPT_DETECT HorizontalSubwindow Start point of AE/AWB Window
- DATA <7:0>
- RANGE : $3 \leq \text{OWSVH} \leq 231$

103. ADDRESS 80

- 1) POBSEL : PREPROCESS Optical Black Selection
- DATA <4>
- POBSEL = "0" : Select CCD Optical Black data
POBSEL = "1" : Select MICOM data
- 2) PDEFECT1 : PREPROCESS DEFECT enable signal
- DATA <3>
- PDEFECT = "0" : Select Defect disable
PDEFECT = "1" : Select Defect enable
- 3) PDEFECT2 : PREPROCESS DEFECT enable signal
- DATA <2>
- PDEFECT = "0" : Select Defect disable
PDEFECT = "1" : Select Defect enable
- 4) PCORRECT : PREPROCESS defect Correction enable signal
- DATA <1>
PCORRECT = "0" : Select Defect Correction disable
PCORRECT = "1" : Select Defect Correction enable
- 5) PDCLAMP : PREPROCESS Digital CLAMP enable signal
- DATA <0>
PDCLAMP = "0" : Select Digital Clamp disable
PDCLAMP = "1" : Select Digital Clamp enable

104. ADDRESS 81

- 1) PDEFECT_TH <7:0> : PREPROCESS DEFECTTHreshold value
- DATA <7:0>

105. ADDRESS 82

- 1) PHCNT_REF <9:8> : PREPROCESS HorizontalCouNT REFERENCE value
- DATA <1:0>

106. ADDRESS 83

- 1) PHCNT_REF <7:0> : PREPROCESS HorizontalCouNT REFERENCE value
- DATA <7:0>

107. ADDRESS 84

- 1) PVCNT_REF <7:0> : PREPROCESS VerticalCouNT REFERENCE value
- DATA <7:0>

108. ADDRESS 85

- 1) PHSTART <3:0> : PREPROCESS Defect Correction Horizontal START point
- DATA <7:4>
- 2) PVSTART <3:0> : PREPROCESS Defect CorrectionVertical START point
- DATA <3:0>

109. ADDRESS 86

- 1) PCLP_START <7:0> : PREPROCESS Digital Clamp optical black start point
- DATA <7:0>

110. ADDRESS 87

- 1) POB_MICOM <9:8> : PREPROCESS Digital Clamp optical black data from MICOM
- DATA <1:0>

111. ADDRESS 88

- 1) POB_MICOM <7:0> : PREPROCESS Digital Clamp optical black data from MICOM
- DATA <7:0>

112. ADDRESS 89

- 1) **PSG_POS1** <3:0> : PREPROCESS SG pulse ODD fieldPOSITION
- DATA <7:4>
- 2) **PSG_POS2** <3:0> : PREPROCESS SG pulse EVEN fieldPOSITION
- DATA <3:0>

113. ADDRESS 90

- 1) PA1 <7:0> : PREPROCESS Defect Vertical & Horizontal Address 1 of first field
- DATA <7:0>

114. ADDRESS 91

- 1) PA1 <15:8> : PREPROCESS Defect Vertical & Horizontal Address 1 of first field
- DATA <7:0>

115. ADDRESS 92

- 1) PA1 <18:16> : PREPROCESS Defect Vertical & Horizontal Address 1 of first field
- DATA <2:0>
- 2) PA1 <2:0> : PREPROCESS Defect Vertical & Horizontal Address 1 of second field
- DATA <6:4>

116. ADDRESS 93

- 1) PA2 <7:0> : PREPROCESS Defect Vertical & Horizontal Address 2 of first field
- DATA <7:0>

117. ADDRESS 94

- 1) PA2 <15:8> : PREPROCESS Defect Vertical & Horizontal Address 2 of first field
- DATA <7:0>

118. ADDRESS 95

- 1) PA2 <18:16> : PREPROCESS Defect Vertical & Horizontal Address 2 of first field
- DATA <2:0>
- 1) PA2 <2:0> : PREPROCESS Defect Vertical & Horizontal Address 2 of second field
- DATA <6:4>

119. ADDRESS 96

- 1) PA3 <7:0> : PREPROCESS Defect Vertical & Horizontal Address 3 of first field
- DATA <7:0>

120. ADDRESS 97

- 1) PA3 <15:8> : PREPROCESS Defect Vertical & Horizontal Address 3 of first field
- DATA <7:0>

121. ADDRESS 98

- 1) PA3 <18:16> : PREPROCESS Defect Vertical & Horizontal Address 3 of first field
- DATA <2:0>
- 2) PB3 <2:0> : PREPROCESS Defect Vertical & Horizontal Address 3 of second field
- DATA <6:4>

122. ADDRESS 99

- 1) PA4 <7:0> : PREPROCESS Defect Vertical & Horizontal Address 4 of first field
- DATA <7:0>

123. ADDRESS 9A

- 1) PA4 <15:8> : PREPROCESS Defect Vertical & Horizontal Address 4 of first field
- DATA <7:0>

124. ADDRESS 9B

- 1) PA4 <18:16> : PREPROCESS Defect Vertical & Horizontal Address 4 of first field
- DATA <2:0>
- 2) PB4 <2:0> : PREPROCESS Defect Vertical & Horizontal Address 4 of second field
- DATA <6:4>

125. ADDRESS A0

- 1) ENP : Encoding Nega/Posi effect
- DATA <7>

ENP	OPERATION
0	Normal Operation (POSI)
1	Level Conversion (NEGA) ⇒ Referred White Clip Level

- 2) EART <2:0> : EncoderARTfereeze effect
- DATA <6:4>

EART <2><1><0>	OPERATION
0 0 0	256 Level
0 0 1	128 Level
0 1 0	64 Level
0 1 1	32 Level
1 0 0	16 Level
1 0 1	8 Level
1 1 0	4 Level
1 1 1	2 Level

- 3) EYDL <3:0> : Encoder Y signal Delay control selection
 - DATA <3:0>

EART <3><2><1><0>	DELAY	EART <3><2><1><0>	DELAY
0 0 0 0	0 Delays	1 0 0 0	-5 Delays
0 0 0 1	+1 Delays	1 0 0 1	-5 Delays
0 0 1 0	+2 Delays	1 0 1 0	-5 Delays
0 0 1 1	+3 Delays	1 0 1 1	-5 Delays
0 1 0 0	+4 Delays	1 1 0 0	-4 Delays
0 1 0 1	+5 Delays	1 1 0 1	-3 Delays
0 1 1 0	+6 Delays	1 1 1 0	-2 Delays
0 1 1 1	+7 Delays	1 1 1 1	-1 Delays

126. ADDRESS A1

- 1) EYGAIN <7:0> : Encoder Y signal GAIN
 - DATA <7:0>
 - RANGE : 0X ~ 1X
 - FORMAT : 0.XXXXXXXXXX

127. ADDRESS A2

- 1) ECGAIN <7:0> : Encoder Color signal GAIN
 - DATA <7:0>
 - RANGE : 0X ~ 1X
 - FORMAT : 0.XXXXXXXXXX

128. ADDRESS A3

- 1) EDZCBLKOFF: Encoder digital zoom mode CBLK OFF
 - DATA <7>

EDZCBLKOFF = "0"	ON
EDZCBLKOFF = "1"	OFF

- 2) ECIFI : Encoder EC_IF block input selection for test
 - DATA <6>
- 3) ECIFI : Encoder EC_IF block input selection for test
 - DATA <5>
- 4) ESU <4:0>: Encoderlumanance signal Set-up level
 - DATA <4:0>

129. ADDRESS A4

- 1) EWC <7:0> : Encoder White Clip Control
 - DATA <7:0>

130. ADDRESS A5

- 1) EBLK <7:0> : Encoder lumanance signal BLAnK level
- DATA <7:0>

131. ADDRESS A6

- 1) EUSC <7:0> : Encoder U(B-Y) Signal burst level Control
- DATA <7:0>

132. ADDRESS A7

- 1) EVSC <7:0> : Encoder V(R-Y) Signal burst level Control
- DATA <7:0>
- RANGE : 0 ~ 80 RE

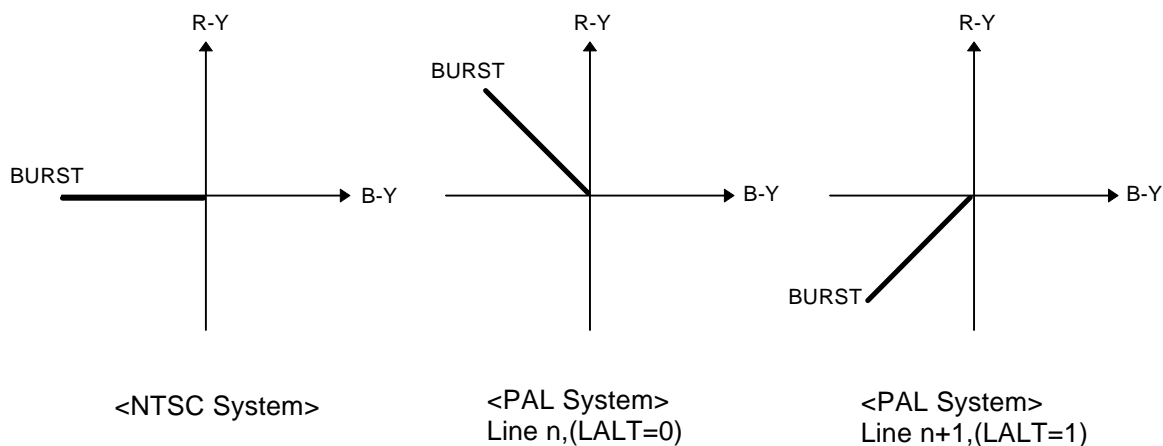

133. ADDRESS A8

- 1) EBMCK_SEL: Encoder balanced modulation clock selection
- DATA <7>

EBMCK_SEL = "0"	Select FSC clock
EBMCK_SEL = "1"	Select 4FSC clock

- 2) EDLY_SEL <3:0> : Encoder Delay Selection
- DATA <5:2>

EDLY_SEL <3><2><1><0>	DELAY
X X 0 0	0 Delays for CSYNCO
X X 0 1	1 Delays for CSYNCO
X X 1 0	2 Delays for CSYNCO
X X 1 1	3 Delays for CSYNCO
0 0 X X	0 Delays for BFO
0 1 X X	1 Delays for BFO
1 0 X X	2 Delays for BFO
1 1 X X	3 Delays for BFO

- 3) EBFDLY <1:0> : Encoder BF signalDeLaY Selection
- DATA <2:0>

EBFDLY <2><1><0>	Delay	EBFDLY <2><1><0>	Delay
0 0 0	0 Delays	1 0 0	4 Delays
0 0 1	1 Delays	1 0 1	5 Delays
0 1 0	2 Delays	1 1 0	6 Delays
0 1 1	3 Delays	1 1 1	7 Delays

134. ADDRESS A9

- 1) EFSC_CONT: Encoder FSC clock control
- DATA <2>

EFSC_CONT = "0"	Pass the FSC clock
EFSC_CONT = "1"	Invert the FSC clock

- 2) EFSC2_CONT: Encoder FSC2 clock control
- DATA <1>

EFSC2_CONT = "0"	Pass the FSC2 clock
EFSC2_CONT = "1"	Invert the FSC2 clock

3) EFSC_RN_SEL: Encoder FSC reset selection
 - DATA <0>

EFSC_RN_SEL = "0"	Only system reset
EFSC_RN_SEL = "1"	System reset & Reset pulse each 4 HD

135. ADDRESS E0

1) CBHN <7:0> : Color difference signal (B-Y) Hue Control Negative Gain
 - DATA <7:0>
 - RANGE : 00H ~ 7FH (-1X ~ 1X, 2 'S complement

136. ADDRESS FA

1) S1 <7:0> : Delay Control Selection
 - DATA <3:0>

S<3> <2><1><0>	Delay	S<3> <2><1><0>	Delay
x x 0 0	4 Delays for HD	0 0 x x	4 Delays for PBLK
x x 0 1	5 Delays for HD	0 1 x x	3 Delays for PBLK
x x 1 0	6 Delays for HD	1 0 x x	2 Delays for PBLK
x x 1 1	7 Delays for HD	1 1 x x	1 Delays for PBLK

137. ADDRESS FB

1) S2 <7:0> : Delay Control Selection
 - DATA <5:0>

S <5><4><3><2><1><0>	MODE	S <5><4><3><2><1><0>	MODE
x x x x 0 0	36 Delays for CBLK	x x 1 0 x x	38 Delays for CSYNK
x x x x 0 1	37 Delays for CBLK	x x 1 1 x x	39 Delays for CSYNK
x x x x 1 0	38 Delays for CBLK	0 0 x x x x	36 Delays for BF
x x x x 1 1	39 Delays for CBLK	0 1 x x x x	37 Delays for BF
x x 0 0 x x	36 Delays for CSYNK	1 0 x x x x	38 Delays for BF
x x 0 1 x x	37 Delays for CSYNK	1 1 x x x x	39 Delays for BF

* KS7314 have to Delay Control variably with considering Delay of ENCODER and DAC.

138. ADDRESS FC

- 1) TSTCMD <7:0> : Test Command
- DATA <7:0>

139. ADDRESS FD

- 1) FCM : FCM mode
- DATA <7>

FCM = "0"	No FCM mode
FCM = "1"	FCM mode

- 2) HSYNC <2:0> : HSYNC delay Selection
- DATA <5:3>

HSYNC <2><1><0>	DELAY
0 0 0	0 Delays
0 0 1	+1 Delays
0 1 0	+2 Delays
0 1 1	+3 Delays

HSYNC <2><1><0>	DELAY
1 0 0	-4 Delays
1 0 1	-3 Delays
1 1 0	-2 Delays
1 1 1	-1 Delays

140. ADDRESS FE

- 1) LALT_CONT : LALT signal Control forkasan
- DATA <7>

LALT_CONT = "0"	Pass the LALT
LALT_CONT = "1"	Invert the LALT

- 2) XCK_CONT : External Clock Control forkasan
- DATA <6>

XCK_CONT = "0"	Pass the Clock
XCK_CONT = "1"	Invert the Clock

- 3) MMSEL : MultiMedia Selection
- DATA <4>

MMSEL = "0"	Normal Operation
MMSEL = "1"	Multi-Media Mode

- 4) HSEL : Horizontal SElection
- DATA <3>

5) VSEL : Vertical SElection

- DATA <2>

HSEL	SCK	CCD INPUT	VSEL	ID	CCD INPUT
0	0	S2	0	0	CR
	1	S1		1	CB
1	0	S1	1	0	CB
	1	S2		1	CR

6) SCK_CONT : S-Clock CONTrol

- DATA <1>

7) UVCK_CONT : UV-Clock CONTrol

- DATA <0>

SCK_CONT, UVCK_CONT	OPERATION
0	Pass The Clock
1	Invert The Clock

141. ADDRESS FF

1) SYNC_SH : SYNC wave SHape

- DATA <7>

SYNC_SH = "0"	Sync wave No Shaping mode
SYNC_SH = "1"	Sync wave Shaping mode

2) EXT_DAC : Used External DA Converter

- DATA <6>

EXT_DAC	OPERATION
0	Using Internal DAC
1	Using External DAC

3) C422 : 4:2:2 mode for test

- DATA <5>

C422 = "0"	Select 4 Bit Chroma Output
C422 = "1"	Select 8 Bit Chroma Output

4) WIDE mode

- DATA <4>

WIDE = "0"	Not WIDE mode
WIDE = "1"	WIDE mode

- 5) OLPFSEL : LPF Selection for OPT_DETECT
- DATA <3>

OLPFSEL = "0"	$H(Z) = 0.25 + 0.5Z^1 + 0.25Z^2$
OLPFSEL = "1"	$H(Z) = 0.03125 + 0.25Z^1 + 0.25Z^2 + 0.25Z^3 + 0.25Z^4 + 0.03125Z^5$

- 6) PAL : PAL mode
- DATA <2>

PAL = "0"	NTSC mode
PAL = "1"	PAL mode

- 7) HI8 : Hiband 8mm mode
- DATA <1>

HI8 = "0"	Normal mode
HI8 = "1"	Hiband 8mm mode

- 8) DZ : Digital Zoom mode
- DATA <0>

DZ = "0"	Not Digital Zoom mode
DZ = "1"	Digital Zoom mode

PACKAGE DIMENSION

100 - QFP - 1414

unit: mm

