

# 1

## PRODUCT OVERVIEW

### OVERVIEW

Samsung's S3C4510B 16/32-bit RISC microcontroller is a cost-effective, high-performance microcontroller solution for Ethernet-based systems. An integrated Ethernet controller, the S3C4510B, is designed for use in managed communication hubs and routers.

The S3C4510B is built around an outstanding CPU core: the 16/32-bit ARM7TDMI RISC processor designed by Advanced RISC Machines, Ltd. The ARM7TDMI core is a low-power, general purpose microprocessor macro-cell that was developed for use in application-specific and custom-specific integrated circuits. Its simple, elegant, and fully static design is particularly suitable for cost-sensitive and power-sensitive applications.

The S3C4510B offers a configurable 8K-byte unified cache/SRAM and Ethernet controller which reduces total system cost. Most of the on-chip function blocks have been designed using an HDL synthesizer and the S3C4510B has been fully verified in Samsung's state-of-the-art ASIC test environment.

Important peripheral functions include two HDLC channels with buffer descriptor, two UART channels, 2-channel GDMA, two 32-bit timers, and 18 programmable I/O ports. On-board logic includes an interrupt controller, DRAM/SDRAM controller, and a controller for ROM/SRAM and flash memory. The System Manager includes an internal 32-bit system bus arbiter and an external memory controller.

The following integrated on-chip functions are described in detail in this user's manual:

- 8K-byte unified cache/SRAM
- I<sup>2</sup>C interface
- Ethernet controller
- HDLC
- GDMA
- UART
- Timers
- Programmable I/O ports
- Interrupt controller

## FEATURES

### Architecture

- Integrated system for embedded ethernet applications
- Fully 16/32-bit RISC architecture
- Little/Big-Endian mode supported basically, the internal architecture is big-endian. So, the little-endian mode only support for external memory.
- Efficient and powerful ARM7TDMI core
- Cost-effective JTAG-based debug solution
- Boundary scan

### System Manager

- 8/16/32-bit external bus support for ROM/SRAM, flash memory, DRAM, and external I/O
- One external bus master with bus request/acknowledge pins
- Support for EDO/normal or SDRAM
- Programmable access cycle (0-7 wait cycles)
- Four-word depth write buffer
- Cost-effective memory-to-peripheral DMA interface

### Unified Instruction/Data Cache

- Two-way, set-associative, unified 8K-byte cache
- Support for LRU (least recently used) protocol
- Cache is configurable as an internal SRAM

### I<sup>2</sup>C Serial Interface

- Master mode operation only
- Baud rate generator for serial clock generation

### Ethernet Controller

- DMA engine with burst mode
- DMA Tx/Rx buffers (256 bytes Tx, 256 bytes Rx)
- MAC Tx/Rx FIFO buffers (80 bytes Tx, 16 bytes Rx)

- Data alignment logic
- Endian translation
- 100/10-Mbit per second operation
- Full compliance with IEEE standard 802.3
- MII and 7-wire 10-Mbps interface
- Station management signaling
- On-chip CAM (up to 21 destination addresses)
- Full-duplex mode with PAUSE feature
- Long/short packet modes
- PAD generation

### HDLCs

- HDLC protocol features:
  - Flag detection and synchronization
  - Zero insertion and deletion
  - Idle detection and transmission
  - FCS generation and detection (16-bit)
  - Abort detection and transmission
- Address search mode (expandable to 4 bytes)
- Selectable CRC or No CRC mode
- Automatic CRC generator preset
- Digital PLL block for clock recovery
- Baud rate generator
- NRZ/NRZI/FM/Manchester data formats for Tx/Rx
- Loop-back and auto-echo modes
- Tx/Rx FIFOs have 8-word (8 × 32-bit) depth
- Selectable 1-word or 4-word data transfer mode
- Data alignment logic
- Endian translation
- Programmable interrupts
- Modem interface
- Up to 10 Mbps operation
- HDLC frame length based on octets
- 2-channel DMA buffer descriptor for Tx/Rx on each HDLC

**DMA Controller**

- 2-channel General DMA for memory-to-memory, memory-to-UART, UART-to-memory data transfers without CPU intervention
- Initiated by a software or external DMA request
- Increments or decrements a source or destination address in 8-bit, 16-bit or 32-bit data transfers
- 4-data burst mode

**UARTs**

- Two UART (serial I/O) blocks with DMA-based or interrupt-based operation
- Support for 5-bit, 6-bit, 7-bit, or 8-bit serial data transmit and receive
- Programmable baud rates
- 1 or 2 stop bits
- Odd or even parity
- Break generation and detection
- Parity, overrun, and framing error detection
- ×16 clock mode
- Infra-red (IR) Tx/Rx support (IrDA)

**Timers**

- Two programmable 32-bit timers
- Interval mode or toggle mode operation

**Programmable I/O**

- 18 programmable I/O ports
- Pins individually configurable to input, output, or I/O mode for dedicated signals

**Interrupt Controller**

- 21 interrupt sources, including 4 external interrupt sources
- Normal or fast interrupt mode (IRQ, FIQ)
- Prioritized interrupt handling

**PLL**

- The external clock can be multiplied by on-chip PLL to provide high frequency system clock
- The input frequency range is 10–40 MHz
- The output frequency is 5 times of input clock. To get 50 MHz, input clock frequency should be 10 MHz.

**Operating Voltage Range**

- 3.3 V ± 5 %

**Operating Temperature Range**

- 0 °C to + 70 °C

**Operating Frequency**

- Up to 50 MHz

**Package Type**

- 208-Pin QFP

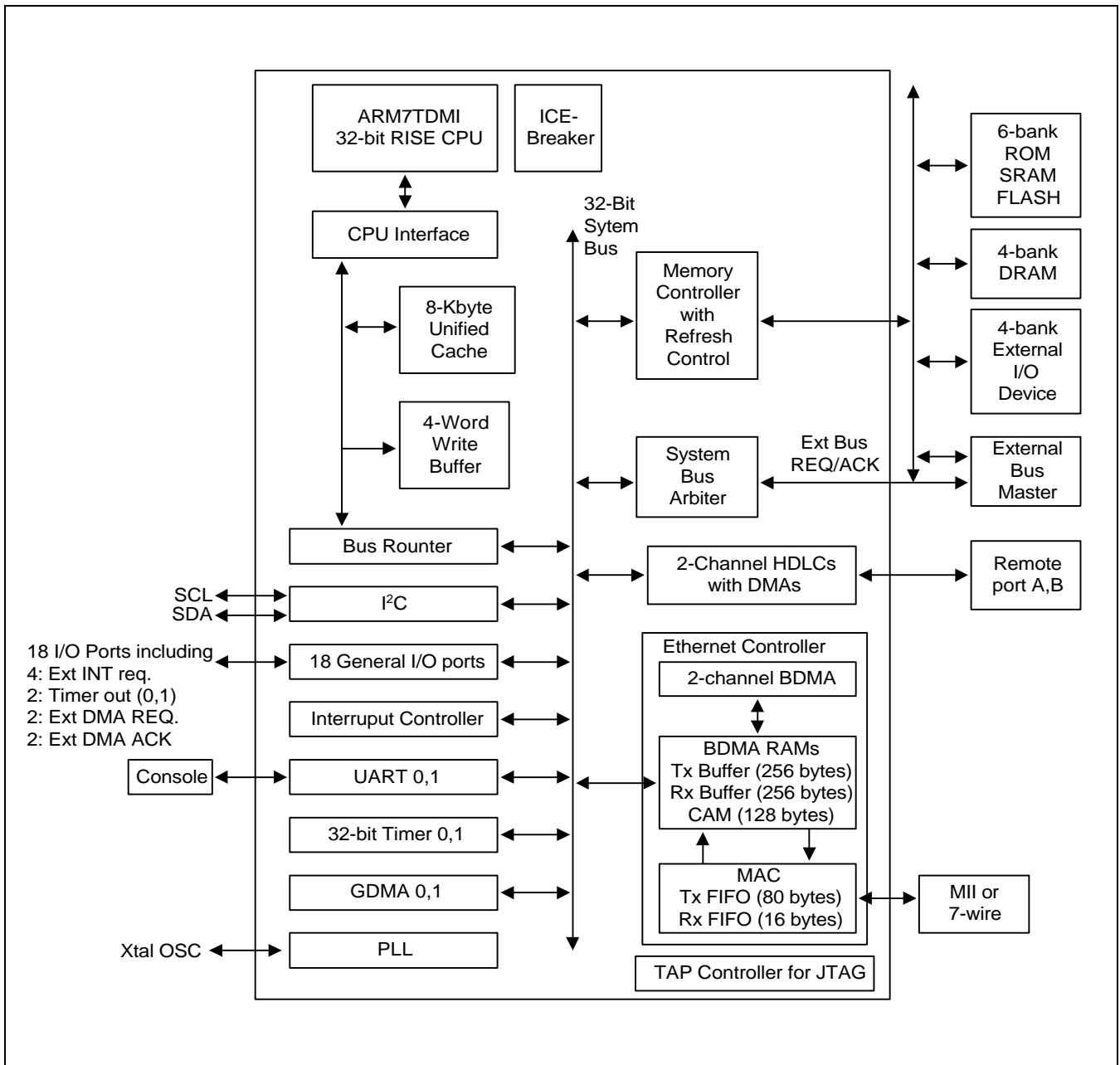

Figure 1-1. S3C4510B Block Diagram

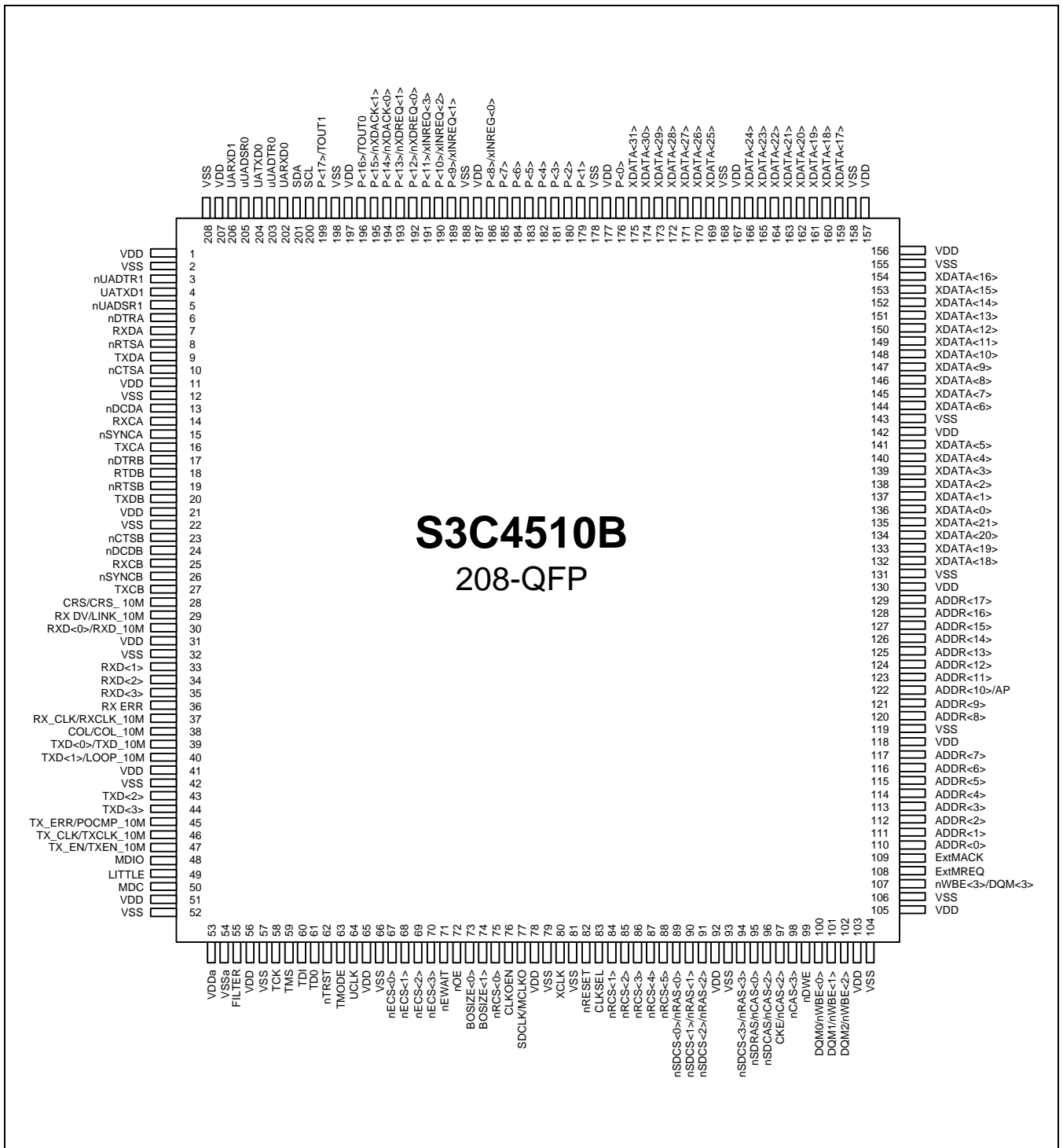

Figure 1-2. S3C4510B Pin Assignment Diagram

## SIGNAL DESCRIPTIONS

Table 1-1. S3C4510B Signal Descriptions

Signal	Pin No.	Type	Description
XCLK	80	I	S3C4510B system clock source. If CLKSEL is Low, PLL output clock is used as the S3C4510B internal system clock. If CLKSEL is High, XCLK is used as the S3C4510B internal system clock.
MCLKO/SDCLK <sup>(note)</sup>	77	O	System clock out. MCLKO is monitored with some delay as the same phase of internal system clock, MCLK(SCLK). SDCLK is system clock for SDRAM.
CLKSEL	83	I	Clock select. When CLKSEL is '0'(low level), PLL output clock can be used as the master clock. When CLKSEL is '1'(high level), the XCLK is used as the master clock.
nRESET	82	I	Not reset. nRESET is the global reset input for the S3C4510B. To allow a system reset, and for internal digital filtering, nRESET must be held to low level for at least 64 master clock cycles. Refer to "Figure 3. S3C4510B reset timing diagram" for more details about reset timing.
CLKOEN	76	I	Clock out enable/disable. (see the pin description for MCLKO.)
TMODE	63	I	Test Mode. The TMODE bit settings are interpreted as follows: '0' = normal operating mode, '1' = chip test mode. This TMODE pin also can be used to change MF of PLL. To get 5 times internal system clock from external clock, '0'(low level) should be assigned to TMODE. If '1'(high level), MF will be changed to 6.6
FILTER	55	AI	If the PLL is used, 820pF ceramic capacitor should be connected between the pin and analog ground(pin # 54).
TCK	58	I	JTAG Test Clock. The JTAG test clock shifts state information and test data into, and out of, the S3C4510B during JTAG test operations. This pin is internally connected pull-down.
TMS	59	I	JTAG Test Mode Select. This pin controls JTAG test operations in the S3C4510B. This pin is internally connected pull-up.
TDI	60	I	JTAG Test Data In. The TDI level is used to serially shift test data and instructions into the S3C4510B during JTAG test operations. This pin is internally connected pull-up.
TDO	61	O	JTAG Test Data Out. The TDO level is used to serially shift test data and instructions out of the S3C4510B during JTAG test operations.
nTRST	62	I	JTAG Not Reset. Asynchronous reset of the JTAG logic. This pin is internally connected pull-up.

Table 1-1. S3C4510B Signal Descriptions (Continued)

Signal	Pin No.	Type	Description
ADDR[21:0]/ ADDR[10]/AP (note)	117–110, 129–120, 135–132	O	Address Bus. The 22-bit address bus, ADDR[21:0], covers the full 4M word address range of each ROM/SRAM, flash memory, DRAM, and the external I/O banks. The 23-bit internal address bus used to generate DRAM address. The number of column address bits in DRAM bank can be programmed 8bits to 11bits use by DRAMCON registers. ADDR[10]/AP is the auto precharge control pin. The auto precharge command is issued at the same time as burst read or burst write by asserting high on ADDR[10]/AP.
XDATA[31:0]	141–136, 154–144, 166–159, 175–169	I/O	External (bi-directional, 32-bit) Data Bus. The S3C4510B data bus supports external 8-bit, 16-bit, and 32-bit bus sizes.
nRAS[3:0]/ nSDCS[3:0] (note)	94, 91, 90, 89	O	Not Row Address Strobe for DRAM. The S3C4510B supports up to four DRAM banks. One nRAS output is provided for each bank. nSDCS[3:0] are chip select pins for SDRAM.
nCAS[3:0] nCAS[0]/nSDRAS nCAS[1]/nSDCAS nCAS[2]/CKE (note)	98, 97, 96, 95	O	Not column address strobe for DRAM. The four nCAS outputs indicate the byte selections whenever a DRAM bank is accessed. nSDRAS is row address strobe signal for SDRAM. Latches row addresses on the positive going edge of the SDCLK with nSDRAS low. Enable row access and precharge. nSDCAS is column address strobe for SDRAM. Latches column addresses on the positive going edge of the SDCLK with nSDCAS low. Enables column access. CKE is clock enable signal for SDRAM. Masks SDRAM system clock, SDCLK to freeze operation from the next clock cycle. SDCLK should be enabled at least one cycle prior to new command. Disable input buffers of SDRAM for power down in standby.
nDWE	99	O	DRAM Not Write Enable. This pin is provided for DRAM bank write operations. (nWBE[3:0] is used for write operations to the ROM/ SRAM/flash memory banks.) .
nECS[3:0]	70, 69, 68, 67	O	Not External I/O Chip Select. Four external I/O banks are provided for external memory-mapped I/O operations. Each I/O bank stores up to 16 Kbytes. nECS signals indicate which of the four external I/O banks is selected.
nEWAIT	71	I	Not External Wait. This signal is activated when an external I/O device or ROM/SRAM/flash bank 5 needs more access cycles than those defined in the corresponding control register. When de-assert the nEWAIT, you must synchronize the nEWAIT with MCLKO rising edge. If not, memory state machine can get into the Wrong State.

Table 1-1. S3C4510B Signal Descriptions (Continued)

Signal	Pin No.	Type	Description
nRCS[5:0]	88-84, 75	O	Not ROM/SRAM/Flash Chip Select. The S3C4510B can access up to six external ROM/SRAM/Flash banks. By controlling the nRCS signals, you can map CPU addresses into the physical memory banks.
BOSIZE[1:0]	74, 73	I	Bank 0 Data Bus Access Size. Bank 0 is used for the boot program. You use these pins to set the size of the bank 0 data bus as follows: '01' = one byte, '10' = half-word, '11' = one word, and '00' = reserved.
nOE	72	O	Not Output Enable. Whenever a memory access occurs, the nOE output controls the output enable port of the specific memory device.
nWBE[3:0]/ DQM[3:0] (note)	107, 102–100	O	Not Write Byte Enable. Whenever a memory write access occurs, the nWBE output controls the write enable port of the specific memory device (except for DRAM). For DRAM banks, CAS[3:0] and nDWE are used for the write operation. DQM is data input/output mask signal for SDRAM.
ExtMREQ	108	I	External Bus Master Request. An external bus master uses this pin to request the external bus. When it activates the ExtMREQ signal, the S3C4510B drives the state of external bus pins to high impedance. This lets the external bus master take control of the external bus. When it has the control, the external bus master assumes responsibility for DRAM refresh operations. The ExtMREQ signal is deactivated when the external bus master releases the external bus. When this occurs, ExtMACK goes Low level and the S3C4510B assumes the control of the bus.
ExtMACK	109	O	External Bus Acknowledge. (See the ExtMREQ pin description.)
MDC	50	O	Management Data Clock. The signal level at the MDC pin is used as a timing reference for data transfers that are controlled by the MDIO signal.
MDIO	48	I/O	Management Data I/O. When a read command is being executed, data that is clocked out of the PHY is presented on this pin. When a write command is being executed, data that is clocked out of the controller is presented on this pin for the Physical Layer Entity, PHY.
LITTLE	49	I	Little endian mode select pin. If LITTLE is High, S3C4510B operate in little endian mode. If Low, then in Big endian mode. Default value is low because this pin is pull-downed internally.
COL/COL_10M	38	I	Collision Detected/Collision Detected for 10M. COL is asserted asynchronously with minimum delay from the start of a collision on the medium in MII mode. COL_10M is asserted when a 10-Mbit/s PHY detects a collision.
TX_CLK/ TXCLK_10M	46	I	Transmit Clock/Transmit Clock for 10M. The controller drives TXD[3:0] and TX_EN from the rising edge of TX_CLK. In MII mode, the PHY samples TXD[3:0] and TX_EN on the rising edge of TX_CLK. For data transfers, TXCLK_10M is provided by the 10-Mbit/s PHY.



Table 1-1. S3C4510B Signal Descriptions (Continued)

Signal	Pin No.	Type	Description
TXD[3:0] LOOP_10M TXD_10M	44, 43, 40, 39	O	Transmit Data/Transmit Data for 10 M/Loop-back for 10M. Transmit data is aligned on nibble boundaries. TXD[0] corresponds to the first bit to be transmitted on the physical medium, which is the LSB of the first byte and the fifth bit of that byte during the next clock. TXD_10M is shared with TXD[0] and is a data line for transmitting to the 10-Mbit/s PHY. LOOP_10M is shared with TXD[1] and is driven by the loop-back bit in the control register.
TX_EN/ TXEN_10M	47	O	Transmit Enable/Transmit Enable for 10M. TX_EN provides precise framing for the data carried on TXD[3:0]. This pin is active during the clock periods in which TXD[3:0] contains valid data to be transmitted from the preamble stage through CRC. When the controller is ready to transfer data, it asserts TXEN_10M.
TX_ERR/ PCOMP_10M	45	O	Transmit Error/Packet Compression Enable for 10M. TX_ERR is driven synchronously to TX_CLK and sampled continuously by the Physical Layer Entity, PHY. If asserted for one or more TX_CLK periods, TX_ERR causes the PHY to emit one or more symbols which are not part of the valid data, or delimiter set located somewhere in the frame that is being transmitted. PCOMP_10M is asserted immediately after the packet's DA field is received. PCOMP_10M is used with the Management Bus of the DP83950 Repeater Interface Controller (from National Semiconductor). The MAC can be programmed to assert PCOMP if there is a CAM match, or if there is not a match. The RIC (Repeater Interface Controller) uses this signal to compress (shorten) the packet received for management purposes and to reduce memory usage. (See the DP83950 Data Sheet, published by National Semiconductor, for details on the RIC Management Bus.) This pin is controlled by a special register, with which you can define the polarity and assertion method (CAM match active or not match active) of the PCOMP signal.
CRS/CRS_10M	28	I	Carrier Sense/Carrier Sense for 10M. CRS is asserted asynchronously with minimum delay from the detection of a non-idle medium in MII mode. CRS_10M is asserted when a 10-Mbit/s PHY has data to transfer. A 10-Mbit/s transmission also uses this signal.
RX_CLK/ RXCLK_10M	37	I	Receive Clock/Receive Clock for 10M. RX_CLK is a continuous clock signal. Its frequency is 25 MHz for 100-Mbit/s operation, and 2.5 MHz for 10-Mbit/s. RXD[3:0], RX_DV, and RX_ERR are driven by the PHY off the falling edge of RX_CLK, and sampled on the rising edge of RX_CLK. To receive data, the TXCLK_10 M clock comes from the 10-Mbit/s PHY.
RXD[3:0]/ RXD_10M	35, 34, 33, 30	I	Receive Data/Receive Data for 10M. RXD is aligned on nibble boundaries. RXD[0] corresponds to the first bit received on the physical medium, which is the LSB of the byte in one clock period and the fifth bit of that byte in the next clock. RXD_10M is shared with RXD[0] and it is a line for receiving data from the 10-Mbit/s PHY.

Table 1-1. S3C4510B Signal Descriptions (Continued)

Signal	Pin No.	Type	Description
RX_DV/LINK_10M	29	I	Receive Data Valid/Link Status for 10M. PHY asserts RX_DV synchronously, holding it active during the clock periods in which RXD[3:0] contains valid data received. PHY asserts RX_DV no later than the clock period when it places the first nibble of the start frame delimiter (SFD) on RXD[3:0]. If PHY asserts RX_DV prior to the first nibble of the SFD, then RXD[3:0] carries valid preamble symbols. LINK_10M is shared with RX_DV and used to convey the link status of the 10-Mbit/s endec. The value is stored in a status register.
RX_ERR	36	I	Receive Error. PHY asserts RX_ERR synchronously whenever it detects a physical medium error (e.g., a coding violation). PHY asserts RX_ERR only when it asserts RX_DV.
TXDA	9	O	HDLC Ch-A Transmit Data. The serial output data from the transmitter is coded in NRZ/NRZI/FM/Manchester data format.
RXDA	7	I	HDLC Ch-A Receive Data. The serial input data received by the device should be coded in NRZ/NRZI/FM/Manchester data format. The data rate should not exceed the rate of the S3C4510B internal master clock.
nDTRA	6	O	HDLC Ch-A Data Terminal Ready. nDTRA output indicates that the data terminal device is ready for transmission and reception.
nRTSA	8	O	HDLC Ch-A Request To Send. The nRTSA output goes low when there is exist data to be sent in TxFIFO. The data to be sent is transmitted when the nCTS is active(Low) state.
nCTSA	10	I	HDLC Ch-A Clear To Send. The S3C4510B stores each transition of nCTS to ensure that its occurrence would be acknowledged by the system.
nDCDA	13	I	HDLC Ch-A Data Carrier Detected. A High level on this pin resets and inhibits the receiver register. Data from a previous frame that may remain in the RxFIFO is retained. The S3C4510B stores each transition of nDCD.
nSYNCA	15	O	HDLC Ch-A Sync is detected. This indicates the reception of a flag. The nSYNC output goes low for one bit time beginning at the last bit of the flag.
RXCA	14	I	HDLC Ch-A Receiver Clock. When this clock input is used as the receiver clock, the receiver samples the data on the positive edge of RXCA clock. This clock can be the source clock of the receiver, the baud rate generator, or the DPLL.
TXCA	16	I/O	HDLC Ch-A Transmitter Clock. When this clock input is used as the transmitter clock, the transmitter shifts data on the negative transition of the TXCA clock . If you do not use TXCA as the transmitter clock, you can use it as an output pin for monitoring internal clocks such as the transmitter clock, receiver clock, and baud rate generator output clocks.
TXDB	20	O	HDLC Ch-B transmit data. See the TXDA pin description.
RXDB	18	I	HDLC Ch-B receive data. See the RXDA pin description.

Table 1-1. S3C4510B Signal Descriptions (Continued)

Signal	Pin No.	Type	Description
nDTRB	17	O	HDLC Ch-B data terminal ready. See the nDTRA pin description.
nRTSB	19	O	HDLC Ch-B request to send. See the nRTSA pin description.
nCTSB	23	I	HDLC Ch-B clear to send. See the nCTSA pin description.
nDCDB	24	I	HDLC Ch-B data carrier detected. See the nDCDA pin description.
nSYNCB	26	O	HDLC Ch-B sync is detected. See the nSYNCA pin description.
RXCB	25	I	HDLC Ch-B receiver clock. See the RXCA pin description.
TXCB	27	I/O	HDLC Ch-B transmitter clock. See the TXCA pin description.
UCLK	64	I	The external UART clock input. MCLK or PLL generated clock can be used as the UART clock. You can use UCLK, with an appropriate divided by factor, if a very precious baud rate clock is required.
UARXD0	202	I	UART0 receive data. RXD0 is the UART 0 input signal for receiving serial data.
UATXD0	204	O	UART0 transmit data. TXD0 is the UART 0 output signal for transmitting serial data.
nUADTR0	203	I	Not UART0 data terminal ready. This input signals the S3C4510B that the peripheral (or host) is ready to transmit or receive serial data.
nUADSR0	205	O	Not UART0 data set ready. This output signals the host (or peripheral) that UART 0 is ready to transmit or receive serial data.
UARXD1	206	I	UART1 receive data. See the RXD0 pin description.
UATXD1	4	O	UART1 transmit data. See the TXD0 pin description.
nUADTR1	3	I	Not UART1 data terminal ready. See the DTR0 pin description.
nUADSR1	5	O	Not UART1 data set ready. See the DSR0 pin description.
P[7:0]	185–179, 176	I/O	General I/O ports. See the I/O ports, chapter 12.
XINTREQ[3:0] P[11:8]	191–189, 186	I/O	External interrupt request lines or general I/O ports. See the I/O ports, chapter 12.
nXDREQ[1:0]/ P[13:12]	193, 192	I/O	Not external DMA requests for GDMA or general I/O ports. See the I/O ports, chapter 12.
nXDACK[1:0] P[15:14]	195, 194	I/O	Not external DMA acknowledge from GDMA or general I/O ports. See the I/O ports, chapter 12.
TOUT0/P[16]	196	I/O	Timer 0 out or general I/O port. See the I/O ports, chapter 12.
TOUT1/P[17]	199	I/O	Timer 1 out or general I/O port. See the I/O ports, chapter 12.
SCL	200	I/O	I <sup>2</sup> C serial clock.
SDA	201	I/O	I <sup>2</sup> C serial data.

Table 1-1. S3C4510B Signal Descriptions (Continued)

Signal	Pin No.	Type	Description
VDDP	1, 21, 41, 56, 78, 92, 105, 118, 130, 155, 167, 177, 197	Power	I/O pad power
VDDI	11, 31, 51, 65, 103, 142, 157, 187, 207	Power	Internal core power
VSSP	2, 22, 42, 57, 79, 81, 93, 106, 119, 131, 156, 168, 178, 198	GND	I/O pad ground
VSSI	12, 32, 52, 66, 104, 143, 158, 188, 208	GND	Internal core ground
VDDA	53	Power	Analog power for PLL
VSSA/VBBA	54	GND	Analog/bulk ground for PLL

**NOTE:** SDRAM or EDO/normal DRAM interface signal pins are shared functions. It's functions will be configured by SYSCFG[31].

Table 1-2. S3C4510B Pin List and PAD Type

Group	Pin Name	Pin Counts	I/O Type	Pad Type	Description
System	XCLK	1	I	ptic	S3C4510B system source clock.
Configuration (8)	MCLKO	1	O	pob4	System clock out.
	CLKSEL	1	I	ptic	Clock select.
	nRESET	1	I	ptis	Not reset
	CLKOEN	1	I	ptic	Clock out enable/disable.
	TMODE	1	I	ptic	Test mode.
	LITTLE	1	I	pticd	Little endian mode select pin
	FILTER	1	I	pia_bb	PLL filter pin
	TAP Control (5)	TCK	1	I	ptic
TMS		1	I	pticu	JTAG test mode select.
TDI		1	I	pticu	JTAG test data in.
TDO		1	O	ptot2	JTAG test data out.
nTRST		1	I	pticu	JTAG not reset.
Memory Interface (83)	ADDR[21:0]	22	O	ptot6	Address bus.
	XDATA[31:0]	32	I/O	ptbsut6	External, bi-directional, 32-bit data bus.
	nRAS[3:0]	4	O	ptot4	Not row address strobe for DRAM.
	nCAS[3:0]	4	O	ptot4	Not column address strobe for DRAM.
	nDWE	1	O	ptot4	Not write enable
	nECS[3:0]	4	O	ptot4	Not external I/O chip select.
	nEWAIT	1	I	ptic	Not external wait signal.
	nRCS[5:0]	6	O	ptot4	Not ROM/SRAM/flash chip select.
	B0SIZE[1:0]	2	I	ptic	Bank 0 data bus access size.
	nOE	1	O	ptot4	Not output enable.
	nWBE[3:0]	4	O	ptot4	Not write byte enable.
	ExtMREQ	1	I	ptic	External master bus request.
	ExtMACK	1	O	pob1	External bus acknowledge.

Table 1-2. S3C4510B Pin List and PAD Type (Continued)

Group	Pin Name	Pin Counts	I/O Type	Pad Type	Description
Ethernet Controller (18)	MDC	1	O	pob4	Management data clock.
	MDIO	1	I/O	ptbcut4	Management data I/O.
	COL/ COL_10M	1	I	ptis	Collision detected/collision detected for 10 M.
	TX_CLK/ TXCLK_10M	1	I	ptis	Transmit data/transmit data for 10 M.
	TXD[3:0]/ TXD_10M LOOP_10M	4	O	pob4	Transmit data/transmit data for 10 M.
	TX_EN/ TXEN_10M	1	O	pob4	Transmit enable or transmit enable for 10 M.
	TX_ERR/ PCOMP_10M	1	O	pob4	Transmit error/packet compression enable for 10 M.
	CRS/ CRS_10M	1	I	ptis	Carrier sense/carrier sense for 10 M.
	RX_CLK/ RXCLK_10M	1	I	ptis	Receive clock/receive clock for 10 M.
	RXD[3:0]/ RXD_10M	4	I	ptis	Receive data/receive data for 10 M.
	RX_DV/ LINK_10M	1	I	ptis	Receive data valid.
	RX_ERR	1	I	ptis	Receive error.
HDLC Channel A (9)	TXDA	1	O	pob4	HDLC channel A transmit data.
	RXDA	1	I	ptis	HDLC channel A receive data.
	nDTRA	1	O	pob4	HDLC channel A data terminal ready.
	nRTSA	1	O	pob4	HDLC channel A request to send.
	nCTSA	1	I	ptis	HDLC channel A clear to send.
	nDCDA	1	I	ptis	HDLC channel A data carrier detected.
	nSYNCA	1	O	pob4	HDLC channel A sync is detected.
	RXCA	1	I	ptis	HDLC channel A receiver clock.
TXCA	1	I/O	ptbsut1	HDLC channel A transmitter clock.	
HDLC Channel B (9)	TXDB	1	O	pob4	HDLC channel B transmit data.
	RXDB	1	I	ptis	HDLC channel B receive data.
	nDTRB	1	O	pob4	HDLC channel B data terminal ready.
	nRTSB	1	O	pob4	HDLC channel B request to send.
	nCTSB	1	I	ptis	HDLC channel B clear to send.
	nDCDB	1	I	ptis	HDLC channel B data carrier detected.
	nSYNCB	1	O	pob4	HDLC channel B sync is detected.
	RXCB	1	I	ptis	HDLC channel B receiver clock.
TXCB	1	I/O	ptbsut1	HDLC channel B transmitter clock.	

Table 1-2. S3C4510B Pin List and PAD Type (Continued)

Group	Pin Name	Pin Counts	I/O Type	Pad Type	Description
UART 0 (5)	UCLK	1	I	ptis	UART External Clock for UART0/UART1
	UARXD0	1	I	ptic	UART 0 receive data.
	UATXD0	1	O	pob4	UART 0 transmit data.
	nUADTR0	1	I	ptic	Not UART 0 data terminal ready.
	nUADSR0	1	O	pob4	Not UART 0 data set ready.
UART 1 (4)	UARXD1	1	I	ptic	UART 1 receive data.
	UATXD1	1	O	pob4	UART 1 transmit data.
	nUADTR1	1	I	ptic	Not UART 1 data terminal ready.
	NUADSR1	1	O	pob4	Not UART 1 data set ready.
General- Purpose I/O (xINTREQ, nXDREQ, nXDACK Timer 0, 1) (18)	P[7:0]	8	I/O	ptbst4sm	General I/O ports.
	xINTREQ [3:0]/P[11:8]	4	I/O	ptbst4sm	External interrupt requests or general I/O ports.
	xXDREQ [1:0]/P[13:12]	2	I/O	ptbst4sm	External DMA requests for GDMA or general I/O ports.
	nXDACK[1:0] / P[15:14]	2	I/O	ptbst4sm	External DMA acknowledge from GDMA or general I/O ports.
	TIMER0/P [16]	1	I/O	ptbst4sm	Timer 0 out or general I/O port.
TIMER1/P [17]	1	I/O	ptbst4sm	Timer 1 out or general I/O port.	
I <sup>2</sup> C (2)	SCL	1	I/O	ptbcd4	I <sup>2</sup> C serial clock.
	SDA	1	I/O	ptbcd4	I <sup>2</sup> C serial data.

Table 1-3. S3C4510B PAD Type

Pad Type	I/O Type	Current Drive	Cell Type	Feature	Slew-Rate Control
ptic	I	–	LVC MOS level	5 V-tolerant	–
ptis	I	–	LVC MOS schmit trigger level	5 V-tolerant	–
pticu	I	–	LVC MOS level	5 V-tolerant Pull-up register	–
pticd	I	–	LVC MOS level	5 V-tolerant Pull-down register	–
pia_bb	I	–	Analog input with seperate bulk bias	–	–
pob1	O	1 mA	Normal buffer	–	–
ptot2	O	2 mA	Tri-state buffer	5 V-tolerant	–
pob4	O	4 mA	Normal buffer	–	–
ptot4	O	4 mA	Tri-state buffer	5 V-tolerant	–
ptot6	O	6 mA	Tri-state buffer	5 V-tolerant	–
ptbsut1	I/O	1 mA	LVC MOS schmit trigger level Tri-state buffer	5 V-tolerant Pull-up register	–
ptbcut4	I/O	4 mA	LVC MOS level Tri-state buffer	5 V-tolerant	Medium
ptbcd4	I/O	4 mA	LVC MOS level open drain buffer	5 V-tolerant	–
ptbst4sm	I/O	4 mA	LVC MOS schmit trigger level	5 V-tolerant	Medium
Ptbsut6	I/O	6 mA	LVC MOS schmit trigger level	5 V-tolerant Pull-up register	–

**NOTE:** pticu and pticd provides 100K Ohm Pull-up(down) register. For detail information about the pad type, see Chapter 4. Input/Output Cells of the "STD90/MDL90 0.35 um 3.3 V Standard Cell Library Data Book", produced by Samsung Electronic Co., Ltd, ASIC Team.

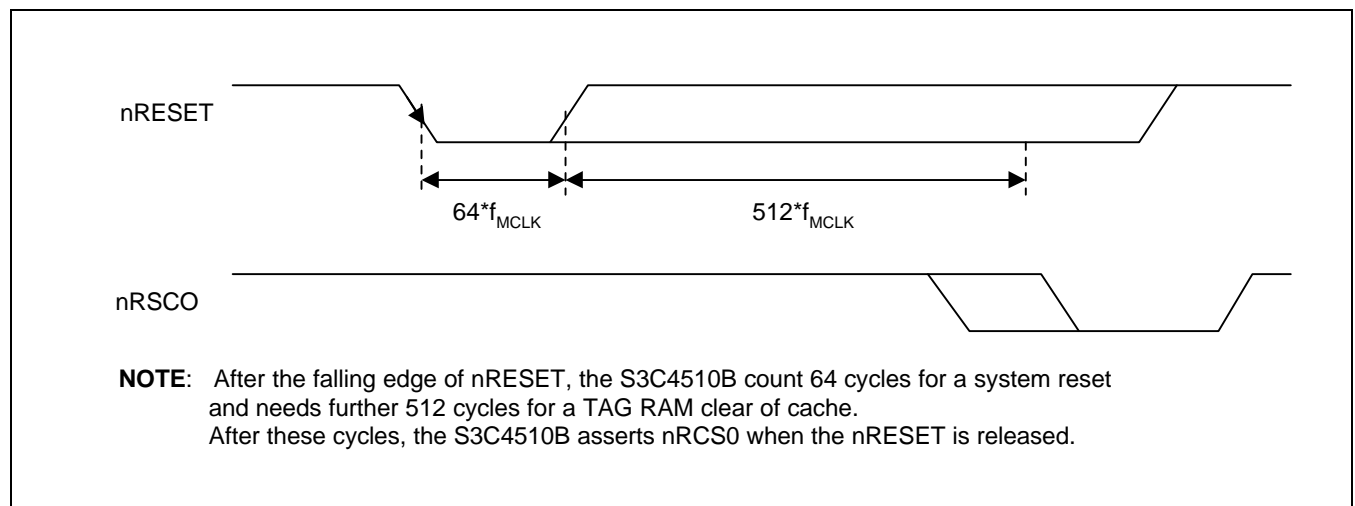

Figure 1-3. Reset Timing Diagram



## CPU CORE OVERVIEW

The S3C4510B CPU core is a general purpose 32-bit ARM7TDMI microprocessor, developed by Advanced RISC Machines, Ltd. (ARM). The core architecture is based on Reduced Instruction Set Computer (RISC) principles. The RISC architecture makes the instruction set and its related decoding mechanism simpler and more efficient than those with microprogrammed Complex Instruction Set Computer (CISC) systems. High instruction throughput and impressive real-time interrupt response are among the major benefits of the architecture. Pipelining is also employed so that all components of the processing and memory systems can operate continuously. The ARM7TDMI has a 32-bit address bus.

An important feature of the ARM7TDMI processor that makes itself distinct from the ARM7 processor is a unique architectural strategy called *THUMB*. The THUMB strategy is an extension of the basic ARM architecture consisting of 36 instruction formats. These formats are based on the standard 32-bit ARM instruction set, while having been re-coded using 16-bit wide opcodes.

As THUMB instructions are one-half the bit width of normal ARM instructions, they produce very high-density codes. When a THUMB instruction is executed, its 16-bit opcode is decoded by the processor into its equivalent instruction in the standard ARM instruction set. The ARM core then processes the 16-bit instruction as it would a normal 32-bit instruction. In other words, the THUMB architecture gives 16-bit systems a way to access the 32-bit performance of the ARM core without requiring the full overhead of 32-bit processing.

As the ARM7TDMI core can execute both standard 32-bit ARM instructions and 16-bit THUMB instructions, it allows you to mix the routines of THUMB instructions and ARM code in the same address space. In this way, you can adjust code size and performance, routine by routine, to find the best programming solution for a specific application.

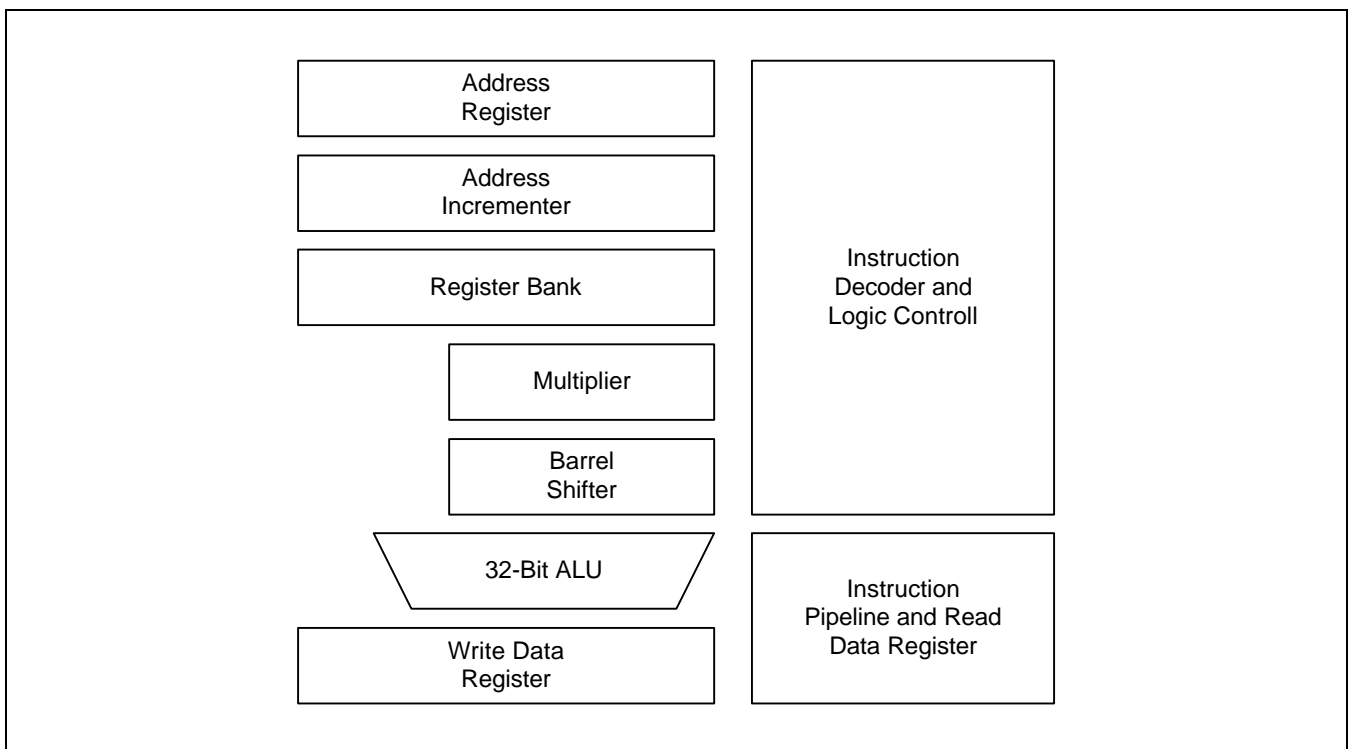

Figure 1-4. ARM7TDMI Core Block Diagram

## INSTRUCTION SET

The S3C4510B instruction set is divided into two subsets: a standard *32-bit ARM instruction set* and a *16-bit THUMB instruction set*.

The 32-bit ARM instruction set is comprised of thirteen basic instruction types, which can, in turn, be divided into four broad classes:

- Four types of branch instructions which control program execution flow, instruction privilege levels, and switching between an ARM code and a THUMB code.
- Three types of data processing instructions which use the on-chip ALU, barrel shifter, and multiplier to perform high-speed data operations in a bank of 31 registers (all with 32-bit register widths).
- Three types of load and store instructions which control data transfer between memory locations and the registers. One type is optimized for flexible addressing, another for rapid context switching, and the third for swapping data.
- Three types of co-processor instructions which are dedicated to controlling external co-processors. These instructions extend the off-chip functionality of the instruction set in an open and uniform way.

### NOTE

All 32-bit ARM instructions can be executed conditionally.

The 16-bit THUMB instruction set contains 36 instruction formats drawn from the standard 32-bit ARM instruction set. The THUMB instructions can be divided into four functional groups:

- Four branch instructions.
- Twelve data processing instructions, which are a subset of the standard ARM data processing instructions.
- Eight load and store register instructions.
- Four load and store multiple instructions.

### NOTE

Each 16-bit THUMB instruction has a corresponding 32-bit ARM instruction with an identical processing model.

The 32-bit ARM instruction set and the 16-bit THUMB instruction set are good targets for compilers of many different high-level languages. When an assembly code is required for critical code segments, the ARM programming technique is straightforward, unlike that of some RISC processors which depend on sophisticated compiler technology to manage complicated instruction interdependencies.

Pipelining is employed so that all parts of the processor and memory systems can operate continuously. Typically, while one instruction is being executed, its successor is being decoded, and the third instruction is being fetched from memory.

## MEMORY INTERFACE

The CPU memory interface has been designed to help the highest performance potential to be realized without incurring high costs in the memory system. Speed-critical control signals are pipelined so that system control functions can be implemented in standard low-power logic. These pipelined control signals allow you to fully exploit the fast local access modes, offered by industry standard dynamic RAMs.

## OPERATING STATES

From a programmer's point of view, the ARM7TDMI core is always in one of two operating states. These states, which can be switched by software or by exception processing, are:

- *ARM state* (when executing 32-bit, word-aligned, ARM instructions), and
- *THUMB state* (when executing 16-bit, half-word aligned THUMB instructions).

## OPERATING MODES

The ARM7TDMI core supports seven operating modes:

- *User mode*: a normal program execution state
- *FIQ (Fast Interrupt Request) mode*: for supporting a specific data transfer or channel processing
- *IRQ (Interrupt ReQuest) mode*: for general purpose interrupt handling
- *Supervisor mode*: a protected mode for the operating system
- *Abort mode*: entered when a data or instruction pre-fetch is aborted
- *System mode*: a privileged user mode for the operating system
- *Undefined mode*: entered when an undefined instruction is executed

Operating mode changes can be controlled by software. They can also be caused by external interrupts or exception processing. Most application programs execute in user mode. Privileged modes (that is, all modes other than User mode) are entered to service interrupts or exceptions, or to access protected resources.

## REGISTERS

The S3C4510B CPU core has a total of 37 registers: 31 general-purpose 32-bit registers, and 6 status registers. Not all of these registers are always available. Whether a registers is available to the programmer at any given time depends on the current processor operating state and mode.

### NOTE

When the S3C4510B is operating in ARM state, 16 general registers and one or two status registers can be accessed at any time. In privileged mode, mode-specific banked registers are switched in.

Two register sets, or banks, can also be accessed, depending on the core's current state, the *ARM state register set* and the *THUMB state register set*.

- The ARM state register set contains 16 directly accessible registers: R0-R15. All of these registers, except for R15, are for general-purpose use, and can hold either data or address values. An additional (17th) register, the CPSR (Current Program Status Register), is used to store status information.
- The THUMB state register set is a subset of the ARM state set. You can access 8 general registers, R0-R7, as well as the program counter (PC), a stack pointer register (SP), a link register (LR), and the CPSR. Each privileged mode has a corresponding banked stack pointer, link register, and saved process status register (SPSR).

The THUMB state registers are related to the ARM state registers as follows:

- THUMB state R0-R7 registers and ARM state R0–R7 registers are identical
- THUMB state CPSR and SPSRs and ARM state CPSR and SPSRs are identical
- THUMB state SP, LR, and PC are mapped directly to ARM state registers R13, R14, and R15, respectively

In THUMB state, registers R8-R15 are not part of the standard register set. However, you can access them for assembly language programming and use them for fast temporary storage, if necessary.

## EXCEPTIONS

An *exception* arises when the normal flow of program execution is interrupted, e.g., when processing is diverted to handle an interrupt from a peripheral. The processor state just prior to handling the exception must be preserved so that the program flow can be resumed when the exception routine is completed. Multiple exceptions may arise simultaneously.

To process exceptions, the S3C4510B uses the banked core registers to save the current state. The old PC value and the CPSR contents are copied into the appropriate R14 (LR) and SPSR registers. The PC and mode bits in the CPSR are adjusted to the value corresponding to the type of exception being processed.

The S3C4510B core supports seven types of exceptions. Each exception has a fixed priority and a corresponding privileged processor mode, as shown in Table 1-4.

**Table 1-4. S3C4510B CPU Exceptions**

Exception	Mode on Entry	Priority
Reset	Supervisor mode	1 (highest)
Data abort	Abort mode	2
FIQ	FIQ mode	3
IRQ	IRQ mode	4
Prefetch abort	Abort mode	5
Undefined instruction	Undefined mode	6
SWI	Supervisor mode	6 (lowest)

**SPECIAL REGISTERS**

**Table 1-5. S3C4510B Special Registers**

Group	Registers	Offset	R/W	Description	Reset/Value
System Manager	SYSCFG	0x0000	R/W	System configuration register	0x37FFFF91
	CLKCON	0x3000	R/W	Clock control register	0x00000000
	EXTACON0	0x3008	R/W	External I/O timing register 1	0x00000000
	EXTACON1	0x300C	R/W	External I/O timing register 2	0x00000000
	EXTDBWTH	0x3010	R/W	Data bus width for each memory bank	0x00000000
	ROMCON0	0x3014	R/W	ROM/SRAM/Flash bank 0 control register	0x20000060
	ROMCON1	0x3018	R/W	ROM/SRAM/Flash bank 1 control register	0x00000060
	ROMCON2	0x301C	R/W	ROM/SRAM/Flash bank 2 control register	0x00000060
	ROMCON3	0x3020	R/W	ROM/SRAM/Flash bank 3 control register	0x00000060
	ROMCON4	0x3024	R/W	ROM/SRAM/Flash bank 4 control register	0x00000060
	ROMCON5	0x3028	R/W	ROM/SRAM/Flash bank 5 control register	0x00000060
	DRAMCON0	0x302C	R/W	DRAM bank 0 control register	0x00000000
	DRAMCON1	0x3030	R/W	DRAM bank 1 control register	0x00000000
	DRAMCON2	0x3034	R/W	DRAM bank 2 control register	0x00000000
	DRAMCON3	0x3038	R/W	DRAM bank 3 control register	0x00000000
REFEXTCON	0x303C	R/W	Refresh and external I/O control register	0x000083FD	
Ethernet (BDMA)	BDMATXCON	0x9000	R/W	Buffered DMA receive control register	0x00000000
	BDMARXC ON	0x9004	R/W	Buffered DMA transmit control register	0x00000000
	BDMATXPTR	0x9008	R/W	Transmit frame descriptor start address	0x00000000
	BDMARXPTR	0x900C	R/W	Receive frame descriptor start address	0x00000000
	BDMARXLSZ	0x9010	R/W	Receive frame maximum size	Undefined
	BDMASTAT	0x9014	R/W	Buffered DMA status	0x00000000
	CAM	0x9100– 0x917C	W	CAM content (32 words)	Undefined
	BDMATXBUF	0x9200– 0x92FC	R/W	BDMA Tx buffer (64 words) for test mode addressing	Undefined
BDMARXBUF	0x9800– 0x99FC	R/W	BDMA Rx buffer (64 words) for test mode addressing	Undefined	

Table 1-5. S3C4510B Special Registers (Continued)

Group	Registers	Offset	R/W	Description	Reset/Value
Ethernet (MAC)	MACON	0xA000	R/W	Ethernet MAC control register	0x00000000
	CAMCON	0xA004	R/W	CAM control register	0x00000000
	MACTXCON	0xA008	R/W	MAC transmit control register	0x00000000
	MACTXSTAT	0xA00C	R/W	MAC transmit status register	0x00000000
	MACRXCON	0xA010	R/W	MAC receive control register	0x00000000
	MACRXSTAT	0xA014	R/W	MAC receive status register	0x00000000
	STADATA	0xA018	R/W	Station management data	0x00000000
	STACON	0xA01C	R/W	Station management control and address	0x00006000
	CAMEN	0xA028	R/W	CAM enable register	0x00000000
	EMISSCNT	0xA03C	R/W	Missed error count register	0x00000000
	EPZCNT	0xA040	R	Pause count register	0x00000000
	ERMPZCNT	0xA044	R	Remote pause count register	0x00000000
	ETXSTAT	0x9040	R	Transmit control frame status	0x00000000
HDLC Channel A	HMODE	0x7000	R/W	HDLC mode register	0x00000000
	HCON	0x7004	R/W	HDLC control register	0x00000000
	HSTAT	0x7008	R/W	HDLC status register	0x00010400
	HINTEN	0x700C	R/W	HDLC interrupt enable register	0x00000000
	HTXFIFOC	0x7010	W	TxFIFO frame continue register	–
	HTXFIFOT	0x7014	W	TxFIFO frame terminate register	–
	HRXFIFO	0x7018	R	HDLC Rx FIFO entry register	0x00000000
	HBRGTC	0x701C	R/W	HDLC baud rate generate time constant	0x00000000
	HPRMB	0x7020	R/W	HDLC preamble constant	0x00000000
	HSAR0	0x7024	R/W	HDLC station address 0	0x00000000
	HSAR1	0x7028	R/W	HDLC station address 1	0x00000000
	HSAR2	0x702C	R/W	HDLC station address 2	0x00000000
	HSAR3	0x7030	R/W	HDLC station address 3	0x00000000
	HMASK	0x7034	R/W	HDLC mask register	0x00000000
	DMATxPTR	0x7038	R/W	DMA Tx buffer descriptor pointer	0xFFFFFFFF
	DMARxPTR	0x703C	R/W	DMA Rx buffer descriptor pointer	0xFFFFFFFF
	HMFLR	0x7040	R/W	Maximum frame length register	0xFFFF0000
HRBSR	0x7040	R/W	DMA receive buffer size register	0xFFFF0000	

Table 1-5. S3C4510B Special Registers (Continued)

Group	Registers	Offset	R/W	Description	Reset/Value
HDLC Channel B	HMODE	0x8000	R/W	HDLC mode register	0x00000000
	HCON	0x8004	R/W	HDLC control register	0x00000000
	HSTAT	0x8008	R/W	HDLC status register	0x00010400
	HINTEN	0x800C	R/W	HDLC interrupt enable register	0x00000000
	HTXFIFOC	0x8010	W	TxFIFO frame continue register	–
	HTXFIFOT	0x8014	W	TxFIFO frame terminate register	–
	HRXFIFO	0x8018	R	HDLC RxFIFO entry register	0x00000000
	HBRGTC	0x801C	R/W	HDLC baud rate generate time constant	0x00000000
	HPRMB	0xA020	R/W	HDLC preamble constant	0x00000000
	HSAR0	0x8024	R/W	HDLC station address 0	0x00006000
	HSAR1	0x8028	R/W	HDLC station address 1	0x00000000
	HSAR2	0x802C	R/W	HDLC station address 2	0x00000000
	HSAR3	0x8030	R	HDLC station address 3	0x00000000
	HMASK	0x8034	R	HDLC mask register	0x00000000
	DMATxPTR	0x8038	R	DMA Tx buffer descriptor pointer	0xFFFFFFFF
	DMARxPTR	0x803C	R/W	DMA Rx buffer descriptor pointer	0xFFFFFFFF
	HMFLR	0x8040	R/W	Maximum frame length register	0xFFFF0000
	HRBSR	0x8044	R/W	DMA receive buffer size register	0xFFFF0000
I/O Ports	IOPMOD	0x5000	R/W	I/O port mode register	0x00000000
	IOPCON	0x5004	R/W	I/O port control register	0x00000000
	IOPDATA	0x5008	R/W	Input port data register	Undefined
Interrupt Controller	INTMOD	0x4000	R/W	Interrupt mode register	0x00000000
	INTPND	0x4004	R/W	Interrupt pending register	0x00000000
	INTMSK	0x4008	R/W	Interrupt mask register	0x003FFFFFFF
	INTPRI0	0x400C	R/W	Interrupt priority register 0	0x03020100
	INTPRI1	0x4010	R/W	Interrupt priority register 1	0x07060504
	INTPRI2	0x4014	R/W	Interrupt priority register 2	0x0B0A0908
	INTPRI3	0x4018	R/W	Interrupt priority register 3	0x0F0E0D0C
	INTPRI4	0x401C	R/W	Interrupt priority register 4	0x13121110
	INTPRI5	0x4020	R/W	Interrupt priority register 5	0x00000014
	INTOFFSET	0x4024	R	Interrupt offset address register	0x00000054
	INTOSET_FIQ	0x4030	R	FIQ interrupt offset register	0x00000054
INTOSET_IRQ	0x4034	R	IRQ interrupt offset register	0x00000054	
I <sup>2</sup> C Bus	IICCON	0xF000	R/W	I <sup>2</sup> C bus control status register	0x00000054
	IICBUF	0xF004	R/W	I <sup>2</sup> C bus shift buffer register	Undefined
	IICPS	0xF008	R/W	I <sup>2</sup> C bus prescaler register	0x00000000
	IICCOUNT	0xF00C	R	I <sup>2</sup> C bus prescaler counter register	0x00000000



Table 1-5. S3C4510BC Special Registers (Continued)

Group	Registers	Offset	R/W	Description	Reset/Value
GDMA	GDMACON0	0xB000	R/W	GDMA channel 0 control register	0x00000000
	GDMACON1	0xC000	R/W	GDMA channel 1 control register	0x00000000
	GDMASRC0	0xB004	R/W	GDMA source address register 0	Undefined
	GDMADST0	0xB008	R/W	GDMA destination address register 0	Undefined
	GDMASRC1	0xC004	R/W	GDMA source address register 1	Undefined
	GDMADST1	0xC008	R/W	GDMA destination address register 1	Undefined
	GDMACNT0	0xB00C	R/W	GDMA channel 0 transfer count register	Undefined
	GDMACNT1	0xC00C	R/W	GDMA channel 1 transfer count register	Undefined
UART	ULCON0	0xD000	R/W	UART channel 0 line control register	0x00
	ULCON1	0xE000	R/W	UART channel 1 line control register	0x00
	UCON0	0xD004	R/W	UART channel 0 control register	0x00
	UCON1	0xE004	R/W	UART channel 1 control register	0x00
	USTAT0	0xD008	R	UART channel 0 status register	0xC0
	USTAT1	0xE008	R	UART channel 1 status register	0xC0
	UTXBUF0	0xD00C	W	UART channel 0 transmit holding register	Undefined
	UTXBUF1	0xE00C	W	UART channel 1 transmit holding register	Undefined
	URXBUF0	0xD010	R	UART channel 0 receive buffer register	Undefined
	URXBUF1	0xE010	R	UART channel 1 receive buffer register	Undefined
	UBRDIV0	0xD014	R/W	Baud rate divisor register 0	0x00
	UBRDIV1	0xE014	R/W	Baud rate divisor register 1	0x00
Timers	TMOD	0x6000	R/W	Timer mode register	0x00000000
	TDATA0	0x6004	R/W	Timer 0 data register	0x00000000
	TDATA1	0x6008	R/W	Timer 1 data register	0x00000000
	TCNT0	0x600C	R/W	Timer 0 count register	0xFFFFFFFF
	TCNT1	0x6010	R/W	Timer 1 count register	0xFFFFFFFF

## NOTES

# 2 PROGRAMMER'S MODEL

## OVERVIEW

S3C4510B was developed using the advanced ARM7TDMI core designed by advanced RISC machines, Ltd.

Processor Operating States

From the programmer's point of view, the ARM7TDMI can be in one of two states:

- ARM state which executes 32-bit, word-aligned ARM instructions.
- THUMB state which operates with 16-bit, half-word-aligned THUMB instructions. In this state, the PC uses bit 1 to select between alternate half-words.

### NOTE

Transition between these two states does not affect the processor mode or the contents of the registers.

## SWITCHING STATE

### Entering THUMB State

Entry into THUMB state can be achieved by executing a BX instruction with the state bit (bit 0) set in the operand register.

Transition to THUMB state will also occur automatically on return from an exception (IRQ, FIQ, UNDEF, ABORT, SWI etc.), if the exception was entered with the processor in THUMB state.

### Entering ARM State

Entry into ARM state happens:

1. On execution of the BX instruction with the state bit clear in the operand register.
2. On the processor taking an exception (IRQ, FIQ, RESET, UNDEF, ABORT, SWI etc.). In this case, the PC is placed in the exception mode's link register, and execution commences at the exception's vector address.

## MEMORY FORMATS

ARM7TDMI views memory as a linear collection of bytes numbered upwards from zero. Bytes 0 to 3 hold the first stored word, bytes 4 to 7 the second and so on. ARM7TDMI can treat words in memory as being stored either in Big-Endian or Little-Endian format.

**BIG-ENDIAN FORMAT**

In Big-Endian format, the most significant byte of a word is stored at the lowest numbered byte and the least significant byte at the highest numbered byte. Byte 0 of the memory system is therefore connected to data lines 31 through 24.

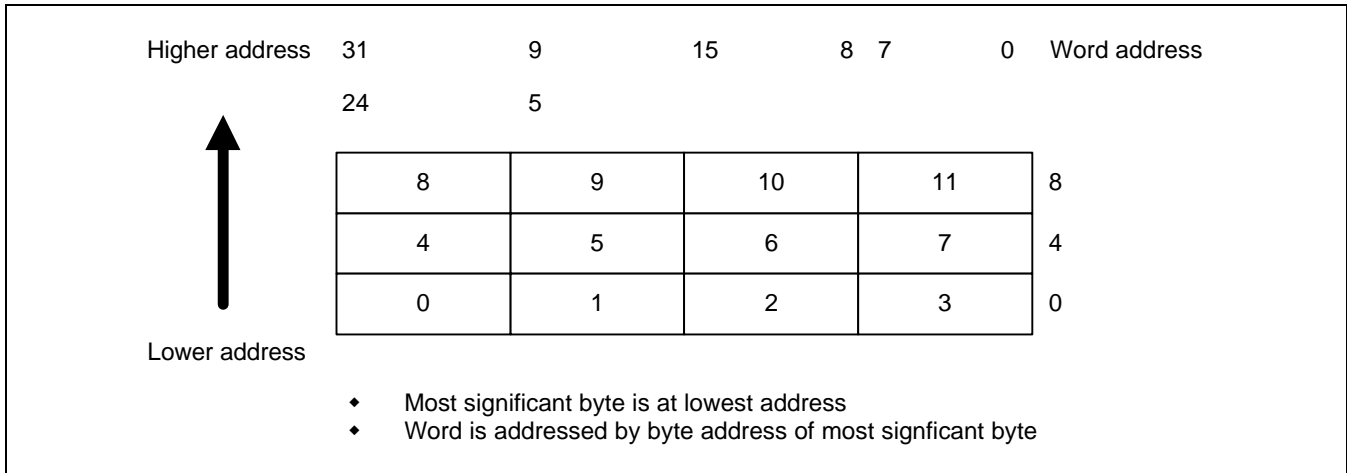

**Figure 2-1. Big-Endian Addresses of Bytes within Words**

**NOTE**

The data locations in the external memory are different with Figure 2-1 in the S3C4620. Please refer to the chapter 4, system manager.

**LITTLE-ENDIAN FORMAT**

In Little-Endian format, the lowest numbered byte in a word is considered the word's least significant byte, and the highest numbered byte the most significant. Byte 0 of the memory system is therefore connected to data lines 7 through 0.

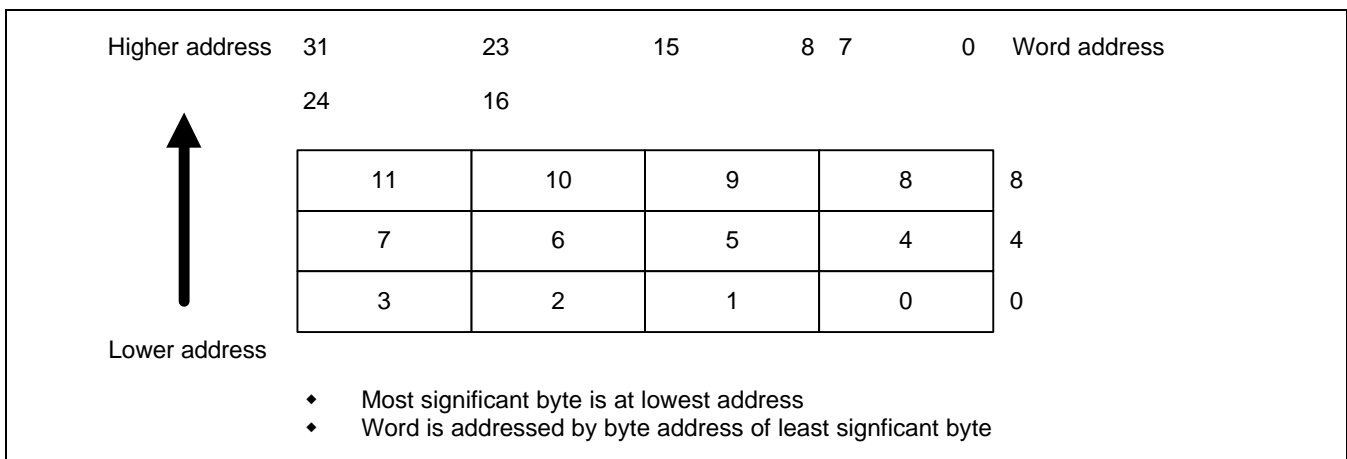

**Figure 2-2. Little-Endian Addresses of Bytes Words**

## INSTRUCTION LENGTH

Instructions are either 32 bits long (in ARM state) or 16 bits long (in THUMB state).

### Data Types

ARM7TDMI supports byte (8-bit), half-word (16-bit) and word (32-bit) data types. Words must be aligned to four-byte boundaries and half words to two-byte boundaries.

## OPERATING MODES

ARM7TDMI supports seven modes of operation:

- User (usr):           The normal ARM program execution state
- FIQ (fiq):           Designed to support a data transfer or channel process
- IRQ (irq):           Used for general-purpose interrupt handling
- Supervisor (svc):   Protected mode for the operating system
- Abort mode (abt):   Entered after a data or instruction prefetch abort
- System (sys):       A privileged user mode for the operating system
- Undefined (und):    Entered when an undefined instruction is executed

Mode changes may be made under software control, or may be brought about by external interrupts or exception processing. Most application programs will execute in User mode. The non-user modes known as privileged modes are entered in order to service interrupts or exceptions, or to access protected resources.

## REGISTERS

ARM7TDMI has a total of 37 registers-31 general-purpose 32-bit registers and six status registers - but these cannot all be seen at once. The processor state and operating mode dictate which registers are available to the programmer.

### The ARM State Register Set

In ARM state, 16 general registers and one or two status registers are visible at any one time. In privileged (non-User) modes, mode-specific banked registers are switched in. Figure 2-3 shows which registers are available in each mode: the banked registers are marked with a shaded triangle.

The ARM state register set contains 16 directly accessible registers: R0 to R15. All of these except R15 are general-purpose, and may be used to hold either data or address values. In addition to these, there is a seventeenth register used to store status information.

Register 14	is used as the subroutine link register. This receives a copy of R15 when a branch and link (BL) instruction is executed. At all other times it may be treated as a general-purpose register. The corresponding banked registers R14_svc, R14_irq, R14_fiq, R14_abt and R14_und are similarly used to hold the return values of R15 when interrupts and exceptions arise, or when branch and link instructions are executed within interrupt or exception routines.
Register 15	holds the Program Counter (PC). In ARM state, bits [1:0] of R15 are zero and bits [31:2] contain the PC. In THUMB state, bit [0] is zero and bits [31:1] contain the PC.
Register 16	is the CPSR (Current Program Status Register). This contains condition code flags and the current mode bits.

FIQ mode has seven banked registers mapped to R8-14 (R8\_fiq-R14\_fiq). In ARM state, many FIQ handlers do not need to save any registers. User, IRQ, Supervisor, Abort and Undefined each have two banked registers mapped to R13 and R14, allowing each of these modes to have a private stack pointer and link registers.

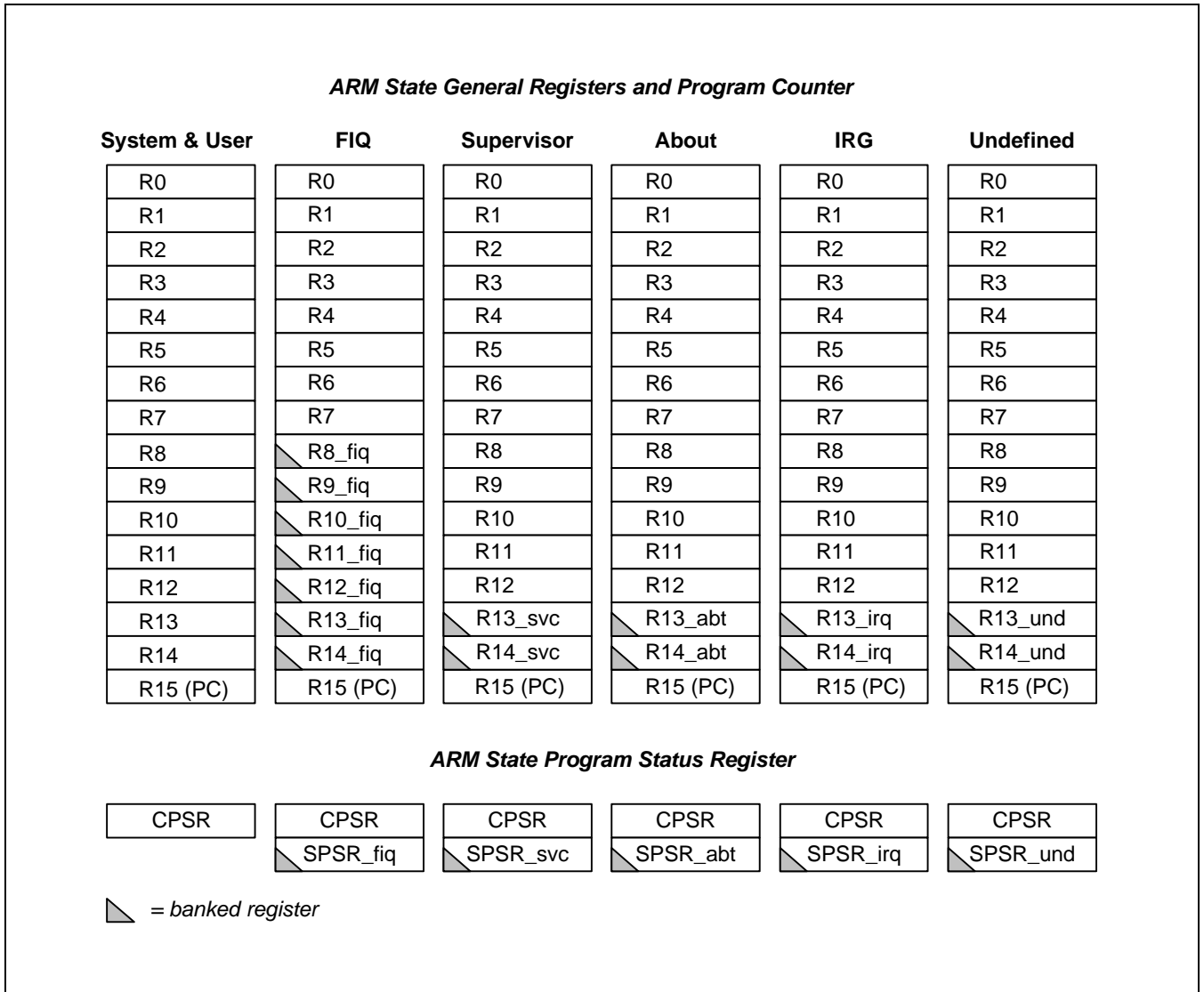
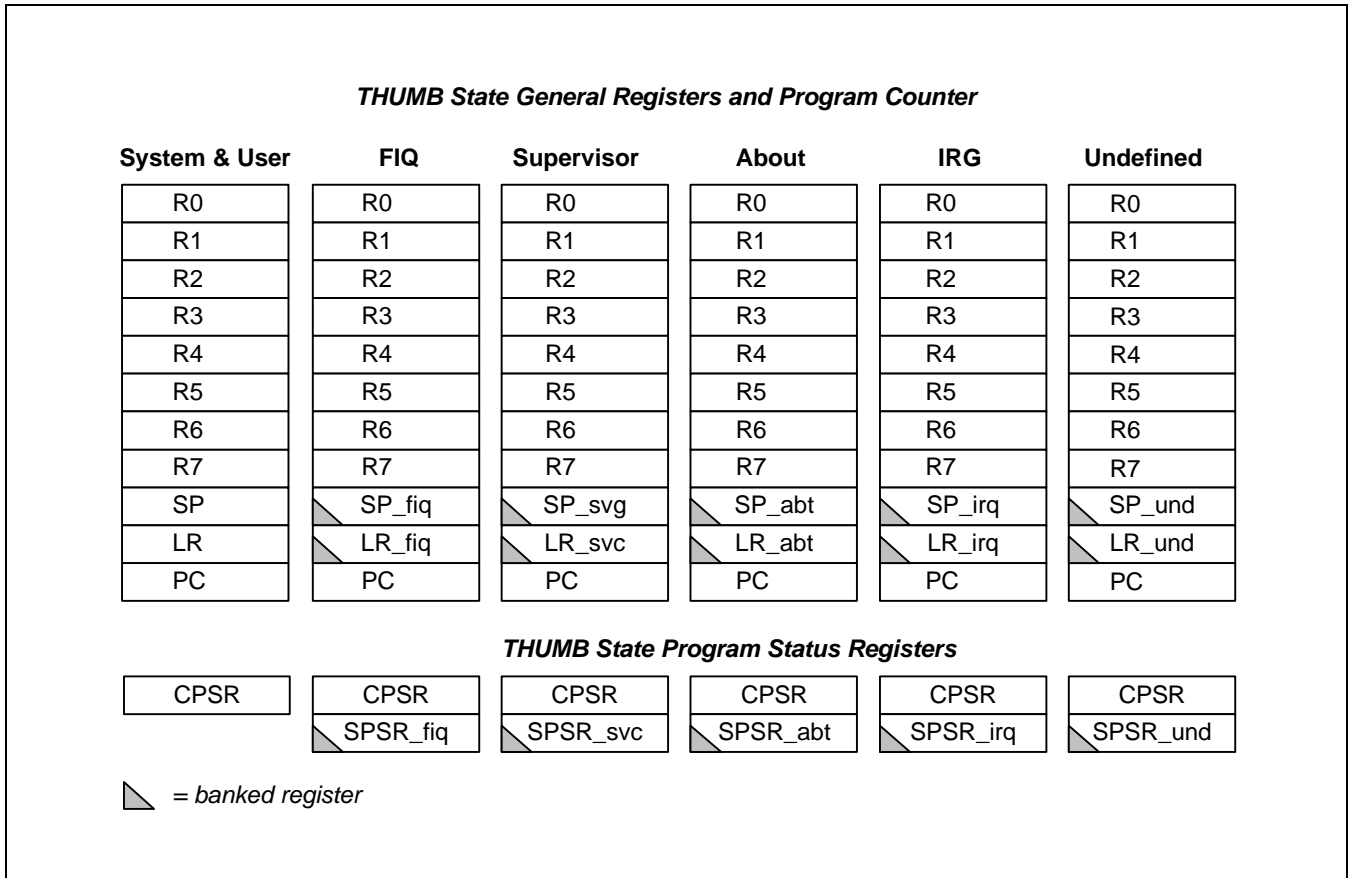

Figure 2-3. Register Organization in ARM State

**The THUMB State Register Set**

The THUMB state register set is a subset of the ARM state set. The programmer has direct access to eight general registers, R0–R7, as well as the Program Counter (PC), a stack pointer register (SP), a link register (LR), and the CPSR. There are banked stack pointers, link registers and Saved Process Status Registers (SPSRs) for each privileged mode. This is shown in Figure 2-4.



**Figure 2-4. Register Organization in THUMB State**



### The Relationship between ARM and THUMB State Registers

The THUMB state registers relate to the ARM state registers in the following way:

- THUMB state R0–R7 and ARM state R0–R7 are identical
- THUMB state CPSR and SPSRs and ARM state CPSR and SPSRs are identical
- THUMB state SP maps onto ARM state R13
- THUMB state LR maps onto ARM state R14
- The THUMB state program counter maps onto the ARM state program counter (R15)

This relationship is shown in Figure 2-5.

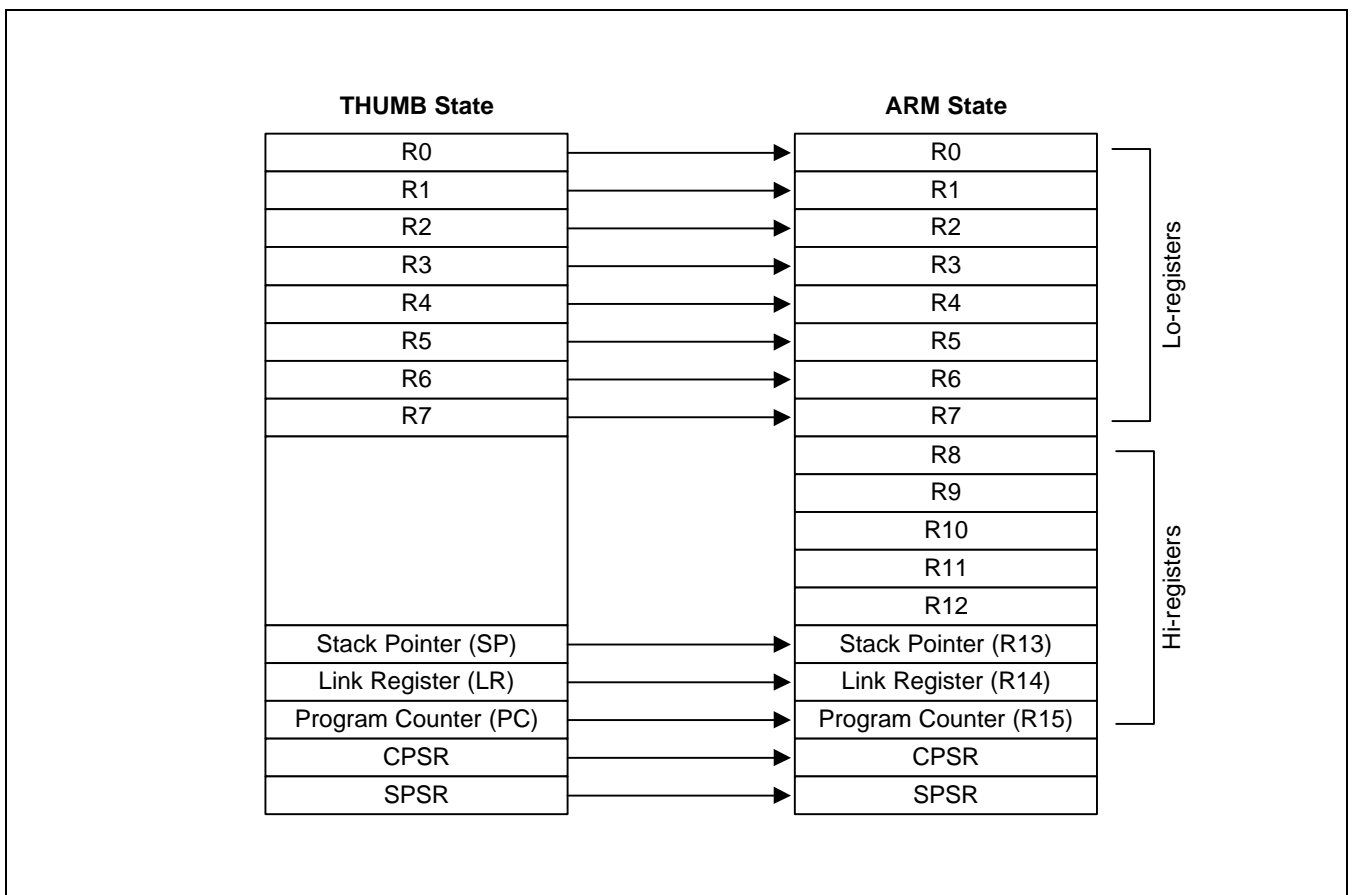

Figure 2-5. Mapping of THUMB State Registers onto ARM State Registers

**Accessing Hi-Registers in THUMB State**

In THUMB state, registers R8–R15 (the Hi registers) are not part of the standard register set. However, the assembly language programmer has limited access to them, and can use them for fast temporary storage.

A value may be transferred from a register in the range R0–R7 (a Lo register) to a Hi register, and from a Hi register to a Lo register, using special variants of the MOV instruction. Hi register values can also be compared against or added to Lo register values with the CMP and ADD instructions. For more information, refer to Figure 3-34.

**THE PROGRAM STATUS REGISTERS**

The ARM7TDMI contains a Current Program Status Register (CPSR), plus five Saved Program Status Registers (SPSRs) for use by exception handlers. These register's functions are:

- Hold information about the most recently performed ALU operation
- Control the enabling and disabling of interrupts
- Set the processor operating mode

The arrangement of bits is shown in Figure 2-6.

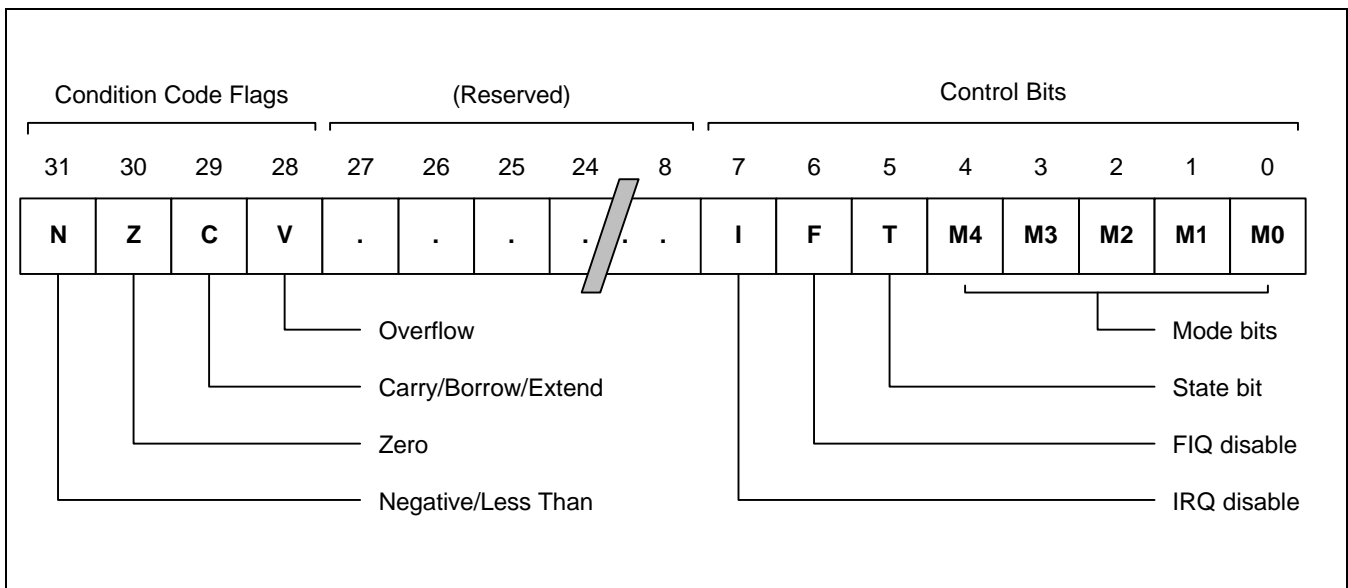

**Figure 2-6. Program Status Register Format**

### The Condition Code Flags

The N, Z, C and V bits are the condition code flags. These may be changed as a result of arithmetic and logical operations, and may be tested to determine whether an instruction should be executed.

In ARM state, all instructions may be executed conditionally: see Table 3-2 for details.

In THUMB state, only the branch instruction is capable of conditional execution: see Figure 3-46 for details.

### The Control Bits

The bottom 8 bits of a PSR (incorporating I, F, T and M[4:0]) are known collectively as the control bits. These will change when an exception arises. If the processor is operating in a privileged mode, they can also be manipulated by software.

The T bit	This reflects the operating state. When this bit is set, the processor is executing in THUMB state, otherwise it is executing in ARM state. This is reflected on the TBIT external signal.  Note that the software must never change the state of the TBIT in the CPSR. If this happens, the processor will enter an unpredictable state.
Interrupt disable bits	The I and F bits are the interrupt disable bits. When set, these disable the IRQ and FIQ interrupts respectively.
The mode bits	The M4, M3, M2, M1 and M0 bits (M[4:0]) are the mode bits. These determine the processor's operating mode, as shown in Table 2-1. Not all combinations of the mode bits define a valid processor mode. Only those explicitly described shall be used. The user should be aware that if any illegal value is programmed into the mode bits, M[4:0], then the processor will enter an unrecoverable state. If this occurs, reset should be applied.

Table 2-1. PSR Mode. Bit Values

M[4:0]	Mode	Visible THUMB State Registers	Visible ARM State Registers
10000	User	R7..R0, LR, SP PC, CPSR	R14..R0, PC, CPSR
10001	FIQ	R7..R0, LR_fiq, SP_fiq PC, CPSR, SPSR_fiq	R7..R0, R14_fiq..R8_fiq, PC, CPSR, SPSR_fiq
10010	IRQ	R7..R0, LR_irq, SP_irq PC, CPSR, SPSR_irq	R12..R0, R14_irq..R13_irq, PC, CPSR, SPSR_irq
10011	Supervisor	R7..R0, LR_svc, SP_svc, PC, CPSR, SPSR_svc	R12..R0, R14_svc..R13_svc, PC, CPSR, SPSR_svc
10111	Abort	R7..R0, LR_abt, SP_abt, PC, CPSR, SPSR_abt	R12..R0, R14_abt..R13_abt, PC, CPSR, SPSR_abt
11011	Undefined	R7..R0 LR_und, SP_und, PC, CPSR, SPSR_und	R12..R0, R14_und..R13_und, PC, CPSR
11111	System	R7..R0, LR, SP PC, CPSR	R14..R0, PC, CPSR

## Reserved bits

The remaining bits in the PSRs are reserved. When changing a PSR's flag or control bits, you must ensure that these unused bits are not altered. Also, your program should not rely on them containing specific values, since in future processors they may read as one or zero.

## EXCEPTIONS

Exceptions arise whenever the normal flow of a program has to be halted temporarily, for example to service an interrupt from a peripheral. Before an exception can be handled, the current processor state must be preserved so that the original program can resume when the handler routine has finished.

It is possible for several exceptions to arise at the same time. If this happens, they are dealt with in a fixed order. See Exception Priorities on page 2-14.

### Action on Entering an Exception

When handling an exception, the ARM7TDMI:

1. Preserves the address of the next instruction in the appropriate Link Register. If the exception has been entered from ARM state, then the address of the next instruction is copied into the Link Register (that is, current PC + 4 or PC + 8 depending on the exception. See Table 2-2 on for details). If the exception has been entered from THUMB state, then the value written into the Link Register is the current PC offset by a value such that the program resumes from the correct place on return from the exception. This means that the exception handler need not determine which state the exception was entered from. For example, in the case of SWI, MOVS PC, R14\_svc will always return to the next instruction regardless of whether the SWI was executed in ARM or THUMB state.
2. Copies the CPSR into the appropriate SPSR
3. Forces the CPSR mode bits to a value which depends on the exception
4. Forces the PC to fetch the next instruction from the relevant exception vector

It may also set the interrupt disable flags to prevent otherwise unmanageable nesting of exceptions.

If the processor is in THUMB state when an exception occurs, it will automatically switch into ARM state when the PC is loaded with the exception vector address.

### Action on Leaving an Exception

On completion, the exception handler:

1. Moves the Link Register, minus an offset where appropriate, to the PC. (The offset will vary depending on the type of exception.)
2. Copies the SPSR back to the CPSR
3. Clears the interrupt disable flags, if they were set on entry

### NOTE

An explicit switch back to THUMB state is never needed, since restoring the CPSR from the SPSR automatically sets the T bit to the value it held immediately prior to the exception.

### Exception Entry/Exit Summary

Table 2-2 summarizes the PC value preserved in the relevant R14 on exception entry, and the recommended instruction for exiting the exception handler.

**Table 2-2. Exception Entry/Exit**

	Return Instruction	Previous State		Notes
		ARM R14_x	THUMB R14_x	
BL	MOV PC, R14	PC + 4	PC + 2	1
SWI	MOVS PC, R14_svc	PC + 4	PC + 2	1
UDEF	MOVS PC, R14_und	PC + 4	PC + 2	1
FIQ	SUBS PC, R14_fiq, #4	PC + 4	PC + 4	2
IRQ	SUBS PC, R14_irq, #4	PC + 4	PC + 4	2
PABT	SUBS PC, R14_abt, #4	PC + 4	PC + 4	1
DABT	SUBS PC, R14_abt, #8	PC + 8	PC + 8	3
RESET	NA	–	–	4

#### NOTES:

1. Where PC is the address of the BL/SWI/Undefined Instruction fetch which had the prefetch abort.
2. Where PC is the address of the instruction which did not get executed since the FIQ or IRQ took priority.
3. Where PC is the address of the Load or Store instruction which generated the data abort.
4. The value saved in R14\_svc upon reset is unpredictable.

#### FIQ

The FIQ (Fast Interrupt Request) exception is designed to support a data transfer or channel process, and in ARM state has sufficient private registers to remove the need for register saving (thus minimizing the overhead of context switching).

FIQ is externally generated by taking the nFIQ input LOW. This input can except either synchronous or asynchronous transitions, depending on the state of the ISYNC input signal. When ISYNC is LOW, nFIQ and nIRQ are considered asynchronous, and a cycle delay for synchronization is incurred before the interrupt can affect the processor flow.

Irrespective of whether the exception was entered from ARM or Thumb state, a FIQ handler should leave the interrupt by executing

```
SUBS    PC,R14_fiq,#4
```

FIQ may be disabled by setting the CPSR's F flag (but note that this is not possible from User mode). If the F flag is clear, ARM7TDMI checks for a LOW level on the output of the FIQ synchroniser at the end of each instruction.

**IRQ**

The IRQ (Interrupt Request) exception is a normal interrupt caused by a LOW level on the nIRQ input. IRQ has a lower priority than FIQ and is masked out when a FIQ sequence is entered. It may be disabled at any time by setting the I bit in the CPSR, though this can only be done from a privileged (non-User) mode.

Irrespective of whether the exception was entered from ARM or Thumb state, an IRQ handler should return from the interrupt by executing

```
SUBS    PC,R14_irq,#4
```

**Abort**

An abort indicates that the current memory access cannot be completed. It can be signalled by the external ABORT input. ARM7TDMI checks for the abort exception during memory access cycles.

There are two types of abort:

- Prefetch abort: occurs during an instruction prefetch.
- Data abort: occurs during a data access.

If a prefetch abort occurs, the prefetched instruction is marked as invalid, but the exception will not be taken until the instruction reaches the head of the pipeline. If the instruction is not executed - for example because a branch occurs while it is in the pipeline - the abort does not take place.

If a data abort occurs, the action taken depends on the instruction type:

- Single data transfer instructions (LDR, STR) write back modified base registers: the Abort handler must be aware of this.
- The swap instruction (SWP) is aborted as though it had not been executed.
- Block data transfer instructions (LDM, STM) complete. If write-back is set, the base is updated. If the instruction would have overwritten the base with data (ie it has the base in the transfer list), the overwriting is prevented. All register overwriting is prevented after an abort is indicated, which means in particular that R15 (always the last register to be transferred) is preserved in an aborted LDM instruction.

The abort mechanism allows the implementation of a demand paged virtual memory system. In such a system the processor is allowed to generate arbitrary addresses. When the data at an address is unavailable, the Memory Management Unit (MMU) signals an abort. The abort handler must then work out the cause of the abort, make the requested data available, and retry the aborted instruction. The application program needs no knowledge of the amount of memory available to it, nor is its state in any way affected by the abort.

After fixing the reason for the abort, the handler should execute the following irrespective of the state (ARM or Thumb):

```
SUBS    PC,R14_abt,#4      ; for a prefetch abort, or
SUBS    PC,R14_abt,#8      ; for a data abort
```

This restores both the PC and the CPSR, and retries the aborted instruction.

### Software Interrupt

The software interrupt instruction (SWI) is used for entering Supervisor mode, usually to request a particular supervisor function. A SWI handler should return by executing the following irrespective of the state (ARM or Thumb):

```
MOV    PC,R14_svc
```

This restores the PC and CPSR, and returns to the instruction following the SWI.

#### NOTE

nFIQ, nIRQ, ISYNC, LOCK, BIGEND, and ABORT pins exist only in the ARM7TDMI CPU core.

### Undefined Instruction

When ARM7TDMI comes across an instruction which it cannot handle, it takes the undefined instruction trap. This mechanism may be used to extend either the THUMB or ARM instruction set by software emulation.

After emulating the failed instruction, the trap handler should execute the following irrespective of the state (ARM or Thumb):

```
MOVS  PC,R14_und
```

This restores the CPSR and returns to the instruction following the undefined instruction.

### Exception Vectors

The following table shows the exception vector addresses.

**Table 2-3. Exception Vectors**

Address	Exception	Mode in Entry
0x00000000	Reset	Supervisor
0x00000004	Undefined instruction	Undefined
0x00000008	Software Interrupt	Supervisor
0x0000000C	Abort (prefetch)	Abort
0x00000010	Abort (data)	Abort
0x00000014	Reserved	Reserved
0x00000018	IRQ	IRQ
0x0000001C	FIQ	FIQ



### Exception Priorities

When multiple exceptions arise at the same time, a fixed priority system determines the order in which they are handled:

Highest priority:

1. Reset
2. Data abort
3. FIQ
4. IRQ
5. Prefetch abort

Lowest priority:

6. Undefined Instruction, Software interrupt.

### Not All Exceptions Can Occur at Once:

Undefined Instruction and Software Interrupt are mutually exclusive, since they each correspond to particular (non-overlapping) decoding of the current instruction.

If a data abort occurs at the same time as a FIQ, and FIQs are enabled (ie the CPSR's F flag is clear), ARM7TDMI enters the data abort handler and then immediately proceeds to the FIQ vector. A normal return from FIQ will cause the data abort handler to resume execution. Placing data abort at a higher priority than FIQ is necessary to ensure that the transfer error does not escape detection. The time for this exception entry should be added to worst-case FIQ latency calculations.

### Interrupt Latencies

The worst case latency for FIQ, assuming that it is enabled, consists of the longest time the request can take to pass through the synchroniser ( $T_{syncmax}$  if asynchronous), plus the time for the longest instruction to complete ( $T_{ldm}$ , the longest instruction is an LDM which loads all the registers including the PC), plus the time for the data abort entry ( $T_{exc}$ ), plus the time for FIQ entry ( $T_{fiq}$ ). At the end of this time ARM7TDMI will be executing the instruction at 0x1C.

$T_{syncmax}$  is 3 processor cycles,  $T_{ldm}$  is 20 cycles,  $T_{exc}$  is 3 cycles, and  $T_{fiq}$  is 2 cycles. The total time is therefore 28 processor cycles. This is just over 1.4 microseconds in a system which uses a continuous 20 MHz processor clock. The maximum IRQ latency calculation is similar, but must allow for the fact that FIQ has higher priority and could delay entry into the IRQ handling routine for an arbitrary length of time. The minimum latency for FIQ or IRQ consists of the shortest time the request can take through the synchroniser ( $T_{syncmin}$ ) plus  $T_{fiq}$ . This is 4 processor cycles.

### Reset

When the nRESET signal goes LOW, ARM7TDMI abandons the executing instruction and then continues to fetch instructions from incrementing word addresses.

When nRESET goes HIGH again, ARM7TDMI:

1. Overwrites R14\_svc and SPSR\_svc by copying the current values of the PC and CPSR into them. The value of the saved PC and SPSR is not defined.
2. Forces M[4:0] to 10011 (Supervisor mode), sets the I and F bits in the CPSR, and clears the CPSR's T bit.
3. Forces the PC to fetch the next instruction from address 0x00.
4. Execution resumes in ARM state.

# 3 INSTRUCTION SET

## INSTRUCTION SET SUMMARY

This chapter describes the ARM instruction set and the THUMB instruction set in the ARM7TDMI core.

### FORMAT SUMMARY

The ARM instruction set formats are shown below.

31	30	29	28	27	26	25	24	23	22	21	20	19	18	17	16	15	14	13	12	11	10	9	8	7	6	5	4	3	2	1	0
Cond	0	0	1	Opcode				S	Rn				Rd				Operand2								Data processing/ PSR Transfer						
Cond	0	0	0	0	0	0	0	A	S	Rd				Rn				Rs		1	0	0	1	Rm				Multiply			
Cond	0	0	0	0	0	1	U	A	S	RdHi				RnLo				Rn		1	0	0	1	Rm				Multiply Long			
Cond	0	0	0	1	0	B	0	0	Rn				Rd				0	0	0	0	1	0	0	1	Rm				Single data swap		
Cond	0	0	0	1	0	0	1	0	1	1	1	1	1	1	1	1	1	1	1	1	1	0	0	0	1	Rn				Branch and exchange	
Cond	0	0	0	P	U	0	W	L	Rn				Rd				0	0	0	0	1	S	H	1	Rm				Halfword data transfer: register offset		
Cond	0	0	0	P	U	1	W	L	Rn				Rd				Offset		1	S	H	1	Offset				Halfword data transfer: immediate offset				
Cond	0	1	1	P	U	B	W	L	Rn				Rd				Offset								Single data transfer						
Cond	0	1	1													1					Undefined										
Cond	1	0	0	P	U	S	W	L	Rn				Register List												Block data transfer						
Cond	1	0	1	L	Offset												Branch														
Cond	1	1	0	P	U	N	W	L	Rn				CRd				CP#		Offset				Coprocessor data transfer								
Cond	1	1	1	0	CP Opc				CRn				CRd				CP#		CP#		0	CRm				Coprocessor data Operation					
Cond	1	1	1	0	CP Opc				CRn				Rd				CP#		CP#		1	CRm				Coprocessor register Transfer					
Cond	1	1	1	1	Ignored by processor												Software Interrupt														
31	30	29	28	27	26	25	24	23	22	21	20	19	18	17	16	15	14	13	12	11	10	9	8	7	6	5	4	3	2	1	0

Figure 3-1. ARM Instruction Set Format

**NOTE**

Some instruction codes are not defined but do not cause the Undefined instruction trap to be taken, for instance a Multiply instruction with bit 6 changed to a 1. These instructions should not be used, as their action may change in future ARM implementations.

## INSTRUCTION SUMMARY

Table 3-1. The ARM Instruction Set

Mnemonic	Instruction	Action
ADC	Add with carry	Rd: = Rn + Op2 + Carry
ADD	Add	Rd: = Rn + Op2
AND	AND	Rd: = Rn AND Op2
B	Branch	R15: = address
BIC	Bit clear	Rd: = Rn AND NOT Op2
BL	Branch with link	R14: = R15, R15: = address
BX	Branch and exchange	R15: = Rn, T bit: = Rn[0]
CDP	Coprocessor data processing	(coprocessor-specific)
CMN	Compare negative	CPSR flags: = Rn + Op2
CMP	Compare	CPSR flags: = Rn - Op2
EOR	Exclusive OR	Rd: = (Rn AND NOT Op2) OR (op2 AND NOT Rn)
LDC	Load coprocessor from memory	Coprocessor load
LDM	Load multiple registers	Stack manipulation (Pop)
LDR	Load register from memory	Rd: = (address)
MCR	Move CPU register to coprocessor register	cRn: = rRn {<op>cRm}
MLA	Multiply accumulate	Rd: = (Rm * Rs) + Rn
MOV	Move register or constant	Rd: = Op2
MRC	Move from coprocessor register to CPU register	Rn: = cRn {<op>cRm}
MRS	Move PSR status/flags to register	Rn: = PSR
MSR	Move register to PSR status/flags	PSR: = Rm
MUL	Multiply	Rd: = Rm * Rs
MVN	Move negative register	Rd: = 0xFFFFFFFF EOR Op2

Table 3-1. The ARM Instruction Set (Continued)

Mnemonic	Instruction	Action
ORR	OR	Rd: = Rn OR Op2
RSB	Reverse subtract	Rd: = Op2 - Rn
RSC	Reverse subtract with carry	Rd: = Op2 - Rn-1 + Carry
SBC	Subtract with carry	Rd: = Rn - Op2-1 + Carry
STC	Store coprocessor register to memory	Address: = CRn
STM	Store multiple	Stack manipulation (push)
STR	Store register to memory	<address>: = Rd
SUB	Subtract	Rd: = Rn - Op2
SWI	Software Interrupt	OS call
SWP	Swap register with memory	Rd: = [Rn], [Rn] := Rm
TEQ	Test bit-wise equality	CPSR flags: = Rn EOR Op2
TST	Test bits	CPSR flags: = Rn AND Op2

## THE CONDITION FIELD

In ARM state, all instructions are conditionally executed according to the state of the CPSR condition codes and the instruction's condition field. This field (bits 31:28) determines the circumstances under which an instruction is to be executed. If the state of the C, N, Z and V flags fulfils the conditions encoded by the field, the instruction is executed, otherwise it is ignored.

There are sixteen possible conditions, each represented by a two-character suffix that can be appended to the instruction's mnemonic. For example, a branch (B in assembly language) becomes BEQ for "Branch if "Equal", which means the branch will only be taken if the Z flag is set.

In practice, fifteen different conditions may be used: these are listed in Table 3-2. The sixteenth (1111) is reserved, and must not be used.

In the absence of a suffix, the condition field of most instructions is set to "Always" (suffix AL). This means the instruction will always be executed regardless of the CPSR condition codes.

**Table 3-2. Condition Code Summary**

Code	Suffix	Flags	Meaning
0000	EQ	Z set	Equal
0001	NE	Z clear	Not equal
0010	CS	C set	Unsigned higher or same
0011	CC	C clear	Unsigned lower
0100	MI	N set	Negative
0101	PL	N clear	Positive or zero
0110	VS	V set	Overflow
0111	VC	V clear	No overflow
1000	HI	C set and Z clear	Unsigned higher
1001	LS	C clear or Z set	Unsigned lower or same
1010	GE	N equals V	Greater or equal
1011	LT	N not equal to V	Less than
1100	GT	Z clear AND (N equals V)	Greater than
1101	LE	Z set OR (N not equal to V)	Less than or equal
1110	AL	(Ignored)	Always

## BRANCH AND EXCHANGE (BX)

This instruction is only executed if the condition is true. The various conditions are defined in Table 3-2.

This instruction performs a branch by copying the contents of a general register, Rn, into the program counter, PC. The branch causes a pipeline flush and refill from the address specified by Rn. This instruction also permits the instruction set to be exchanged. When the instruction is executed, the value of Rn[0] determines whether the instruction stream will be decoded as ARM or THUMB instructions.

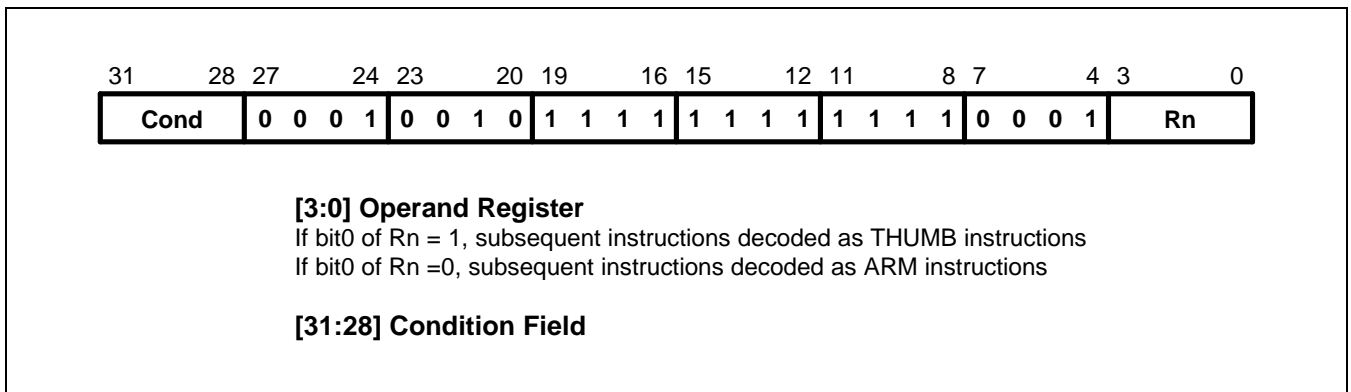

Figure 3-2. Branch and Exchange Instructions

## INSTRUCTION CYCLE TIMES

The BX instruction takes  $2S + 1N$  cycles to execute, where S and N are defined as sequential (S-cycle) and non-sequential (N-cycle), respectively.

## ASSEMBLER SYNTAX

BX - branch and exchange.

BX {cond} Rn

{cond} Two character condition mnemonic. See Table 3-2.

Rn is an expression evaluating to a valid register number.

## USING R15 AS AN OPERAND

If R15 is used as an operand, the behaviour is undefined.

**Examples**

```
ADR      R0, Into_THUMB + 1 ; Generate branch target address
; and set bit 0 high - hence
; arrive in THUMB state.
BX       R0 ; Branch and change to THUMB
; state.
CODE16   ; Assemble subsequent code as
Into_THUMB ; THUMB instructions
.
.
.
ADR R5, Back_to_ARM ; Generate branch target to word aligned address
; - hence bit 0 is low and so change back to ARM state.
BX R5 ; Branch and change back to ARM state.
.
.
.
ALIGN ; Word align
CODE32 ; Assemble subsequent code as ARM instructions
Back_to_ARM
```



## BRANCH AND BRANCH WITH LINK (B, BL)

The instruction is only executed if the condition is true. The various conditions are defined Table 3-2. The instruction encoding is shown in Figure 3-3, below.

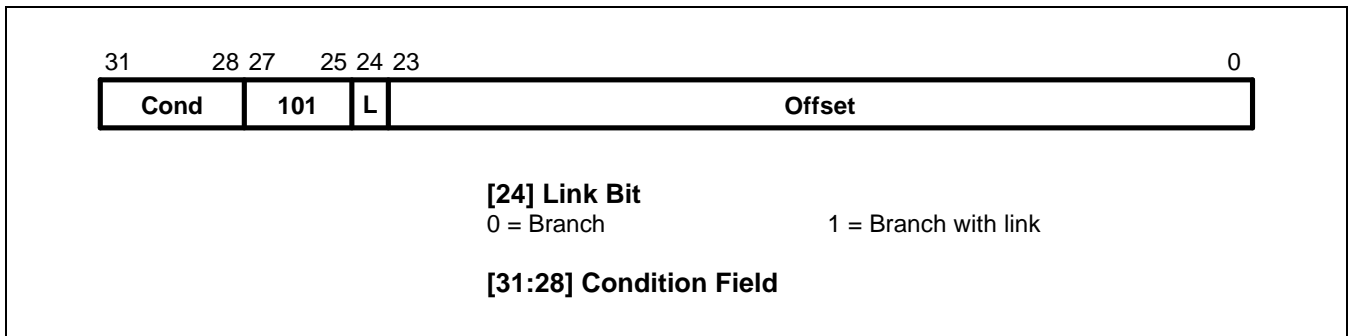

**Figure 3-3. Branch Instructions**

Branch instructions contain a signed 2's complement 24 bit offset. This is shifted left two bits, sign extended to 32 bits, and added to the PC. The instruction can therefore specify a branch of +/- 32Mbytes. The branch offset must take account of the pre-fetch operation, which causes the PC to be 2 words (8 bytes) ahead of the current instruction.

### THE LINK BIT

Branch with Link (BL) writes the old PC into the link register (R14) of the current bank. The PC value written into R14 is adjusted to allow for the pre-fetch, and contains the address of the instruction following the branch and link instruction. Note that the CPSR is not saved with the PC and R14[1:0] are always cleared.

To return from a routine called by branch with link use MOV PC,R14 if the link register is still valid or LDM Rn!,{..PC} if the link register has been saved onto a stack pointed to by Rn.

### INSTRUCTION CYCLE TIMES

Branch and branch with link instructions take  $2S + 1N$  incremental cycles, where S and N are defined as sequential (S-cycle) and internal (I-cycle).

**ASSEMBLER SYNTAX**

Items in {} are optional. Items in < > must be present.

B{L}{cond} <expression>

{L} Used to request the branch with link form of the instruction. If absent, R14 will not be affected by the instruction.

{cond} A two-character mnemonic as shown in Table 3-2. If absent then AL (Always) will be used.

<expression> The destination. The assembler calculates the offset.

**Examples**

here	BAL	here	; Assembles to 0xEAFFFFF0 (note effect of PC offset).
	B	there	; Always condition used as default.
	CMP	R1,#0	; Compare R1 with zero and branch to fred
			; if R1 was zero, otherwise continue.
	BEQ	fred	; Continue to next instruction.
	BL	sub+ROM	; Call subroutine at computed address.
	ADDS	R1,#1	; Add 1 to register 1, setting CPSR flags
			; on the result then call subroutine if
	BLCC	sub	; the C flag is clear, which will be the
			; case unless R1 held 0xFFFFFFFF.

### DATA PROCESSING

The data processing instruction is only executed if the condition is true. The conditions are defined in Table 3-2. The instruction encoding is shown in Figure 3-4.

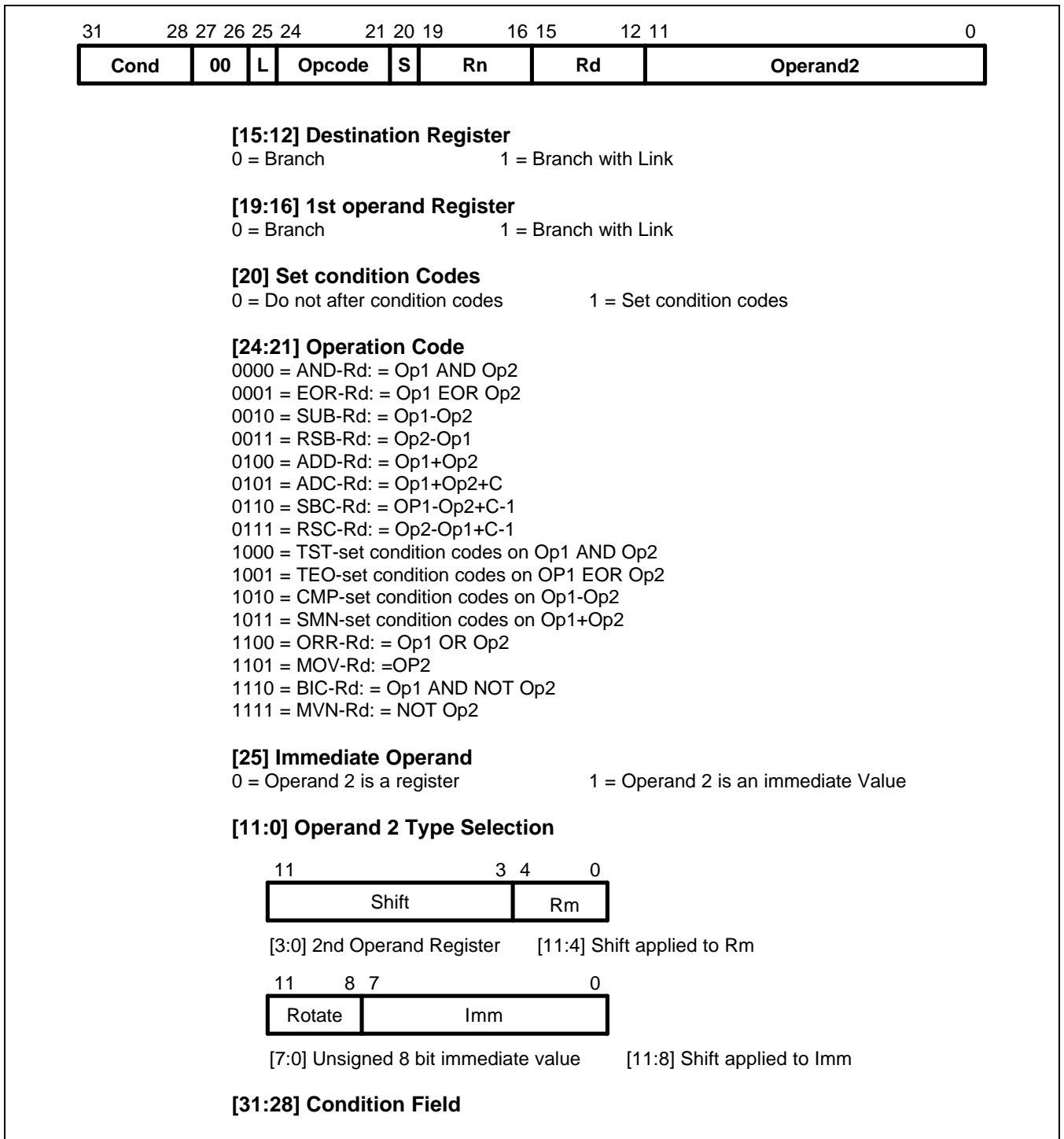

Figure 3-4. Data Processing Instructions

The instruction produces a result by performing a specified arithmetic or logical operation on one or two operands. The first operand is always a register (Rn).

The second operand may be a shifted register (Rm) or a rotated 8 bit immediate value (Imm) according to the value of the I bit in the instruction. The condition codes in the CPSR may be preserved or updated as a result of this instruction, according to the value of the S bit in the instruction.

Certain operations (TST, TEQ, CMP, CMN) do not write the result to Rd. They are used only to perform tests and to set the condition codes on the result and always have the S bit set. The instructions and their effects are listed in Table 3-3.

## CPSR FLAGS

The data processing operations may be classified as logical or arithmetic. The logical operations (AND, EOR, TST, TEQ, ORR, MOV, BIC, MVN) perform the logical action on all corresponding bits of the operand or operands to produce the result. If the S bit is set (and Rd is not R15, see below) the V flag in the CPSR will be unaffected, the C flag will be set to the carry out from the barrel shifter (or preserved when the shift operation is LSL #0), the Z flag will be set if and only if the result is all zeros, and the N flag will be set to the logical value of bit 31 of the result.

**Table 3-3. ARM Data Processing Instructions**

Assembler Mnemonic	Opcode	Action
AND	0000	Operand1 AND operand2
EOR	0001	Operand1 EOR operand2
SUB	0010	Operand1 - operand2
RSB	0011	Operand2 - operand1
ADD	0100	Operand1 + operand2
ADC	0101	Operand1 + operand2 + carry
SBC	0110	Operand1 - operand2 + carry - 1
RSC	0111	Operand2 - operand1 + carry - 1
TST	1000	As AND, but result is not written
TEQ	1001	As EOR, but result is not written
CMP	1010	As SUB, but result is not written
CMN	1011	As ADD, but result is not written
ORR	1100	Operand1 OR operand2
MOV	1101	Operand2 (operand1 is ignored)
BIC	1110	Operand1 AND NOT operand2 (Bit clear)
MVN	1111	NOT operand2 (operand1 is ignored)

The arithmetic operations (SUB, RSB, ADD, ADC, SBC, RSC, CMP, CMN) treat each operand as a 32 bit integer (either unsigned or 2's complement signed, the two are equivalent). If the S bit is set (and Rd is not R15) the V flag in the CPSR will be set if an overflow occurs into bit 31 of the result; this may be ignored if the operands were considered unsigned, but warns of a possible error if the operands were 2's complement signed. The C flag will be set to the carry out of bit 31 of the ALU, the Z flag will be set if and only if the result was zero, and the N flag will be set to the value of bit 31 of the result (indicating a negative result if the operands are considered to be 2's complement signed).

**SHIFTS**

When the second operand is specified to be a shifted register, the operation of the barrel shifter is controlled by the shift field in the instruction. This field indicates the type of shift to be performed (logical left or right, arithmetic right or rotate right). The amount by which the register should be shifted may be contained in an immediate field in the instruction, or in the bottom byte of another register (other than R15). The encoding for the different shift types is shown in Figure 3-5.

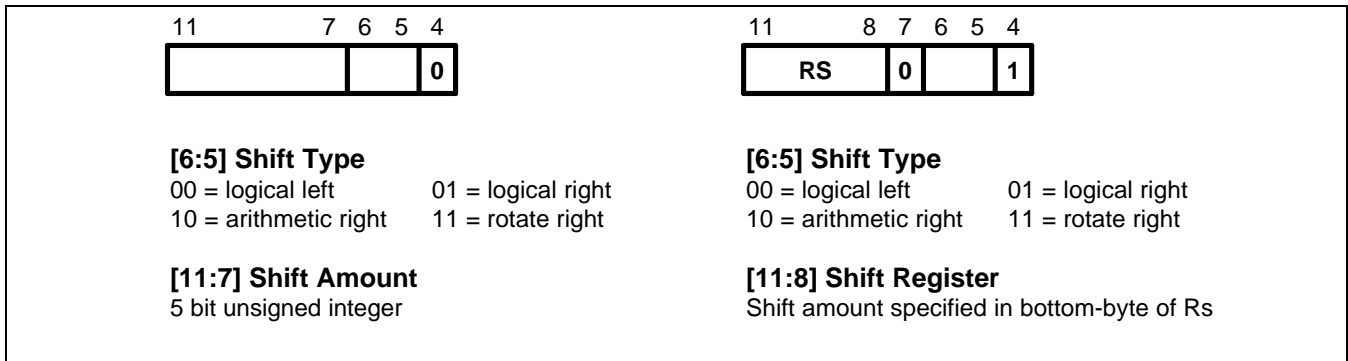

**Figure 3-5. ARM Shift Operations**

**Instruction Specified Shift Amount**

When the shift amount is specified in the instruction, it is contained in a 5 bit field which may take any value from 0 to 31. A logical shift left (LSL) takes the contents of Rm and moves each bit by the specified amount to a more significant position. The least significant bits of the result are filled with zeros, and the high bits of Rm which do not map into the result are discarded, except that the least significant discarded bit becomes the shifter carry output which may be latched into the C bit of the CPSR when the ALU operation is in the logical class (see above). For example, the effect of LSL #5 is shown in Figure 3-6.

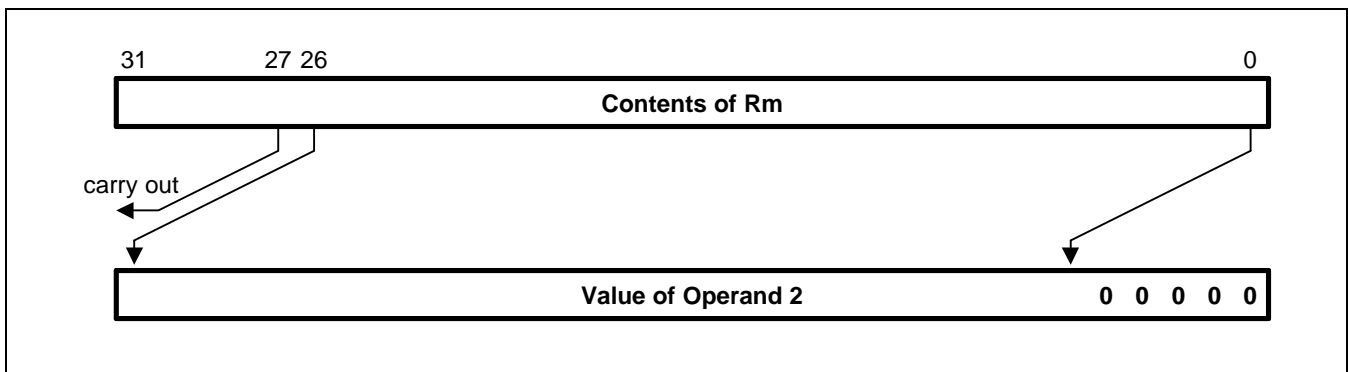

**Figure 3-6. Logical Shift Left**

**NOTE**

LSL #0 is a special case, where the shifter carry out is the old value of the CPSR C flag. The contents of Rm are used directly as the second operand. A logical shift right (LSR) is similar, but the contents of Rm are moved to less significant positions in the result. LSR #5 has the effect shown in Figure 3-7.

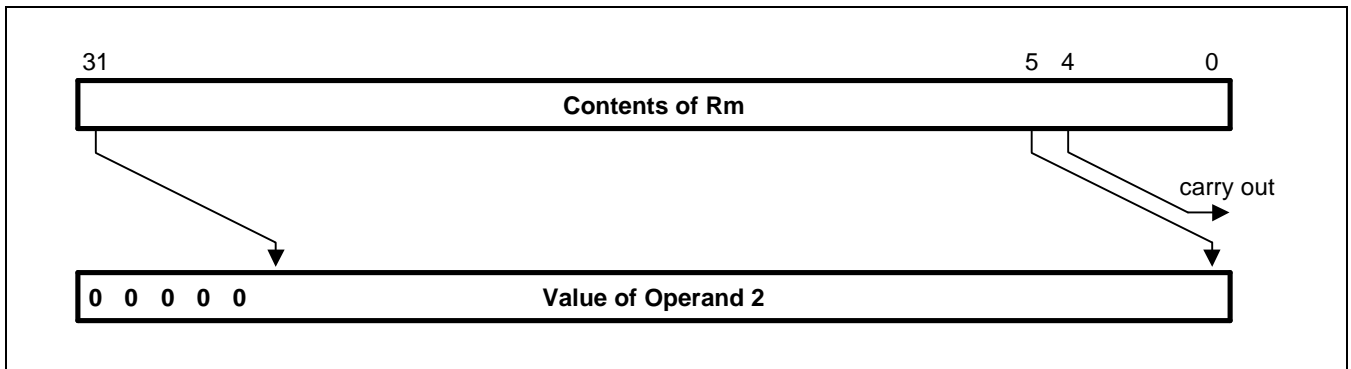

Figure 3-7. Logical Shift Right

The form of the shift field which might be expected to correspond to LSR #0 is used to encode LSR #32, which has a zero result with bit 31 of Rm as the carry output. Logical shift right zero is redundant as it is the same as logical shift left zero, so the assembler will convert LSR #0 (and ASR #0 and ROR #0) into LSL #0, and allow LSR #32 to be specified.

An arithmetic shift right (ASR) is similar to logical shift right, except that the high bits are filled with bit 31 of Rm instead of zeros. This preserves the sign in 2's complement notation. For example, ASR #5 is shown in Figure 3-8.

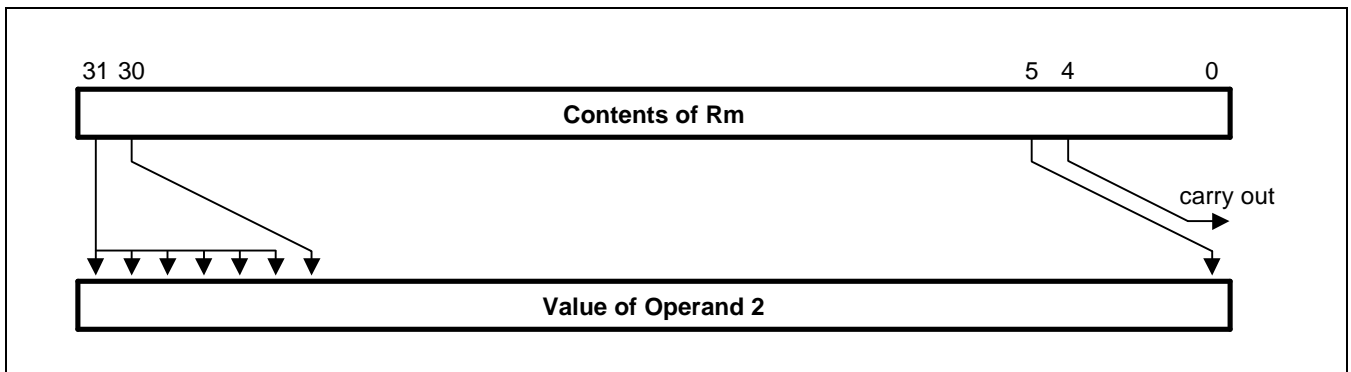

Figure 3-8. Arithmetic Shift Right

The form of the shift field which might be expected to give ASR #0 is used to encode ASR #32. Bit 31 of Rm is again used as the carry output, and each bit of operand 2 is also equal to bit 31 of Rm. The result is therefore all ones or all zeros, according to the value of bit 31 of Rm.

Rotate right (ROR) operations reuse the bits which overshoot in a logical shift right operation by reintroducing them at the high end of the result, in place of the zeros used to fill the high end in logical right operations. For example, ROR #5 is shown in Figure 3-9. The form of the shift field which might be expected to give ROR #0 is

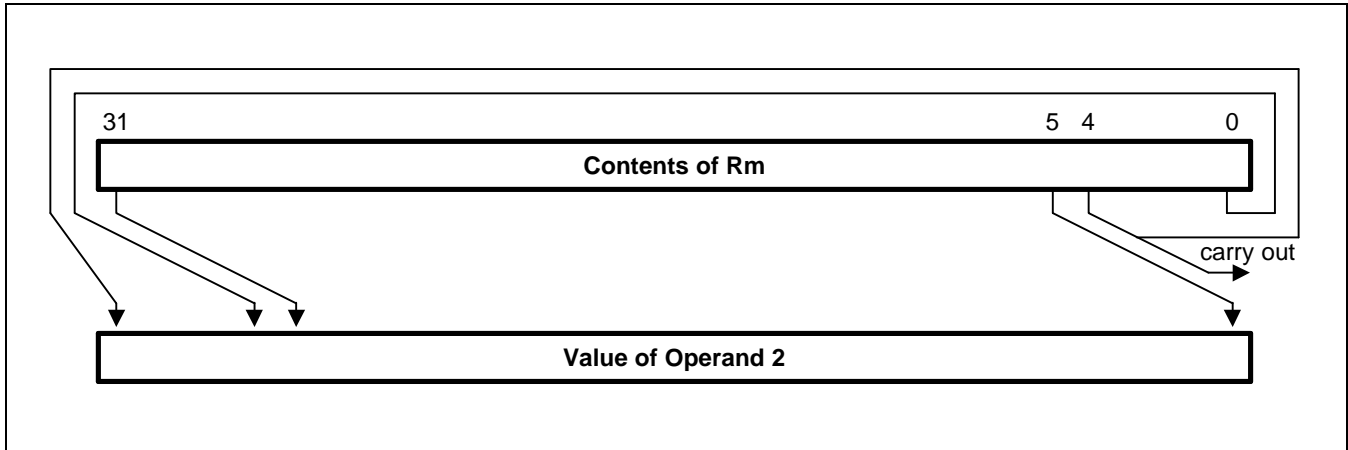

Figure 3-9. Rotate Right

used to encode a special function of the barrel shifter, rotate right extended (RRX). This is a rotate right by one bit position of the 33 bit quantity formed by appending the CPSR C flag to the most significant end of the contents of Rm as shown in Figure 3-10.

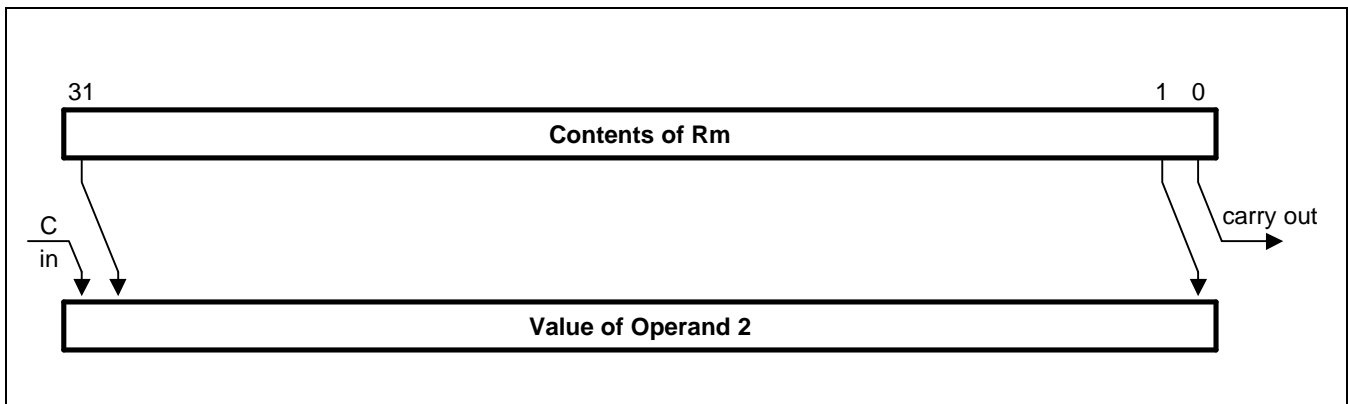

Figure 3-10. Rotate Right Extended



**Register Specified Shift Amount**

Only the least significant byte of the contents of Rs is used to determine the shift amount. Rs can be any general register other than R15.

If this byte is zero, the unchanged contents of Rm will be used as the second operand, and the old value of the CPSR C flag will be passed on as the shifter carry output.

If the byte has a value between 1 and 31, the shifted result will exactly match that of an instruction specified shift with the same value and shift operation.

If the value in the byte is 32 or more, the result will be a logical extension of the shift described above:

1. LSL by 32 has result zero, carry out equal to bit 0 of Rm.
2. LSL by more than 32 has result zero, carry out zero.
3. LSR by 32 has result zero, carry out equal to bit 31 of Rm.
4. LSR by more than 32 has result zero, carry out zero.
5. ASR by 32 or more has result filled with and carry out equal to bit 31 of Rm.
6. ROR by 32 has result equal to Rm, carry out equal to bit 31 of Rm.
7. ROR by n where n is greater than 32 will give the same result and carry out as ROR by n-32; therefore repeatedly subtract 32 from n until the amount is in the range 1 to 32 and see above.

**NOTE**

The zero in bit 7 of an instruction with a register controlled shift is compulsory; a one in this bit will cause the instruction to be a multiply or undefined instruction.

### IMMEDIATE OPERAND ROTATES

The immediate operand rotate field is a 4 bit unsigned integer which specifies a shift operation on the 8 bit immediate value. This value is zero extended to 32 bits, and then subject to a rotate right by twice the value in the rotate field. This enables many common constants to be generated, for example all powers of 2.

### WRITING TO R15

When Rd is a register other than R15, the condition code flags in the CPSR may be updated from the ALU flags as described above.

When Rd is R15 and the S flag in the instruction is not set the result of the operation is placed in R15 and the CPSR is unaffected.

When Rd is R15 and the S flag is set the result of the operation is placed in R15 and the SPSR corresponding to the current mode is moved to the CPSR. This allows state changes which atomically restore both PC and CPSR. This form of instruction should not be used in User mode.

### USING R15 AS AN OPERAND

If R15 (the PC) is used as an operand in a data processing instruction the register is used directly.

The PC value will be the address of the instruction, plus 8 or 12 bytes due to instruction prefetching. If the shift amount is specified in the instruction, the PC will be 8 bytes ahead. If a register is used to specify the shift amount the PC will be 12 bytes ahead.

### TEQ, TST, CMP AND CMN OPCODES

#### NOTE

TEQ, TST, CMP and CMN do not write the result of their operation but do set flags in the CPSR. An assembler should always set the S flag for these instructions even if this is not specified in the mnemonic.

The TEQP form of the TEQ instruction used in earlier ARM processors must not be used: the PSR transfer operations should be used instead.

The action of TEQP in the ARM7TDMI is to move SPSR\_<mode> to the CPSR if the processor is in a privileged mode and to do nothing if in User mode.

## INSTRUCTION CYCLE TIMES

Data processing instructions vary in the number of incremental cycles taken as follows:

**Table 3-4. Incremental Cycle Times**

Processing Type	Cycles
Normal data processing	1S
Data processing with register specified shift	1S + 1I
Data processing with PC written	2S + 1N
Data processing with register specified shift and PC written	2S + 1N + 1I

**NOTE:** S, N and I are as defined sequential (S-cycle), non-sequential (N-cycle), and internal (I-cycle) respectively.

## ASSEMBLER SYNTAX

- MOV, MVN (single operand instructions).  
<opcode>{cond}{S} Rd, <Op2>
- CMP, CMN, TEQ, TST (instructions which do not produce a result).  
<opcode>{cond} Rn, <Op2>
- AND, EOR, SUB, RSB, ADD, ADC, SBC, RSC, ORR, BIC  
<opcode>{cond}{S} Rd, Rn, <Op2>

where:

<Op2>	Rm{,<shift>} or, <#expression>
{cond}	A two-character condition mnemonic. See Table 3-2.
{S}	Set condition codes if S present (implied for CMP, CMN, TEQ, TST).
Rd, Rn and Rm	Expressions evaluating to a register number.
<#expression>	If this is used, the assembler will attempt to generate a shifted immediate 8-bit field to match the expression. If this is impossible, it will give an error.
<shift>	<Shiftname> <register> or <shiftname> #expression, or RRX (rotate right one bit with extend).
<shiftname>	ASL, LSL, LSR, ASR, ROR. (ASL is a synonym for LSL, they assemble to the same code.)

**Examples**

ADDEQ	R2,R4,R5	; If the Z flag is set make R2: = R4 + R5
TEQS	R4,#3	; Test R4 for equality with 3.
		; (The S is in fact redundant as the
		; assembler inserts it automatically.)
SUB	R4,R5,R7,LSR R2	; Logical right shift R7 by the number in
		; the bottom byte of R2, subtract result
		; from R5, and put the answer into R4.
MOV	PC,R14	; Return from subroutine.
MOVS	PC,R14	; Return from exception and restore CPSR
		; from SPSR_mode.

## PSR TRANSFER (MRS, MSR)

The instruction is only executed if the condition is true. The various conditions are defined in Table 3-2.

The MRS and MSR instructions are formed from a subset of the data processing operations and are implemented using the TEQ, TST, CMN and CMP instructions without the S flag set. The encoding is shown in Figure 3-11.

These instructions allow access to the CPSR and SPSR registers. The MRS instruction allows the contents of the CPSR or SPSR\_<mode> to be moved to a general register. The MSR instruction allows the contents of a general register to be moved to the CPSR or SPSR\_<mode> register.

The MSR instruction also allows an immediate value or register contents to be transferred to the condition code flags (N,Z,C and V) of CPSR or SPSR\_<mode> without affecting the control bits. In this case, the top four bits of the specified register contents or 32 bit immediate value are written to the top four bits of the relevant PSR.

## OPERAND RESTRICTIONS

- In user mode, the control bits of the CPSR are protected from change, so only the condition code flags of the CPSR can be changed. In other (privileged) modes the entire CPSR can be changed.
- Note that the software must never change the state of the T bit in the CPSR. If this happens, the processor will enter an unpredictable state.
- The SPSR register which is accessed depends on the mode at the time of execution. For example, only SPSR\_fiq is accessible when the processor is in FIQ mode.
- You must not specify R15 as the source or destination register.
- Also, do not attempt to access an SPSR in User mode, since no such register exists.

**MRS (Transfer PSR Contents to a Register)**

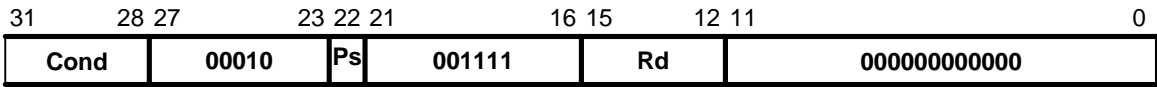

[15:21] Destination Register

[19:16] Source PSR  
 0 = CPSR                      1 = SPSR\_<current mode>

[31:28] Condition Field

**MRS (Transfer Register Contents to PSR)**

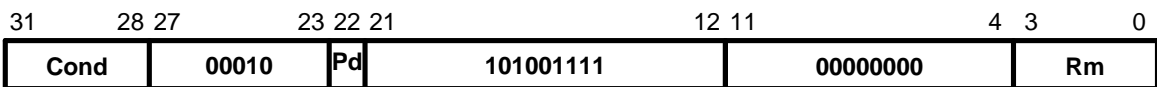

[3:0] Source Register

[22] Destination PSR  
 0 = CPSR                      1 = SPSR\_<current mode>

[31:28] Condition Field

**MRS (Transfer Register Contents or Immediate Value to PSR Flag Bits Only)**

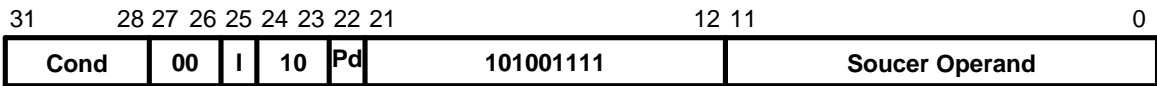

[22] Destination PSR  
 0 = CPSR                      1 = SPSR\_<current mode>

[25] Immediate Operand  
 0 = Source operand is a register  
 1 = SPSR\_<current mode>

[11:0] Source Operand

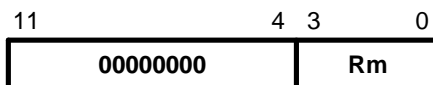

[3:0] Source Register  
 [11:4] Source operand is an immediate value

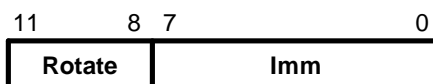

[7:0] Unsigned 8 bit immediate value  
 [11:8] Shift applied to Imm

[31:28] Condition Field

Figure 3-11. PSR Transfer

## RESERVED BITS

Only twelve bits of the PSR are defined in ARM7TDMI (N, Z, C, V, I, F, T & M[4:0]); the remaining bits are reserved for use in future versions of the processor. Refer to Figure 2-6 for a full description of the PSR bits.

To ensure the maximum compatibility between ARM7TDMI programs and future processors, the following rules should be observed:

- The reserved bits should be preserved when changing the value in a PSR.
- Programs should not rely on specific values from the reserved bits when checking the PSR status, since they may read as one or zero in future processors.

A read-modify-write strategy should therefore be used when altering the control bits of any PSR register; this involves transferring the appropriate PSR register to a general register using the MRS instruction, changing only the relevant bits and then transferring the modified value back to the PSR register using the MSR instruction.

## Examples

The following sequence performs a mode change:

```

MRS      R0,CPSR           ; Take a copy of the CPSR.
BIC      R0,R0,#0x1F      ; Clear the mode bits.
ORR      R0,R0,#new_mode  ; Select new mode
MSR      CPSR,R0          ; Write back the modified CPSR.

```

When the aim is simply to change the condition code flags in a PSR, a value can be written directly to the flag bits without disturbing the control bits. The following instruction sets the N, Z, C and V flags:

```

MSR      CPSR_flg,#0xF0000000 ; Set all the flags regardless of their previous state
                                           ; (does not affect any control bits).

```

No attempt should be made to write an 8 bit immediate value into the whole PSR since such an operation cannot preserve the reserved bits.

## INSTRUCTION CYCLE TIMES

PSR transfers take 1S incremental cycles, where S is defined as sequential (S-cycle).

**ASSEMBLER SYNTAX**

- MRS - transfer PSR contents to a register  
MRS{cond} Rd,<psr>
- MSR - transfer register contents to PSR  
MSR{cond} <psr>,Rm
- MSR - transfer register contents to PSR flag bits only  
MSR{cond} <psrf>,Rm

The most significant four bits of the register contents are written to the N,Z,C & V flags respectively.

- MSR - transfer immediate value to PSR flag bits only  
MSR{cond} <psrf>, <#expression>

The expression should symbolise a 32 bit value of which the most significant four bits are written to the N, Z, C and V flags respectively.

**Key:**

{cond}	Two-character condition mnemonic. See Table 3-2.
Rd and Rm	Expressions evaluating to a register number other than R15
<psr>	CPSR, CPSR_all, SPSR or SPSR_all. (CPSR and CPSR_all are synonyms as are
SPSR	and SPSR_all)
<psrf>	CPSR_flg or SPSR_flg
<#expression>	Where this is used, the assembler will attempt to generate a shifted immediate 8-bit field to match the expression. If this is impossible, it will give an error.

**Examples**

In User mode the instructions behave as follows:

```

MSR    CPSR_all,Rm      ; CPSR[31:28] ← Rm[31:28]
MSR    CPSR_flg,Rm     ; CPSR[31:28] ← Rm[31:28]
MSR    CPSR_flg,#0xA0000000 ; CPSR[31:28] ← 0xA (set N, C; clear Z, V)
MRS    Rd,CPSR        ; Rd[31:0] ← CPSR[31:0]

```

In privileged modes the instructions behave as follows:

```

MSR    CPSR_all,Rm      ; CPSR[31:0] ← Rm[31:0]
MSR    CPSR_flg,Rm     ; CPSR[31:28] ← Rm[31:28]
MSR    CPSR_flg,#0x50000000 ; CPSR[31:28] ← 0x5 (set Z, V; clear N, C)
MSR    SPSR_all,Rm     ; SPSR_<mode>[31:0] ← Rm[31:0]
MSR    SPSR_flg,Rm     ; SPSR_<mode>[31:28] ← Rm[31:28]
MSR    SPSR_flg,#0xC0000000 ; SPSR_<mode>[31:28] ← 0xC (set N, Z; clear C, V)
MRS    Rd,SPSR        ; Rd[31:0] ← SPSR_<mode>[31:0]

```



## MULTIPLY AND MULTIPLY-ACCUMULATE (MUL, MLA)

The instruction is only executed if the condition is true. The various conditions are defined in Table 3-2. The instruction encoding is shown in Figure 3-12.

The multiply and multiply-accumulate instructions use an 8 bit Booth's algorithm to perform integer multiplication.

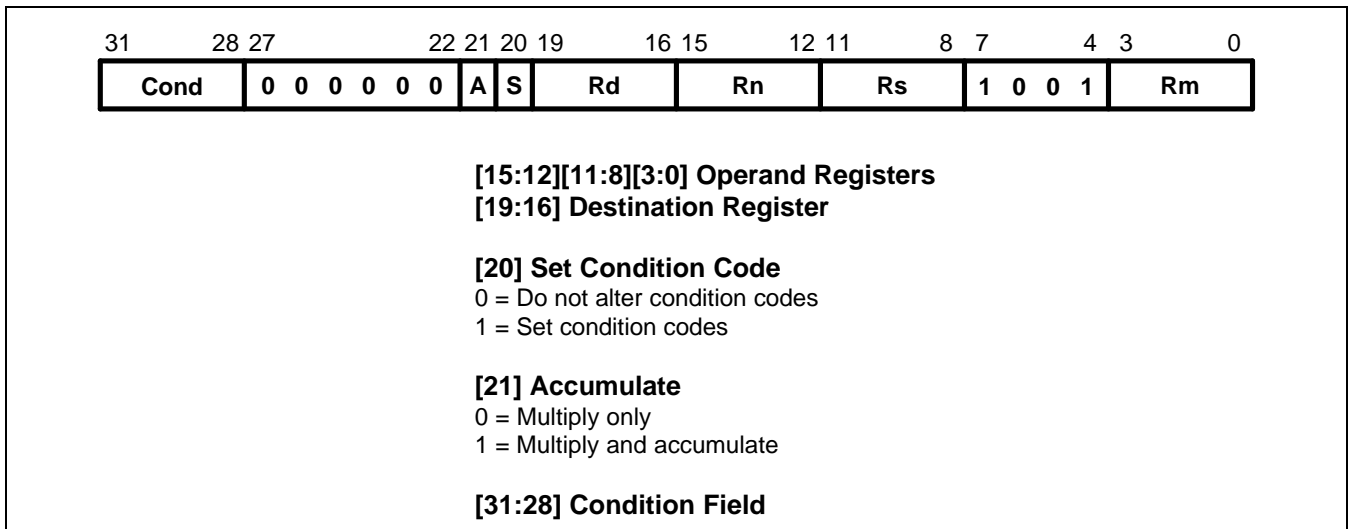

**Figure 3-12. Multiply Instructions**

The multiply form of the instruction gives  $Rd = Rm * Rs$ .  $Rn$  is ignored, and should be set to zero for compatibility with possible future upgrades to the instruction set. The multiply-accumulate form gives  $Rd = Rm * Rs + Rn$ , which can save an explicit ADD instruction in some circumstances. Both forms of the instruction work on operands which may be considered as signed (2' complement) or unsigned integers.

The results of a signed multiply and of an unsigned multiply of 32 bit operands differ only in the upper 32 bits—the low 32 bits of the signed and unsigned results are identical. As these instructions only produce the low 32 bits of a multiply, they can be used for both signed and unsigned multiplies.

For example consider the multiplication of the operands:

Operand A	Operand B	Result
0xFFFFFFFF6	0x0000001	0xFFFFFFFF38

### If the Operands are Interpreted as Signed

Operand A has the value -10, operand B has the value 20, and the result is -200 which is correctly represented as 0xFFFFFFFF38.

### If the Operands are Interpreted as Unsigned

Operand A has the value 4294967286, operand B has the value 20 and the result is 85899345720, which is represented as 0x13FFFFFF38, so the least significant 32 bits are 0xFFFFFFFF38.

### Operand Restrictions

The destination register  $Rd$  must not be the same as the operand register  $Rm$ .  $R15$  must not be used as an operand or as the destination register.

All other register combinations will give correct results, and  $Rd$ ,  $Rn$  and  $Rs$  may use the same register when required.

**CPSR FLAGS**

Setting the CPSR flags is optional, and is controlled by the S bit in the instruction. The N (Negative) and Z (Zero) flags are set correctly on the result (N is made equal to bit 31 of the result, and Z is set if and only if the result is zero). The C (Carry) flag is set to a meaningless value and the V (overflow) flag is unaffected.

**INSTRUCTION CYCLE TIMES**

MUL takes  $1S + mI$  and MLA  $1S + (m+1)I$  cycles to execute, where S and I are defined as sequential (S-cycle) and internal (I-cycle), respectively.

m	The number of 8 bit multiplier array cycles is required to complete the multiply, which is controlled by the value of the multiplier operand specified by Rs. Its possible values are as follows
1	If bits [32:8] of the multiplier operand are all zero or all one.
2	If bits [32:16] of the multiplier operand are all zero or all one.
3	If bits [32:24] of the multiplier operand are all zero or all one.
4	In all other cases.

**ASSEMBLER SYNTAX**

MUL{cond}{S} Rd,Rm,Rs  
 MLA{cond}{S} Rd,Rm,Rs,Rn

{cond}	Two-character condition mnemonic. See Table 3-2.
{S}	Set condition codes if S present
Rd, Rm, Rs and Rn	Expressions evaluating to a register number other than R15.

**Examples**

```
MUL      R1,R2,R3      ; R1: = R2 * R3
MLAEQS   R1,R2,R3,R4  ; Conditionally R1: = R2 * R3 + R4, setting condition
                        codes.
```

## MULTIPLY LONG AND MULTIPLY-ACCUMULATE LONG (MULL,MLAL)

The instruction is only executed if the condition is true. The various conditions are defined in Table 3-2. The instruction encoding is shown in Figure 3-13.

The multiply long instructions perform integer multiplication on two 32 bit operands and produce 64 bit results. Signed and unsigned multiplication each with optional accumulate give rise to four variations.

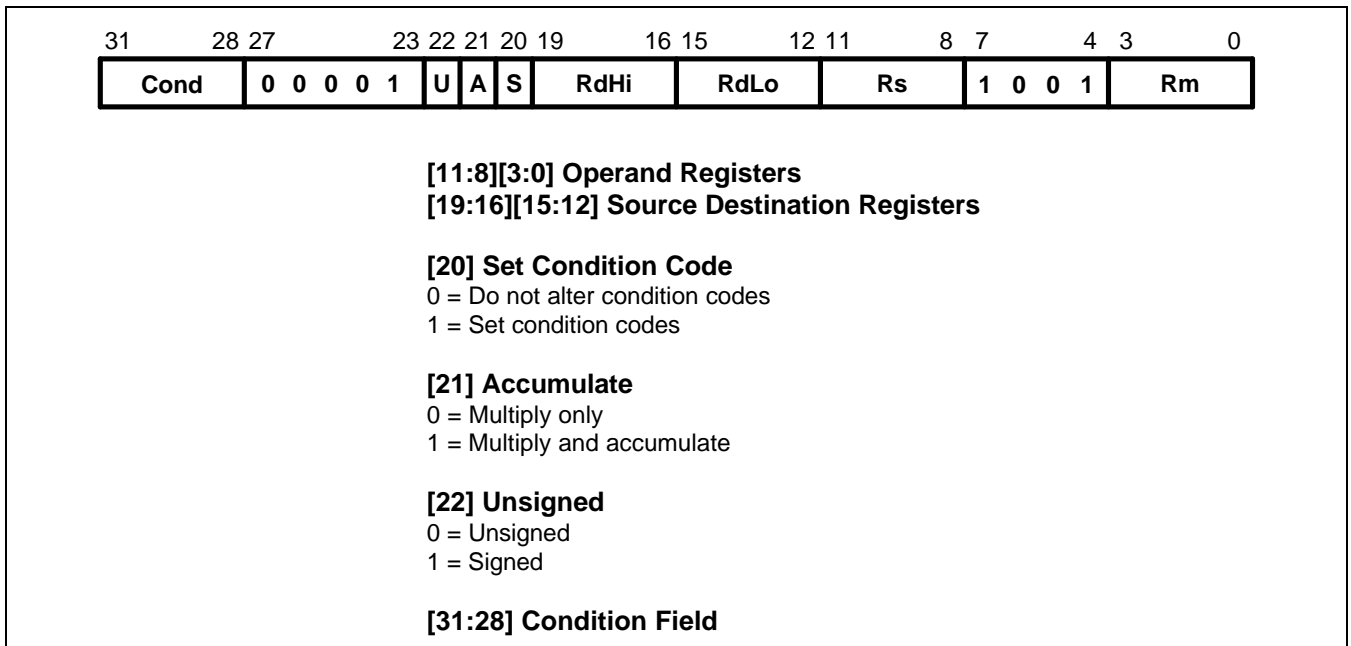

**Figure 3-13. Multiply Long Instructions**

The multiply forms (UMULL and SMULL) take two 32 bit numbers and multiply them to produce a 64 bit result of the form RdHi, RdLo: = Rm \* Rs. The lower 32 bits of the 64 bit result are written to RdLo, the upper 32 bits of the result are written to RdHi.

The multiply-accumulate forms (UMLAL and SMLAL) take two 32 bit numbers, multiply them and add a 64 bit number to produce a 64 bit result of the form RdHi, RdLo: = Rm \* Rs + RdHi, RdLo. The lower 32 bits of the 64 bit number to add is read from RdLo. The upper 32 bits of the 64 bit number to add is read from RdHi. The lower 32 bits of the 64 bit result are written to RdLo. The upper 32 bits of the 64 bit result are written to RdHi.

The UMULL and UMLAL instructions treat all of their operands as unsigned binary numbers and write an unsigned 64 bit result. The SMULL and SMLAL instructions treat all of their operands as two's-complement signed numbers and write a two's-complement signed 64 bit result.

### OPERAND RESTRICTIONS

- R15 must not be used as an operand or as a destination register.
- RdHi, RdLo, and Rm must all specify different registers.

**CPSR FLAGS**

Setting the CPSR flags is optional, and is controlled by the S bit in the instruction. The N and Z flags are set correctly on the result (N is equal to bit 63 of the result, Z is set if and only if all 64 bits of the result are zero). Both the C and V flags are set to meaningless values.

**INSTRUCTION CYCLE TIMES**

MULL takes  $1S + (m+1)I$  and MLAL  $1S + (m+2)I$  cycles to execute, where  $m$  is the number of 8 bit multiplier array cycles required to complete the multiply, which is controlled by the value of the multiplier operand specified by Rs.

Its possible values are as follows:

**For Signed Instructions SMULL, SMLAL:**

- If bits [31:8] of the multiplier operand are all zero or all one.
- If bits [31:16] of the multiplier operand are all zero or all one.
- If bits [31:24] of the multiplier operand are all zero or all one.
- In all other cases.

**For Unsigned Instructions UMULL, UMLAL:**

- If bits [31:8] of the multiplier operand are all zero.
- If bits [31:16] of the multiplier operand are all zero.
- If bits [31:24] of the multiplier operand are all zero.
- In all other cases.

S and I are defined as sequential (S-cycle) and internal (I-cycle), respectively.

## ASSEMBLER SYNTAX

Table 3-5. Assembler Syntax Descriptions

Mnemonic	Description	Purpose
UMULL{cond}{S} RdLo, RdHi, Rm, Rs	Unsigned multiply long	$32 \times 32 = 64$
UMLAL{cond}{S} RdLo, RdHi, Rm, Rs	Unsigned multiply & Accumulate long	$32 \times 32 + 64 = 64$
SMULL{cond}{S} RdLo, RdHi, Rm, Rs	Signed multiply long	$32 \times 32 = 64$
SMLAL{cond}{S} RdLo, RdHi, Rm, Rs	Signed multiply & Accumulate long	$32 \times 32 + 64 = 64$

where:

{cond} Two-character condition mnemonic. See Table 3-2.  
 {S} Set condition codes if S present  
 RdLo, RdHi, Rm, Rs Expressions evaluating to a register number other than R15.

## Examples

```
UMULL    R1, R4, R2, R3    ; R4, R1: = R2 * R3
UMLALS   R1, R5, R2, R3    ; R5, R1: = R2 * R3 + R5, R1 also setting condition codes
```

## SINGLE DATA TRANSFER (LDR, STR)

The instruction is only executed if the condition is true. The various conditions are defined in Table 3-2. The instruction encoding is shown in Figure 3-14.

The single data transfer instructions are used to load or store single bytes or words of data. The memory address used in the transfer is calculated by adding an offset to or subtracting an offset from a base register.

The result of this calculation may be written back into the base register if auto-indexing is required.

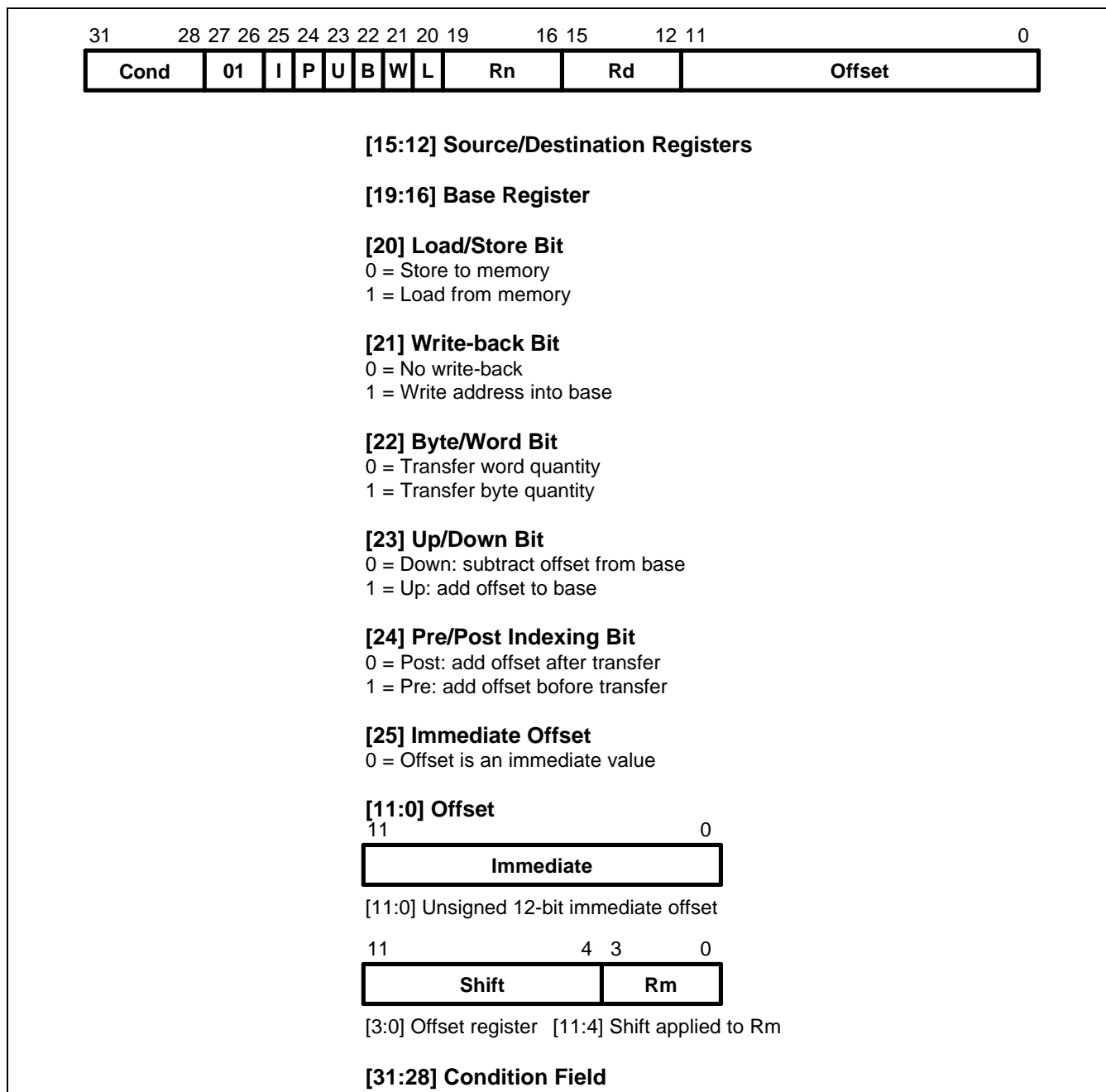

Figure 3-14. Single Data Transfer Instructions

## OFFSETS AND AUTO-INDEXING

The offset from the base may be either a 12 bit unsigned binary immediate value in the instruction, or a second register (possibly shifted in some way). The offset may be added to ( $U = 1$ ) or subtracted from ( $U = 0$ ) the base register  $R_n$ . The offset modification may be performed either before (pre-indexed,  $P = 1$ ) or after (post-indexed,  $P = 0$ ) the base is used as the transfer address.

The  $W$  bit gives optional auto increment and decrement addressing modes. The modified base value may be written back into the base ( $W = 1$ ), or the old base value may be kept ( $W = 0$ ). In the case of post-indexed addressing, the write back bit is redundant and is always set to zero, since the old base value can be retained by setting the offset to zero. Therefore post-indexed data transfers always write back the modified base. The only use of the  $W$  bit in a post-indexed data transfer is in privileged mode code, where setting the  $W$  bit forces non-privileged mode for the transfer, allowing the operating system to generate a user address in a system where the memory management hardware makes suitable use of this hardware.

## SHIFTED REGISTER OFFSET

The 8 shift control bits are described in the data processing instructions section. However, the register specified shift amounts are not available in this instruction class. See Figure 3-5.

## BYTES AND WORDS

This instruction class may be used to transfer a byte ( $B = 1$ ) or a word ( $B = 0$ ) between an ARM7TDMI register and memory.

The action of LDR(B) and STR(B) instructions is influenced by the BIGEND control signal of ARM7TDMI core. The two possible configurations are described below.

### Little-Endian Configuration

A byte load (LDRB) expects the data on data bus inputs 7 through 0 if the supplied address is on a word boundary, on data bus inputs 15 through 8 if it is a word address plus one byte, and so on. The selected byte is placed in the bottom 8 bits of the destination register, and the remaining bits of the register are filled with zeros. Please see Figure 2-2.

A byte store (STRB) repeats the bottom 8 bits of the source register four times across data bus outputs 31 through 0. The external memory system should activate the appropriate byte subsystem to store the data.

A word load (LDR) will normally use a word aligned address. However, an address offset from a word boundary will cause the data to be rotated into the register so that the addressed byte occupies bits 0 to 7. This means that half-words accessed at offsets 0 and 2 from the word boundary will be correctly loaded into bits 0 through 15 of the register. Two shift operations are then required to clear or to sign extend the upper 16 bits.

A word store (STR) should generate a word aligned address. The word presented to the data bus is not affected if the address is not word aligned. That is, bit 31 of the register being stored always appears on data bus output 31.

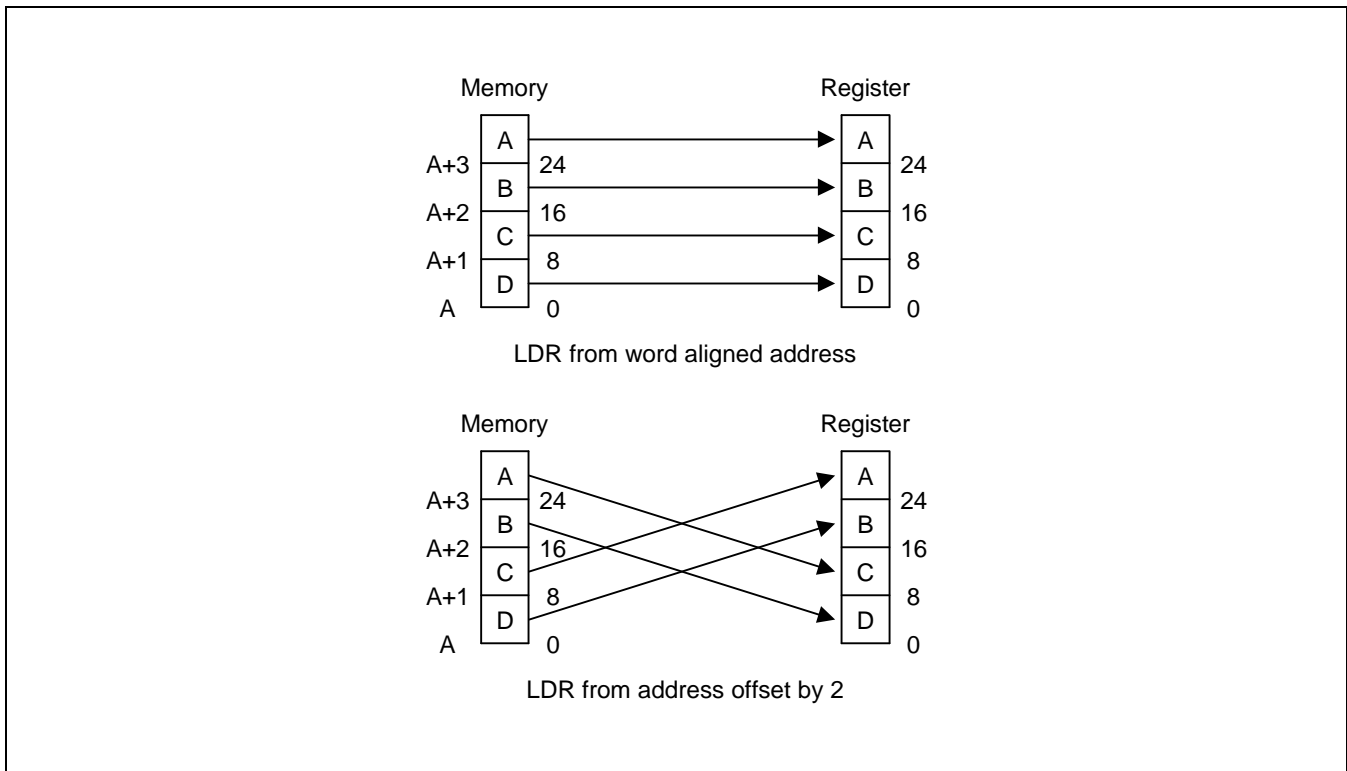

Figure 3-15. Little-Endian Offset Addressing

### Big-Endian Configuration

A byte load (LDRB) expects the data on data bus inputs 31 through 24 if the supplied address is on a word boundary, on data bus inputs 23 through 16 if it is a word address plus one byte, and so on. The selected byte is placed in the bottom 8 bits of the destination register and the remaining bits of the register are filled with zeros. Please see Figure 2-1.

A byte store (STRB) repeats the bottom 8 bits of the source register four times across data bus outputs 31 through 0. The external memory system should activate the appropriate byte subsystem to store the data.

A word load (LDR) should generate a word aligned address. An address offset of 0 or 2 from a word boundary will cause the data to be rotated into the register so that the addressed byte occupies bits 31 through 24. This means that half-words accessed at these offsets will be correctly loaded into bits 16 through 31 of the register. A shift operation is then required to move (and optionally sign extend) the data into the bottom 16 bits. An address offset of 1 or 3 from a word boundary will cause the data to be rotated into the register so that the addressed byte occupies bits 15 through 8.

A word store (STR) should generate a word aligned address. The word presented to the data bus is not affected if the address is not word aligned. That is, bit 31 of the register being stored always appears on data bus output 31.



## USE OF R15

Write-back must not be specified if R15 is specified as the base register (Rn). When using R15 as the base register you must remember it contains an address 8 bytes on from the address of the current instruction.

R15 must not be specified as the register offset (Rm).

When R15 is the source register (Rd) of a register store (STR) instruction, the stored value will be address of the instruction plus 12.

## RESTRICTION ON THE USE OF BASE REGISTER

When configured for late aborts, the following example code is difficult to unwind as the base register, Rn, gets updated before the abort handler starts. Sometimes it may be impossible to calculate the initial value.

After an abort, the following example code is difficult to unwind as the base register, Rn, gets updated before the abort handler starts. Sometimes it may be impossible to calculate the initial value.

### Example:

```
LDR    R0,[R1],R1
```

Therefore a post-indexed LDR or STR where Rm is the same register as Rn should not be used.

## DATA ABORTS

A transfer to or from a legal address may cause problems for a memory management system. For instance, in a system which uses virtual memory the required data may be absent from main memory. The memory manager can signal a problem by taking the processor ABORT input HIGH whereupon the data abort trap will be taken. It is up to the system software to resolve the cause of the problem, then the instruction can be restarted and the original program continued.

## INSTRUCTION CYCLE TIMES

Normal LDR instructions take  $1S + 1N + 1I$  and LDR PC take  $2S + 2N + 1I$  incremental cycles, where S,N and I are defined as sequential (S-cycle), non-sequential (N-cycle), and internal (I-cycle), respectively. STR instructions take  $2N$  incremental cycles to execute.

**ASSEMBLER SYNTAX**

<LDR|STR>{cond}{B}{T} Rd,<Address>

where:

LDR	Load from memory into a register
STR	Store from a register into memory
{cond}	Two-character condition mnemonic. See Table 3-2.
{B}	If B is present then byte transfer, otherwise word transfer
{T}	If T is present the W bit will be set in a post-indexed instruction, forcing non-privileged mode for the transfer cycle. T is not allowed when a pre-indexed addressing mode is specified or implied.
Rd	An expression evaluating to a valid register number.
Rn and Rm	Expressions evaluating to a register number. If Rn is R15 then the assembler will subtract 8 from the offset value to allow for ARM7TDMI pipelining. In this case base write-back should not be specified.

<Address>can be:

1	An expression which generates an address: The assembler will attempt to generate an instruction using the PC as a base and a corrected immediate offset to address the location given by evaluating the expression. This will be a PC relative, pre-indexed address. If the address is out of range, an error will be generated.
2	A pre-indexed addressing specification: [Rn] offset of zero [Rn,<#expression>]{!} offset of <expression> bytes [Rn,{+/-}Rm{,<shift>}]{} offset of +/- contents of index register, shifted by <shift>
3	A post-indexed addressing specification: [Rn],<#expression> offset of <expression> bytes [Rn},{+/-}Rm{,<shift>} offset of +/- contents of index register, shifted as by <shift>.
<shift>	General shift operation (see data processing instructions) but you cannot specify the shift amount by a register.
{!}	Writes back the base register (set the W bit) if ! is present.

**Examples**

STR	R1,[R2,R4]!	; Store R1 at R2 + R4 (both of which are registers)
		; and write back address to R2.
STR	R1,[R2],R4	; Store R1 at R2 and write back R2 + R4 to R2.
LDR	R1,[R2,#16]	; Load R1 from contents of R2 + 16, but don't write back.
LDR	R1,[R2,R3,LSL#2]	; Load R1 from contents of R2 + R3 * 4.
LDREQB	R1,[R6,#5]	; Conditionally load byte at R6 + 5 into
		; R1 bits 0 to 7, filling bits 8 to 31 with zeros.
STR	R1,PLACE	; Generate PC relative offset to address PLACE.
PLACE		

## HALFWORD AND SIGNED DATA TRANSFER (LDRH/STRH/LDRSB/LDRSH)

The instruction is only executed if the condition is true. The various conditions are defined in Table 3-2. The instruction encoding is shown in Figure 3-16.

These instructions are used to load or store half-words of data and also load sign-extended bytes or half-words of data. The memory address used in the transfer is calculated by adding an offset to or subtracting an offset from a base register. The result of this calculation may be written back into the base register if auto-indexing is required.

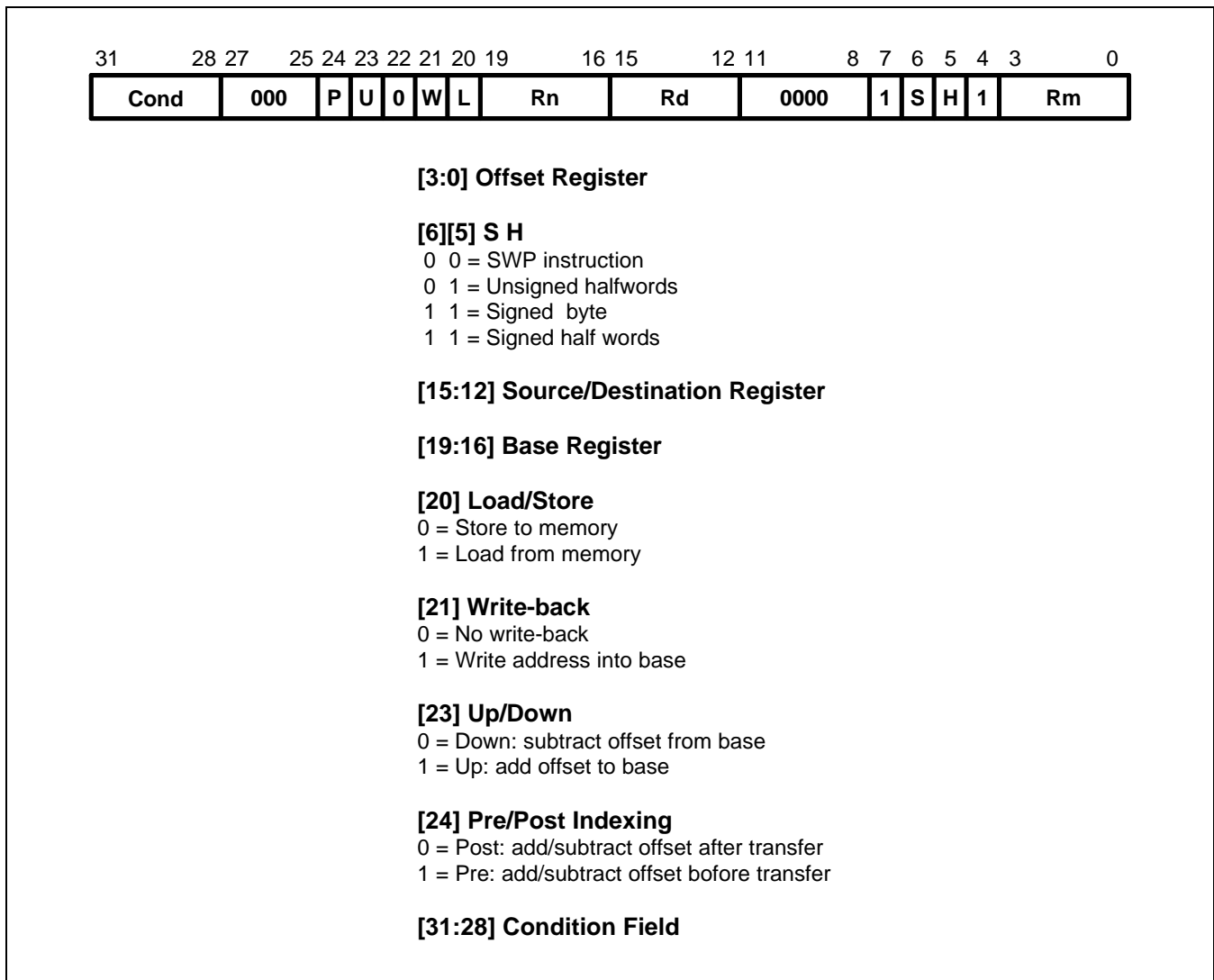
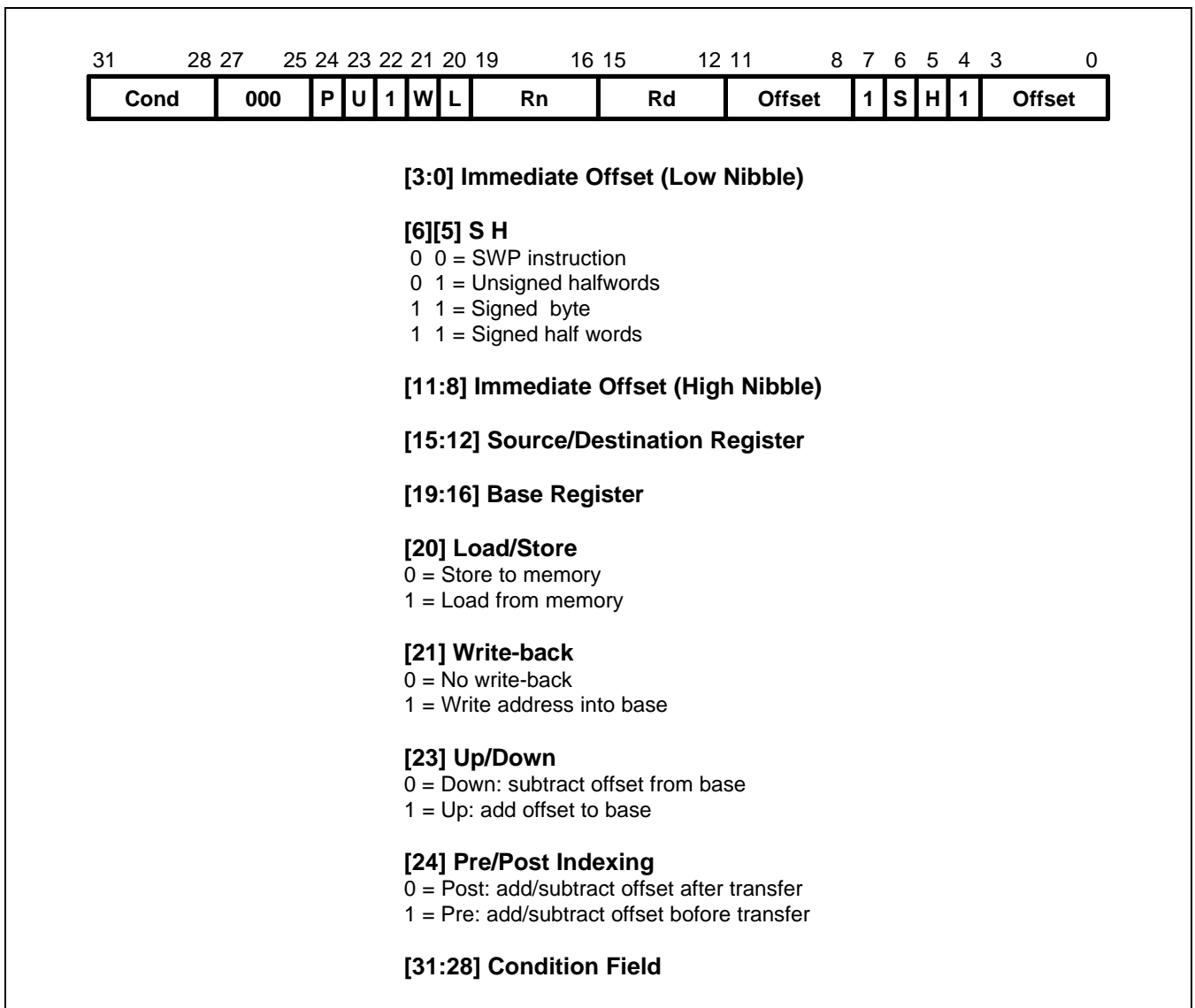

Figure 3-16. Half-word and Signed Data Transfer with Register Offset



**Figure 3-17. Half-word and Signed Data Transfer with Immediate Offset and Auto-Indexing**

## OFFSETS AND AUTO-INDEXING

The offset from the base may be either a 8-bit unsigned binary immediate value in the instruction, or a second register. The 8-bit offset is formed by concatenating bits 11 to 8 and bits 3 to 0 of the instruction word, such that bit 11 becomes the MSB and bit 0 becomes the LSB. The offset may be added to (U = 1) or subtracted from (U = 0) the base register Rn. The offset modification may be performed either before (pre-indexed, P = 1) or after (post-indexed, P = 0) the base register is used as the transfer address.

The W bit gives optional auto-increment and decrement addressing modes. The modified base value may be written back into the base (W = 1), or the old base may be kept (W = 0). In the case of post-indexed addressing, the write back bit is redundant and is always set to zero, since the old base value can be retained if necessary by setting the offset to zero. Therefore post-indexed data transfers always write back the modified base.

The Write-back bit should not be set high (W = 1) when post-indexed addressing is selected.

## HALF-WORD LOAD AND STORES

Setting  $S = 0$  and  $H = 1$  may be used to transfer unsigned Half-words between an ARM7TDMI register and memory.

The action of LDRH and STRH instructions is influenced by the BIGEND control signal. The two possible configurations are described in the section below.

## SIGNED BYTE AND HALF-WORD LOADS

The S bit controls the loading of sign-extended data. When  $S = 1$  the H bit selects between Bytes ( $H = 0$ ) and Half-words ( $H = 1$ ). The L bit should not be set low (Store) when Signed ( $S = 1$ ) operations have been selected.

The LDRSB instruction loads the selected Byte into bits 7 to 0 of the destination register and bits 31 to 8 of the destination register are set to the value of bit 7, the sign bit.

The LDRSH instruction loads the selected Half-word into bits 15 to 0 of the destination register and bits 31 to 16 of the destination register are set to the value of bit 15, the sign bit.

The action of the LDRSB and LDRSH instructions is influenced by the BIGEND control signal. The two possible configurations are described in the following section.

## ENDIANNESS AND BYTE/HALF-WORD SELECTION

### Little-Endian Configuration

A signed byte load (LDRSB) expects data on data bus inputs 7 through to 0 if the supplied address is on a word boundary, on data bus inputs 15 through to 8 if it is a word address plus one byte, and so on. The selected byte is placed in the bottom 8 bit of the destination register, and the remaining bits of the register are filled with the sign bit, bit 7 of the byte. Please see Figure 2-2.

A half-word load (LDRSH or LDRH) expects data on data bus inputs 15 through to 0 if the supplied address is on a word boundary and on data bus inputs 31 through to 16 if it is a half-word boundary, ( $A[1]=1$ ). The supplied address should always be on a half-word boundary. If bit 0 of the supplied address is high then the ARM7TDMI will load an unpredictable value. The selected half-word is placed in the bottom 16 bits of the destination register. For unsigned half-words (LDRH), the top 16 bits of the register are filled with zeros and for signed half-words (LDRSH) the top 16 bits are filled with the sign bit, bit 15 of the half-word.

A half-word store (STRH) repeats the bottom 16 bits of the source register twice across the data bus outputs 31 through to 0. The external memory system should activate the appropriate half-word subsystem to store the data. Note that the address must be half-word aligned, if bit 0 of the address is high this will cause unpredictable behaviour.

### Big-Endian Configuration

A signed byte load (LDRSB) expects data on data bus inputs 31 through to 24 if the supplied address is on a word boundary, on data bus inputs 23 through to 16 if it is a word address plus one byte, and so on. The selected byte is placed in the bottom 8 bit of the destination register, and the remaining bits of the register are filled with the sign bit, bit 7 of the byte. Please see Figure 2-1.

A half-word load (LDRSH or LDRH) expects data on data bus inputs 31 through to 16 if the supplied address is on a word boundary and on data bus inputs 15 through to 0 if it is a half-word boundary, ( $A[1] = 1$ ). The supplied address should always be on a half-word boundary. If bit 0 of the supplied address is high then the ARM7TDMI will load an unpredictable value. The selected half-word is placed in the bottom 16 bits of the destination register. For unsigned half-words (LDRH), the top 16 bits of the register are filled with zeros and for signed half-words (LDRSH) the top 16 bits are filled with the sign bit, bit 15 of the half-word.

A half-word store (STRH) repeats the bottom 16 bits of the source register twice across the data bus outputs 31 through to 0. The external memory system should activate the appropriate half-word subsystem to store the data. Note that the address must be half-word aligned, if bit 0 of the address is HIGH this will cause unpredictable behaviour.

### USE OF R15

Write-back should not be specified if R15 is specified as the base register ( $R_n$ ). When using R15 as the base register you must remember it contains an address 8 bytes on from the address of the current instruction.

R15 should not be specified as the register offset ( $R_m$ ).

When R15 is the source register ( $R_d$ ) of a Half-word store (STRH) instruction, the stored address will be address of the instruction plus 12.

### DATA ABORTS

A transfer to or from a legal address may cause problems for a memory management system. For instance, in a system which uses virtual memory the required data may be absent from the main memory. The memory manager can signal a problem by taking the processor ABORT input high whereupon the data abort trap will be taken. It is up to the system software to resolve the cause of the problem, then the instruction can be restarted and the original program continued.

### INSTRUCTION CYCLE TIMES

Normal LDR(H, SH, SB) instructions take  $1S + 1N + 1I$ . LDR(H, SH, SB) PC take  $2S + 2N + 1I$  incremental cycles. S, N and I are defined as sequential (S-cycle), non-sequential (N-cycle), and internal (I-cycle), respectively. STRH instructions take 2N incremental cycles to execute.

**ASSEMBLER SYNTAX**

<LDR|STR>{cond}<H|SH|SB> Rd,<address>

LDR	Load from memory into a register
STR	Store from a register into memory
{cond}	Two-character condition mnemonic. See Table 3-2.
H	Transfer half-word quantity
SB	Load sign extended byte (Only valid for LDR)
SH	Load sign extended half-word (Only valid for LDR)
Rd	An expression evaluating to a valid register number.

<address> can be:

- 1 An expression which generates an address:  
The assembler will attempt to generate an instruction using the PC as a base and a corrected immediate offset to address the location given by evaluating the expression. This will be a PC relative, pre-indexed address. If the address is out of range, an error will be generated.
- 2 A pre-indexed addressing specification:  

[Rn]	offset of zero
[Rn,<#expression>]{!}	offset of <expression> bytes
[Rn,{+/-}Rm]{!}	offset of +/- contents of index register
- 3 A post-indexed addressing specification:  

[Rn],<#expression>	offset of <expression> bytes
[Rn,{+/-}Rm]	offset of +/- contents of index register.
- 4 Rn and Rm are expressions evaluating to a register number. If Rn is R15 then the assembler will subtract 8 from the offset value to allow for ARM7TDMI pipelining. In this case base write-back should not be specified.
- {!} Writes back the base register (set the W bit) if ! is present.



**Examples**

LDRH	R1,[R2,-R3]!	; Load R1 from the contents of the half-word address ; contained in R2-R3 (both of which are registers) ; and write back address to R2
STRH	R3,[R4,#14]	; Store the half-word in R3 at R14+14 but don't write back.
LDRSB	R8,[R2],#-223	; Load R8 with the sign extended contents of the byte ; address contained in R2 and write back R2-223 to R2.
LDRNESH	R11,[R0]	; Conditionally load R11 with the sign extended contents ; of the half-word address contained in R0.
HERE		; Generate PC relative offset to address FRED.
STRH	R5, [PC,#(FRED-HERE-8)];	Store the half-word in R5 at address FRED
FRED		

## BLOCK DATA TRANSFER (LDM, STM)

The instruction is only executed if the condition is true. The various conditions are defined in Table 3-2. The instruction encoding is shown in Figure 3-18.

Block data transfer instructions are used to load (LDM) or store (STM) any subset of the currently visible registers. They support all possible stacking modes, maintaining full or empty stacks which can grow up or down memory, and are very efficient instructions for saving or restoring context, or for moving large blocks of data around main memory.

### THE REGISTER LIST

The instruction can cause the transfer of any registers in the current bank (and non-user mode programs can also transfer to and from the user bank, see below). The register list is a 16 bit field in the instruction, with each bit corresponding to a register. A 1 in bit 0 of the register field will cause R0 to be transferred, a 0 will cause it not to be transferred; similarly bit 1 controls the transfer of R1, and so on.

Any subset of the registers, or all the registers, may be specified. The only restriction is that the register list should not be empty.

Whenever R15 is stored to memory the stored value is the address of the STM instruction plus 12.

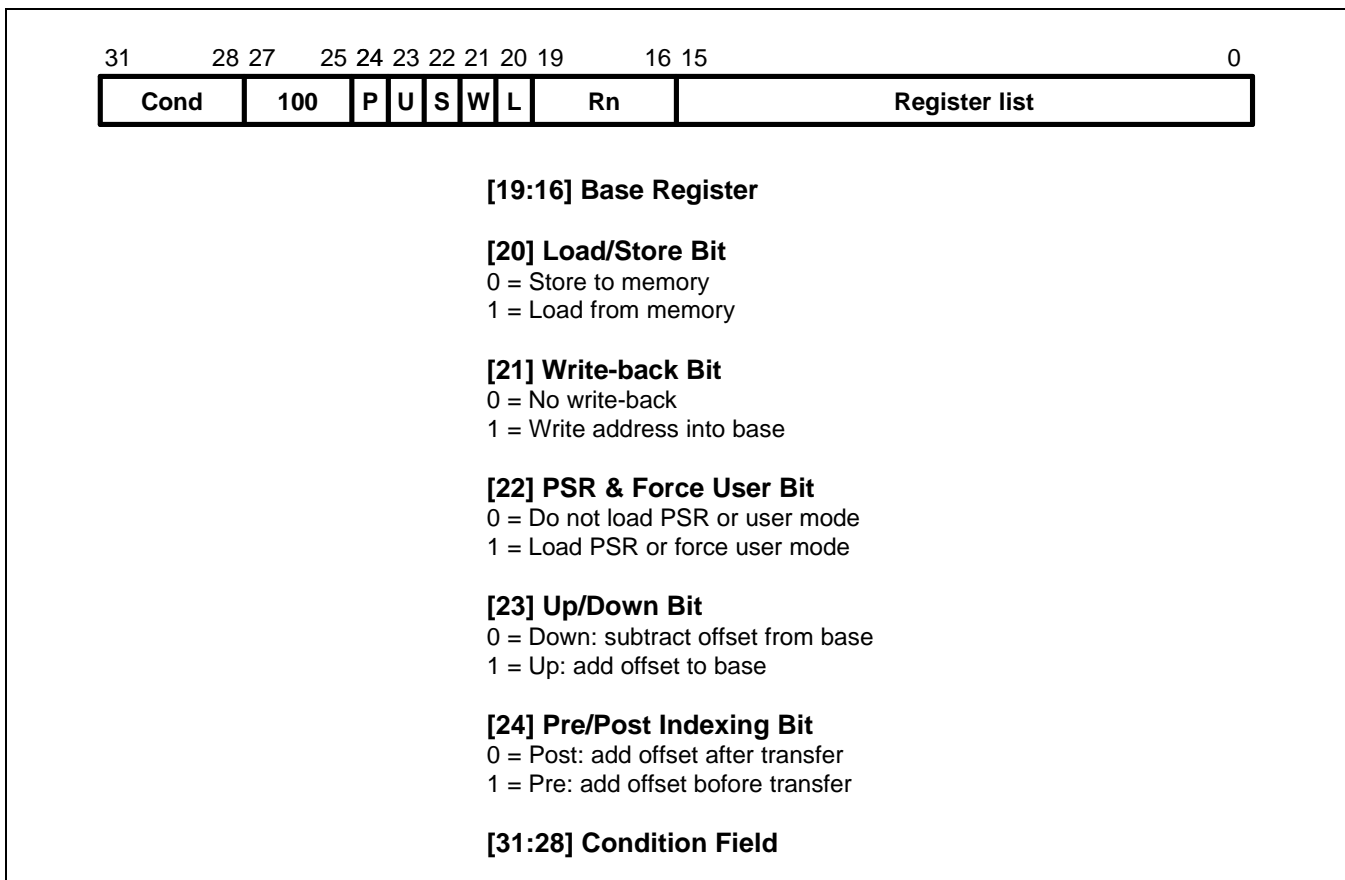

Figure 3-18. Block Data Transfer Instructions

## ADDRESSING MODES

The transfer addresses are determined by the contents of the base register (Rn), the pre/post bit (P) and the up/down bit (U). The registers are transferred in the order lowest to highest, so R15 (if in the list) will always be transferred last. The lowest register also gets transferred to/from the lowest memory address. By way of illustration, consider the transfer of R1, R5 and R7 in the case where Rn = 0x1000 and write back of the modified base is required (W = 1). Figure 3.19-22 show the sequence of register transfers, the addresses used, and the value of Rn after the instruction has completed.

In all cases, had write back of the modified base not been required (W = 0), Rn would have retained its initial value of 0x1000 unless it was also in the transfer list of a load multiple register instruction, when it would have been overwritten with the loaded value.

## ADDRESS ALIGNMENT

The address should normally be a word aligned quantity and non-word aligned addresses do not affect the instruction. However, the bottom 2 bits of the address will appear on A[1:0] and might be interpreted by the memory system.

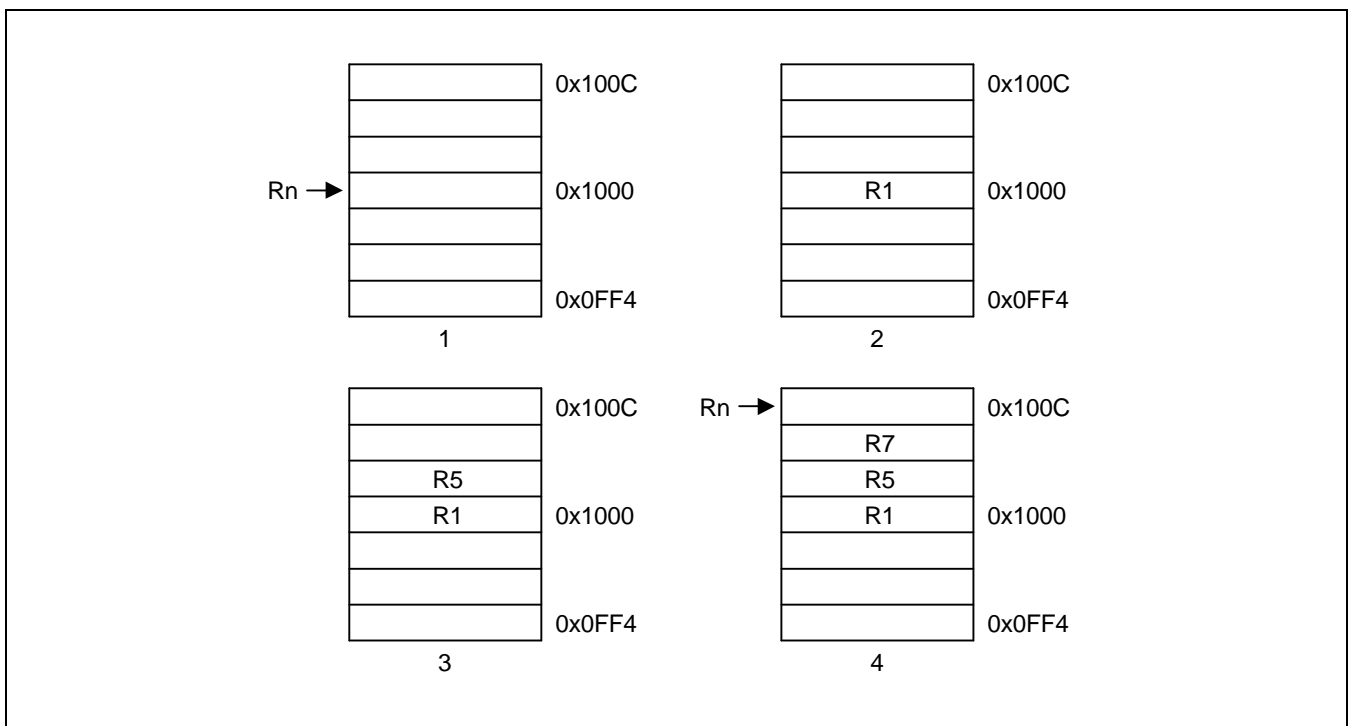

Figure 3-19. Post-Increment Addressing

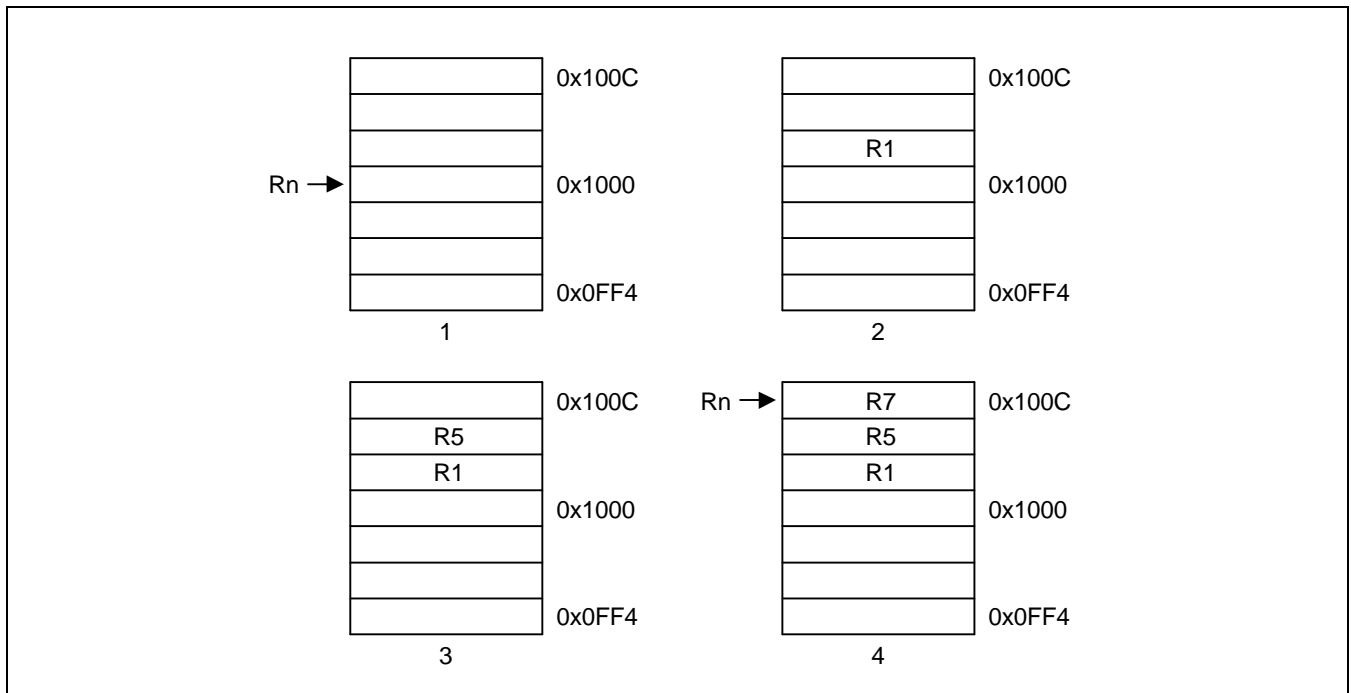

Figure 3-20. Pre-Increment Addressing

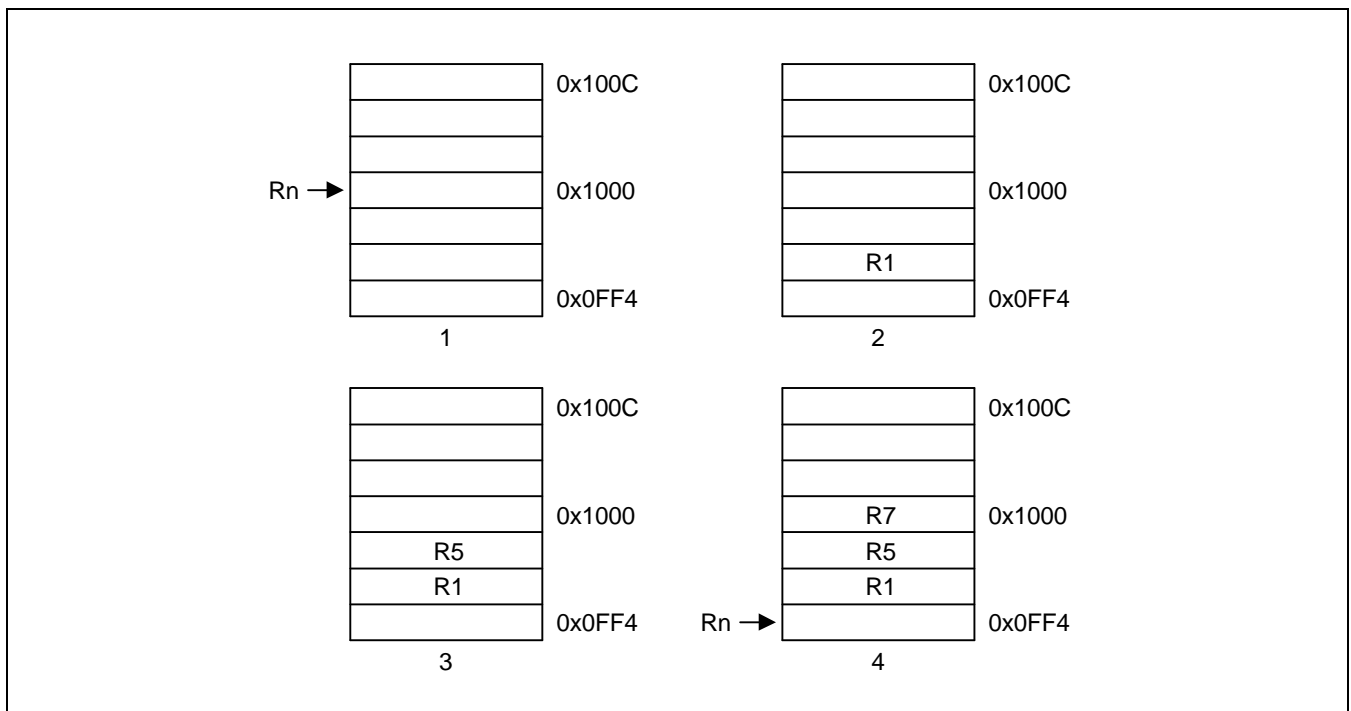

Figure 3-21. Post-Decrement Addressing

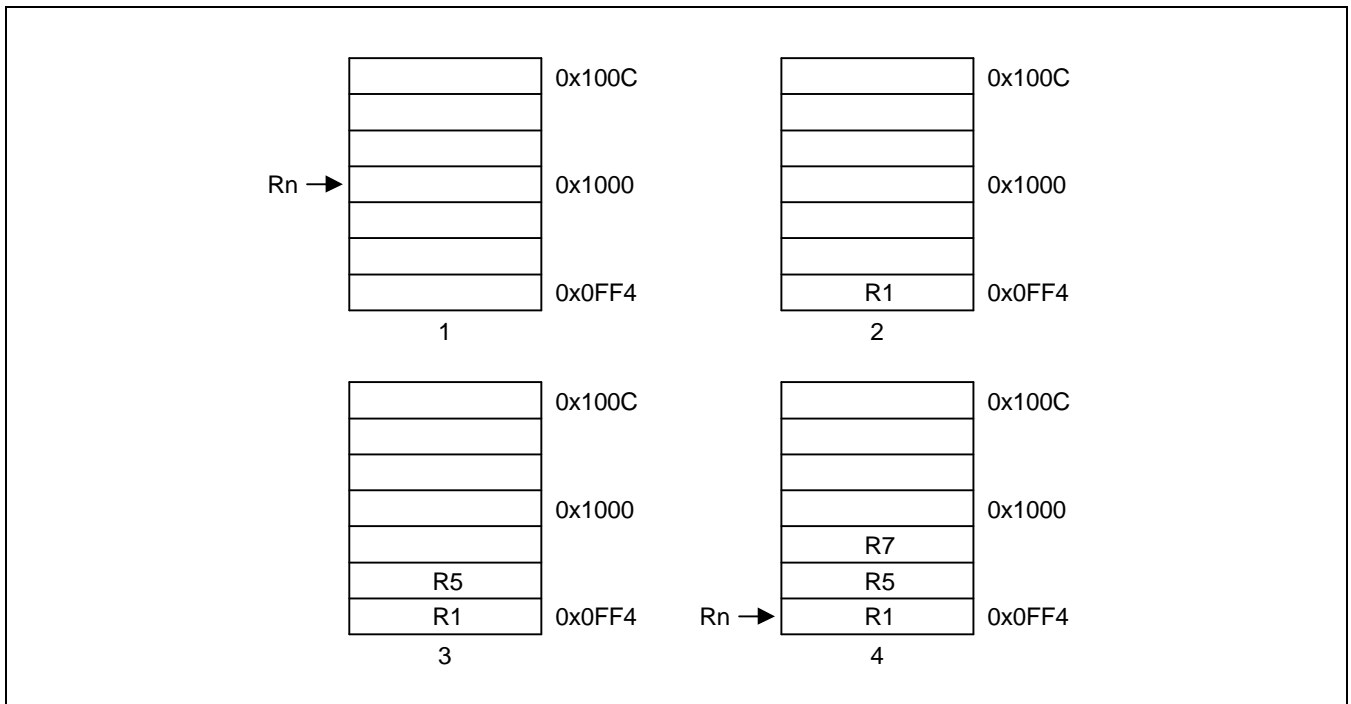

Figure 3-22. Pre-Decrement Addressing

### USE OF THE S BIT

When the S bit is set in a LDM/STM instruction its meaning depends on whether or not R15 is in the transfer list and on the type of instruction. The S bit should only be set if the instruction is to execute in a privileged mode.

#### LDM with R15 in Transfer List and S Bit Set (Mode Changes)

If the instruction is a LDM then SPSR\_<mode> is transferred to CPSR at the same time as R15 is loaded.

#### STM with R15 in Transfer List and S Bit Set (User Bank Transfer)

The registers transferred are taken from the user bank rather than the bank corresponding to the current mode. This is useful for saving the user state on process switches. Base write-back should not be used when this mechanism is employed.

#### R15 not in List and S Bit Set (User Bank Transfer)

For both LDM and STM instructions, the user bank registers are transferred rather than the register bank corresponding to the current mode. This is useful for saving the user state on process switches. Base write-back should not be used when this mechanism is employed.

When the instruction is LDM, care must be taken not to read from a banked register during the following cycle (inserting a dummy instruction such as MOV R0, R0 after the LDM will ensure safety).

### USE OF R15 AS THE BASE

R15 should not be used as the base register in any LDM or STM instruction.

## INCLUSION OF THE BASE IN THE REGISTER LIST

When write-back is specified, the base is written back at the end of the second cycle of the instruction. During a STM, the first register is written out at the start of the second cycle. A STM which includes storing the base, with the base as the first register to be stored, will therefore store the unchanged value, whereas with the base second or later in the transfer order, will store the modified value. A LDM will always overwrite the updated base if the base is in the list.

## DATA ABORTS

Some legal addresses may be unacceptable to a memory management system, and the memory manager can indicate a problem with an address by taking the abort signal high. This can happen on any transfer during a multiple register load or store, and must be recoverable if ARM7TDMI is to be used in a virtual memory system.

### Aborts during STM Instructions

If the abort occurs during a store multiple instruction, ARM7TDMI takes little action until the instruction completes, whereupon it enters the data abort trap. The memory manager is responsible for preventing erroneous writes to the memory. The only change to the internal state of the processor will be the modification of the base register if write-back was specified, and this must be reversed by software (and the cause of the abort resolved) before the instruction may be retried.

### Aborts during LDM Instructions

When ARM7TDMI detects a data abort during a load multiple instruction, it modifies the operation of the instruction to ensure that recovery is possible.

- Overwriting of registers stops when the abort happens. The aborting load will not take place but earlier ones may have overwritten registers. The PC is always the last register to be written and so will always be preserved.
- The base register is restored, to its modified value if write-back was requested. This ensures recoverability in the case where the base register is also in the transfer list, and may have been overwritten before the abort occurred.

The data abort trap is taken when the load multiple has completed, and the system software must undo any base modification (and resolve the cause of the abort) before restarting the instruction.

## INSTRUCTION CYCLE TIMES

Normal LDM instructions take  $nS + 1N + 1I$  and LDM PC takes  $(n+1)S + 2N + 1I$  incremental cycles, where S,N and I are defined as sequential (S-cycle), non-sequential (N-cycle), and internal (I-cycle), respectively. STM instructions take  $(n-1)S + 2N$  incremental cycles to execute, where  $n$  is the number of words transferred.

**ASSEMBLER SYNTAX**

<LDM|STM>{cond}<FD|ED|FA|EA|IA|IB|DA|DB> Rn{!},<Rlist>{^}

where:

{cond}	Two character condition mnemonic. See Table 3-2.
Rn	An expression evaluating to a valid register number
<Rlist>	A list of registers and register ranges enclosed in {} (e.g. {R0, R2–R7, R10}).
{!}	If present requests write-back (W = 1), otherwise W = 0.
{^}	If present set S bit to load the CPSR along with the PC, or force transfer of user bank when in privileged mode.

**Addressing Mode Names**

There are different assembler mnemonics for each of the addressing modes, depending on whether the instruction is being used to support stacks or for other purposes. The equivalence between the names and the values of the bits in the instruction are shown in the following table 3-6.

**Table 3-6. Addressing Mode Names**

Name	Stack	Other	L Bit	P Bit	U Bit
Pre-Increment load	LDMED	LDMIB	1	1	1
Post-Increment load	LDMFD	LDMIA	1	0	1
Pre-Decrement load	LDMEA	LDMDB	1	1	0
Post-Decrement load	LDMFA	LDMDA	1	0	0
Pre-Increment store	STMFA	STMIB	0	1	1
Post-Increment store	STMEA	STMIA	0	0	1
Pre-Decrement store	STMFD	STMDB	0	1	0
Post-Decrement store	STMED	STMDA	0	0	0

FD, ED, FA, EA define pre/post indexing and the up/down bit by reference to the form of stack required. The F and E refer to a "full" or "empty" stack, i.e. whether a pre-index has to be done (full) before storing to the stack. The A and D refer to whether the stack is ascending or descending. If ascending, a STM will go up and LDM down, if descending, vice-versa.

IA, IB, DA, DB allow control when LDM/STM are not being used for stacks and simply mean increment after, increment before, decrement after, decrement before.

**Examples**

```
LDMFD    SP!,{R0,R1,R2}    ; Unstack 3 registers.
STMIA    R0,{R0-R15}      ; Save all registers.
LDMFD    SP!,{R15}        ; R15 <- (SP), CPSR unchanged.
LDMFD    SP!,{R15}^       ; R15 <- (SP), CPSR <- SPSR_mode
                                     ; (allowed only in privileged modes).
STMFD    R13,{R0-R14}^    ; Save user mode regs on stack
                                     ; (allowed only in privileged modes).
```

These instructions may be used to save state on subroutine entry, and restore it efficiently on return to the calling routine:

```
STMED    SP!,{R0-R3,R14}  ; Save R0 to R3 to use as workspace
                                     ; and R14 for returning.
BL       somewhere        ; This nested call will overwrite R14
LDMED    SP!,{R0-R3,R15}  ; Restore workspace and return.
```



## SINGLE DATA SWAP (SWP)

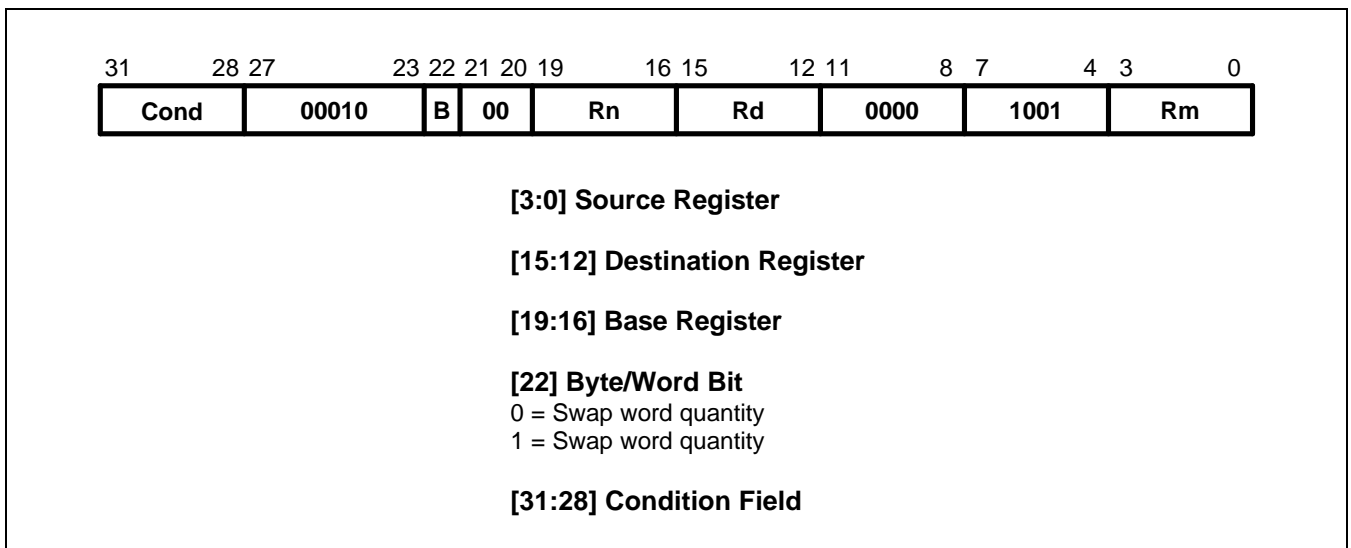

**Figure 3-23. Swap Instruction**

The instruction is only executed if the condition is true. The various conditions are defined in Table 3-2. The instruction encoding is shown in Figure 3-23.

The data swap instruction is used to swap a byte or word quantity between a register and external memory. This instruction is implemented as a memory read followed by a memory write which are “locked” together (the processor cannot be interrupted until both operations have completed, and the memory manager is warned to treat them as inseparable). This class of instruction is particularly useful for implementing software semaphores.

The swap address is determined by the contents of the base register (Rn). The processor first reads the contents of the swap address. Then it writes the contents of the source register (Rm) to the swap address, and stores the old memory contents in the destination register (Rd). The same register may be specified as both the source and destination.

The lock output goes HIGH for the duration of the read and write operations to signal to the external memory manager that they are locked together, and should be allowed to complete without interruption. This is important in multi-processor systems where the swap instruction is the only indivisible instruction which may be used to implement semaphores; control of the memory must not be removed from a processor while it is performing a locked operation.

### BYTES AND WORDS

This instruction class may be used to swap a byte (B = 1) or a word (B = 0) between an ARM7TDMI register and memory. The SWP instruction is implemented as a LDR followed by a STR and the action of these is as described in the section on single data transfers. In particular, the description of Big and Little Endian configuration applies to the SWP instruction.

### USE OF R15

Do not use R15 as an operand (Rd, Rn or Rs) in a SWP instruction.

## DATA ABORTS

If the address used for the swap is unacceptable to a memory management system, the memory manager can flag the problem by driving ABORT HIGH. This can happen on either the read or the write cycle (or both), and in either case, the data abort trap will be taken. It is up to the system software to resolve the cause of the problem, then the instruction can be restarted and the original program continued.

## INSTRUCTION CYCLE TIMES

Swap instructions take  $1S + 2N + I$  incremental cycles to execute, where S, N and I are defined as sequential (S-cycle), non-sequential, and internal (I-cycle), respectively.

## ASSEMBLER SYNTAX

<SWP>{cond}{B} Rd,Rm,[Rn]

{cond}	Two-character condition mnemonic. See Table 3-2.
{B}	If B is present then byte transfer, otherwise word transfer
Rd,Rm,Rn	Expressions evaluating to valid register numbers

### Examples

SWP	R0,R1,[R2]	; Load R0 with the word addressed by R2, and ; store R1 at R2.
SWPB	R2,R3,[R4]	; Load R2 with the byte addressed by R4, and ; store bits 0 to 7 of R3 at R4.
SWPEQ	R0,R0,[R1]	; Conditionally swap the contents of the ; word addressed by R1 with R0.

## SOFTWARE INTERRUPT (SWI)

The instruction is only executed if the condition is true. The various conditions are defined in Table 3-2. The instruction encoding is shown in Figure 3-24, below

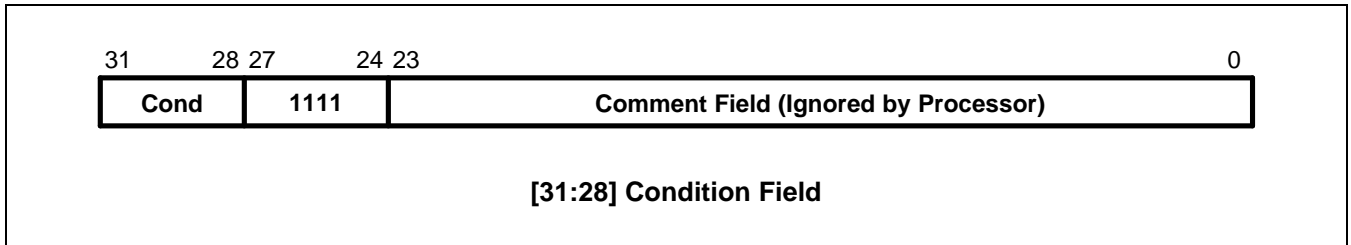

**Figure 3-24. Software Interrupt Instruction**

The software interrupt instruction is used to enter supervisor mode in a controlled manner. The instruction causes the software interrupt trap to be taken, which effects the mode change. The PC is then forced to a fixed value (0x08) and the CPSR is saved in SPSR\_svc. If the SWI vector address is suitably protected (by external memory management hardware) from modification by the user, a fully protected operating system may be constructed.

### RETURN FROM THE SUPERVISOR

The PC is saved in R14\_svc upon entering the software interrupt trap, with the PC adjusted to point to the word after the SWI instruction. MOVS PC,R14\_svc will return to the calling program and restore the CPSR.

Note that the link mechanism is not re-entrant, so if the supervisor code wishes to use software interrupts within itself it must first save a copy of the return address and SPSR.

### COMMENT FIELD

The bottom 24 bits of the instruction are ignored by the processor, and may be used to communicate information to the supervisor code. For instance, the supervisor may look at this field and use it to index into an array of entry points for routines which perform the various supervisor functions.

### INSTRUCTION CYCLE TIMES

Software interrupt instructions take  $2S + 1N$  incremental cycles to execute, where S and N are defined as sequential (S-cycle) and non-sequential (N-cycle).

**ASSEMBLER SYNTAX**

SWI{cond} &lt;expression&gt;

{cond} Two character condition mnemonic, Table 3-2.

&lt;expression&gt; Evaluated and placed in the comment field (which is ignored by ARM7TDMI).

**Examples**

```

SWI      ReadC           ; Get next character from read stream.
SWI      Writel+ "k"    ; Output a "k" to the write stream.
SWINE    0               ; Conditionally call supervisor with 0 in comment field.

```

**Supervisor code**

The previous examples assume that suitable supervisor code exists, for instance:

```

0x08 B Supervisor      ; SWI entry point
EntryTable             ; Addresses of supervisor routines
DCD ZeroRtn
DCD ReadCRtn
DCD WritelRtn
...
Zero EQU 0
ReadC EQU 256
Writel EQU 512
Supervisor             ; SWI has routine required in bits 8-23 and data (if any) in
                       ; bits 0-7. Assumes R13_svc points to a suitable stack
STMFD R13,{R0-R2,R14} ; Save work registers and return address.
LDR R0,[R14,#-4]       ; Get SWI instruction.
BIC R0,R0,#0xFF000000 ; Clear top 8 bits.
MOV R1,R0,LSR#8        ; Get routine offset.
ADR R2,EntryTable      ; Get start address of entry table.
LDR R15,[R2,R1,LSL#2] ; Branch to appropriate routine.
WritelRtn             ; Enter with character in R0 bits 0-7.
...
LDMFD R13,{R0-R2,R15}^ ; Restore workspace and return,
                       ; restoring processor mode and flags.

```

## COPROCESSOR DATA OPERATIONS (CDP)

The instruction is only executed if the condition is true. The various conditions are defined in Table 3-2. The instruction encoding is shown in Figure 3-25.

This class of instruction is used to tell a coprocessor to perform some internal operation. No result is communicated back to ARM7TDMI, and it will not wait for the operation to complete. The coprocessor could contain a queue of such instructions awaiting execution, and their execution can overlap other activity, allowing the coprocessor and ARM7TDMI to perform independent tasks in parallel.

### COPROCESSOR INSTRUCTIONS

The KS32C6200, unlike some other ARM-based processors, does not have an external coprocessor interface. It does not have a on-chip coprocessor also.

So then all coprocessor instructions will cause the undefined instruction trap to be taken on the KS32C6200. These coprocessor instructions can be emulated by the undefined trap handler. Even though external coprocessor can not be connected to the KS32C6200, the coprocessor instructions are still described here in full for completeness. (Remember that any external coprocessor described in this section is a software emulation.)

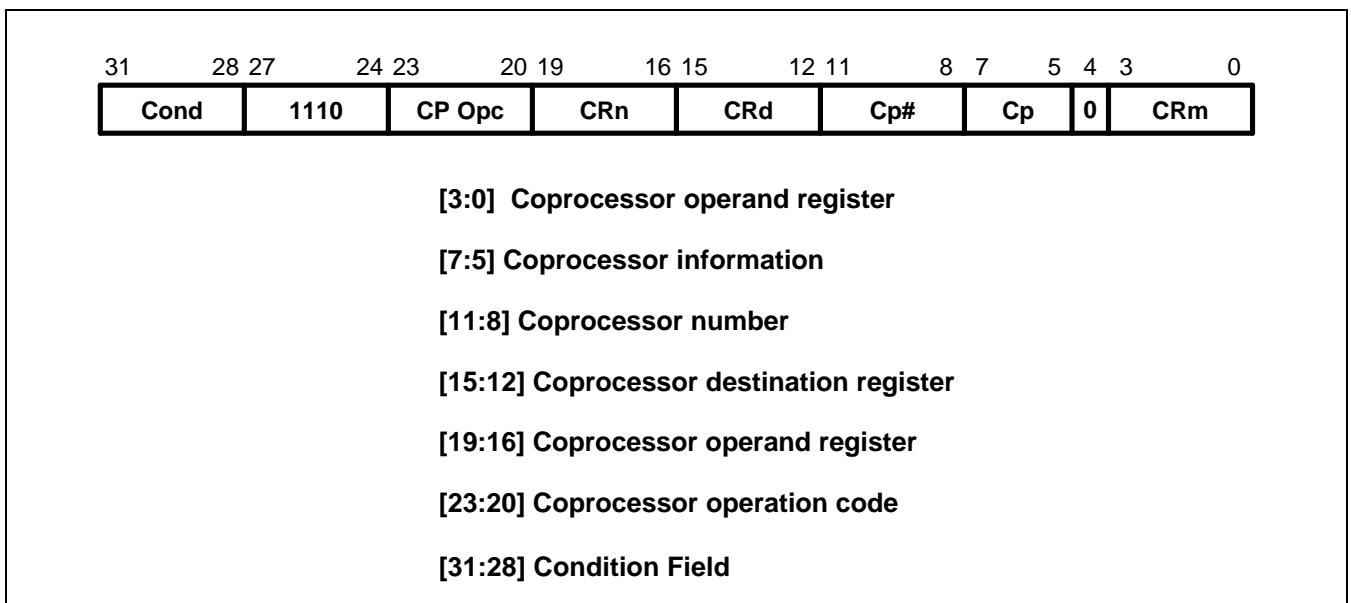

Figure 3-25. Coprocessor Data Operation Instruction

### THE COPROCESSOR FIELDS

Only bit 4 and bits 24 to 31 are significant to ARM7TDMI. The remaining bits are used by coprocessors. The above field names are used by convention, and particular coprocessors may redefine the use of all fields except CP# as appropriate. The CP# field is used to contain an identifying number (in the range 0 to 15) for each coprocessor, and a coprocessor will ignore any instruction which does not contain its number in the CP# field.

The conventional interpretation of the instruction is that the coprocessor should perform an operation specified in the CP Opc field (and possibly in the CP field) on the contents of CRn and CRm, and place the result in CRd.

**INSTRUCTION CYCLE TIMES**

Coprocessor data operations take  $1S + bI$  incremental cycles to execute, where  $b$  is the number of cycles spent in the coprocessor busy-wait loop.

$S$  and  $I$  are defined as sequential (S-cycle) and internal (I-cycle).

**ASSEMBLER SYNTAX**

$CDP\{cond\} p\#, <expression1>, cd, cn, cm\{, <expression2>\}$

$\{cond\}$	Two character condition mnemonic. See Table 3-2.
$p\#$	The unique number of the required coprocessor
$<expression1>$	Evaluated to a constant and placed in the CP Opc field
$cd, cn$ and $cm$	Evaluate to the valid coprocessor register numbers CRd, CRn and CRm respectively
$<expression2>$	Where present is evaluated to a constant and placed in the CP field

**Examples**

CDP	$p1, 10, c1, c2, c3$	; Request coproc 1 to do operation 10 ; on CR2 and CR3, and put the result in CR1.
CDPEQ	$p2, 5, c1, c2, c3, 2$	; If Z flag is set request coproc 2 to do operation 5 (type 2) ; on CR2 and CR3, and put the result in CR1.

## COPROCESSOR DATA TRANSFERS (LDC, STC)

The instruction is only executed if the condition is true. The various conditions are defined in Table 3-2. The instruction encoding is shown in Figure 3-26.

This class of instruction is used to load (LDC) or store (STC) a subset of a coprocessor's registers directly to memory. ARM7TDMI is responsible for supplying the memory address, and the coprocessor supplies or accepts the data and controls the number of words transferred.

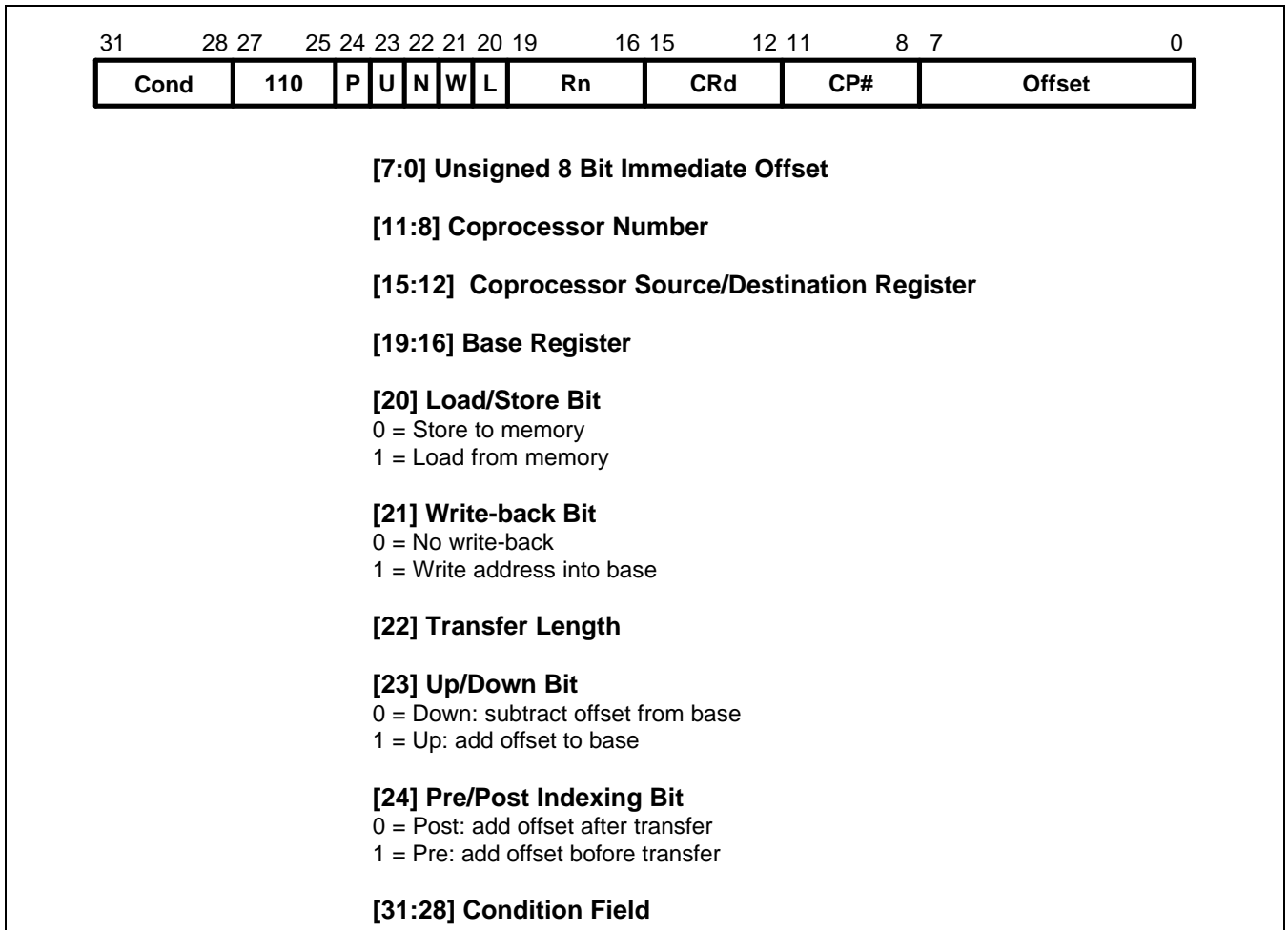

Figure 3-26. Coprocessor Data Transfer Instructions

### THE COPROCESSOR FIELDS

The CP# field is used to identify the coprocessor which is required to supply or accept the data, and a coprocessor will only respond if its number matches the contents of this field.

The CRd field and the N bit contain information for the coprocessor which may be interpreted in different ways by different coprocessors, but by convention CRd is the register to be transferred (or the first register where more than one is to be transferred), and the N bit is used to choose one of two transfer length options. For instance N = 0 could select the transfer of a single register, and N = 1 could select the transfer of all the registers for context switching.

## ADDRESSING MODES

ARM7TDMI is responsible for providing the address used by the memory system for the transfer, and the addressing modes available are a subset of those used in single data transfer instructions. Note, however, that the immediate offsets are 8 bits wide and specify word offsets for coprocessor data transfers, whereas they are 12 bits wide and specify byte offsets for single data transfers.

The 8 bit unsigned immediate offset is shifted left 2 bits and either added to ( $U = 1$ ) or subtracted from ( $U = 0$ ) the base register ( $R_n$ ); this calculation may be performed either before ( $P = 1$ ) or after ( $P = 0$ ) the base is used as the transfer address. The modified base value may be overwritten back into the base register (if  $W = 1$ ), or the old value of the base may be preserved ( $W = 0$ ). Note that post-indexed addressing modes require explicit setting of the  $W$  bit, unlike LDR and STR which always write-back when post-indexed.

The value of the base register, modified by the offset in a pre-indexed instruction, is used as the address for the transfer of the first word. The second word (if more than one is transferred) will go to or come from an address one word (4 bytes) higher than the first transfer, and the address will be incremented by one word for each subsequent transfer.

## ADDRESS ALIGNMENT

The base address should normally be a word aligned quantity. The bottom 2 bits of the address will appear on  $A[1:0]$  and might be interpreted by the memory system.

## USE OF R15

If  $R_n$  is R15, the value used will be the address of the instruction plus 8 bytes. Base write-back to R15 must not be specified.

## DATA ABORTS

If the address is legal but the memory manager generates an abort, the data trap will be taken. The write-back of the modified base will take place, but all other processor state will be preserved. The coprocessor is partly responsible for ensuring that the data transfer can be restarted after the cause of the abort has been resolved, and must ensure that any subsequent actions it undertakes can be repeated when the instruction is retried.

## INSTRUCTION CYCLE TIMES

Coprocessor data transfer instructions take  $(n-1)S + 2N + bI$  incremental cycles to execute, where:

- $n$                       The number of words transferred.
- $b$                       The number of cycles spent in the coprocessor busy-wait loop.

$S$ ,  $N$  and  $I$  are defined as sequential (S-cycle), non-sequential (N-cycle), and internal (I-cycle), respectively.



**ASSEMBLER SYNTAX**

<LDC|STC>{cond}{L} p#,cd,<Address>

LDC	Load from memory to coprocessor
STC	Store from coprocessor to memory
{L}	When present perform long transfer (N = 1), otherwise perform short transfer (N = 0)
{cond}	Two character condition mnemonic. See Table 3-2.
p#	The unique number of the required coprocessor
cd	An expression evaluating to a valid coprocessor register number that is placed in the CRd field

<Address> can be:

- 1 An expression which generates an address:  
The assembler will attempt to generate an instruction using the PC as a base and a corrected immediate offset to address the location given by evaluating the expression. This will be a PC relative, pre-indexed address. If the address is out of range, an error will be generated
- 2 A pre-indexed addressing specification:  
[Rn] offset of zero  
[Rn,<#expression>]{!} offset of <expression> bytes  
A post-indexed addressing specification:  
Rn,<#expression> offset of <expression> bytes  
{!} write back the base register (set the W bit) if ! is present  
Rn is an expression evaluating to a valid ARM7TDMI register number.

**NOTE**

If Rn is R15, the assembler will subtract 8 from the offset value to allow for ARM7TDMI pipelining.

**Examples**

LDC	p1,c2,table	; Load c2 of coproc 1 from address ; table, using a PC relative address.
STCEQL	p2,c3,[R5,#24]!	; Conditionally store c3 of coproc 2 ; into an address 24 bytes up from R5, ; write this address back to R5, and use ; long transfer option (probably to store multiple words).

**NOTE**

Although the address offset is expressed in bytes, the instruction offset field is in words. The assembler will adjust the offset appropriately.

## COPROCESSOR REGISTER TRANSFERS (MRC, MCR)

The instruction is only executed if the condition is true. The various conditions are defined in Table 3-2.. The instruction encoding is shown in Figure 3-27.

This class of instruction is used to communicate information directly between ARM7TDMI and a coprocessor. An example of a coprocessor to ARM7TDMI register transfer (MRC) instruction would be a FIX of a floating point value held in a coprocessor, where the floating point number is converted into a 32 bit integer within the coprocessor, and the result is then transferred to ARM7TDMI register. A FLOAT of a 32 bit value in ARM7TDMI register into a floating point value within the coprocessor illustrates the use of ARM7TDMI register to coprocessor transfer (MCR).

An important use of this instruction is to communicate control information directly from the coprocessor into the ARM7TDMI CPSR flags. As an example, the result of a comparison of two floating point values within a coprocessor can be moved to the CPSR to control the subsequent flow of execution.

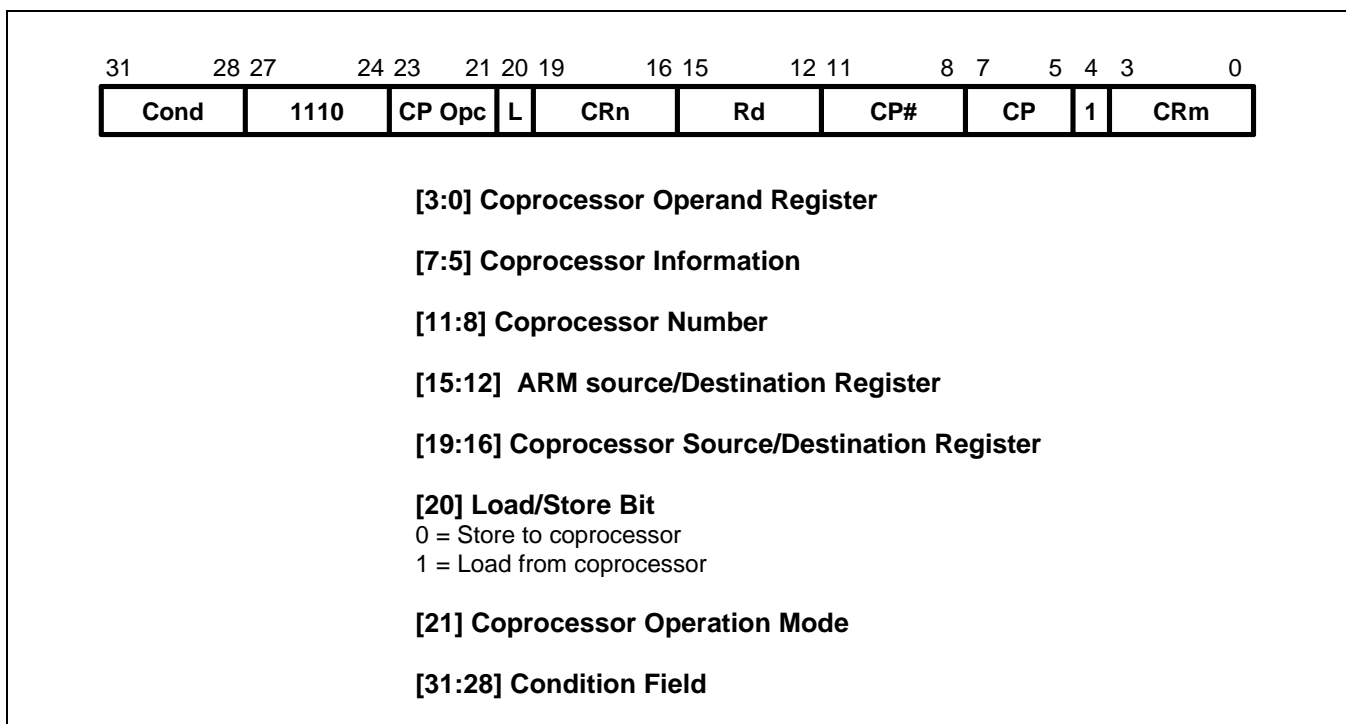

**Figure 3-27. Coprocessor Register Transfer Instructions**

### THE COPROCESSOR FIELDS

The CP# field is used, as for all coprocessor instructions, to specify which coprocessor is being called upon.

The CP Opc, CRn, CP and CRm fields are used only by the coprocessor, and the interpretation presented here is derived from convention only. Other interpretations are allowed where the coprocessor functionality is incompatible with this one. The conventional interpretation is that the CP Opc and CP fields specify the operation the coprocessor is required to perform, CRn is the coprocessor register which is the source or destination of the transferred information, and CRm is a second coprocessor register which may be involved in some way which depends on the particular operation specified.

## TRANSFERS TO R15

When a coprocessor register transfer to ARM7TDMI has R15 as the destination, bits 31, 30, 29 and 28 of the transferred word are copied into the N, Z, C and V flags respectively. The other bits of the transferred word are ignored, and the PC and other CPSR bits are unaffected by the transfer.

## TRANSFERS FROM R15

A coprocessor register transfer from ARM7TDMI with R15 as the source register will store the PC+ 12.

## INSTRUCTION CYCLE TIMES

MRC instructions take  $1S + (b+1)I + 1C$  incremental cycles to execute, where S, I and C are defined as sequential (S-cycle), internal (I-cycle), and coprocessor register transfer (C-cycle), respectively. MCR instructions take  $1S + bI + 1C$  incremental cycles to execute, where *b* is the number of cycles spent in the coprocessor busy-wait loop.

## ASSEMBLER SYNTAX

<MCR|MRC>{cond} p#,<expression1>,Rd,cn,cm{,<expression2>}

MRC	Move from coprocessor to ARM7TDMI register (L = 1)
MCR	Move from ARM7TDMI register to coprocessor (L = 0)
{cond}	Two character condition mnemonic. See Table 3-2.
p#	The unique number of the required coprocessor
<expression1>	Evaluated to a constant and placed in the CP Opc field
Rd	An expression evaluating to a valid ARM7TDMI register number
cn and cm	Expressions evaluating to the valid coprocessor register numbers CRn and CRm respectively
<expression2>	Where present is evaluated to a constant and placed in the CP field

## Examples

MRC	p2,5,R3,c5,c6	; Request coproc 2 to perform operation 5 ; on c5 and c6, and transfer the (single ; 32-bit word) result back to R3.
MCR	p6,0,R4,c5,c6	; Request coproc 6 to perform operation 0 ; on R4 and place the result in c6.
MRCEQ	p3,9,R3,c5,c6,2	; Conditionally request coproc 3 to ; perform operation 9 (type 2) on c5 and ; c6, and transfer the result back to R3.

## UNDEFINED INSTRUCTION

The instruction is only executed if the condition is true. The various conditions are defined in Table 3-2. The instruction format is shown in Figure 3-28.

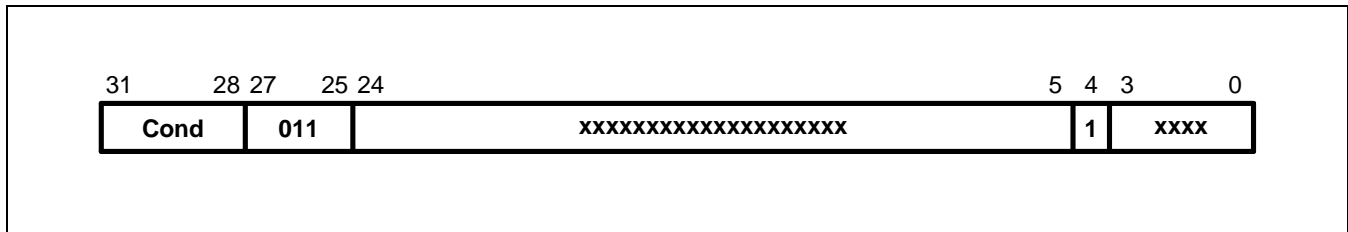

**Figure 3-28. Undefined Instruction**

If the condition is true, the undefined instruction trap will be taken.

Note that the undefined instruction mechanism involves offering this instruction to any coprocessors which may be present, and all coprocessors must refuse to accept it by driving CPA and CPB HIGH.

## INSTRUCTION CYCLE TIMES

This instruction takes  $2S + 1I + 1N$  cycles, where S, N and I are defined as sequential (S-cycle), non-sequential (N-cycle), and internal (I-cycle).

## ASSEMBLER SYNTAX

The assembler has no mnemonics for generating this instruction. If it is adopted in the future for some specified use, suitable mnemonics will be added to the assembler. Until such time, this instruction must not be used.

## INSTRUCTION SET EXAMPLES

The following examples show ways in which the basic ARM7TDMI instructions can combine to give efficient code. None of these methods saves a great deal of execution time (although they may save some), mostly they just save code.

### USING THE CONDITIONAL INSTRUCTIONS

#### Using Conditionals for Logical OR

```

CMP      Rn,#p           ; If Rn=p OR Rm=q THEN GOTO Label.
BEQ      Label
CMP      Rm,#q
BEQ      Label

```

This can be replaced by

```

CMP      Rn,#p           ; If condition not satisfied try other test.
CMPNE    Rm,#q
BEQ      Label

```

#### Absolute Value

```

TEQ      Rn,#0           ; Test sign
RSBMI    Rn,Rn,#0       ; and 2's complement if necessary.

```

#### Multiplication by 4, 5 or 6 (Run Time)

```

MOV      Rc,Ra,LSL#2    ; Multiply by 4,
CMP      Rb,#5          ; Test value,
ADDCS    Rc,Rc,Ra       ; Complete multiply by 5,
ADDHI    Rc,Rc,Ra       ; Complete multiply by 6.

```

#### Combining Discrete and Range Tests

```

TEQ      Rc,#127        ; Discrete test,
CMPNE    Rc,#"-1        ; Range test
MOVLS    Rc,#""         ; IF Rc<="" OR Rc=ASCII(127)
; THEN Rc=""

```

### Division and Remainder

A number of divide routines for specific applications are provided in source form as part of the ANSI C library provided with the ARM Cross development toolkit, available from your supplier. A short general purpose divide routine follows.

			; Enter with numbers in Ra and Rb.
	MOV	Rcnt,#1	; Bit to control the division.
Div1	CMP	Rb,#0x80000000	; Move Rb until greater than Ra.
	CMPCC	Rb,Ra	
	MOVCC	Rb,Rb,ASL#1	
	MOVCC	Rcnt,Rcnt,ASL#1	
	BCC	Div1	
	MOV	Rc,#0	
Div2	CMP	Ra,Rb	; Test for possible subtraction.
	SUBCS	Ra,Ra,Rb	; Subtract if ok,
	ADDCS	Rc,Rc,Rcnt	; Put relevant bit into result
	MOVS	Rcnt,Rcnt,LSR#1	; Shift control bit
	MOVNE	Rb,Rb,LSR#1	; Halve unless finished.
	BNE	Div2	; Divide result in Rc, remainder in Ra.

### Overflow Detection in the ARM7TDMI

#### 1. Overflow in unsigned multiply with a 32-bit result

	UMULL	Rd,Rt,Rm,Rn	; 3 to 6 cycles
	TEQ	Rt,#0	; +1 cycle and a register
	BNE	overflow	

#### 2. Overflow in signed multiply with a 32-bit result

	SMULL	Rd,Rt,Rm,Rn	; 3 to 6 cycles
	TEQ	Rt,Rd ASR#31	; +1 cycle and a register
	BNE	overflow	

#### 3. Overflow in unsigned multiply accumulate with a 32 bit result

	UMLAL	Rd,Rt,Rm,Rn	; 4 to 7 cycles
	TEQ	Rt,#0	; +1 cycle and a register
	BNE	overflow	

#### 4. Overflow in signed multiply accumulate with a 32 bit result

	SMLAL	Rd,Rt,Rm,Rn	; 4 to 7 cycles
	TEQ	Rt,Rd, ASR#31	; +1 cycle and a register
	BNE	overflow	

## 5. Overflow in unsigned multiply accumulate with a 64 bit result

UMULL	RI,Rh,Rm,Rn	; 3 to 6 cycles
ADDS	RI,RI,Ra1	; Lower accumulate
ADC	Rh,Rh,Ra2	; Upper accumulate
BCS	overflow	; 1 cycle and 2 registers

## 6. Overflow in signed multiply accumulate with a 64 bit result

SMULL	RI,Rh,Rm,Rn	; 3 to 6 cycles
ADDS	RI,RI,Ra1	; Lower accumulate
ADC	Rh,Rh,Ra2	; Upper accumulate
BVS	overflow	; 1 cycle and 2 registers

**NOTE**

Overflow checking is not applicable to unsigned and signed multiplies with a 64-bit result, since overflow does not occur in such calculations.

**PSEUDO-RANDOM BINARY SEQUENCE GENERATOR**

It is often necessary to generate (pseudo-) random numbers and the most efficient algorithms are based on shift generators with exclusive-OR feedback rather like a cyclic redundancy check generator. Unfortunately the sequence of a 32 bit generator needs more than one feedback tap to be maximal length (i.e.  $2^{32}-1$  cycles before repetition), so this example uses a 33 bit register with taps at bits 33 and 20. The basic algorithm is newbit: = bit 33 eor bit 20, shift left the 33 bit number and put in newbit at the bottom; this operation is performed for all the newbits needed (i.e. 32 bits). The entire operation can be done in 5 S cycles:

		; Enter with seed in Ra (32 bits),
		; Rb (1 bit in Rb lsb), uses Rc.
TST	Rb,Rb,LSR#1	; Top bit into carry
MOVS	Rc,Ra,RRX	; 33 bit rotate right
ADC	Rb,Rb,Rb	; Carry into lsb of Rb
EOR	Rc,Rc,Ra,LSL#12	; (involved!)
EOR	Ra,Rc,Rc,LSR#20	; (similarly involved!) new seed in Ra, Rb as before

**MULTIPLICATION BY CONSTANT USING THE BARREL SHIFTER****Multiplication by  $2^n$  (1,2,4,8,16,32..)**

MOV Ra, Rb, LSL #n

**Multiplication by  $2^{n+1}$  (3,5,9,17..)**

ADD Ra,Ra,Ra,LSL #n

**Multiplication by  $2^{n-1}$  (3,7,15..)**

RSB Ra,Ra,Ra,LSL #n

**Multiplication by 6**

```

ADD    Ra,Ra,Ra,LSL #1    ; Multiply by 3
MOV    Ra,Ra,LSL#1       ; and then by 2

```

**Multiply by 10 and add in extra number**

```

ADD    Ra,Ra,Ra,LSL#2     ; Multiply by 5
ADD    Ra,Rc,Ra,LSL#1     ; Multiply by 2 and add in next digit

```

**General recursive method for  $R_b := R_a * C$ ,  $C$  a constant:**

1. If  $C$  even, say  $C = 2^n * D$ ,  $D$  odd:

```

D=1:    MOV    Rb,Ra,LSL #n
D<>1:   {Rb := Ra*D}
MOV     Rb,Rb,LSL #n

```

2. If  $C \text{ MOD } 4 = 1$ , say  $C = 2^n * D + 1$ ,  $D$  odd,  $n > 1$ :

```

D=1:    ADD    Rb,Ra,Ra,LSL #n
D<>1:   {Rb := Ra*D}
ADD     Rb,Ra,Rb,LSL #n

```

3. If  $C \text{ MOD } 4 = 3$ , say  $C = 2^n * D - 1$ ,  $D$  odd,  $n > 1$ :

```

D=1:    RSB    Rb,Ra,Ra,LSL #n
D<>1:   {Rb := Ra*D}
RSB     Rb,Ra,Rb,LSL #n

```

This is not quite optimal, but close. An example of its non-optimality is multiply by 45 which is done by:

```

RSB     Rb,Ra,Ra,LSL#2     ; Multiply by 3
RSB     Rb,Ra,Rb,LSL#2     ; Multiply by  $4*3-1 = 11$ 
ADD     Rb,Ra,Rb,LSL# 2    ; Multiply by  $4*11+1 = 45$ 

```

rather than by:

```

ADD     Rb,Ra,Ra,LSL#3     ; Multiply by 9
ADD     Rb,Rb,Rb,LSL#2     ; Multiply by  $5*9 = 45$ 

```



## LOADING A WORD FROM AN UNKNOWN ALIGNMENT

BIC	Rb,Ra,#3	; Enter with address in Ra (32 bits) uses
LDMIA	Rb,{Rd,Rc}	; Rb, Rc result in Rd. Note d must be less than c e.g. 0,1
AND	Rb,Ra,#3	; Get word aligned address
MOVS	Rb,Rb,LSL#3	; Get 64 bits containing answer
MOVNE	Rd,Rd,LSR Rb	; Correction factor in bytes
RSBNE	Rb,Rb,#32	; ...now in bits and test if aligned
ORRNE	Rd,Rd,Rc,LSL Rb	; Produce bottom of result word (if not aligned)
		; Get other shift amount
		; Combine two halves to get result

## THUMB INSTRUCTION SET FORMAT

The thumb instruction sets are 16-bit versions of ARM instruction sets (32-bit format). The ARM instructions are reduced to 16-bit versions, Thumb instructions, at the cost of versatile functions of the ARM instruction sets. The thumb instructions are decompressed to the ARM instructions by the Thumb decompressor inside the ARM7TDMI core.

As the Thumb instructions are compressed ARM instructions, the Thumb instructions have the 16-bit format instructions and have some restrictions. The restrictions by 16-bit format is fully notified for using the Thumb instructions.

### FORMAT SUMMARY

The THUMB instruction set formats are shown in the following figure.

	15	14	13	12	11	10	9	8	7	6	5	4	3	2	1	0	
1	0	0	0	Op		Offset5					Rs	Rd					Move Shifted register
2	0	0	0	1	1	I	Op	Rn/offset3			Rs	Rd					Add/subtract
3	0	0	1	Op		Rd				Offset8							Move/compare/add/ subtract immediate
4	0	1	0	0	0	0	Op			Rs	Rd					ALU operations	
5	0	1	0	0	0	1	Op	H1	H2	Rs/Hs			Rd/Hd			Hi regiter operations /branch exchange	
6	0	1	0	0	1	Rd				Word8							PC-relative load
7	0	1	0	1	L	B	0	Ro			Rb	Rd				Load/store with register offset	
8	0	1	0	1	H	S	1	Ro			Rb	Rd				Load/store sign-extended byte/halfword	
9	0	1	1	B	L	Offset5					Rb	Rd				Load/store with immediate offset	
10	1	0	0	0	L	Offset5					Rb	Rd				Load/store halfword	
11	1	0	0	1	L	Rd				Word8							SP-relative load/store
12	1	0	1	0	SP	Rd				Word8							Load address
13	1	0	1	1	0	0	0	0	S	SWord7							Add offset to stack pointer
14	1	0	1	1	L	1	0	R	Rlist								Push/pop register
15	1	1	0	0	L	Rb				Rlist							Multiple load/store
16	1	1	0	1	Cond					Softset8							Conditional branch
17	1	1	0	1	1	1	1	Value8									Software interrupt
18	1	1	1	0	0	Offset11											Unconditional branch
19	1	1	1	1	H	Offset											Long branch with link

Figure 3-29. THUMB Instruction Set Formats

## OPCODE SUMMARY

The following table summarises the THUMB instruction set. For further information about a particular instruction please refer to the sections listed in the right-most column.

**Table 3-7. THUMB Instruction Set Opcodes**

Mnemonic	Instruction	Lo-Register Operand	Hi-Register Operand	Condition Codes Set
ADC	Add with carry	V	–	V
ADD	Add	V	V	V (1)
AND	AND	V	–	V
ASR	Arithmetic shift right	V	–	V
B	Unconditional branch	V	–	–
Bxx	Conditional branch	V	–	–
BIC	Bit clear	V	–	V
BL	Branch and link	V	–	–
BX	Branch and exchange	V	V	–
CMN	Compare negative	V	–	V
CMP	Compare	V	V	V
EOR	EOR	V	–	V
LDMIA	Load multiple	V	–	–
LDR	Load word	V	–	–
LDRB	Load byte	V	–	–
LDRH	Load half-word	V	–	–
LSL	Logical shift left	V	–	V
LDSB	Load sign-extended byte	V	–	–
LDSH	Load sign-extended half-word	V	–	–
LSR	Logical shift right	V	–	V
MOV	Move register	V	V	V (2)
MUL	Multiply	V	–	V
MVN	Move negative register	V	–	V
NEG	Negate	V	–	V
ORR	OR	V	–	V
POP	Pop registers	V	–	–
PUSH	Push registers	V	–	–
POR	Rotate right	V	–	V

Table 3-7. THUMB Instruction Set Opcodes (Continued)

Mnemonic	Instruction	Lo-Register Operand	Hi-Register Operand	Condition Codes Set
SBC	Subtract with carry	V	–	V
STMIA	Store multiple	V	–	–
STR	Store word	V	–	–
STRB	Store byte	V	–	–
STRH	Store half-word	V	–	–
SWI	Software interrupt	–	–	–
SUB	Subtract	V	–	V
TST	Test bits	V	–	V

**NOTES:**

1. The condition codes are unaffected by the format 5, 12 and 13 versions of this instruction.
2. The condition codes are unaffected by the format 5 version of this instruction.

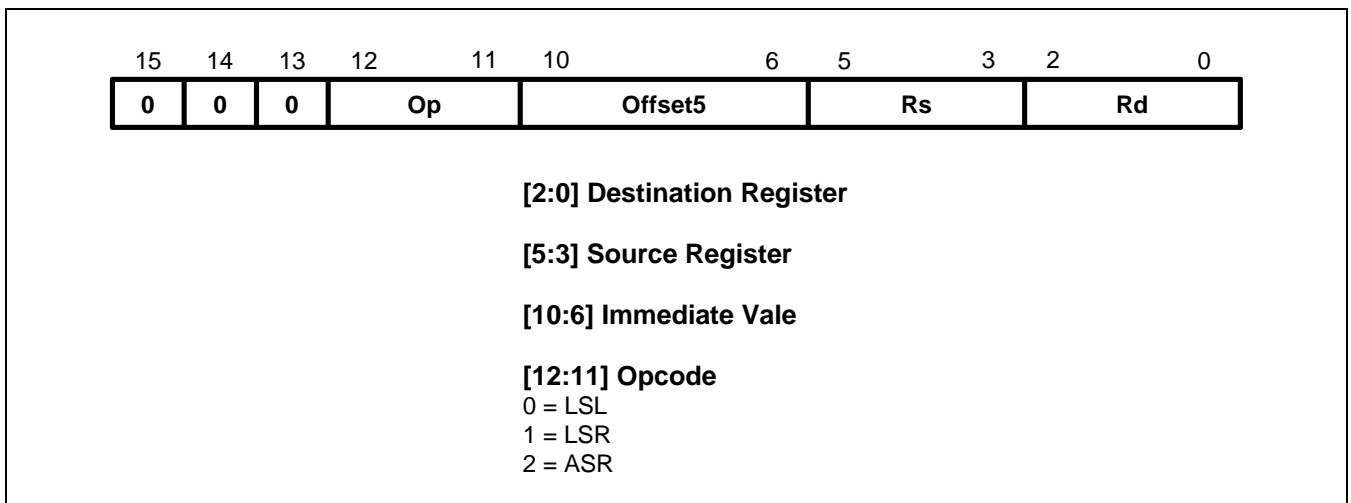
**FORMAT 1: MOVE SHIFTED REGISTER****Figure 3-30. Format 1****OPERATION**

These instructions move a shifted value between Lo registers. The THUMB assembler syntax is shown in Table 3-8.

**NOTE**

All instructions in this group set the CPSR condition codes.

**Table 3-8. Summary of Format 1 Instructions**

OP	THUMB Assembler	ARM Equivalent	Action
00	LSL Rd, Rs, #Offset5	MOVS Rd, Rs, LSL #Offset5	Shift Rs left by a 5-bit immediate value and store the result in Rd.
01	LSR Rd, Rs, #Offset5	MOVS Rd, Rs, LSR #Offset5	Perform logical shift right on Rs by a 5-bit immediate value and store the result in Rd.
10	ASR Rd, Rs, #Offset5	MOVS Rd, Rs, ASR #Offset5	Perform arithmetic shift right on Rs by a 5-bit immediate value and store the result in Rd.

**INSTRUCTION CYCLE TIMES**

All instructions in this format have an equivalent ARM instruction as shown in Table 3-8. The instruction cycle times for the THUMB instruction are identical to that of the equivalent ARM instruction.

**Examples**

```

LSR      R2, R5, #27      ; Logical shift right the contents
                          ; of R5 by 27 and store the result in R2.
                          ; Set condition codes on the result.
  
```

## FORMAT 2: ADD/SUBTRACT

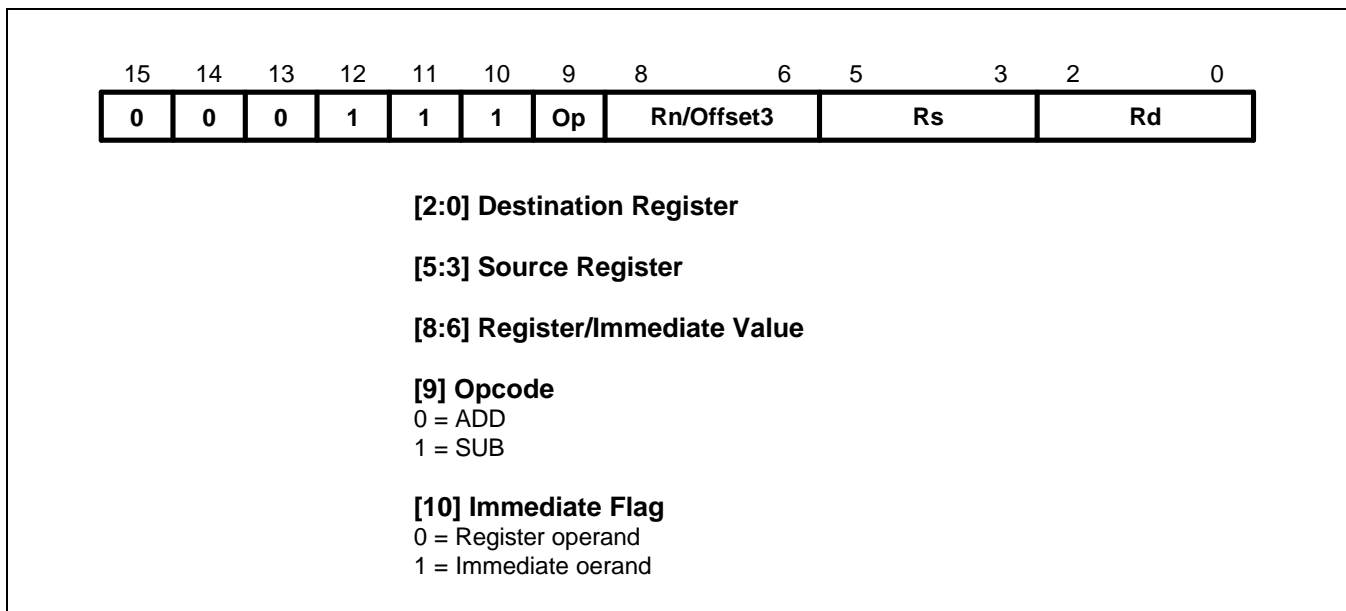

Figure 3-31. Format 2

## OPERATION

These instructions allow the contents of a Lo register or a 3-bit immediate value to be added to or subtracted from a Lo register. The THUMB assembler syntax is shown in Table 3-9.

## NOTE

All instructions in this group set the CPSR condition codes.

Table 3-9. Summary of Format 2 Instructions

OP	I	THUMB Assembler	ARM Equivalent	Action
0	0	ADD Rd, Rs, Rn	ADDS Rd, Rs, Rn	Add contents of Rn to contents of Rs. Place result in Rd.
0	1	ADD Rd, Rs, #Offset3	ADDS Rd, Rs, #Offset3	Add 3-bit immediate value to contents of Rs. Place result in Rd.
1	0	SUB Rd, Rs, Rn	SUBS Rd, Rs, Rn	Subtract contents of Rn from contents of Rs. Place result in Rd.
1	1	SUB Rd, Rs, #Offset3	SUBS Rd, Rs, #Offset3	Subtract 3-bit immediate value from contents of Rs. Place result in Rd.

**INSTRUCTION CYCLE TIMES**

All instructions in this format have an equivalent ARM instruction as shown in Table 3-9. The instruction cycle times for the THUMB instruction are identical to that of the equivalent ARM instruction.

**Examples**

ADD	R0, R3, R4	; R0 := R3 + R4 and set condition codes on the result.
SUB	R6, R2, #6	; R6 := R2 - 6 and set condition codes.

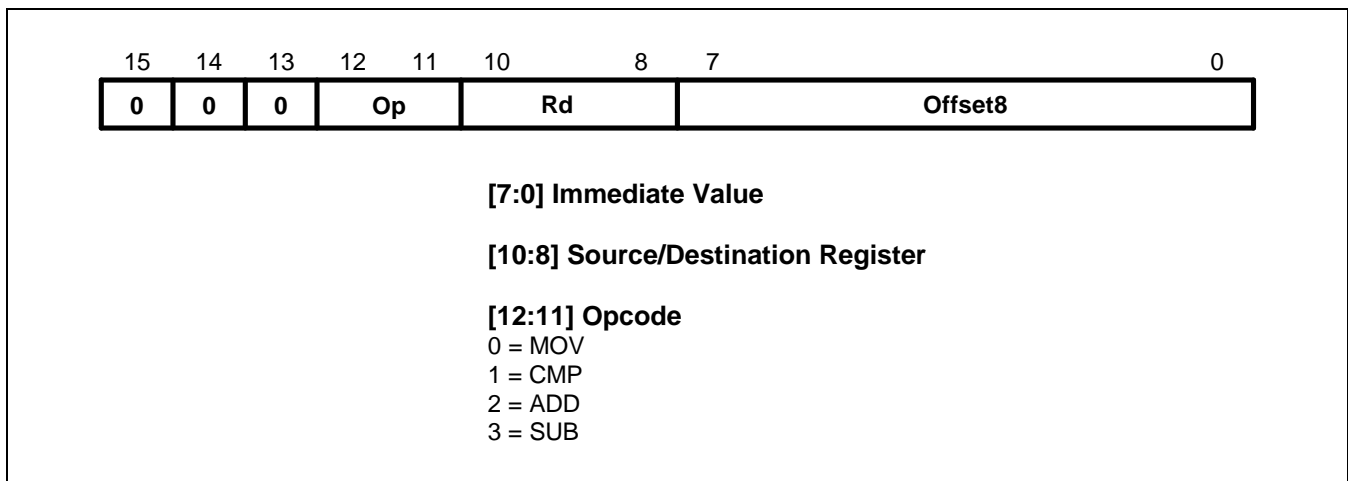
**FORMAT 3: MOVE/COMPARE/ADD/SUBTRACT IMMEDIATE****Figure 3-32. Format 3****OPERATIONS**

The instructions in this group perform operations between a Lo register and an 8-bit immediate value. The THUMB assembler syntax is shown in Table 3-10.

**NOTE**

All instructions in this group set the CPSR condition codes.

**Table 3-10. Summary of Format 3 Instructions**

OP	THUMB Assembler	ARM Equivalent	Action
00	MOV Rd, #Offset8	MOVS Rd, #Offset8	Move 8-bit immediate value into Rd.
01	CMP Rd, #Offset8	CMP Rd, #Offset8	Compare contents of Rd with 8-bit immediate value.
10	ADD Rd, #Offset8	ADDS Rd, Rd, #Offset8	Add 8-bit immediate value to contents of Rd and place the result in Rd.
11	SUB Rd, #Offset8	SUBS Rd, Rd, #Offset8	Subtract 8-bit immediate value from contents of Rd and place the result in Rd.

**INSTRUCTION CYCLE TIMES**

All instructions in this format have an equivalent ARM instruction as shown in Table 3-10. The instruction cycle times for the THUMB instruction are identical to that of the equivalent ARM instruction.

**Examples**

MOV	R0, #128	;	R0 := 128 and set condition codes
CMP	R2, #62	;	Set condition codes on R2 - 62
ADD	R1, #255	;	R1 := R1 + 255 and set condition codes
SUB	R6, #145	;	R6 := R6 - 145 and set condition codes



## FORMAT 4: ALU OPERATIONS

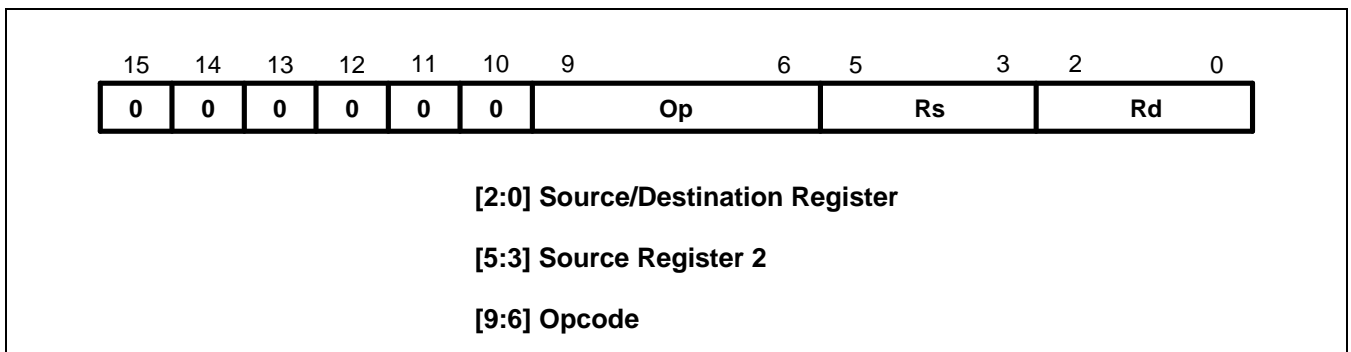

Figure 3-33. Format 4

### OPERATION

The following instructions perform ALU operations on a Lo register pair.

#### NOTE

All instructions in this group set the CPSR condition codes

Table 3-11. Summary of Format 4 Instructions

OP	THUMB Assembler	ARM Equivalent	Action
0000	AND Rd, Rs	ANDS Rd, Rd, Rs	Rd: = Rd AND Rs
0001	EOR Rd, Rs	EORS Rd, Rd, Rs	Rd: = Rd EOR Rs
0010	LSL Rd, Rs	MOVS Rd, Rd, LSL Rs	Rd : = Rd << Rs
0011	LSR Rd, Rs	MOVS Rd, Rd, LSR Rs	Rd : = Rd >> Rs
0100	ASR Rd, Rs	MOVS Rd, Rd, ASR Rs	Rd : = Rd ASR Rs
0101	ADC Rd, Rs	ADCS Rd, Rd, Rs	Rd : = Rd + Rs + C-bit
0110	SBC Rd, Rs	SBCS Rd, Rd, Rs	Rd : = Rd - Rs - NOT C-bit
0111	ROR Rd, Rs	MOVS Rd, Rd, ROR Rs	Rd : = Rd ROR Rs
1000	TST Rd, Rs	TST Rd, Rs	Set condition codes on Rd AND Rs
1001	NEG Rd, Rs	RSBS Rd, Rs, #0	Rd = - Rs
1010	CMP Rd, Rs	CMP Rd, Rs	Set condition codes on Rd - Rs
1011	CMN Rd, Rs	CMN Rd, Rs	Set condition codes on Rd + Rs
1100	ORR Rd, Rs	ORRS Rd, Rd, Rs	Rd: = Rd OR Rs
1101	MUL Rd, Rs	MULS Rd, Rs, Rd	Rd: = Rs * Rd
1110	BIC Rd, Rs	BICS Rd, Rd, Rs	Rd: = Rd AND NOT Rs
1111	MVN Rd, Rs	MVNS Rd, Rs	Rd: = NOT Rs

**INSTRUCTION CYCLE TIMES**

All instructions in this format have an equivalent ARM instruction as shown in Table 3-11. The instruction cycle times for the THUMB instruction are identical to that of the equivalent ARM instruction.

**Examples**

EOR	R3, R4	; R3 := R3 EOR R4 and set condition codes
ROR	R1, R0	; Rotate right R1 by the value in R0, store ; the result in R1 and set condition codes
NEG	R5, R3	; Subtract the contents of R3 from zero, ; store the result in R5. Set condition codes ie R5 = - R3
CMP	R2, R6	; Set the condition codes on the result of R2 - R6
MUL	R0, R7	; R0 := R7 * R0 and set condition codes

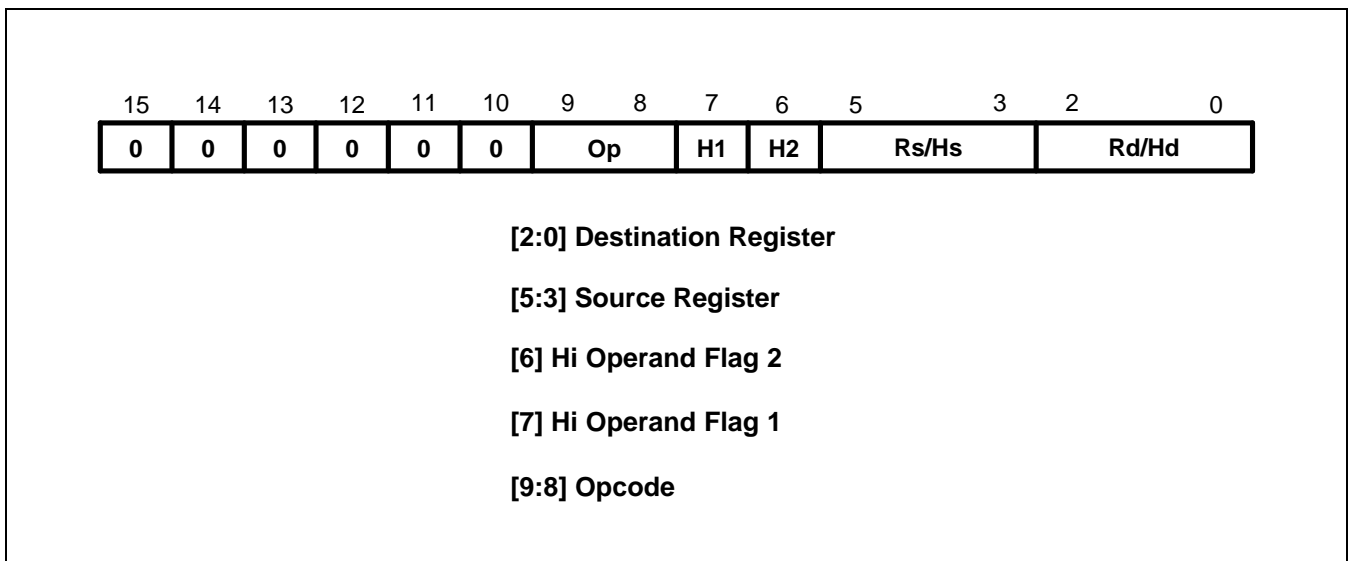
**FORMAT 5: HI-REGISTER OPERATIONS/BRANCH EXCHANGE****Figure 3-34. Format 5****OPERATION**

There are four sets of instructions in this group. The first three allow ADD, CMP and MOV operations to be performed between Lo and Hi registers, or a pair of Hi registers. The fourth, BX, allows a Branch to be performed which may also be used to switch processor state. The THUMB assembler syntax is shown in Table 3-12.

**NOTE**

In this group only CMP (Op = 01) sets the CPSR condition codes.

The action of H1 = 0, H2 = 0 for Op = 00 (ADD), Op = 01 (CMP) and Op = 10 (MOV) is undefined, and should not be used.

Table 3-12. Summary of Format 5 Instructions

OP	H1	H2	THUMB Assembler	ARM Equivalent	Action
00	0	1	ADD Rd, Hs	ADD Rd, Rd, Hs	Add a register in the range 8-15 to a register in the range 0-7.
00	1	0	ADD Hd, Rs	ADD Hd, Hd, Rs	Add a register in the range 0-7 to a register in the range 8-15.
00	1	1	ADD Hd, Hs	ADD Hd, Hd, Hs	Add two registers in the range 8-15.
01	0	1	CMP Rd, Hs	CMP Rd, Hs	Compare a register in the range 0-7 with a register in the range 8-15. Set the condition code flags on the result.
01	1	0	CMP Hd, Rs	CMP Hd, Rs	Compare a register in the range 8-15 with a register in the range 0-7. Set the condition code flags on the result.
01	1	1	CMP Hd, Hs	CMP Hd, Hs	Compare two registers in the range 8-15. Set the condition code flags on the result.
10	0	1	MOV Rd, Hs	MOV Rd, Hs	Move a value from a register in the range 8-15 to a register in the range 0-7.
10	1	0	MOV Hd, Rs	MOV Hd, Rs	Move a value from a register in the range 0-7 to a register in the range 8-15.
00	0	1	MOV Hd, Hs	MOV Hd, Hs	Move a value between two registers in the range 8-15.
00	1	0	BX Rs	BX Rs	Perform branch (plus optional state change) to address in a register in the range 0-7.
00	1	1	BX Hs	BX Hs	Perform branch (plus optional state change) to address in a register in the range 8-15.

### INSTRUCTION CYCLE TIMES

All instructions in this format have an equivalent ARM instruction as shown in Table 3-12. The instruction cycle times for the THUMB instruction are identical to that of the equivalent ARM instruction.

### THE BX INSTRUCTION

BX performs a branch to a routine whose start address is specified in a Lo or Hi register.

Bit 0 of the address determines the processor state on entry to the routine:

- Bit 0 = 0 Causes the processor to enter ARM state.
- Bit 0 = 1 Causes the processor to enter THUMB state.

### NOTE

The action of H1 = 1 for this instruction is undefined, and should not be used.

**Examples**

## Hi-Register Operations

```

ADD    PC, R5           ; PC := PC + R5 but don't set the condition codes.CMP
R4, R12                ; Set the condition codes on the result of R4 - R12.
MOV    R15, R14         ; Move R14 (LR) into R15 (PC)
                          ; but don't set the condition codes,
                          ; eg. return from subroutine.

```

## Branch and Exchange

```

ADR    R1,outofTHUMB    ; Switch from THUMB to ARM state.
MOV    R11,R1           ; Load address of outofTHUMB into R1.
BX    R11               ; Transfer the contents of R11 into the PC.
                          ; Bit 0 of R11 determines whether
                          ; ARM or THUMB state is entered, ie. ARM state here.

...
ALIGN
CODE32
outofTHUMB             ; Now processing ARM instructions...

```

**USING R15 AS AN OPERAND**

If R15 is used as an operand, the value will be the address of the instruction + 4 with bit 0 cleared. Executing a BX PC in THUMB state from a non-word aligned address will result in unpredictable execution.

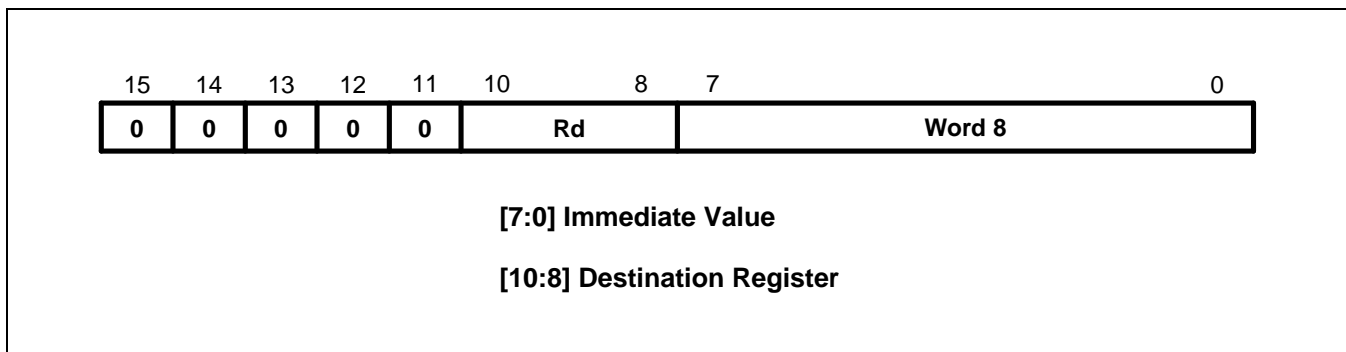
**FORMAT 6: PC-RELATIVE LOAD****Figure 3-35. Format 6****OPERATION**

This instruction loads a word from an address specified as a 10-bit immediate offset from the PC. The THUMB assembler syntax is shown below.

**Table 3-13. Summary of PC-Relative Load Instruction**

THUMB Assembler	ARM Equivalent	Action
LDR Rd, [PC, #Imm]	LDR Rd, [R15, #Imm]	Add unsigned offset (255 words, 1020 bytes) in Imm to the current value of the PC. Load the word from the resulting address into Rd.

**NOTE:** The value specified by #Imm is a full 10-bit address, but must always be word-aligned (ie with bits 1:0 set to 0), since the assembler places #Imm >> 2 in field Word 8. The value of the PC will be 4 bytes greater than the address of this instruction, but bit 1 of the PC is forced to 0 to ensure it is word aligned.

**INSTRUCTION CYCLE TIMES**

All instructions in this format have an equivalent ARM instruction. The instruction cycle times for the THUMB instruction are identical to that of the equivalent ARM instruction.

**Examples**

```
LDR R3,[PC,#844] ; Load into R3 the word found at the
                  ; address formed by adding 844 to PC.
                  ; bit[1] of PC is forced to zero.
                  ; Note that the THUMB opcode will contain
                  ; 211 as the Word8 value.
```

## FORMAT 7: LOAD/STORE WITH REGISTER OFFSET

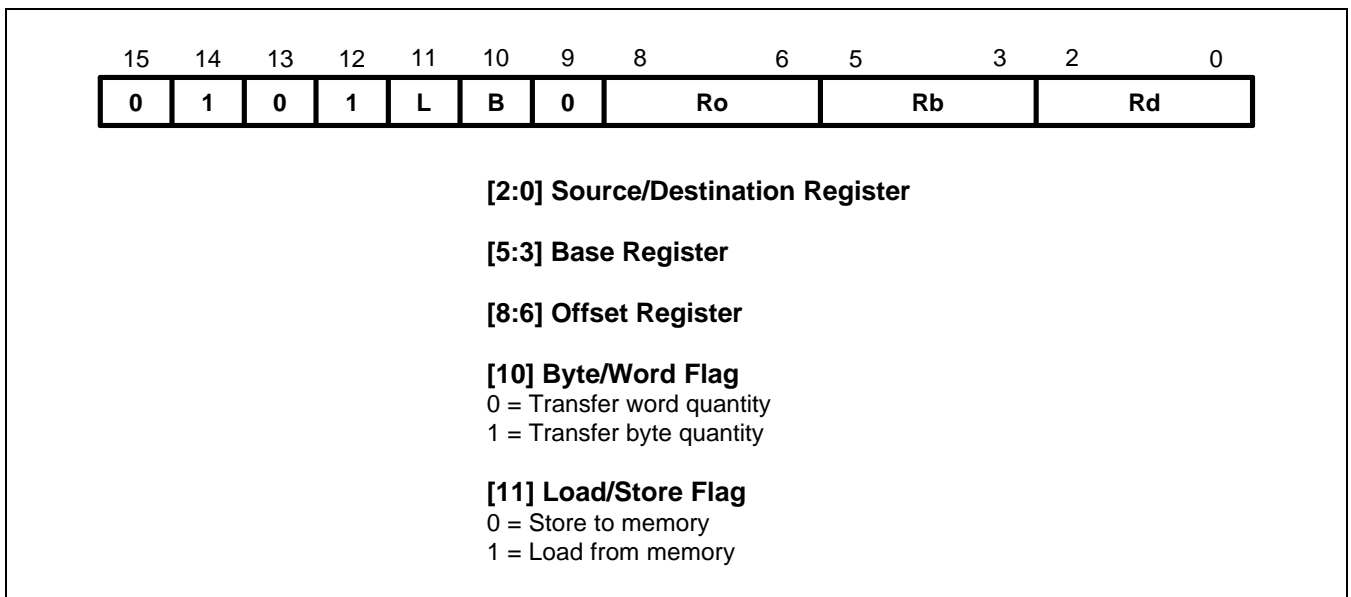

Figure 3-36. Format 7

### OPERATION

These instructions transfer byte or word values between registers and memory. Memory addresses are pre-indexed using an offset register in the range 0-7. The THUMB assembler syntax is shown in Table 3-14.

Table 3-14. Summary of Format 7 Instructions

L	B	THUMB Assembler	ARM Equivalent	Action
0	0	STR Rd, [Rb, Ro]	STR Rd, [Rb, Ro]	Pre-indexed word store: Calculate the target address by adding together the value in Rb and the value in Ro. Store the contents of Rd at the address.
0	1	STRB Rd, [Rb, Ro]	STRB Rd, [Rb, Ro]	Pre-indexed byte store: Calculate the target address by adding together the value in Rb and the value in Ro. Store the byte value in Rd at the resulting address.
1	0	LDR Rd, [Rb, Ro]	LDR Rd, [Rb, Ro]	Pre-indexed word load: Calculate the source address by adding together the value in Rb and the value in Ro. Load the contents of the address into Rd.
1	1	LDRB Rd, [Rb, Ro]	LDRB Rd, [Rb, Ro]	Pre-indexed byte load: Calculate the source address by adding together the value in Rb and the value in Ro. Load the byte value at the resulting address.

**INSTRUCTION CYCLE TIMES**

All instructions in this format have an equivalent ARM instruction as shown in Table 3-14. The instruction cycle times for the THUMB instruction are identical to that of the equivalent ARM instruction.

**Examples**

STR	R3, [R2,R6]	; Store word in R3 at the address ; formed by adding R6 to R2.
LDRB	R2, [R0,R7]	; Load into R2 the byte found at ; the address formed by adding R7 to R0.

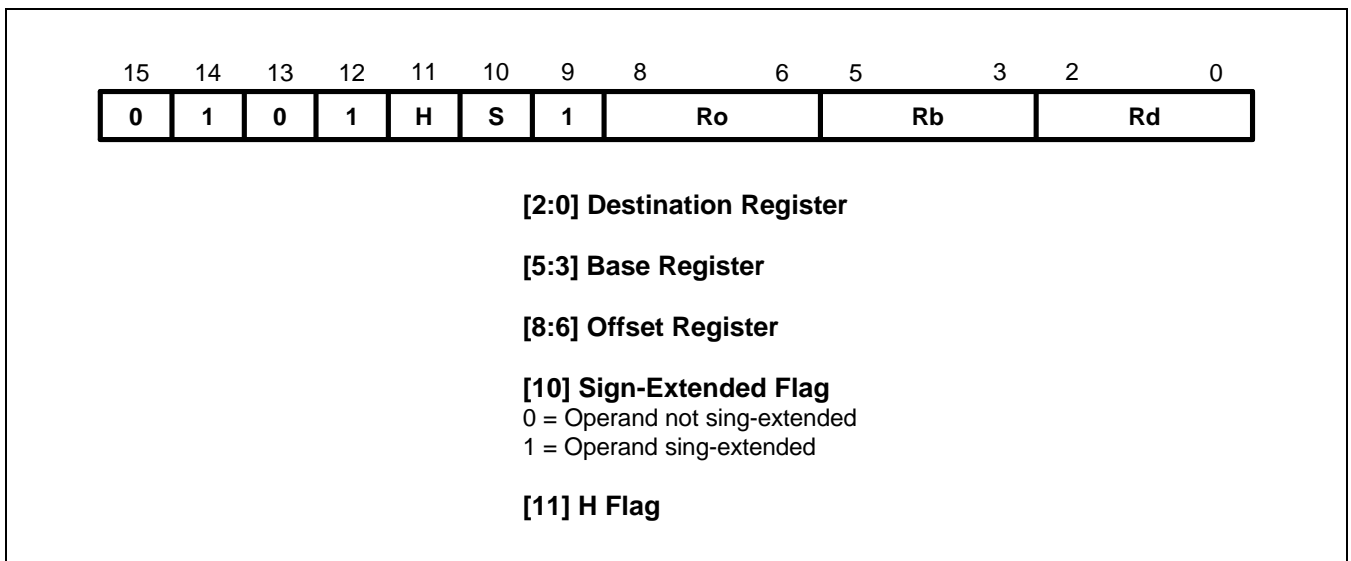

**FORMAT 8: LOAD/STORE SIGN-EXTENDED BYTE/HALF-WORD****Figure 3-37. Format 8****OPERATION**

These instructions load optionally sign-extended bytes or half-words, and store half-words. The THUMB assembler syntax is shown below.

**Table 3-15. Summary of format 8 instructions**

L	B	THUMB Assembler	ARM Equivalent	Action
0	0	STRH Rd, [Rb, Ro]	STRH Rd, [Rb, Ro]	Store half-word: Add Ro to base address in Rb. Store bits 0–15 of Rd at the resulting address.
0	1	LDRH Rd, [Rb, Ro]	LDRH Rd, [Rb, Ro]	Load half-word: Add Ro to base address in Rb. Load bits 0–15 of Rd from the resulting address, and set bits 16-31 of Rd to 0.
1	0	LDSB Rd, [Rb, Ro]	LDRSB Rd, [Rb, Ro]	Load sign-extended byte: Add Ro to base address in Rb. Load bits 0–7 of Rd from the resulting address, and set bits 8-31 of Rd to bit 7.
1	1	LDSH Rd, [Rb, Ro]	LDRSH Rd, [Rb, Ro]	Load sign-extended half-word: Add Ro to base address in Rb. Load bits 0–15 of Rd from the resulting address, and set bits 16-31 of Rd to bit 15.

**INSTRUCTION CYCLE TIMES**

All instructions in this format have an equivalent ARM instruction as shown in Table 3-15. The instruction cycle times for the THUMB instruction are identical to that of the equivalent ARM instruction.

**Examples**

STRH	R4, [R3, R0]	; Store the lower 16 bits of R4 at the
		; address formed by adding R0 to R3.
LDSB	R2, [R7, R1]	; Load into R2 the sign extended byte
		; found at the address formed by adding R1 to R7.
LDSH	R3, [R4, R2]	; Load into R3 the sign extended half-word
		; found at the address formed by adding R2 to R4.

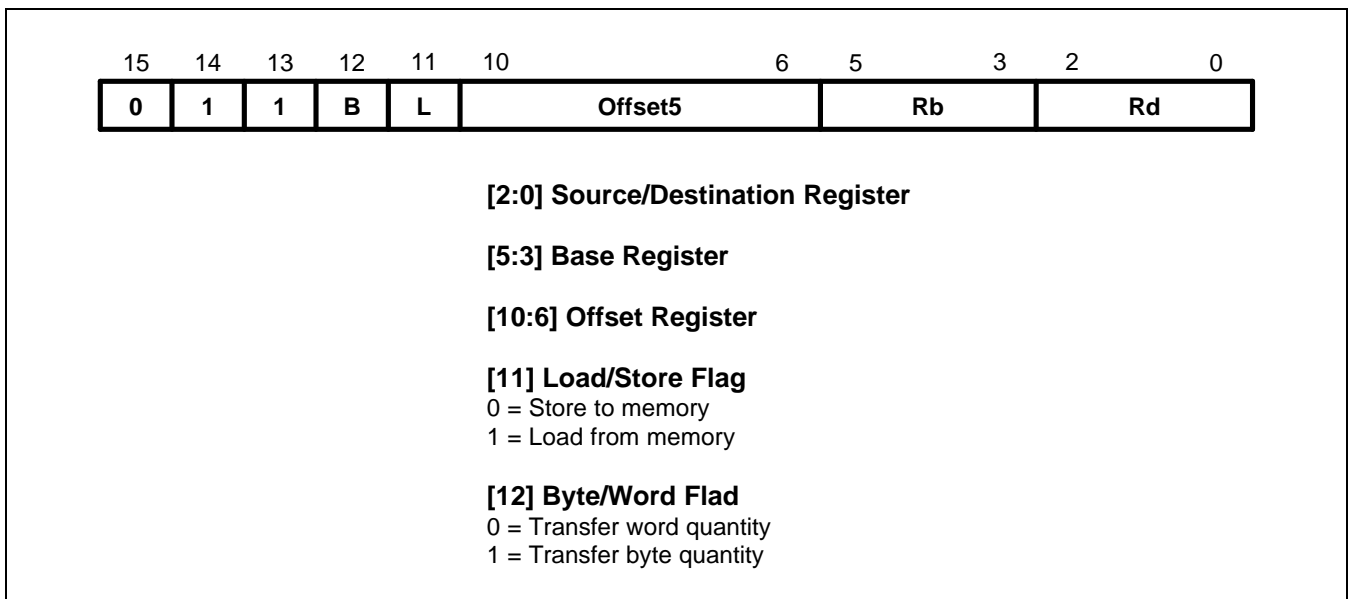
**FORMAT 9: LOAD/STORE WITH IMMEDIATE OFFSET****Figure 3-38. Format 9****OPERATION**

These instructions transfer byte or word values between registers and memory using an immediate 5 or 7-bit offset. The THUMB assembler syntax is shown in Table 3-16

**Table 3-16. Summary of Format 9 Instructions**

L	B	THUMB Assembler	ARM Equivalent	Action
0	0	STR Rd, [Rb, #Imm]	STR Rd, [Rb, #Imm]	Calculate the target address by adding together the value in Rb and Imm. Store the contents of Rd at the address.
0	1	LDR Rd, [Rb, #Imm]	LDR Rd, [Rb, #Imm]	Calculate the source address by adding together the value in Rb and Imm. Load Rd from the address.
1	0	STRB Rd, [Rb, #Imm]	STRB Rd, [Rb, #Imm]	Calculate the target address by adding together the value in Rb and Imm. Store the byte value in Rd at the address.
1	1	LDRB Rd, [Rb, #Imm]	LDRB Rd, [Rb, #Imm]	Calculate source address by adding together the value in Rb and Imm. Load the byte value at the address into Rd.

**NOTE:** For word accesses (B = 0), the value specified by #Imm is a full 7-bit address, but must be word-aligned (ie with bits 1:0 set to 0), since the assembler places #Imm >> 2 in the Offset5 field.

**INSTRUCTION CYCLE TIMES**

All instructions in this format have an equivalent ARM instruction as shown in Table 3-16. The instruction cycle times for the THUMB instruction are identical to that of the equivalent ARM instruction.

**Examples**

LDR	R2, [R5,#116]	; Load into R2 the word found at the ; address formed by adding 116 to R5. ; Note that the THUMB opcode will ; contain 29 as the Offset5 value.
STRB	R1, [R0,#13]	; Store the lower 8 bits of R1 at the ; address formed by adding 13 to R0. ; Note that the THUMB opcode will ; contain 13 as the Offset5 value.

## FORMAT 10: LOAD/STORE HALF-WORD

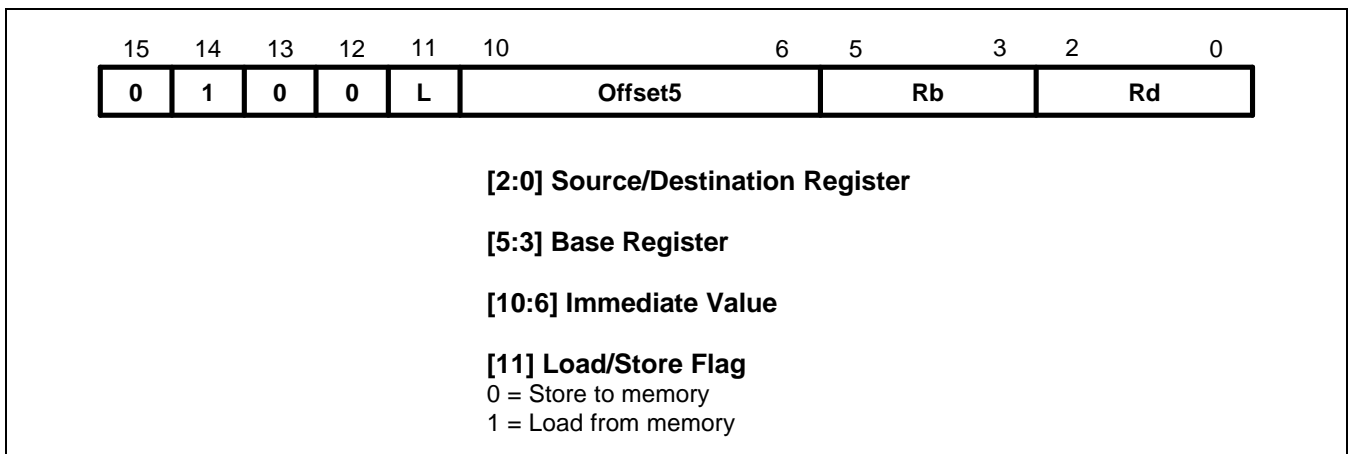

Figure 3-39. Format 10

### OPERATION

These instructions transfer half-word values between a Lo register and memory. Addresses are pre-indexed, using a 6-bit immediate value. The THUMB assembler syntax is shown in Table 3-17.

Table 3-17. Half-word Data Transfer Instructions

L	THUMB Assembler	ARM Equivalent	Action
0	STRH Rd, [Rb, #Imm]	STRH Rd, [Rb, #Imm]	Add #Imm to base address in Rb and store bits 0–15 of Rd at the resulting address.
1	LDRH Rd, [Rb, #Imm]	LDRH Rd, [Rb, #Imm]	Add #Imm to base address in Rb. Load bits 0–15 from the resulting address into Rd and set bits 16–31 to zero.

**NOTE:** #Imm is a full 6-bit address but must be half-word-aligned (ie with bit 0 set to 0), since the assembler places #Imm >> 1 in the Offset5 field.

### INSTRUCTION CYCLE TIMES

All instructions in this format have an equivalent ARM instruction as shown in Table 3-17. The instruction cycle times for the THUMB instruction are identical to that of the equivalent ARM instruction.

#### Examples

STRH	R6, [R1, #56]	; Store the lower 16 bits of R4 at the address formed by ; adding 56 R1. Note that the THUMB opcode will contain ; 28 as the Offset5 value.
LDRH	R4, [R7, #4]	; Load into R4 the half-word found at the address formed by ; adding 4 to R7. Note that the THUMB opcode will ; contain 2 as the Offset5 value.

## FORMAT 11: SP-RELATIVE LOAD/STORE

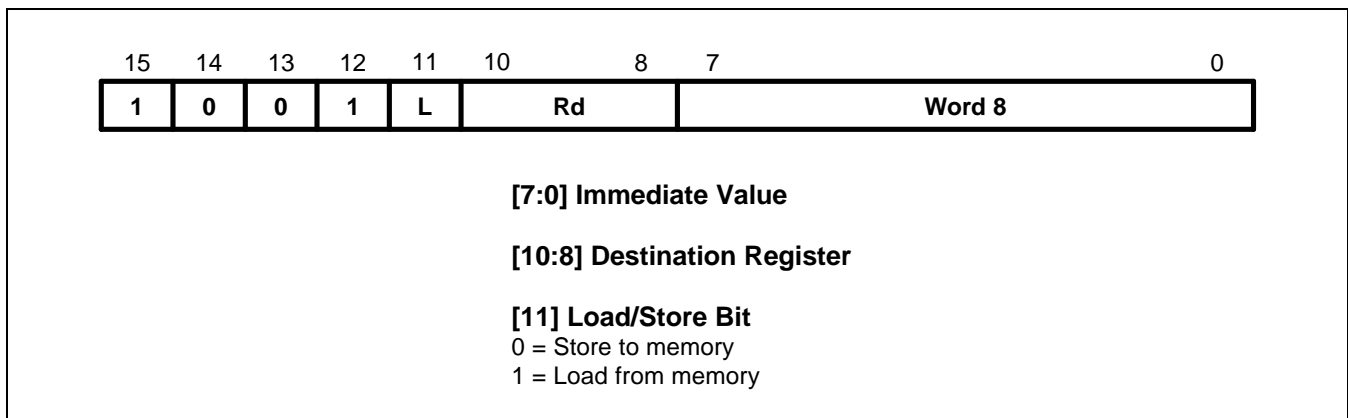

Figure 3-40. Format 11

### OPERATION

The instructions in this group perform an SP-relative load or store. The THUMB assembler syntax is shown in the following table.

Table 3-18. SP-Relative Load/Store Instructions

L	THUMB Assembler	ARM Equivalent	Action
0	STR Rd, [SP, #Imm]	STR Rd, [R13 #Imm]	Add unsigned offset (255 words, 1020 bytes) in Imm to the current value of the SP (R7). Store the contents of Rd at the resulting address.
1	LDR Rd, [SP, #Imm]	LDR Rd, [R13 #Imm]	Add unsigned offset (255 words, 1020 bytes) in Imm to the current value of the SP (R7). Load the word from the resulting address into Rd.

**NOTE:** The offset supplied in #Imm is a full 10-bit address, but must always be word-aligned (ie bits 1:0 set to 0), since the assembler places #Imm >> 2 in the Word8 field.

### INSTRUCTION CYCLE TIMES

All instructions in this format have an equivalent ARM instruction as shown in Table 3-18. The instruction cycle times for the THUMB instruction are identical to that of the equivalent ARM instruction.

#### Examples

```

STR      R4, [SP,#492]      ; Store the contents of R4 at the address
                                ; formed by adding 492 to SP (R13).
                                ; Note that the THUMB opcode will contain
                                ; 123 as the Word8 value.
  
```

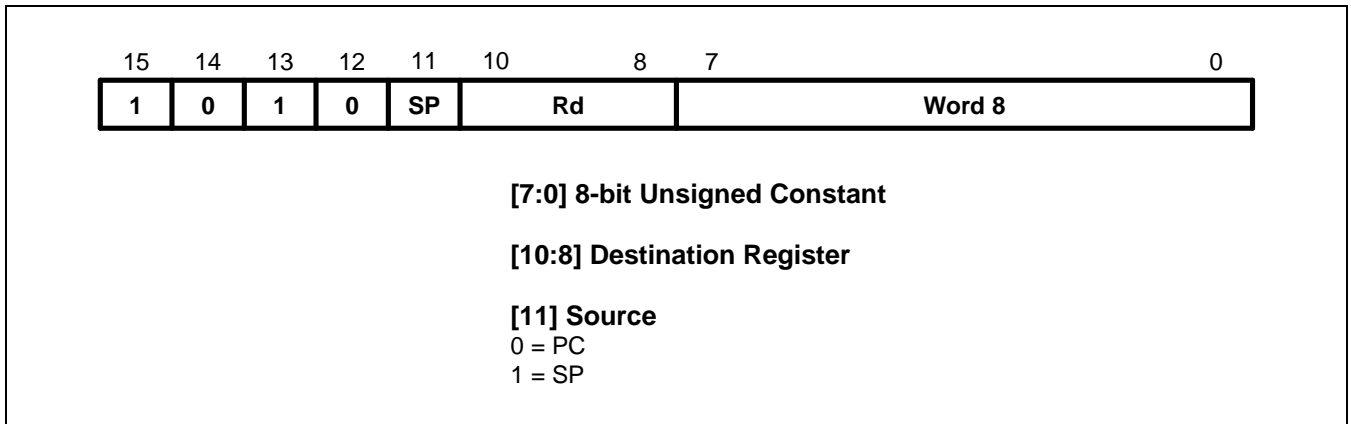
**FORMAT 12: LOAD ADDRESS****Figure 3-41. Format 12****OPERATION**

These instructions calculate an address by adding an 10-bit constant to either the PC or the SP, and load the resulting address into a register. The THUMB assembler syntax is shown in the following table.

**Table 3-19. Load Address**

SP	THUMB Assembler	ARM Equivalent	Action
0	ADD Rd, PC, #Imm	ADD Rd, R15, #Imm	Add #Imm to the current value of the program counter (PC) and load the result into Rd.
1	ADD Rd, SP, #Imm	ADD Rd, R13, #Imm	Add #Imm to the current value of the stack pointer (SP) and load the result into Rd.

**NOTE:** The value specified by #Imm is a full 10-bit value, but this must be word-aligned (ie with bits 1:0 set to 0) since the assembler places #Imm >> 2 in field Word 8.

Where the PC is used as the source register (SP = 0), bit 1 of the PC is always read as 0. The value of the PC will be 4 bytes greater than the address of the instruction before bit 1 is forced to 0.

The CPSR condition codes are unaffected by these instructions.

**INSTRUCTION CYCLE TIMES**

All instructions in this format have an equivalent ARM instruction as shown in Table 3-19. The instruction cycle times for the THUMB instruction are identical to that of the equivalent ARM instruction.

**Examples**

ADD	R2, PC, #572	; R2: = PC + 572, but don't set the ; condition codes. bit[1] of PC is forced to zero. ; Note that the THUMB opcode will ; contain 143 as the Word8 value.
ADD	R6, SP, #212	; R6: = SP (R13) + 212, but don't ; set the condition codes. ; Note that the THUMB opcode will ; contain 53 as the Word 8 value.



### FORMAT 13: ADD OFFSET TO STACK POINTER

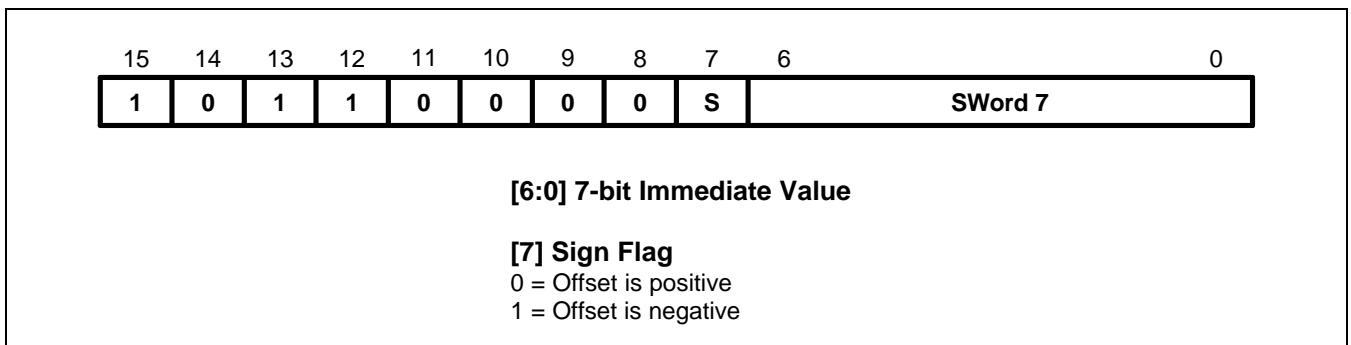

**Figure 3-42. Format 13**

### OPERATION

This instruction adds a 9-bit signed constant to the stack pointer. The following table shows the THUMB assembler syntax.

**Table 3-20. The ADD SP Instruction**

S	THUMB Assembler	ARM Equivalent	Action
0	ADD SP, #Imm	ADD R13, R13, #Imm	Add #Imm to the stack pointer (SP).
1	ADD SP, #-Imm	SUB R13, R13, #Imm	Add #-Imm to the stack pointer (SP).

**NOTE:** The offset specified by #Imm can be up to +/- 508, but must be word-aligned (ie with bits 1:0 set to 0) since the assembler converts #Imm to an 8-bit sign + magnitude number before placing it in field SWord7. The condition codes are not set by this instruction.

### INSTRUCTION CYCLE TIMES

All instructions in this format have an equivalent ARM instruction as shown in Table 3-20. The instruction cycle times for the THUMB instruction are identical to that of the equivalent ARM instruction.

### Examples

ADD	SP, #268	; SP (R13): = SP + 268, but don't set the condition codes. ; Note that the THUMB opcode will ; contain 67 as the Word7 value and S = 0.
ADD	SP, #-104	; SP (R13): = SP - 104, but don't set the condition codes. ; Note that the THUMB opcode will contain ; 26 as the Word7 value and S = 1.

## FORMAT 14: PUSH/POP REGISTERS

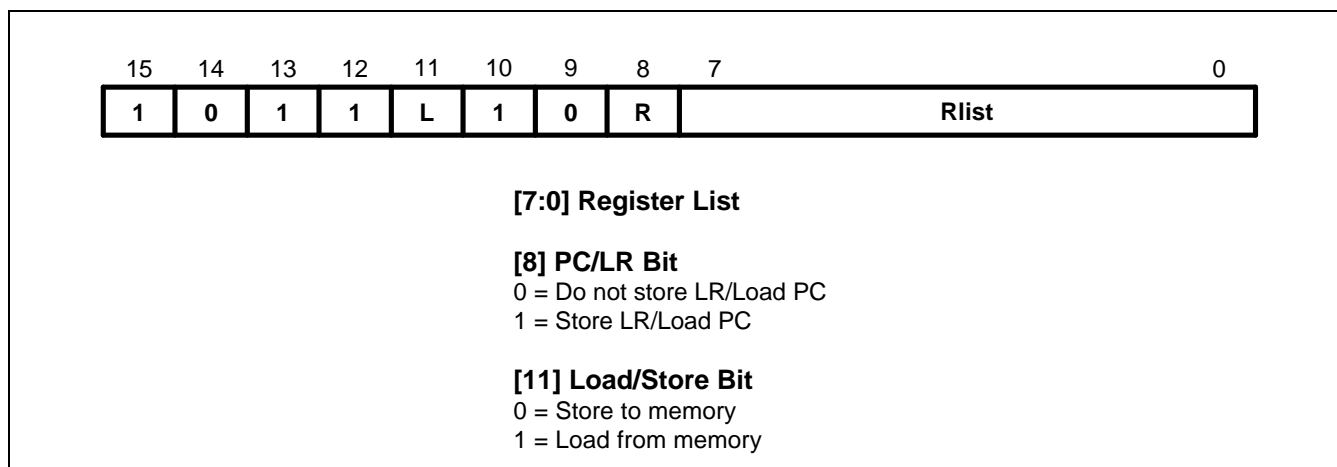

Figure 3-43. Format 14

## OPERATION

The instructions in this group allow registers 0-7 and optionally LR to be pushed onto the stack, and registers 0-7 and optionally PC to be popped off the stack. The THUMB assembler syntax is shown in Table 3-21.

## NOTE

The stack is always assumed to be full descending.

Table 3-21. PUSH and POP Instructions

L	B	THUMB Assembler	ARM Equivalent	Action
0	0	PUSH { Rlist }	STMDB R13!, { Rlist }	Push the registers specified by Rlist onto the stack. Update the stack pointer.
0	1	PUSH { Rlist, LR }	STMDB R13!, { Rlist, R14 }	Push the Link Register and the registers specified by Rlist (if any) onto the stack. Update the stack pointer.
1	0	POP { Rlist }	LDMIA R13!, { Rlist }	Pop values off the stack into the registers specified by Rlist. Update the stack pointer.
1	1	POP { Rlist, PC }	LDMIA R13!, { Rlist, R15 }	Pop values off the stack and load into the registers specified by Rlist. Pop the PC off the stack. Update the stack pointer.

**INSTRUCTION CYCLE TIMES**

All instructions in this format have an equivalent ARM instruction as shown in Table 3-21. The instruction cycle times for the THUMB instruction are identical to that of the equivalent ARM instruction.

**Examples**

PUSH	{R0–R4,LR}	; Store R0, R1, R2, R3, R4 and R14 (LR) at ; the stack pointed to by R13 (SP) and update R13. ; Useful at start of a sub-routine to ; save workspace and return address.
POP	{R2, R6, PC}	; Load R2, R6 and R15 (PC) from the stack ; pointed to by R13 (SP) and update R13. ; Useful to restore workspace and return from sub-routine.

## FORMAT 15: MULTIPLE LOAD/STORE

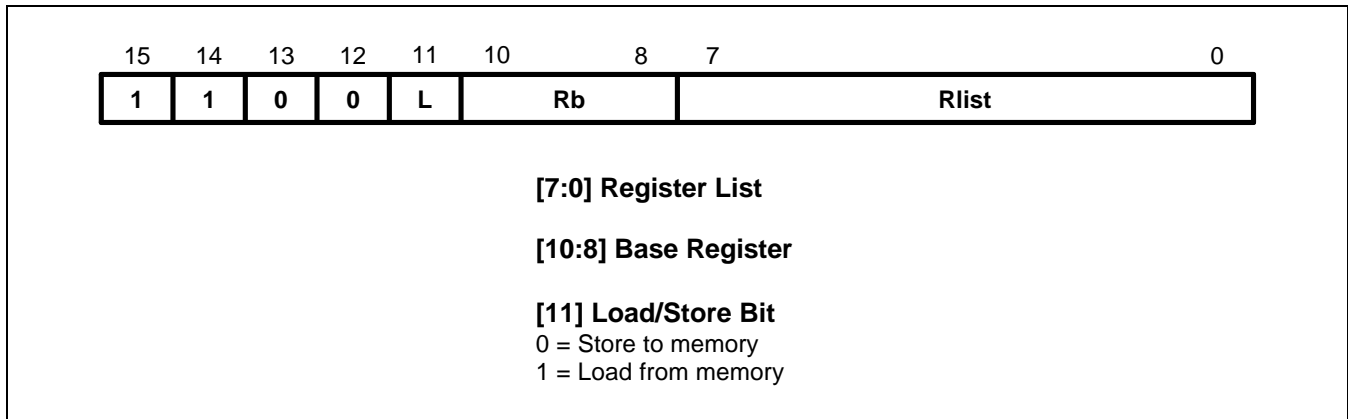

Figure 3-44. Format 15

## OPERATION

These instructions allow multiple loading and storing of Lo registers. The THUMB assembler syntax is shown in the following table.

Table 3-22. The Multiple Load/Store Instructions

L	THUMB Assembler	ARM Equivalent	Action
0	STMIA Rb!, { Rlist }	STMIA Rb!, { Rlist }	Store the registers specified by Rlist, starting at the base address in Rb. Write back the new base address.
1	LDMIA Rb!, { Rlist }	LDMIA Rb!, { Rlist }	Load the registers specified by Rlist, starting at the base address in Rb. Write back the new base address.

## INSTRUCTION CYCLE TIMES

All instructions in this format have an equivalent ARM instruction as shown in Table 3-22. The instruction cycle times for the THUMB instruction are identical to that of the equivalent ARM instruction.

## Examples

```

STMIA    R0!, {R3-R7}           ; Store the contents of registers R3-R7
                                     ; starting at the address specified in
                                     ; R0, incrementing the addresses for each word.
                                     ; Write back the updated value of R0.

```

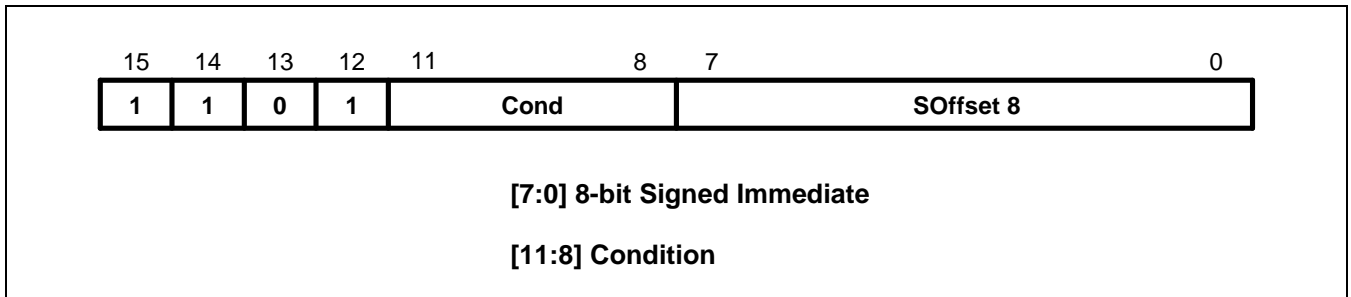
**FORMAT 16: CONDITIONAL BRANCH****Figure 3-45. Format 16****OPERATION**

The instructions in this group all perform a conditional Branch depending on the state of the CPSR condition codes. The branch offset must take account of the prefetch operation, which causes the PC to be 1 word (4 bytes) ahead of the current instruction.

The THUMB assembler syntax is shown in the following table.

**Table 3-23. The Conditional Branch Instructions**

Code	THUMB Assembler	ARM Equivalent	Action
0000	BEQ label	BEQ label	Branch if Z set (equal)
0001	BNE label	BNE label	Branch if Z clear (not equal)
0010	BCS label	BCS label	Branch if C set (unsigned higher or same)
0011	BCC label	BCC label	Branch if C clear (unsigned lower)
0100	BMI label	BMI label	Branch if N set (negative)
0101	BPL label	BPL label	Branch if N clear (positive or zero)
0110	BVS label	BVS label	Branch if V set (overflow)
0111	BVC label	BVC label	Branch if V clear (no overflow)
1000	BHI label	BHI label	Branch if C set and Z clear (unsigned higher)
1001	BLS label	BLS label	Branch if C clear or Z set (unsigned lower or same)
1010	BGE label	BGE label	Branch if N set and V set, or N clear and V clear (greater or equal)

Table 3-23. The Conditional Branch Instructions (Continued)

Code	THUMB Assembler	ARM Equivalent	Action
1011	BLT label	BLT label	Branch if N set and V clear, or N clear and V set (less than)
1100	BGT label	BGT label	Branch if Z clear, and either N set and V set or N clear and V clear (greater than)
1101	BLE label	BLE label	Branch if Z set, or N set and V clear, or N clear and V set (less than or equal)

**NOTES:**

1. While label specifies a full 9-bit two's complement address, this must always be half-word-aligned (ie with bit 0 set to 0) since the assembler actually places label >> 1 in field SOffset8.
2. Cond = 1110 is undefined, and should not be used.  
Cond = 1111 creates the SWI instruction: see .

**INSTRUCTION CYCLE TIMES**

All instructions in this format have an equivalent ARM instruction as shown in Table 3-23. The instruction cycle times for the THUMB instruction are identical to that of the equivalent ARM instruction.

**Examples**

```

        CMP R0, #45           ; Branch to over-if R0 > 45.
        BGT over             ; Note that the THUMB opcode will contain
        ...                 ; the number of half-words to offset.
        ...
over    ...                 ; Must be half-word aligned.
        ...

```

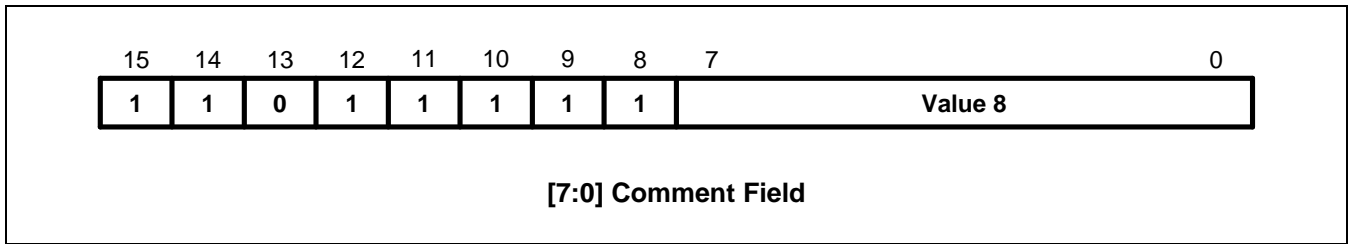
**FORMAT 17: SOFTWARE INTERRUPT****Figure 3-46. Format 17****OPERATION**

The SWI instruction performs a software interrupt. On taking the SWI, the processor switches into ARM state and enters Supervisor (SVC) mode.

The THUMB assembler syntax for this instruction is shown below.

**Table 3-24. The SWI Instruction**

THUMB Assembler	ARM Equivalent	Action
SWI Value 8	SWI Value 8	Perform Software Interrupt: Move the address of the next instruction into LR, move CPSR to SPSR, load the SWI vector address (0x8) into the PC. Switch to ARM state and enter SVC mode.

**NOTE:** Value 8 is used solely by the SWI handler; it is ignored by the processor.

**INSTRUCTION CYCLE TIMES**

All instructions in this format have an equivalent ARM instruction as shown in Table 3-24. The instruction cycle times for the THUMB instruction are identical to that of the equivalent ARM instruction.

**Examples**

```

SWI 18 ; Take the software interrupt exception.
       ; Enter Supervisor mode with 18 as the
       ; requested SWI number.

```

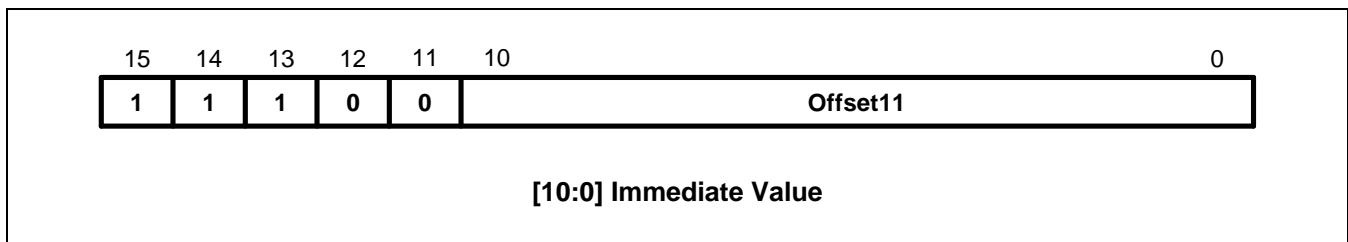
**FORMAT 18: UNCONDITIONAL BRANCH****Figure 3-47. Format 18****OPERATION**

This instruction performs a PC-relative Branch. The THUMB assembler syntax is shown below. The branch offset must take account of the prefetch operation, which causes the PC to be 1 word (4 bytes) ahead of the current instruction.

**Table 3-25. Summary of Branch Instruction**

THUMB Assembler	ARM Equivalent	Action
B label	BAL label (half-word offset)	Branch PC relative +/- Offset11 << 1, where label is PC +/- 2048 bytes.

**NOTE:** The address specified by label is a full 12-bit two's complement address, but must always be half-word aligned (ie bit 0 set to 0), since the assembler places label >> 1 in the Offset11 field.

**Examples**

```

here      B here          ; Branch onto itself. Assembles to 0xE7FE.
          ; (Note effect of PC offset).
          B jimmy         ; Branch to 'jimmy'.
          ...              ; Note that the THUMB opcode will contain the number of
          ; half-words to offset.
Jimmy    ...              ; Must be half-word aligned.

```

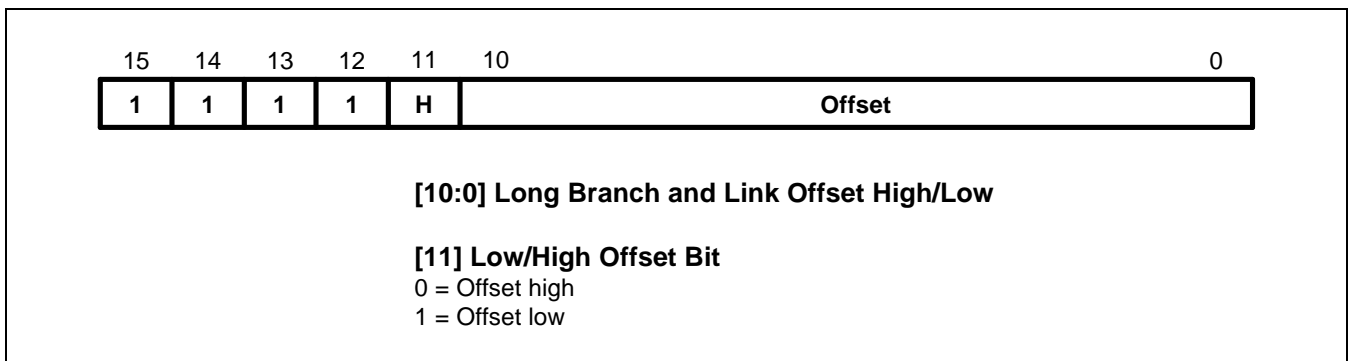

**FORMAT 19: LONG BRANCH WITH LINK****Figure 3-48. Format 19****OPERATION**

This format specifies a long branch with link.

The assembler splits the 23-bit two's complement half-word offset specified by the label into two 11-bit halves, ignoring bit 0 (which must be 0), and creates two THUMB instructions.

**Instruction 1 (H = 0)**

In the first instruction the Offset field contains the upper 11 bits of the target address. This is shifted left by 12 bits and added to the current PC address. The resulting address is placed in LR.

**Instruction 2 (H =1)**

In the second instruction the Offset field contains an 11-bit representation lower half of the target address. This is shifted left by 1 bit and added to LR. LR, which now contains the full 23-bit address, is placed in PC, the address of the instruction following the BL is placed in LR and bit 0 of LR is set.

The branch offset must take account of the prefetch operation, which causes the PC to be 1 word (4 bytes) ahead of the current instruction.

## INSTRUCTION CYCLE TIMES

This instruction format does not have an equivalent ARM instruction.

Table 3-26. The BL Instruction

H	THUMB Assembler	ARM Equivalent	Action
0	BL label	none	LR := PC + OffsetHigh << 12
1			temp := next instruction address PC := LR + OffsetLow << 1 LR := temp   1

## Examples

```

next      BL faraway      ; Unconditionally Branch to 'faraway'
           ...            ; and place following instruction
           ...            ; address, ie "next", in R14,the Link
           ...            ; register and set bit 0 of LR high.
           ...            ; Note that the THUMB opcodes will
faraway   ...            ; contain the number of half-words to offset.
           ...            ; Must be Half-word aligned.

```

## INSTRUCTION SET EXAMPLES

The following examples show ways in which the THUMB instructions may be used to generate small and efficient code. Each example also shows the ARM equivalent so these may be compared.

### MULTIPLICATION BY A CONSTANT USING SHIFTS AND ADDS

The following shows code to multiply by various constants using 1, 2 or 3 Thumb instructions alongside the ARM equivalents. For other constants it is generally better to use the built-in MUL instruction rather than using a sequence of 4 or more instructions.

Thumb	ARM
<b>1. Multiplication by <math>2^n</math> (1,2,4,8,...)</b>	
LSL        Ra, Rb, LSL #n	; MOV Ra, Rb, LSL #n
<b>2. Multiplication by <math>2^{n+1}</math> (3,5,9,17,...)</b>	
LSL        Rt, Rb, #n	; ADD Ra, Rb, Rb, LSL #n
ADD        Ra, Rt, Rb	
<b>3. Multiplication by <math>2^{n-1}</math> (3,7,15,...)</b>	
LSL        Rt, Rb, #n	; RSB Ra, Rb, Rb, LSL #n
SUB        Ra, Rt, Rb	
<b>4. Multiplication by <math>-2^n</math> (-2, -4, -8, ...)</b>	
LSL        Ra, Rb, #n	; MOV Ra, Rb, LSL #n
MVN        Ra, Ra	; RSB Ra, Ra, #0
<b>5. Multiplication by <math>-2^{n-1}</math> (-3, -7, -15, ...)</b>	
LSL        Rt, Rb, #n	; SUB Ra, Rb, Rb, LSL #n
SUB        Ra, Rb, Rt	

Multiplication by any  $C = \{2^{n+1}, 2^{n-1}, -2^n \text{ or } -2^{n-1}\} * 2^n$

Effectively this is any of the multiplications in 2 to 5 followed by a final shift. This allows the following additional constants to be multiplied. 6, 10, 12, 14, 18, 20, 24, 28, 30, 34, 36, 40, 48, 56, 60, 62 .....

(2..5)		; (2..5)
LSL        Ra, Ra, #n		; MOV Ra, Ra, LSL #n

**GENERAL PURPOSE SIGNED DIVIDE**

This example shows a general purpose signed divide and remainder routine in both Thumb and ARM code.

**Thumb code**

```

;signed_divide                                ; Signed divide of R1 by R0: returns quotient in R0,
                                              ; remainder in R1

;Get abs value of R0 into R3
    ASR    R2, R0, #31                        ; Get 0 or -1 in R2 depending on sign of R0
    EOR    R0, R2                             ; EOR with -1 (0xFFFFFFFF) if negative
    SUB    R3, R0, R2                         ; and ADD 1 (SUB -1) to get abs value

;SUB always sets flag so go & report division by 0 if necessary
    BEQ    divide_by_zero

;Get abs value of R1 by xoring with 0xFFFFFFFF and adding 1 if negative
    ASR    R0, R1, #31                        ; Get 0 or -1 in R3 depending on sign of R1
    EOR    R1, R0                             ; EOR with -1 (0xFFFFFFFF) if negative
    SUB    R1, R0                             ; and ADD 1 (SUB -1) to get abs value

;Save signs (0 or -1 in R0 & R2) for later use in determining ; sign of quotient & remainder.
    PUSH    {R0, R2}

;Justification, shift 1 bit at a time until divisor (R0 value) ; is just <= than dividend (R1 value). To do this shift
;dividend ; right by 1 and stop as soon as shifted value becomes >.
    LSR    R0, R1, #1
    MOV    R2, R3
    B      %FT0
just_l  LSL    R2, #1
0      CMP    R2, R0
    BLS    just_l
    MOV    R0, #0                            ; Set accumulator to 0
    B      %FT0                            ; Branch into division loop
div_l   LSR    R2, #1
0      CMP    R1, R2                        ; Test subtract
    BCC    %FT0
    SUB    R1, R2                            ; If successful do a real subtract
0      ADC    R0, R0                        ; Shift result and add 1 if subtract succeeded
    CMP    R2, R3                            ; Terminate when R2 == R3 (ie we have just
    BNE    div_l                            ; tested subtracting the 'ones' value).

;Now fix up the signs of the quotient (R0) and remainder (R1)
    POP    {R2, R3}                          ; Get dividend/divisor signs back
    EOR    R3, R2                            ; Result sign
    EOR    R0, R3                            ; Negate if result sign = -1
    SUB    R0, R3
    EOR    R1, R2                            ; Negate remainder if dividend sign = -1
    SUB    R1, R2
    MOV    pc, lr

```

**ARM Code**

```

signed_divide                                ; Effectively zero a4 as top bit will be shifted out later
        ANDS    a4, a1, #&80000000
        RSBMI   a1, a1, #0
        EORS    ip, a4, a2, ASR #32
;ip bit 31 = sign of result
;ip bit 30 = sign of a2
        RSBCS   a2, a2, #0

;Central part is identical code to udiv (without MOV a4, #0 which comes for free as part of signed entry sequence)
        MOVS    a3, a1
        BEQ     divide_by_zero

just_l                                       ; Justification stage shifts 1 bit at a time
        CMP     a3, a2, LSR #1
        MOVLS   a3, a3, LSL #1              ; NB: LSL #1 is always OK if LS succeeds
        BLO     s_loop

div_l
        CMP     a2, a3
        ADC     a4, a4, a4
        SUBCS   a2, a2, a3
        TEQ     a3, a1
        MOVNE   a3, a3, LSR #1
        BNE     s_loop2
        MOV     a1, a4
        MOVS    ip, ip, ASL #1
        RSBCS   a1, a1, #0
        RSBMI   a2, a2, #0
        MOV     pc, lr

```

**DIVISION BY A CONSTANT**

Division by a constant can often be performed by a short fixed sequence of shifts, adds and subtracts.

Here is an example of a divide by 10 routine based on the algorithm in the ARM Cookbook in both Thumb and ARM code.

**Thumb Code**

```

udiv10                                ; Take argument in a1 returns quotient in a1,
                                        ; remainder in a2
    MOV     a2, a1
    LSR     a3, a1, #2
    SUB     a1, a3
    LSR     a3, a1, #4
    ADD     a1, a3
    LSR     a3, a1, #8
    ADD     a1, a3
    LSR     a3, a1, #16
    ADD     a1, a3
    LSR     a1, #3
    ASL     a3, a1, #2
    ADD     a3, a1
    ASL     a3, #1
    SUB     a2, a3
    CMP     a2, #10
    BLT     %FT0
    ADD     a1, #1
    SUB     a2, #10
0
    MOV     pc, lr

```

**ARM Code**

```

udiv10                                ; Take argument in a1 returns quotient in a1,
                                        ; remainder in a2
    SUB     a2, a1, #10
    SUB     a1, a1, a1, lsr #2
    ADD     a1, a1, a1, lsr #4
    ADD     a1, a1, a1, lsr #8
    ADD     a1, a1, a1, lsr #16
    MOV     a1, a1, lsr #3
    ADD     a3, a1, a1, asl #2
    SUBS    a2, a2, a3, asl #1
    ADDPL   a1, a1, #1
    ADDMI   a2, a2, #10
    MOV     pc, lr

```

# 4 SYSTEM MANAGER

## OVERVIEW

The S3C4510B microcontroller's System Manager has the following functions.

- To arbitrate system bus access requests from several master blocks, based on fixed priorities.
- To provide the required memory control signals for external memory accesses. For example, if a master block such as the DMA controller or the CPU generates an address which corresponds to a DRAM bank, the System Manager's DRAM controller generates the required normal/EDO or SDRAM access signals. The interface signals for normal/EDO or SDRAM can be switched by SYSCFG[31].
- To provide the required signals for bus traffic between the S3C4510B and ROM/SRAM and the external I/O banks.
- To compensate for differences in bus width for data flowing between the external memory bus and the internal data bus.
- S3C4510B supports both little and big endian for external memory or I/O devices.

### NOTE

By generating an external bus request, an external device can access the S3C4510B's external memory interface pins. In addition, the S3C4510B can access slow external devices using a Wait signal. The Wait signal, which is generated by the external device, extends the duration of the CPU's memory access cycle beyond its programmable value.

## SYSTEM MANAGER REGISTERS

To control external memory operations, the System Manager uses a dedicated set of special registers (see Table 4-1). By programming the values in the System Manager special registers, you can specify such things as

- Memory type
- External bus width access cycle
- Control signal timing (RAS and CAS, for example)
- Memory bank locations
- The sizes of memory banks to be used for arbitrary address spacing

The System Manager uses special register settings to control the generation and processing of the control signals, addresses, and data that are required by external devices in a standard system configuration. Special registers are also used to control access to ROM/SRAM/Flash banks, up to four DRAM banks and four external I/O banks, and a special register mapping area.

The address resolution for each memory bank base pointer is 64K-bytes (16 bits). The base address pointer is 10 bits. This gives a total addressable memory bank space of 16 M words.

### NOTE

When writing a value to a memory bank control register from ROMCON0 to REFEXTCON (locations 0x3014 to 0x303C), as shown in Table 4-1, you must always set the register using a single STM (Store Multiple) instruction. Additionally, the address spaces for successive memory banks must not overlap in the system memory map.



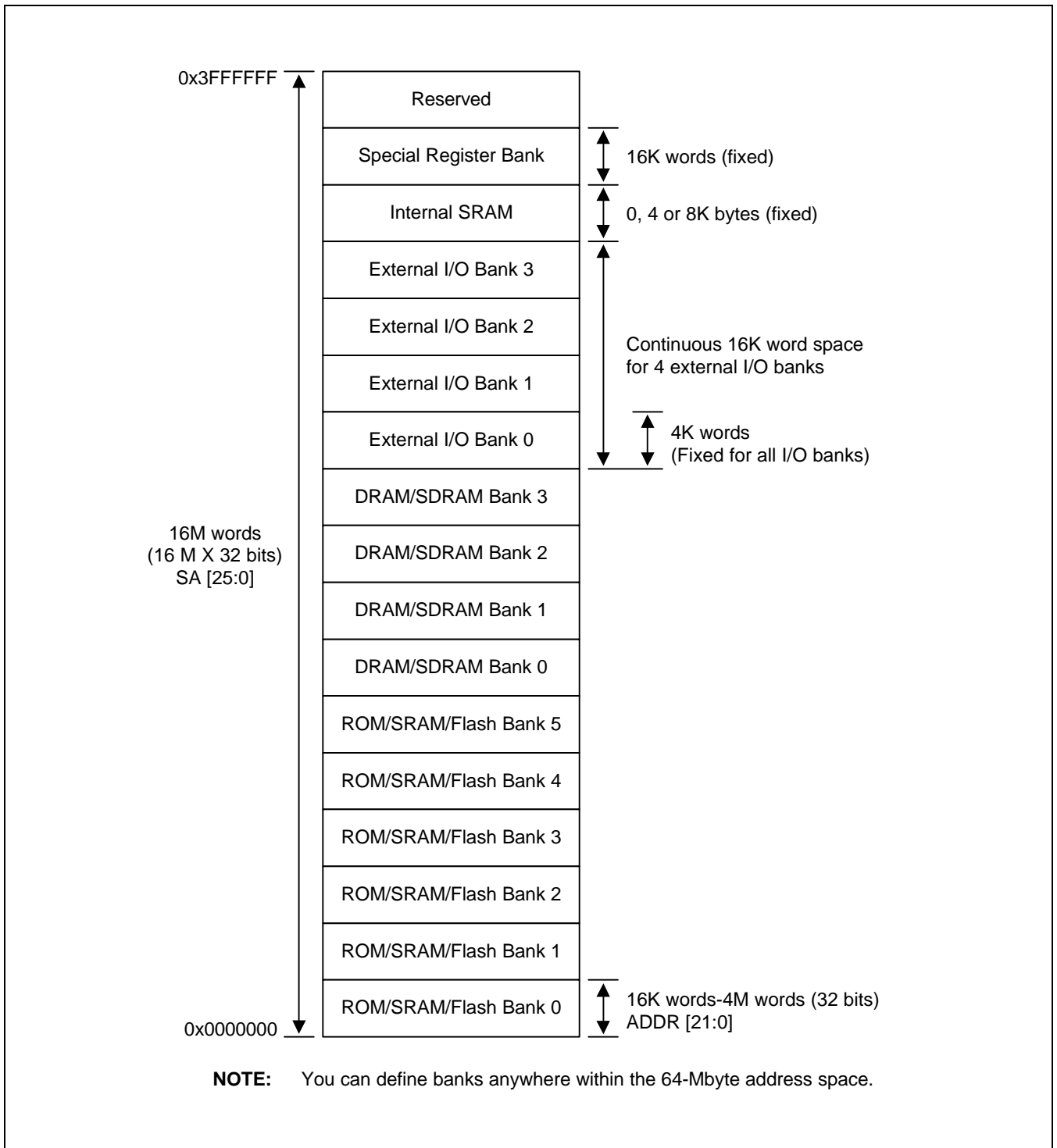

Figure 4-1. S3C4510B System Memory Map

## SYSTEM MEMORY MAP

Following are several important features to note about the S3C4510B system memory map:

- The size and location of each memory bank is determined by the register settings for "current bank base pointer" and "current bank end pointer". You can use this base/next bank pointer concept to set up a consecutive memory map. To do this, you set the base pointer of the "next bank" to the same address as the next pointer of the "current bank". Please note that when setting the bank control registers, the address boundaries of consecutive banks must not overlap. This can be applied even if one or more banks are disabled.
- Four external I/O banks are defined in a continuous address space. A programmer can only set the base pointer for external I/O bank 0. The start address of external I/O bank 1 is then calculated as the external I/O bank 0 start address + 16 K. Similarly, the start address for external I/O bank 2 is the external I/O bank 0 start address + 32 K, and the start address for external I/O bank 3 is the external I/O bank 0 start address + 48 K. Therefore, the total consecutive addressable space of the four external banks is defined as the start address of external I/O bank 0 + 64 K bytes.
- Within the addressable space, the start address of each I/O bank is not fixed. You can use bank control registers to assign a specific bank start address by setting the bank's base pointer. The address resolution is 64 K bytes. The bank's start address is defined as "base pointer << 16" and the bank's end address (except for external I/O banks) is "next pointer << 16 - 1".

After a power-on or system reset, all bank address pointer registers are initialized to their default values. In this case, all bank pointers except for the next pointer of ROM bank 0 are set to zero. This means that, except for ROM bank 0, all banks are undefined following a system start-up.

The reset values for the next pointer and base pointer of ROM bank 0 are 0x200 and 0x000, respectively. This means that a system reset automatically defines ROM bank 0 as a 32-Mbyte space with a start address of zero. This initial definition of ROM bank 0 lets the system power-on or reset operation pass control to the user-supplied boot code that is stored in external ROM. (This code is located at address 0 in the system memory map.) When the boot code (i.e. ROM program) executes, it performs various system initialization tasks and reconfigures the system memory map according to the application's actual external memory and device configuration.

The initial system memory map following system start-up is shown in Figure 4-2.

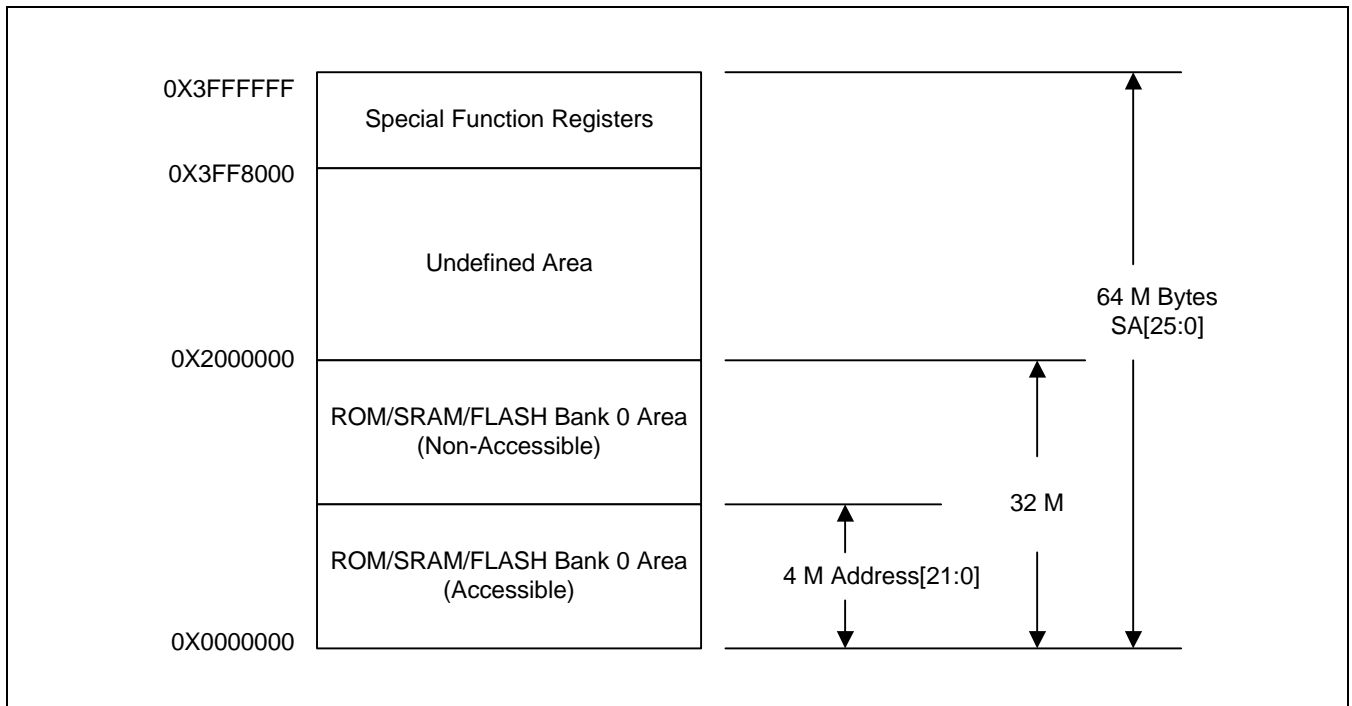

Figure 4-2. Initial System Memory Map (After Reset)

Table 4-1. System Manager Registers

Registers	Offset	R/W	Description	Reset Value
SYSCFG	0x0000	R/W	System configuration register	0x37FFFF91
CLKCON	0x3000	R/W	Clock control register	0x00000000
EXTACON0	0x3008	R/W	External I/O timing register 1	0x00000000
EXTACON1	0x300C	R/W	External I/O timing register 2	0x00000000
EXTDBWTH	0x3010	R/W	Data bus width of each bank	0x00000000
ROMCON0	0x3014	R/W	ROM/SRAM/Flash bank 0 control register	0x20000060
ROMCON1	0x3018	R/W	ROM/SRAM/Flash bank 1 control register	0x00000060
ROMCON2	0x301C	R/W	ROM/SRAM/Flash bank 2 control register	0x00000060
ROMCON3	0x3020	R/W	ROM/SRAM/Flash bank 3 control register	0x00000060
ROMCON4	0x3024	R/W	ROM/SRAM/Flash bank 4 control register	0x00000060
ROMCON5	0x3028	R/W	ROM/SRAM/Flash bank 5 control register	0x00000060
DRAMCON0	0x302C	R/W	DRAM bank 0 control register	0x00000000
DRAMCON1	0x3030	R/W	DRAM bank 1 control register	0x00000000
DRAMCON2	0x3034	R/W	DRAM bank 2 control register	0x00000000
DRAMCON3	0x3038	R/W	DRAM bank 3 control register	0x00000000
REFEXTCON	0x303C	R/W	Refresh and external I/O control register	0x000083FD

**EXTERNAL ADDRESS TRANSLATION METHOD DEPENDS ON THE WIDTH OF EXTERNAL MEMORY**

The S3C4510B address bus is, in some respects, different than the bus used in other standard CPUs. Based on the required data bus width of each memory bank, the internal system address bus is shifted out to an external address bus, ADDR[21:0]. This means that memory control signals such as nRAS[3:0], nCAS[3:0], nECS[3:0], nRCS[5:0], and nWBE[3:0] are generated by the system manager according to a pre-configured external memory scheme (see Table 4-2). This is applied to SDRAM signals as same method.

**Table 4-2. Address Bus Generation Guidelines**

Data Bus Width	External Address Pins, ADDR[21:0]	Accessible Memory Size
8-bit	A21–A0 (internal)	4M bytes
16-bit	A22–A1 (internal)	4M half-words
32-bit	A23–A2 (internal)	4M words

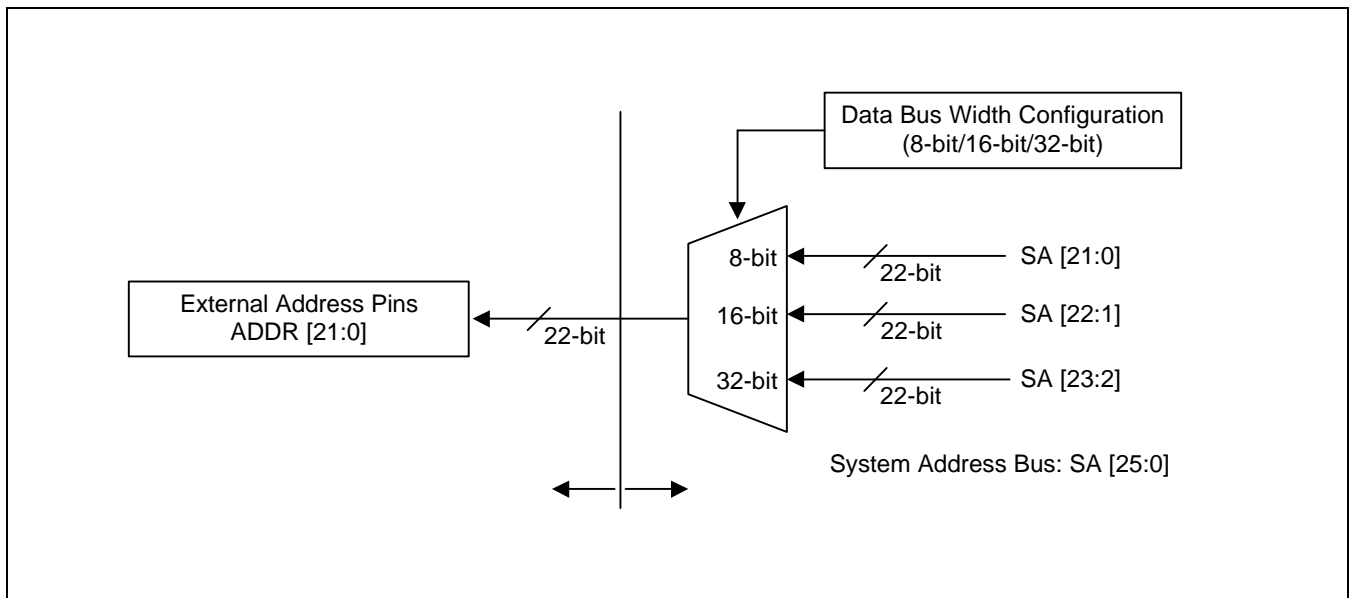

**Figure 4-3. External Address Bus Diagram**

## CONNECTION OF EXTERNAL MEMORY WITH VARIOUS DATA WIDTH

As another example, let us see how the S3C4510B maps CPU address spaces to physical addresses in external memory:

When the CPU issues an arbitrary address to access an external memory device, the S3C4510B compares the upper 10 bits of the issued address with the address pointers of all memory banks. It does this by consecutively subtracting each address pointer value from the CPU address. There are two reasons why this subtraction method is used:

- To check the polarities of the subtraction result so as to identify which bank corresponds to the address issued by the CPU.
- To derive the offset address for the corresponding bank.

When the bank is identified and the offset has been derived, the corresponding bank selection signal (nRCS[5:0], or nECS[3:0]) is generated, and the derived offset is driven to address external memory through the S3C4510B physical address bus.

The S3C4510B can be configured as big-endian or little-endian mode by external little/big selection pin(LITTLE, 49).

In Big Endian mode, the most significant byte of the external memory data is stored at the lowest numbered byte and the least significant byte at the highest numbered byte.

Eg.) In case of the external word memory system, Byte 0 of the memory is connected to data lines 31 through 24, D[31:24].

In Little Endian mode, vice versa.(See Figure 4-4 External Memory Interface)

**ENDIAN MODES**

S3C4510B supports both little-endian and big-endian for external memory or I/O devices by setting the pin LITTLE (pin 49). The system diagram for S3C4510B is shown in Figure 4-4.

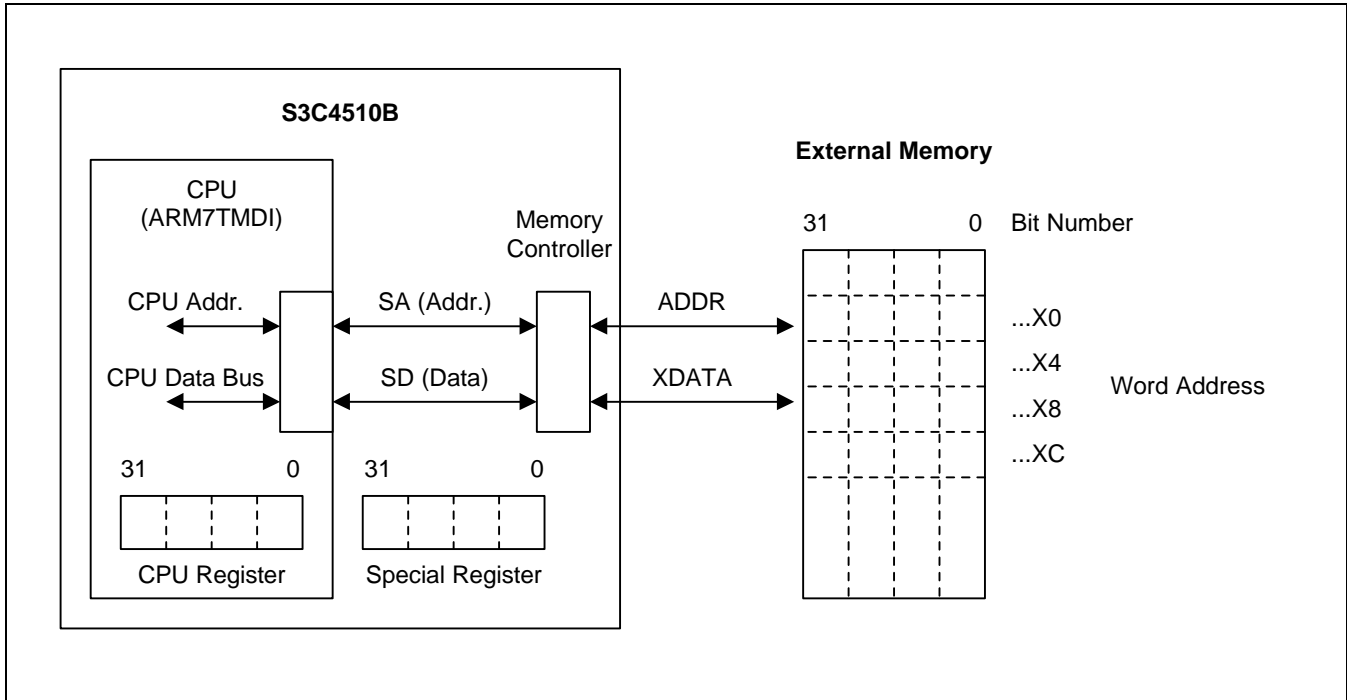

**Figure 4-4. Data Bus Connection with External Memory**

Below tables (4-4 through 4-14) are show the program/data path between the CPU register and the external memory using little-/big-endian and word/half-word/byte access.

**Table 4-3 and Table 4-4**

Using big-endian and word access, Program/Data path between register and external memory

WA=Address whose LSB is 0, 4, 8, C X=Don't care

CAS3-0/nWBE3-0=0 means active and 1 means inactive

Table 4-3. Word Access Store Operation with Big-Endian

Ext. Memory Type	STORE (CPU Reg → External Memory)						
	Word	Half Word		Byte			
Bit Num. CPU Register Data	31 0 abcd	31 0 abcd		31 0 abcd			
CPU Address	WA	WA		WA			
Bit Num. CPU Data Bus	31 0 abcd	31 0 abcd	31 0 abcd	31 0 abcd	31 0 abcd	31 0 abcd	31 0 abcd
Bit Num. Internal SD Bus	31 0 abcd	31 0 abcd	31 0 abcd	31 0 abcd	31 0 abcd	31 0 abcd	31 0 abcd
External Address	WA	WA	WA + 2	WA	WA + 1	WA + 2	WA + 3
CAS3-0/nWBE3-0	0000	XX00	XX00	XXX0	XXX0	XXX0	XXX0
Bit Num. XDATA	31 0 abcd	15 0 ab	15 0 cd	7 0 a	7 0 b	7 0 c	7 0 d
Bit Num. Ext. Memory Data	31 0 abcd	15 0 ab	15 0 cd	7 0 a	7 0 b	7 0 c	7 0 d
Timing Sequence		1st write	2nd write	1st write	2nd write	3rd write	4th write

**Table 4-4 Word Access Load Operation with Big-Endian**

Ext. Memory Type	LOAD (CPU Reg ← External Memory)						
	Word	Half Word		Byte			
Bit Num. CPU Register Data	31 0 abcd	31 0 abcd		31 0 abcd			
CPU Address	WA	WA		WA			
Bit Num. CPU Data Bus	31 0 abcd	31 0 abXX	31 0 abcd	31 0 aXXX	31 0 abXX	31 0 abcX	31 0 abcd
Bit Num. Internal SD Bus	31 0 abcd	31 0 abXX	31 0 abcd	31 0 aXXX	31 0 abXX	31 0 abcX	31 0 abcd
External Address	WA	WA	WA + 2	WA	WA + 1	WA + 2	WA + 3
CAS3-0/nWBE3-0	0000	XX00	XX00	XXX0	XXX0	XXX0	XXX0
Bit Num. XDATA	31 0 abcd	15 0 ab	15 0 cd	7 0 a	7 0 b	7 0 c	7 0 d
Bit Num. Ext. Memory Data	31 0 abcd	15 0 ab	15 0 cd	7 0 a	7 0 b	7 0 c	7 0 d
Timing Sequence		1st read	2nd read	1st read	2nd read	3rd read	4th read

**Table 4-5 and 4-6**

Using big-endian and half-word access, Program/Data path between register and external memory.

HA=Address whose LSB is 0, 2, 4, 6, 8, A, C, E

HAL=Address whose LSB is 0, 4, 8, C

HAU=Address whose LBS is 2, 6, A, E

X=Don't care

CAS3-0/nWBE3-0=0 means active and 1 means inactive

**Table 4-5. Half-Word Access Store Operation with Big-Endian**

Ext. Memory Type	STORE (CPU Reg → External Memory)				
	Word		Half word	Byte	
Bit Num. CPU Register Data	31 0 abcd		31 0 abcd	31 0 abcd	
CPU Address	HAL	HAU	HA	HA	
Bit Num. CPU Data Bus	31 0 cdcd	31 0 cdcd	31 0 cdcd	31 0 cdcd	31 0 cdcd
Bit Num. Internal SD Bus	31 0 cdcd	31 0 cdcd	31 0 cdcd	31 0 cdcd	31 0 cdcd
External Address	HAL	HAL	HA	HA	HA + 1
CAS3-0/nWBE3-0	0011	1100	XX00	XXX0	XXX0
Bit Num. XDATA	31 0 cdXX	31 0 XXcd	15 0 cd	7 0 c	7 0 d
Bit Num. Ext. Memory Data	31 16 cd	15 0 cd	15 0 cd	7 0 c	7 0 d
Timing Sequence				1st write	2nd write

**Table 4-6. Half-Word Access Load Operation with Big-Endian**

Ext. Memory Type	LOAD (CPU Reg ← External Memory)				
	Word		Half word	Byte	
Bit Num. CPU Register Data	15 0 ab		15 0 ab	15 0 ab	
CPU Address	HAL	HAU	HA	HA	
Bit Num. CPU Data Bus	31 0 abab	31 0 cdcd	31 0 abab	31 0 aXaX	31 0 abab
Bit Num. Internal SD Bus	31 0 abab	31 0 cdcd	31 0 abab	31 0 aXaX	31 0 abab
External Address	HAL	HAL	HA	HA	HA + 1
CAS3-0/nWBE3-0	XXXX	XXXX	XXXX	XXXX	XXXX
Bit Num. XDATA	31 0 abcd	31 0 abcd	15 0 ab	7 0 a	7 0 b
Bit Num. Ext. Memory Data	31 0 abcd		15 0 ab	7 0 a	7 0 b
Timing Sequence				1st read	2nd read



**Table 4-7 and 4-8**

Using big-endian and byte access, Program/Data path between register and external memory

BA=Address whose LSB is 0,1,2,3,4,5,6,7,8,9,A,B,C,D,E,F

BAL=Address whose LSB is 0,2,4,6,8,A,C,E

BAU=Address whose LBS is 1,3,5,7,9,B,D,F

BA0=Address whose LSB is 0,4,8,C

BA1=Address whose LBS is 1,5,9,D

BA2=Address whose LSB is 2,6,A,E

BA3=Address whose LBS is 3,7,B,F

X=Don't care

CAS3-0/nWBE3-0=0 means active and 1 means inactive

**Table 4-7. Byte Access Store Operation with Big-Endian**

Ext. Memory Type	STORE (CPU Reg → External Memory)						
	Word				Half Word		Byte
Bit Num. CPU Register Data	31 0 abcd				31 0 abcd		31 0 abcd
CPU Address	BA0	BA1	BA2	BA3	BAL	BAU	BA
Bit Num. CPU Data Bus	31 0 dddd	31 0 dddd	31 0 dddd	31 0 dddd	31 0 dddd	31 0 dddd	31 0 dddd
Bit Num. Internal SD Bus	31 0 dddd	31 0 dddd	31 0 dddd	31 0 dddd	31 0 dddd	31 0 dddd	31 0 dddd
External Address	BA0	BA0	BA0	BA0	BAL	BAL	BA
CAS3-0/nWBE3-0	0111	1011	1101	1110	XX10	XX01	XXX0
Bit Num. XDATA	31 0 dXXX	31 0 XdXX	31 0 XXdX	31 0 XXXd	15 0 dX	15 0 Xd	7 0 d
Bit Num. Ext. Memory Data	31 24 d	23 16 d	15 8 d	7 0 d	15 0 d	15 0 d	7 0 d
Timing Sequence							

Table 4-8. Byte Access Load Operation with Big-Endian

Ext. Memory Type	LOAD (CPU Reg ← External Memory)						
	Word				Half Word		Byte
Bit Num. CPU Register Data	7 0 a				7 0 a		7 0 a
CPU Address	BA0	BA1	BA2	BA3	BAL	BAU	BA
Bit Num. CPU Data Bus	31 0 aaaa	31 0 bbbb	31 0 cccc	31 0 dddd	31 0 aaaa	31 0 bbbb	31 0 aaaa
Bit Num. Internal SD Bus	31 0 aaaa	31 0 bbbb	31 0 cccc	31 0 dddd	31 0 aaaa	31 0 bbbb	31 0 aaaa
External Address	BA0	BA0	BA0	BA0	BAL	BAL	BA
CAS3-0/nWBE3-0	XXXX	XXXX	XXXX	XXXX	XXXX	XXXX	XXXX
Bit Num. XDATA	31 0 abcd	31 0 abcd	31 0 abcd	31 0 abcd	15 0 ab	15 0 ab	7 0 a
Bit Num. Ext. Memory Data	31 0 abcd				15 0 ab		7 0 a
Timing Sequence							

**Table 4-9 and 4-10**

Using little-endian and word access, Program/Data path between register and external memory

WA=Address whose LSB is 0,4,8,C

X=Don't care

CAS3-0/nWBE3-0=0 means active and 1 means inactive

**Table 4-9. Word Access Store Operation with Little-Endian**

Ext. Memory Type	STORE (CPU Reg → External Memory)						
	Word	Half Word		Byte			
Bit Num. CPU Register Data	31 0 abcd	31 0 abcd		31 0 abcd			
CPU Address	WA	WA		WA			
Bit Num. CPU Data Bus	31 0 abcd	31 0 abcd	31 0 abcd	31 0 abcd	31 0 abcd	31 0 abcd	31 0 abcd
Bit Num. Internal SD Bus	31 0 abcd	31 0 abcd	31 0 abcd	31 0 abcd	31 0 abcd	31 0 abcd	31 0 abcd
External Address		WA	WA	WA + 2	WA	WA + 1	WA + 2
Bit Num. XDATA	31 0 abcd	15 0 cd	15 0 ab	7 0 d	7 0 c	7 0 b	7 0 a
Bit Num. Ext. Memory Data	31 0 abcd	15 0 cd	15 0 ab	7 0 d	7 0 c	7 0 b	7 0 a
Timing Sequence		1st write	2nd write	1st write	2nd write	3rd write	4th write

**Table 4-10. Word Access Load Operation with Little-Endian**

Ext. Memory Type	LOAD (CPU Reg ← External Memory)						
	Word	Half Word		Byte			
Bit Num. CPU Register Data	31 0 abcd	31 0 abcd		31 0 abcd			
CPU Address	WA	WA		WA			
Bit Num. CPU Data Bus	31 0 abcd	31 0 XXcd	31 0 abcd	31 0 XXXd	31 0 XXcd	31 0 Xbcd	31 0 abcd
Bit Num. Internal SD Bus	31 0 abcd	31 0 XXcd	31 0 abcd	31 0 XXXd	31 0 XXcd	31 0 Xbcd	31 0 abcd
External Address	WA	WA	WA + 2	WA	WA + 1	WA + 2	WA + 3
Bit Num. XDATA	31 0 abcd	15 0 cd	15 0 ab	7 0 d	7 0 c	7 0 b	7 0 a
Bit Num. Ext. Memory Data	31 0 abcd	15 0 cd	15 0 ab	7 0 d	7 0 c	7 0 b	7 0 a
Timing Sequence		1st read	2nd read	1st read	2nd read	3rd read	4th read

**Table 4-11 and 4-12**

Using little-endian and half-word access, Program/Data path between register and external memory

HA=Address whose LSB is 0, 2, 4, 6, 8, A, C, E

HAL=Address whose LSB is 0, 4, 8, C

HAU=Address whose LBS is 2, 6, A, E

X=Don't care

CAS3-0/nWBE3-0=0 means active and 1 means inactive

**Table 4-11. Half-Word Access Store Operation with Little-Endian**

Ext. Memory Type	STORE (CPU Reg → External Memory)				
	Word		Half word	Byte	
Bit Num. CPU Register Data	31 0 abcd		31 0 abcd	31 0 d0 abc	
CPU Address	HAL	HAU	HA	HA	
Bit Num. CPU Data Bus	31 0 cdcd	31 0 cdcd	31 0 cdcd	31 0 cdcd	31 0 cdcd
Bit Num. Internal SD Bus	31 0 cdcd	31 0 cdcd	31 0 cdcd	31 0 cdcd	31 0 cdcd
External Address	HAL	HAL	HA	HA	HA+1
CAS3-0/nWBE3-0	1100	0011	XX00	XXX0	XXX0
Bit Num. XDATA	31 0 cdcd	31 0 cdcd	15 0 cd	7 0 d	7 0 c
Bit Num. Ext. Memory Data	15 0 cd	31 16 cd	15 0 cd	7 0 d	7 0 c
Timing Sequence				1st write	2nd write

**Table 4-12. Half-Word Access Load Operation with Little-Endian**

Ext. Memory Type	LOAD (CPU Reg ← External Memory)				
	Word		Half word	Byte	
Bit Num. CPU Register Data	15 0 cd		15 0 ab	15 0 ba	
CPU Address	HAL	HAU	HA	HA	
Bit Num. CPU Data Bus	31 0 cdcd	31 0 abab	31 0 abab	31 0 XaXa	31 0 baba
Bit Num. Internal SD Bus	31 0 cdcd	31 0 abab	31 0 abab	31 0 XaXa	31 0 baba
External Address	HAL	HAL	HA	HA	HA+1
CAS3-0/nWBE3-0	XXXX	XXXX	XXXX	XXXX	XXXX
Bit Num. XDATA	31 0 abcd	31 0 abcd	15 0 ab	7 0 a	7 0 b
Bit Num. Ext. Memory Data	31 0 abcd		15 0 ab	7 0 a	7 0 b
Timing Sequence				1st read	2nd read

**Table 4-13 and 4-14**

Using little-endian and byte access, Program/Data path between register and external memory

BA=Address whose LSB is 0,1,2,3,4,5,6,7,8,9,A,B,C,D,E,F

BAL=Address whose LSB is 0,2,4,6,8,A,C,E

BAU=Address whose LBS is 1,3,5,7,9,B,D,F

BA0=Address whose LSB is 0,4,8,C

BA1=Address whose LBS is 1,5,9,D

BA2=Address whose LSB is 2,6,A,E

BA3=Address whose LBS is 3,7,B,F

X=Don't care

CAS3-0/nWBE3-0=0 means active and 1 means inactive

**Table 4-13. Byte Access Store Operation with Little-Endian**

Ext. Memory Type	STORE (CPU Reg → External Memory)						
	Word				Half Word		Byte
Bit Num. CPU Register Data	31 0 abcd				31 0 abcd		31 0 abcd
CPU Address	BA0	BA1	BA2	BA3	BAL	BAU	BA
Bit Num. CPU Data Bus	31 0 dddd	31 0 dddd	31 0 dddd	31 0 dddd	31 0 dddd	31 0 dddd	31 0 dddd
Bit Num. Internal SD Bus	31 0 dddd	31 0 dddd	31 0 dddd	31 0 dddd	31 0 dddd	31 0 dddd	31 0 dddd
External Address	BA0	BA0	BA0	BA0	BAL	BAL	BA
CAS3-0/nWBE3-0	1110	1101	1011	0111	XX10	XX01	XXX0
Bit Num. XDATA	31 0 XXXd	31 0 XXdX	31 0 XdXX	31 0 dXXX	15 0 Xd	15 0 dX	7 0 d
Bit Num. Ext. Memory Data	7 0 d	15 8 d	23 16 d	31 24 d	7 0 d	15 8 d	7 0 d
Timing Sequence							

Table 4-14. Byte Access Load Operation with Little-Endian

Ext. Memory Type	LOAD (CPU Reg ← External Memory)						
	Word						
Bit Num. CPU Register Data	7 0 d	7 0 c	7 0 a				
CPU Address	BA0	BA1		BA3			
Bit Num. CPU Data Bus	31 0 dddd	31 0 cccc	31 0 bbbb	31 0 aaaa	31 0 bbbb	31 0 aaaa	31 0 aaaa
Bit Num. Internal SD Bus	31 0 dddd	31 0 cccc	31 0 bbbb	31 0 aaaa	31 0 bbbb	31 0 aaaa	31 0 aaaa
External Address	BA0	BA0	BA0	BA0	BAL	BAL	BA
CAS3-0/nWBE3-0	XXXX	XXXX	XXXX	XXXX	XXXX	XXXX	XXXX
Bit Num. XDATA	31 0 abcd	31 0 abcd	31 0 abcd	31 0 abcd	15 0 ab	15 0 ab	7 0 a
Bit Num. Ext. Memory Data	31 0 abcd				15 0 ab		7 0 a
Timing Sequence							

## BUS ARBITRATION

In the S3C4510B microcontroller, the term "system bus" refers to the separate system address and data buses inside the chip. The S3C4510B's internal function blocks, or external devices, can request mastership of the system bus and then hold the system bus in order to perform data transfers. Because the design of S3C4510B bus allows only one bus master at a time, a bus controller is required to arbitrate when two or more internal units or external devices simultaneously request bus mastership.

When bus mastership is granted to an internal function block or an external device, other pending requests are not acknowledged until the previous bus master has released the bus.

To facilitate bus arbitration, priorities are assigned to each internal S3C4510B function block. The bus controller arbitrates requests for the bus mastership according to these fixed priorities. In the event of contention, mastership is granted to the function block with the highest assigned priority. These priorities are listed in Table 4-15.

### NOTE

An external bus master can also be granted bus mastership and hold the S3C4510B system bus. In Table 4-3, you will note that all external devices are assigned the identical priority. Therefore, in systems made up of several external devices which can become the bus master, external circuitry must be implemented to assign additional bus arbitration priorities to all potential external bus masters.

**Table 4-15. Bus Priorities for Arbitration**

Function Block	Bus Priority (Group)
External bus master	A-1 (Highest priority in Group A)
DRAM memory refresh controller	A-2
General DMA 1 (GDMA 1)	A-3
General DMA 0 (GDMA 0)	A-4
High level data link controller B (HDLC B)	A-5
High level data link controller A (HDLC A)	A-6
MAC buffered DMA (BDMA)	A-7 (Lowest priority in Group A)
Writer buffer	B-1 (Highest priority in Group B)
Bus router	B-2 (Lowest priority in Group B)

**NOTE:** Internal function blocks are divided into two groups, Group A and Group B. Within each group, the bus arbitration priorities are fixed according to the assigned level. The relative priority of Group A and Group B is determined more or less in an alternating manner.

## EXTERNAL BUS MASTERSHIP

The S3C4510B can receive and acknowledge bus request signals (ExtMREQs) that are generated by an external bus master. When the CPU asserts an external bus acknowledge signal (ExtMACK), mastership is granted to the external bus master, assuming the external bus request is still active.

When the external bus acknowledge signal is active, the S3C4510B's memory interface signals go to high-impedance state so that the external bus master can drive the required external memory interface signals.

The S3C4510B does not perform DRAM refreshes when it is not the bus master. When an external bus master is in control of the external bus, and if it retains control for a long period of time, it must assume the responsibility of performing the necessary DRAM refresh operations.

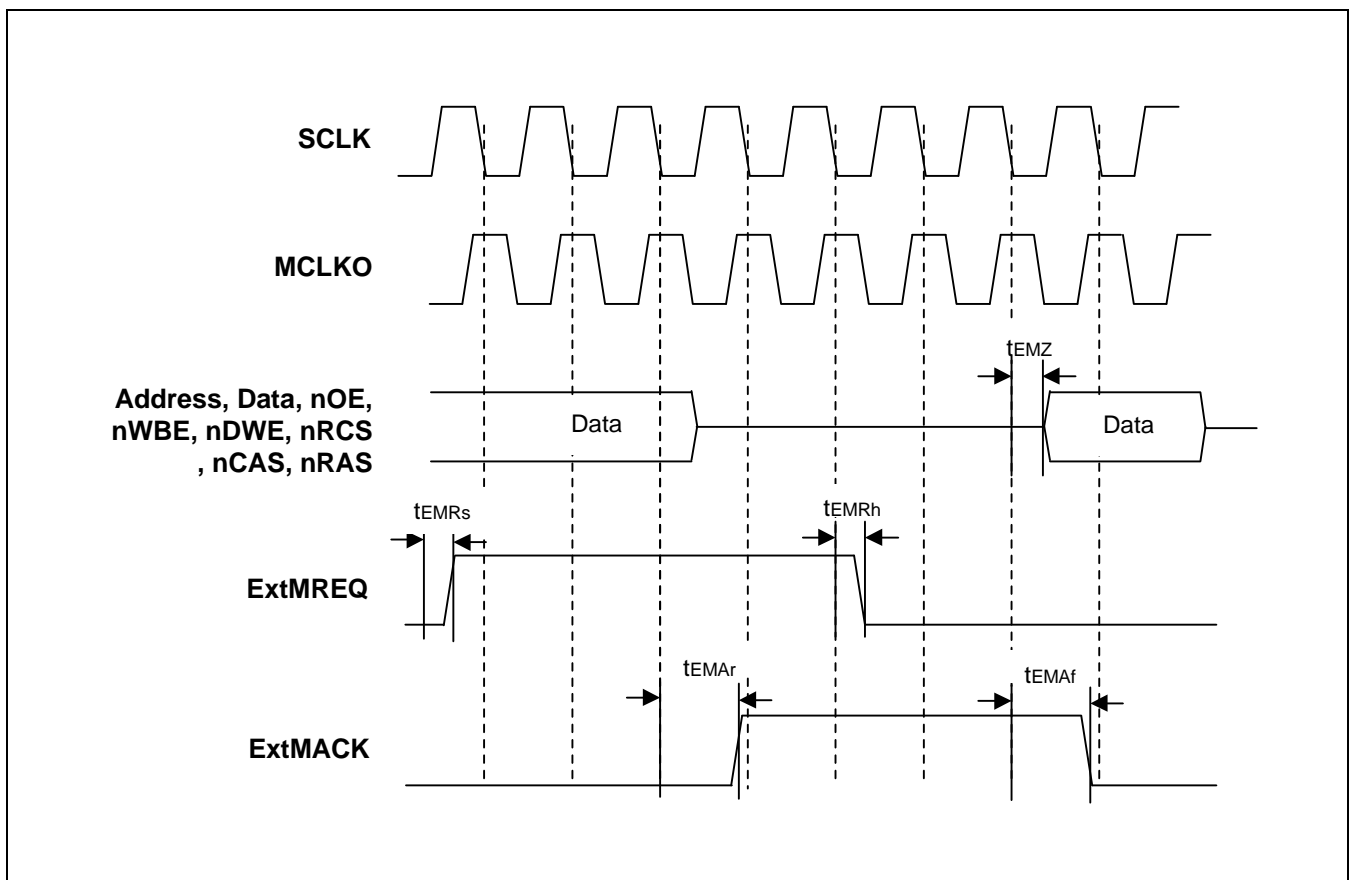

**Figure 4-5. External Bus Request Timing**

**NOTE:** When External Bus Master requests the ExtMREQ during the Sync DRAM writing cycles, the ExtMACK can be generated with the wrong writing control signals of Sync DRAM. Just floating the Sync DRAM control signals at the time ExtMACK, it can cause the feasible active writing on the Sync DRAM. As the result, the wrong data can be written into unexpected address on Sync DRAM. If this address is in the range of stack or code area, the crash will be happen sooner or later. The other memory interfaces doesn't have this problem, which is asynchronous with MCLKO, that is why Sync DRAM write cycle only. You can avoid this by disabling the SDCS (Sync DRAM Chip Select HIGH) as soon as receiving the ExtMACK and driving the Address and Data after one or two MCLKO cycles.



## CONTROL REGISTERS

### SYSTEM CONFIGURATION REGISTER (SYSCFG)

The System Manager has one system configuration register, SYSCFG. The SYSCFG register determines the start address of the System Manager's special registers and the start address of internal SRAM. (The total special register space in the system memory map is fixed at 64 K bytes.)

You also use SYSCFG settings to control write buffer enable, cache enable, and stall enable operations.

All DRAM banks can be configured to SDRAM banks by set the Synchronous DRAM mode (SYSCFG[31]).

#### NOTE

If you write a "10" into the cache mode field, SYSCFG[5:4], the cache enable bit is cleared automatically (see Figure 4-6).

**Table 4-16. SYSCFG Register**

Registers	Offset Address	R/W	Description	Reset Value
SYSCFG	0x0000	R/W	System configuration register	0x37FFFF91

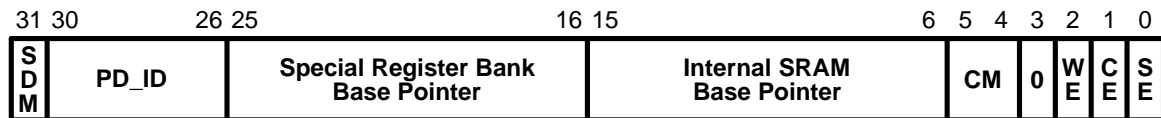
**[0] Stall enable (SE)**

Must be set to zero.

**[1] Cache enable (CE)**

When set to '1', cache operations are enabled.

**[2] Write buffer enable (WE)**

When set to "1", write buffer operations are enabled.

**[5:4] Cache mode (CM)**

This 2-bit value determines how internal memory is to be divided into cache and SRAM.

00 = 4-Kbyte SRAM, 4Kbyte cache

01 = 0-Kbyte SRAM, 8Kbyte cache

10 = 8-Kbyte SRAM, 0Kbyte cache

**NOTE:** When you write 10 to this field, the cache enable bit is cleared automatically.

**[15:6] Internal SRAM base pointer**

This 10-bit address becomes the upper address of SRAM. A25 through A16, the remaining SRAM address, and A15 through A0, are filled with zeros.

**[25:16] Special register bank base pointer**

The resolution of this value is 64K. Therefore, to place the start address at 1800000H (24M), use this formula:  
Setting value = (1800000H/64K) << 16.

**[30:26] Product Identifier (PD\_ID)**

00001 = S3C4510X (KS32C50100)

11001 = S3C4510B

**[31] Sync. DRAM Mode**

0 = Normal/EDO DRAM interface for 4 DRAM banks

1 = Sync. DRAM interface for 4 DRAM banks.

**Figure 4-6. System Configuration Register (SYSCFG)**

### Start Address Setting

The start address of the System Manager special register area is initialized to 3FFFF91H. (You can also set the start address to an arbitrary value by writing the address, 3FF0000H.) When you have set the start address of the special register area, the register addresses are automatically defined as the start address plus the register's offset.

Assume for example, that a reset initialize the start address to 3FF0000H. The offset address of the ROMCON register is 3014H. Therefore, the physical address for ROMCON is  $3FF0000H + 3014h = 3FF3014H$ . If you then modified the start address of the special register area to 3000000H, the new address for the ROMCON register would be 3003014H.

### Cache Disable/Enable

To enable or disable the cache, you set the cache enable (CE) bit of the SYSCFG register to "1" or "0", respectively. Because cache memory does not have an auto-flush feature, you must be careful to verify the coherency of data whenever you re-enable the cache. You must also carefully check any changes that the DMA controller may make to data stored in memory.

(Usually, the memory area that is allocated to DMA access operations must be non-cachable.)

The internal 8-Kbyte SRAM can be used as a cache area. To configure this area, you use the cache mode bits, SYSCFG[5:4]. If you do not need to use the entire 8-Kbyte area as cache, you can use the remaining area as internal SRAM. This area is accessed using the address of the base pointer in the internal SRAM field.

### Write Buffer Disable/Enable

The S3C4510B has four programmable write buffer registers that are used to improve the speed of memory write operations. When you enable a write buffer, the CPU writes data into the write buffer, instead of an external memory location. This saves the cycle that would normally be required to complete the external memory write operation. The four write buffers also enhance the performance of the ARM7TDMI core's store operations.

To maintain data coherency between the cache and external memory, the S3C4510B uses a write-through policy. An internal 4-level write buffer compensates for performance degradation caused by write-throughs.

(For more information, read Chapter 5.)

## SYSTEM CLOCK AND MUX BUS CONTROL REGISTER

### CLOCK CONTROL REGISTER (CLKCON)

There is a clock control register in the System Manager. This control register is used to divide the internal system clock, so the slower clock than the system clock can be made by clock dividing value. In this register, ROM bank 5 address/data MUX. enable control function is included.

**Table 4-17. CLKCON Register**

Registers	Offset Address	R/W	Description	Reset Value
CLKCON	0x3000	R/W	Clock control register	0x00000000

**Table 4-18. CLKCON Register Description**

Bit Number	Bit Name	Description
[15:0]	Clock dividing value	S3C4510B System Clock source. If CLKSEL is Low, PLL output clock is used as the S3C4510B internal system clock. If CLKSEL is High, XCLK is used as the S3C4510B internal system clock. The internal system clock is divided by this value. The clock divided is used to drive the CPU and system peripherals. Only one bit can be set in CLKCON[15:0], that is, the clock dividing value is defined as 1, 2, 4, 8, 16,... If all bits are zero, a non-divided clock is used.
[16]	ROM bank 5 wait enable	Wait cycle will check the next cycle after a chip selection signal is activated.
[17]	ROM bank 5 address/data MUX. enable	Using multiplex bus at ROM bank 5, this bit must be set to 1.
[19:18]	MUX Bus address cycle	When address phase of multiplexed bus is not enough long for external device to receive, address phase can be extended by setting this bit. (You can see tAC in timing diagram.) 00 = 1 MCLK 01 = 2 MCLK 10 = 3 MCLK
[31]	Test bit	This bit is for factory use only. During the normal operation, it must always be 0.

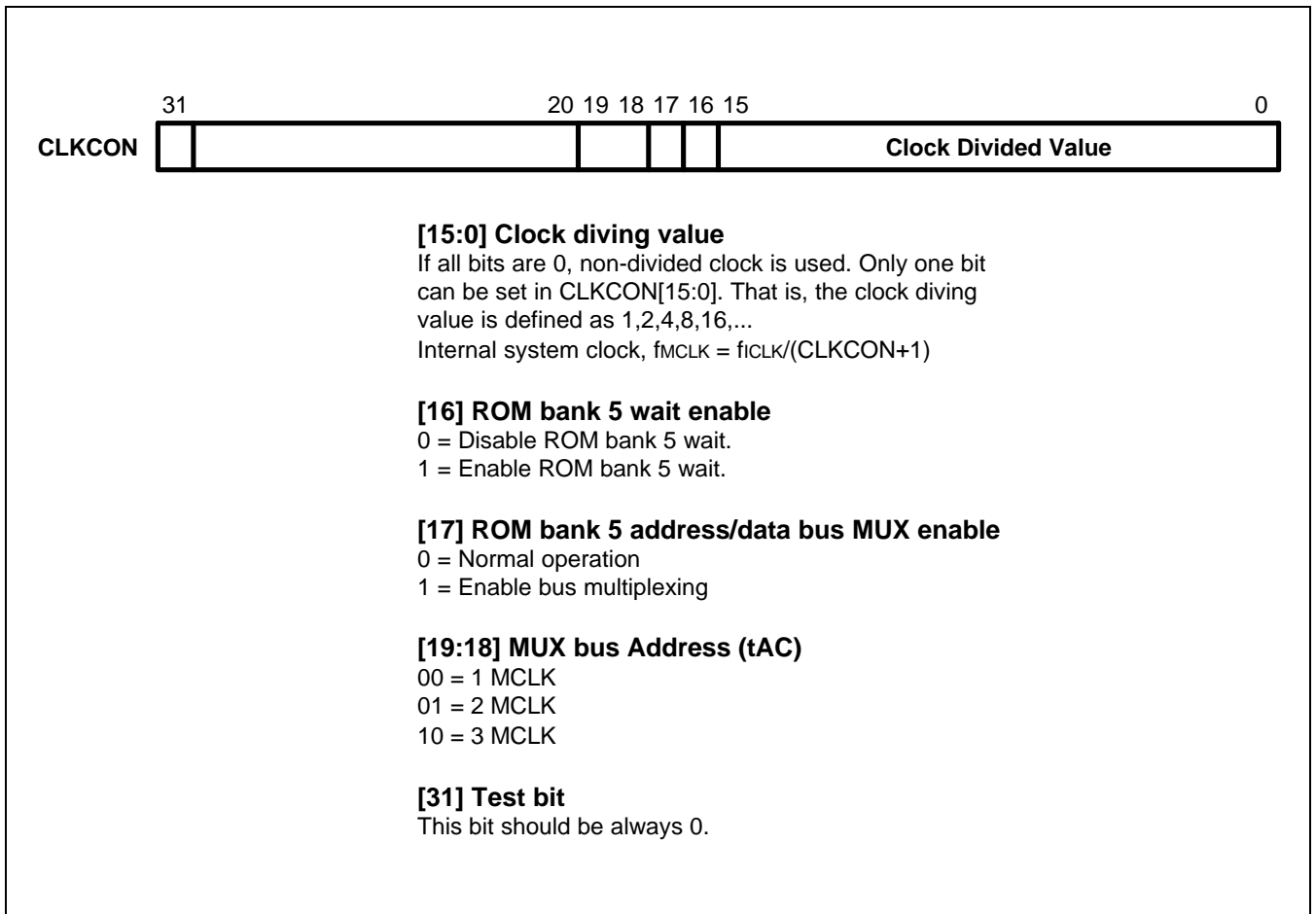
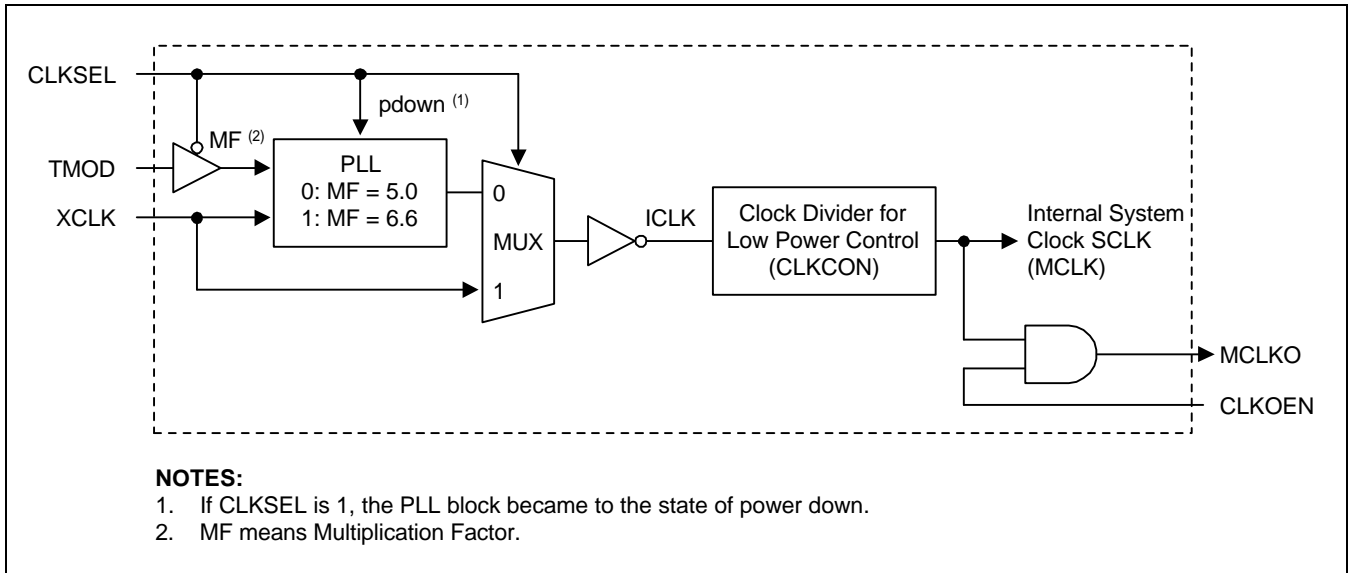

Figure 4-7. Clock Control Register (CLKCON)

**SYSTEM CLOCK**

The external clock input, XCLK, can be used to the internal system clock by assign  $V_{DD}$  to CLKSEL pin. Using PLL for the internal system clock,  $V_{SS}$  has to be assigned to CLKSEL pin. In this case, the internal system clock is  $XCLK \times MF$ . To get 50MHz of system clock, a 10 MHz external clock must be used.

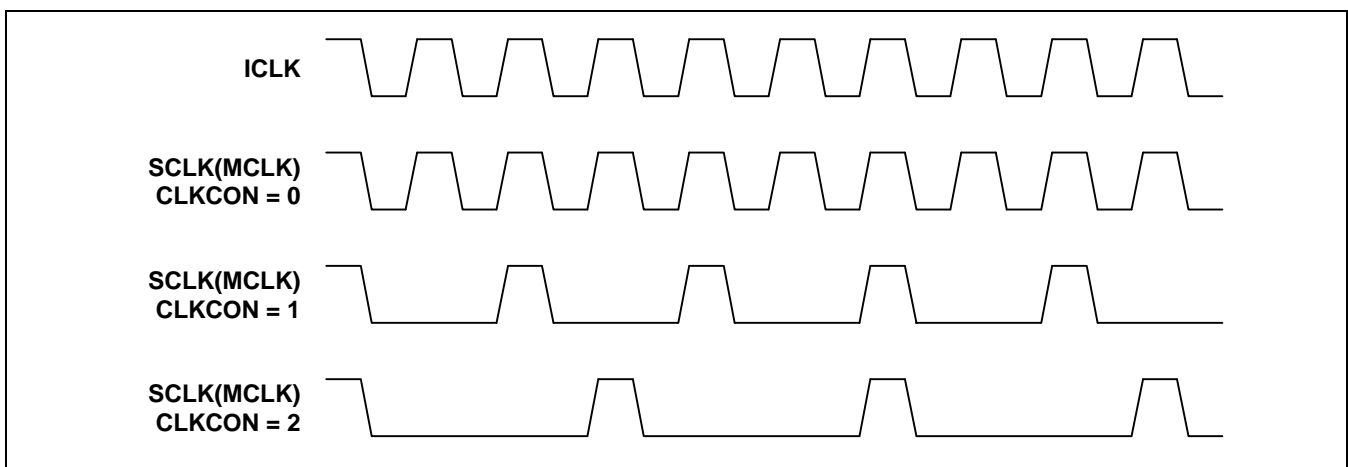

**Figure 4-8. System Clock Circuit**

For the purpose of power save, Clock Control Register (CLKCON) can be programed at low frequency. When the internal system clock is divided by CLKCON, it's duty-cycle is changed.

If CLKCON is programed to zero, the internal system clock remains the same as the internal clock, ICLK. In other cases, the duty cycle of internal system clock is no longer 50%.

Figure 4-9 shows the internal system clock, SCLK(MCLK) waveform according to the clock dividing value.



**Figure 4-9. Divided System Clocks Timing Diagram**

## EXTERNAL I/O ACCESS CONTROL REGISTERS (EXTACON0/1)

The System Manager has four external I/O access control registers. These registers correspond to the up to four external I/O banks that are supported by S3C4510B. Table 4-19 describes the two registers that are used to control the timing of external I/O bank accesses.

You can control external I/O access cycles using either a specified value or an external wait signal, nEWAIT. To obtain access cycles that are longer than those possible with a specified value, you can delay the active time of nOE or nWBE by tCOS value setting. After nOE or nWBE active, nEWAIT should be active previously at the first MCLK(SCLK) falling edge. In case of ROM bank 5, nRCS and nOE/nWBE signals are activated simultaneously, that is, there is no control parameter as like tCOS. As a result, nEWAIT should be valid previously at the second MCLK(SCLK) falling edge after nRCS active for the ROM bank 5.

EXTACON0 is used to set the access timings for external I/O banks 0 and 1. EXTACON1 is used to set the external access timings for I/O banks 2 and 3.

### NOTE

The base pointer for external I/O bank 0 is set in the REFEXTCON register(REFEXTCON register is in DRAM control registers part).

**Table 4-19. External I/O Access Control Register Description**

Registers	Offset Address	R/W	Description	Reset Value
EXTACON0	0x3008	R/W	External I/O access timing register 0	0x00000000
EXTACON1	0x300C	R/W	External I/O access timing register 1	0x00000000

	31	30	29	28	27	25	24	22	21	19	18	16	15	14	13	12	11	9	8	6	5	3	2	0	
EXTACON0	0	0	0	0	tACC1	tCOH1	tACS1	tcOS1	0	0	0	0	tACC0	tCOH0	tACS0	tcOS0									
EXTACON1	0	0	0	0	tACC3	tCOH3	tACS3	tcOS3	0	0	0	0	tACC2	tCOH2	tACS2	tcOS2									

**[2:0] Chip selection set-up time on nOE (tcOS0, tcOS2)**

**[18:16] tcOS1, tcOS3**  
 000 = 0 cycle      100 = 4 cycles  
 001 = 1 cycle      101 = 5 cycles  
 010 = 2 cycles     110 = 6 cycles  
 011 = 3 cycles     111 = 7 cycles

**[5:3] Address set-up time before nECS (tACS0, tACS2)**

**[21:19] tACS1, tACS3**  
 000 = 0 cycle      100 = 4 cycles  
 001 = 1 cycle      101 = 5 cycle  
 010 = 2 cycles     110 = 6 cycle  
 011 = 3 cycles     111 = 7 cycles

**[8:6] Chip selection hold time on nOE (tCOH0, tCOH2)**

**[24:22] tCOH1, tCOH3**  
 000 = 0 cycle      100 = 4 cycles  
 001 = 1 cycle      101 = 5 cycles  
 010 = 2 cycles     110 = 6 cycles  
 011 = 3 cycles     111 = 7 cycles

**[11:9] Access cycles (nOE low time) (tACC0, tACC2)**

**[27:25] tACC1, tACC3**  
 000 = 0 cycle      100 = 4 cycles  
 001 = 1 cycle      101 = 5 cycles  
 010 = 2 cycles     110 = 6 cycles  
 011 = 3 cycles     111 = 7 cycles

Figure 4-10. External I/O Access Control Registers (EXTACON0, EXTACON1)



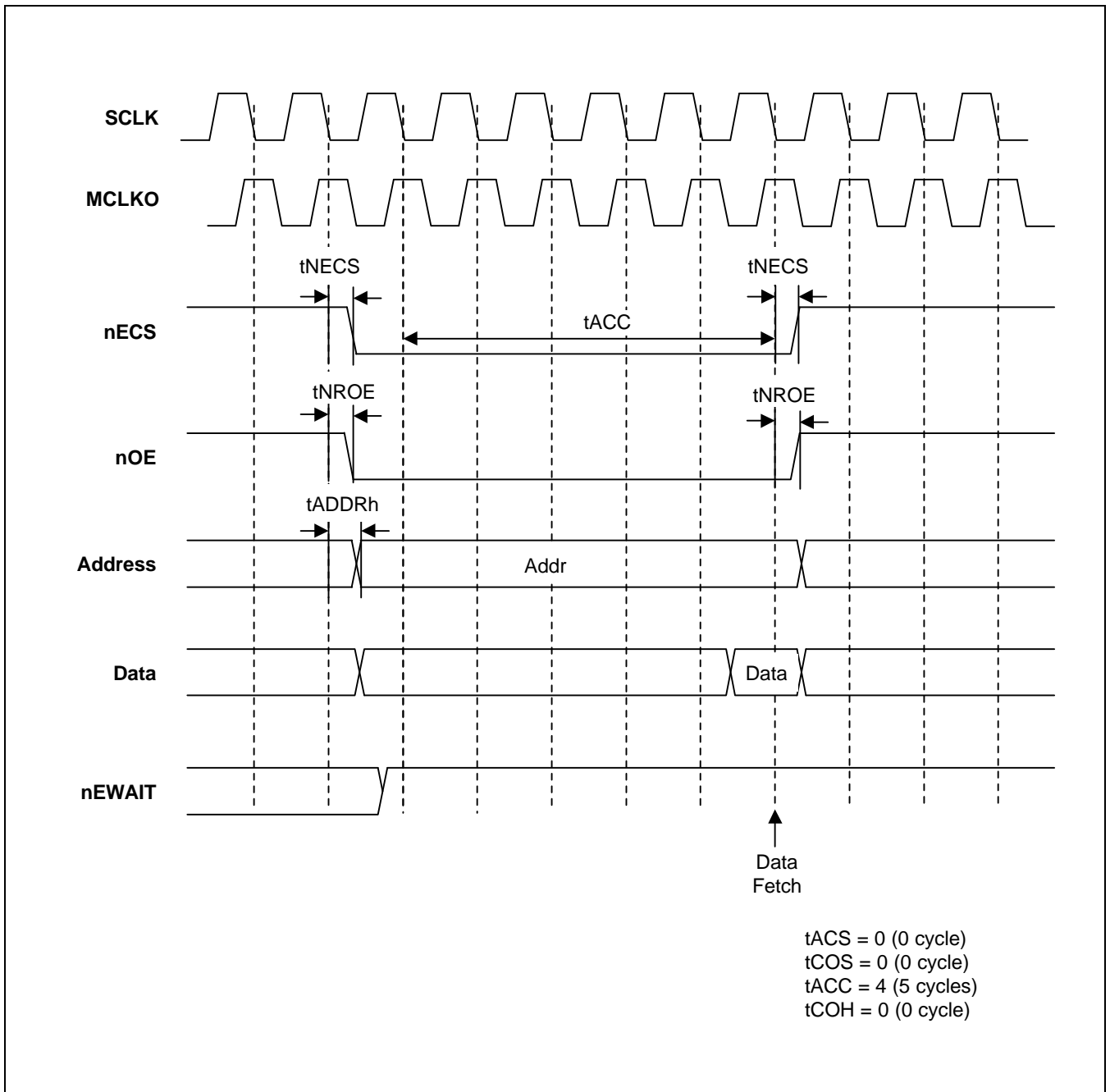

Figure 4-11. External I/O Read Timing 1

When nEWAIT is asserted for external I/O banks, the tCOS and tCOH should not be zero. When ROM banks, except ROM bank 5, are selected, the nEWAIT can not be asserted.

Even if you does not use nEWAIT, nEWAIT pin should be connected pull-up for safe operation.

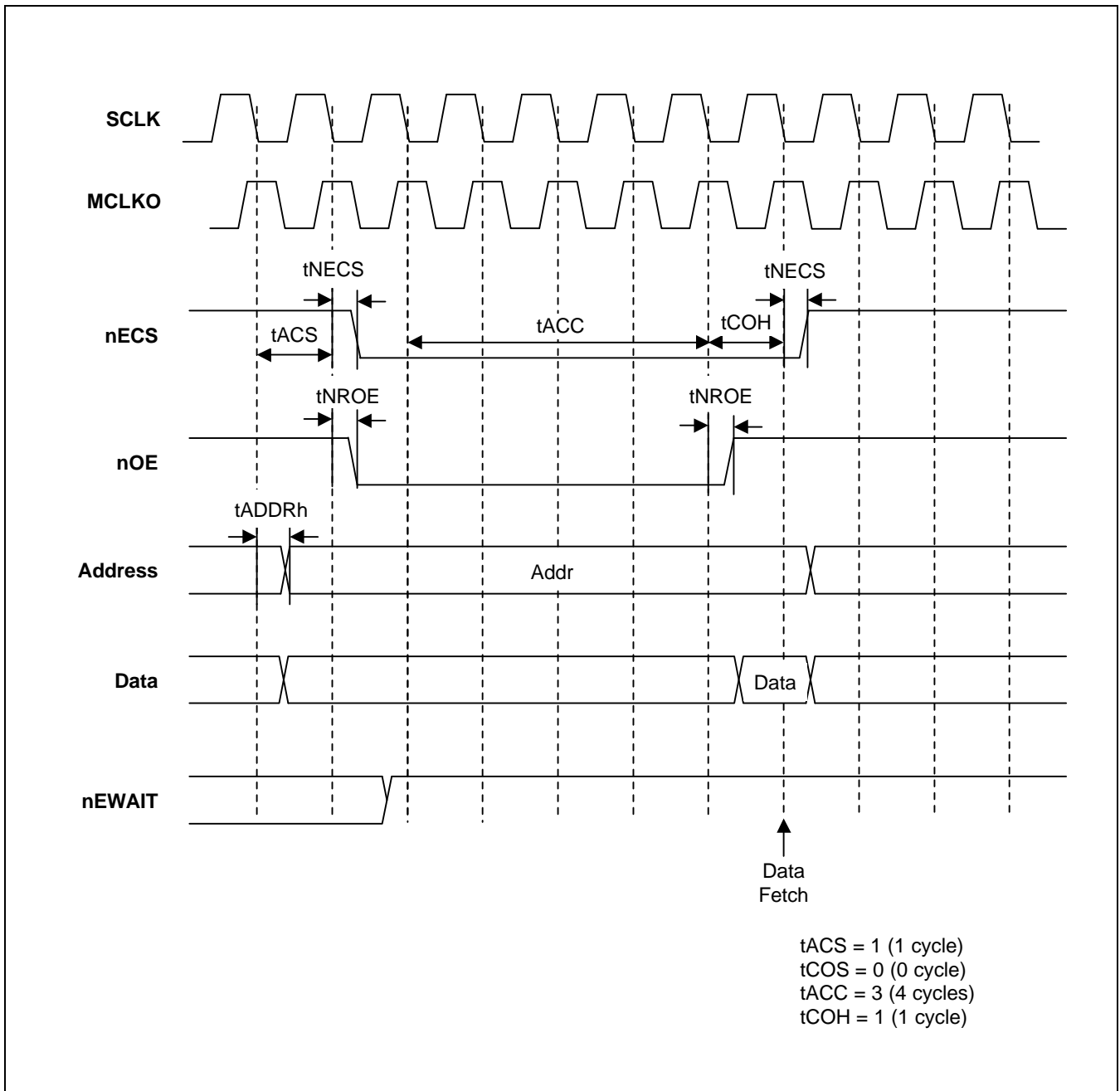
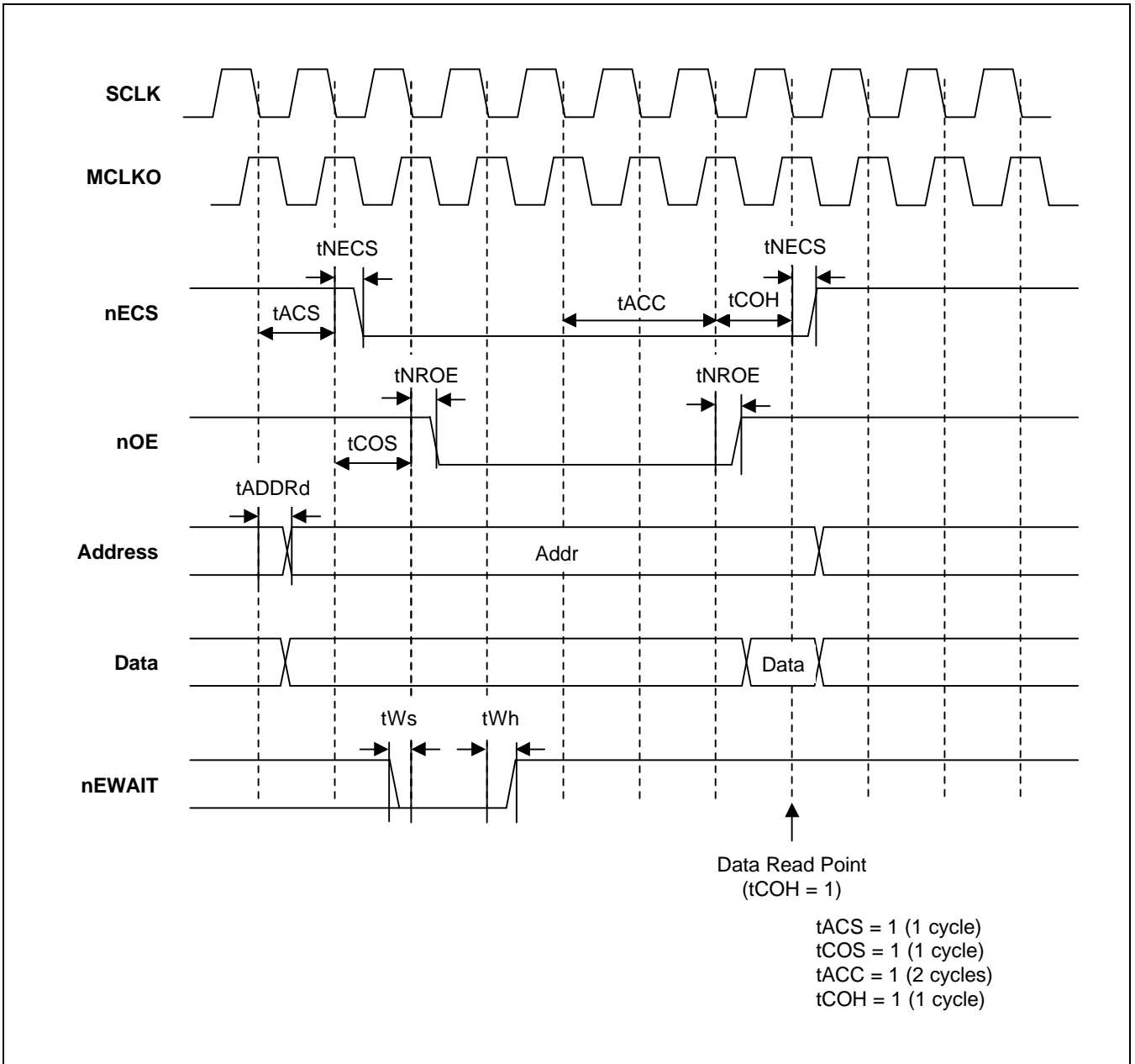

Figure 4-12. External I/O Read Timing 2



**Figure 4-13. External I/O Read Timing with nEWAIT**

The nEWAIT should be valid at the first SCLK falling edge after nOE active. In this case, tCOS and tCOH need to have a minimum of one cycle, and by the setting of tCOS value slower device can be supported. Naimly, nEWAIT valid time depends on tCOS value. Deassertion timing depends on the applied Ext. I/O devices.

When the nEWAIT de-assert, it must be synchronized with MCLKO rising edge.(Because we can not detect SCLK falling edge.) If not, memory state machine can go into the wrong state.

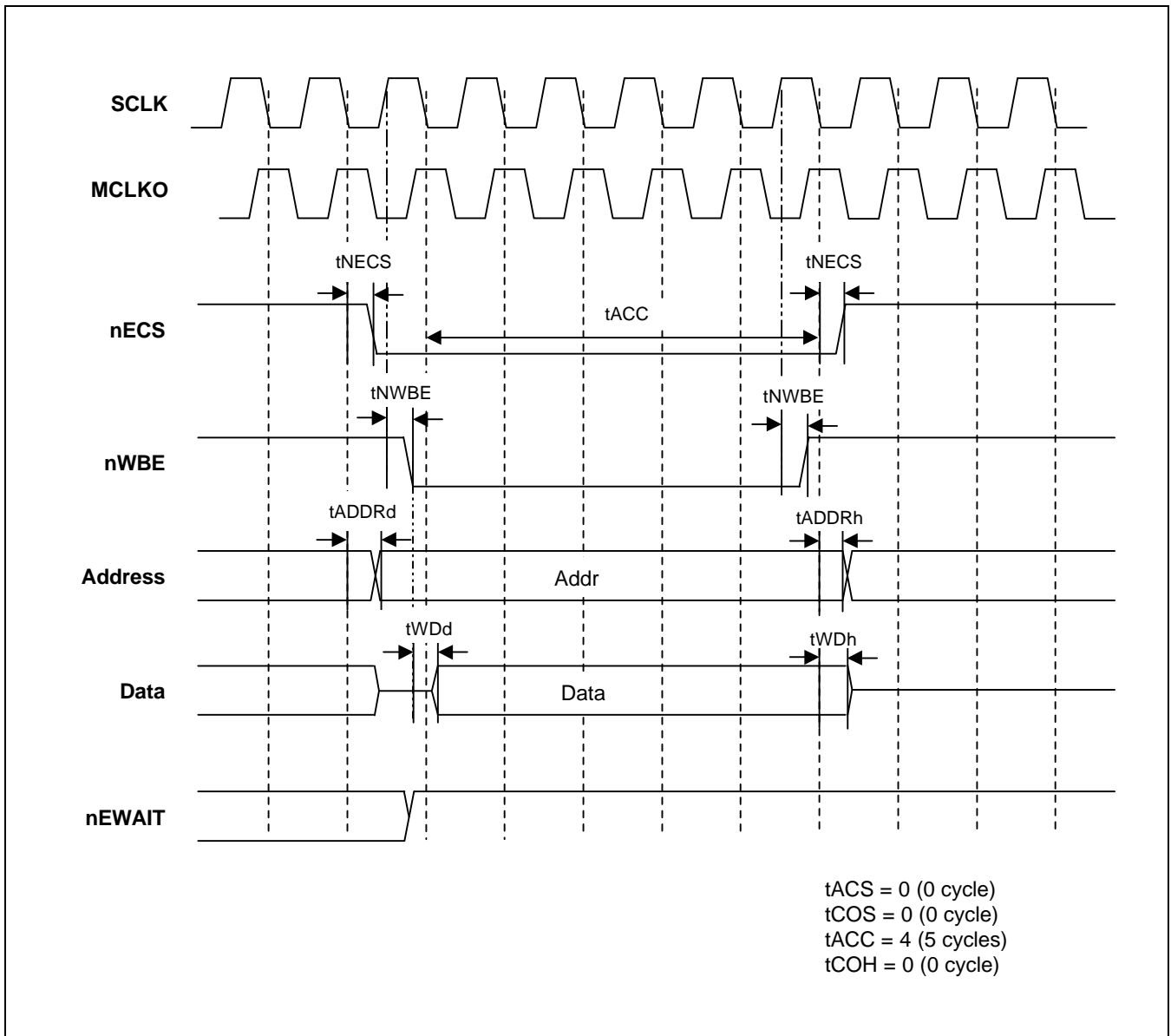

Figure 4-14. External I/O Write Timing 1

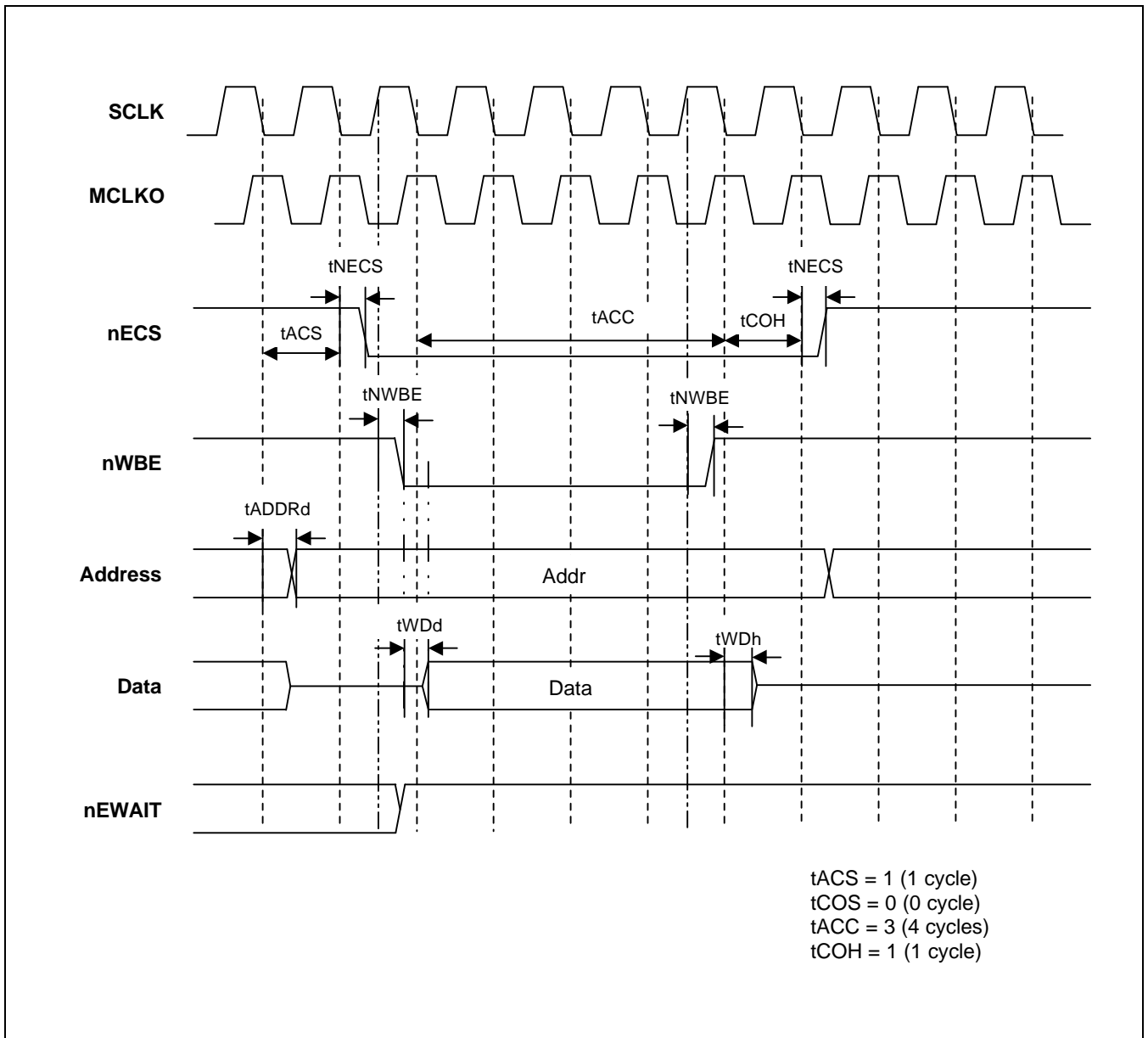

Figure 4-15. External I/O Write Timing 2

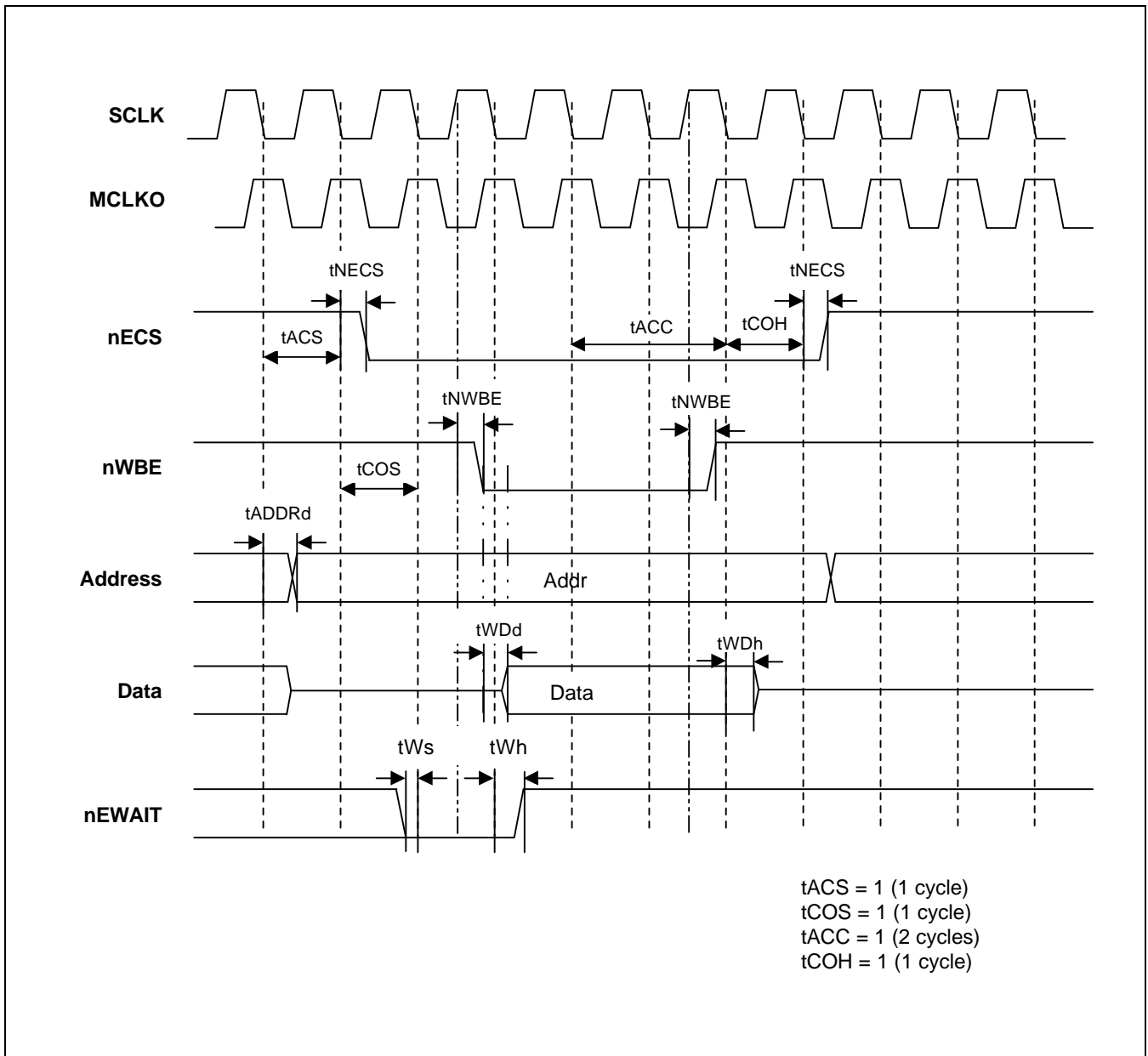

Figure 4-16. External I/O Write Timing with nEWAIT

**DATA BUS WIDTH REGISTER (EXTDBWTH)**

The S3C4510B has interfaces for 8/16/32-bit external ROMs, SRAMs, flash memories, DRAMs, SDRAMs, and external I/O ports. Using data bus width register, you can set the data bus width that is required for specific external memory and external I/O banks.

**NOTE**

In Figure 4-20, the term "Disable" means that the S3C4510B does not generate the access signal for the corresponding external I/O bank.

**Table 4-20. EXTDWTH Register Description**

<b>Registers</b>	<b>Offset</b>	<b>R/W</b>	<b>Description</b>	<b>Reset Value</b>
EXTDBWTH	0x3010	R/W	Data bus width of each bank	0x00000000

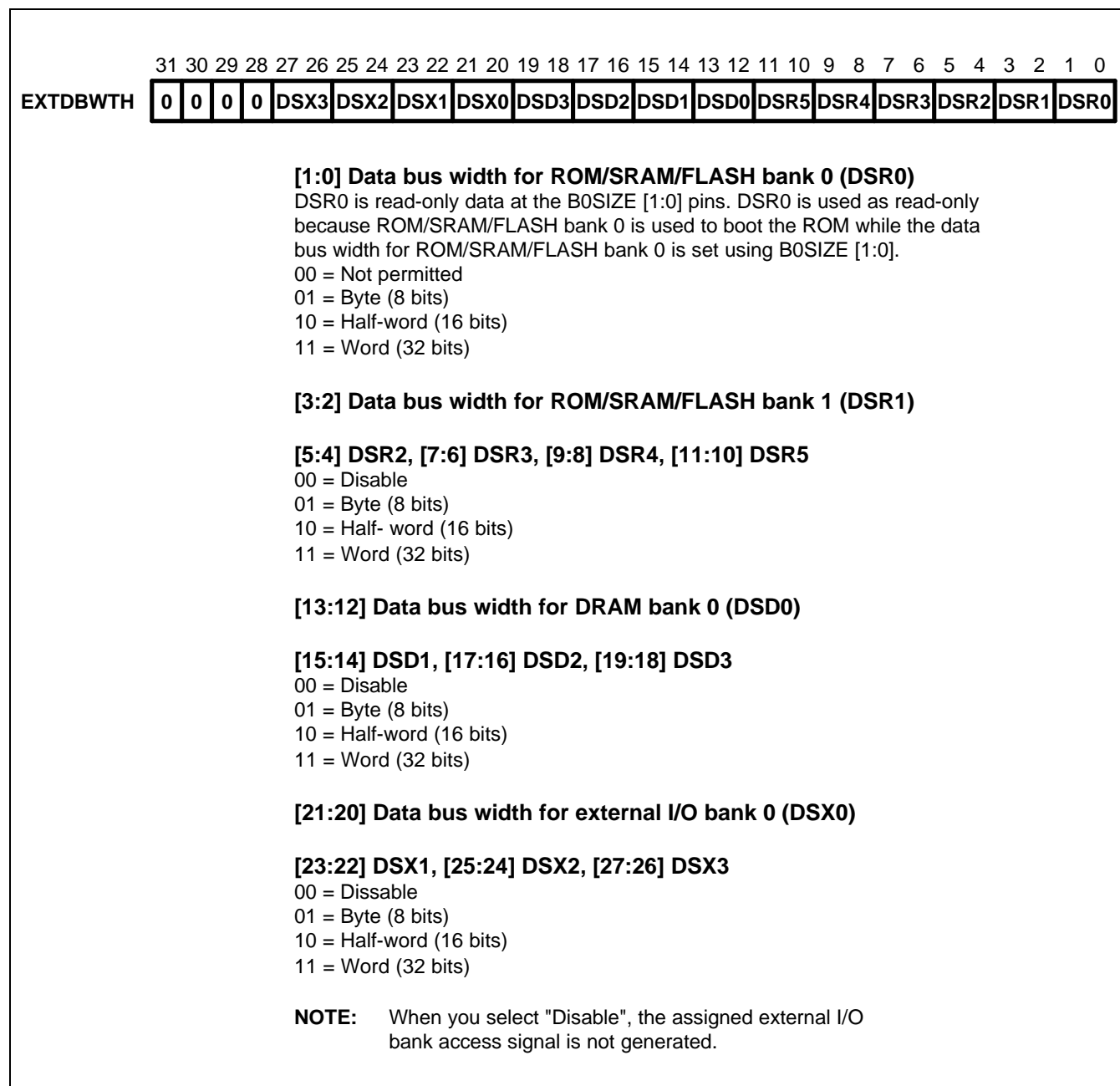

Figure 4-17. Data Bus Width Register (EXTDBWTH)



### ROM/SRAM/FLASH CONTROL REGISTERS (ROMCON)

The System Manager has six control registers for ROM, SRAM, and flash memory (see Table 4-21). These registers correspond to the up to six ROM/SRAM/Flash banks that are supported by S3C4510B.

For ROM/SRAM/Flash bank 0, the external data bus width is determined by the signal at the B0SIZE[1:0] pins:

When B0SIZE[1:0] = "01", the external bus width for ROM/SRAM/Flash bank 0 is 8 bits.

When B0SIZE[1:0] = "10", the external bus width for ROM/SRAM/Flash bank 0 is 16 bits.

When B0SIZE[1:0] = "11", the external bus width for ROM/SRAM/Flash bank 0 is 32 bits.

You can determine the start address of a special register's bank by the value of the corresponding "special register bank base pointer". The control register's physical address is always the sum of the register's bank base pointer plus the register's offset address. (For example, base pointer is 0x3ff0000 and ROMCON0's offset is 0x3014. Then ROMCON0's physical address becomes 0x3ff3014.)

#### NOTE

If you attach SRAM to a ROM/SRAM/Flash bank, you must set the page mode configuration bits, ROMCONn[1:0], in the corresponding control register to "00" (normal ROM).

**Table 4-21. ROM/SRAM/Flash Control Register Description**

Registers	Offset	R/W	Description	Reset Value
ROMCON0	0x3014	R/W	ROM/SRAM/Flash bank 0 control register	0x20000060
ROMCON1	0x3018	R/W	ROM/SRAM/Flash bank 1 control register	0x00000060
ROMCON2	0x301C	R/W	ROM/SRAM/Flash bank 2 control register	0x00000060
ROMCON3	0x3020	R/W	ROM/SRAM/Flash bank 3 control register	0x00000060
ROMCON4	0x3024	R/W	ROM/SRAM/Flash bank 4 control register	0x00000060
ROMCON5	0x3028	R/W	ROM/SRAM/Flash bank 5 control register	0x00000060

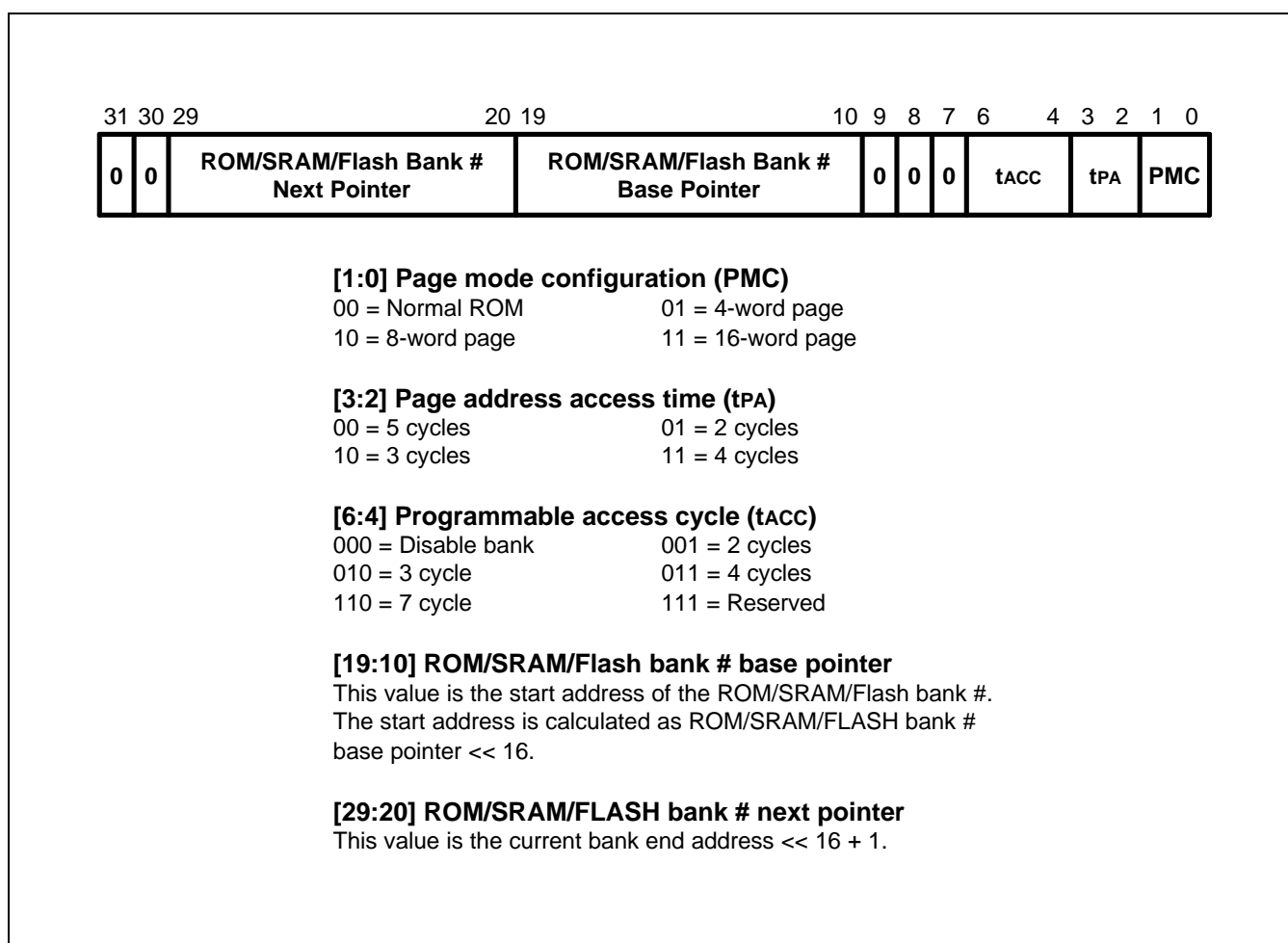

Figure 4-18. ROM/SRAM/FLASH Control Registers (ROMCON0–ROMCON5)

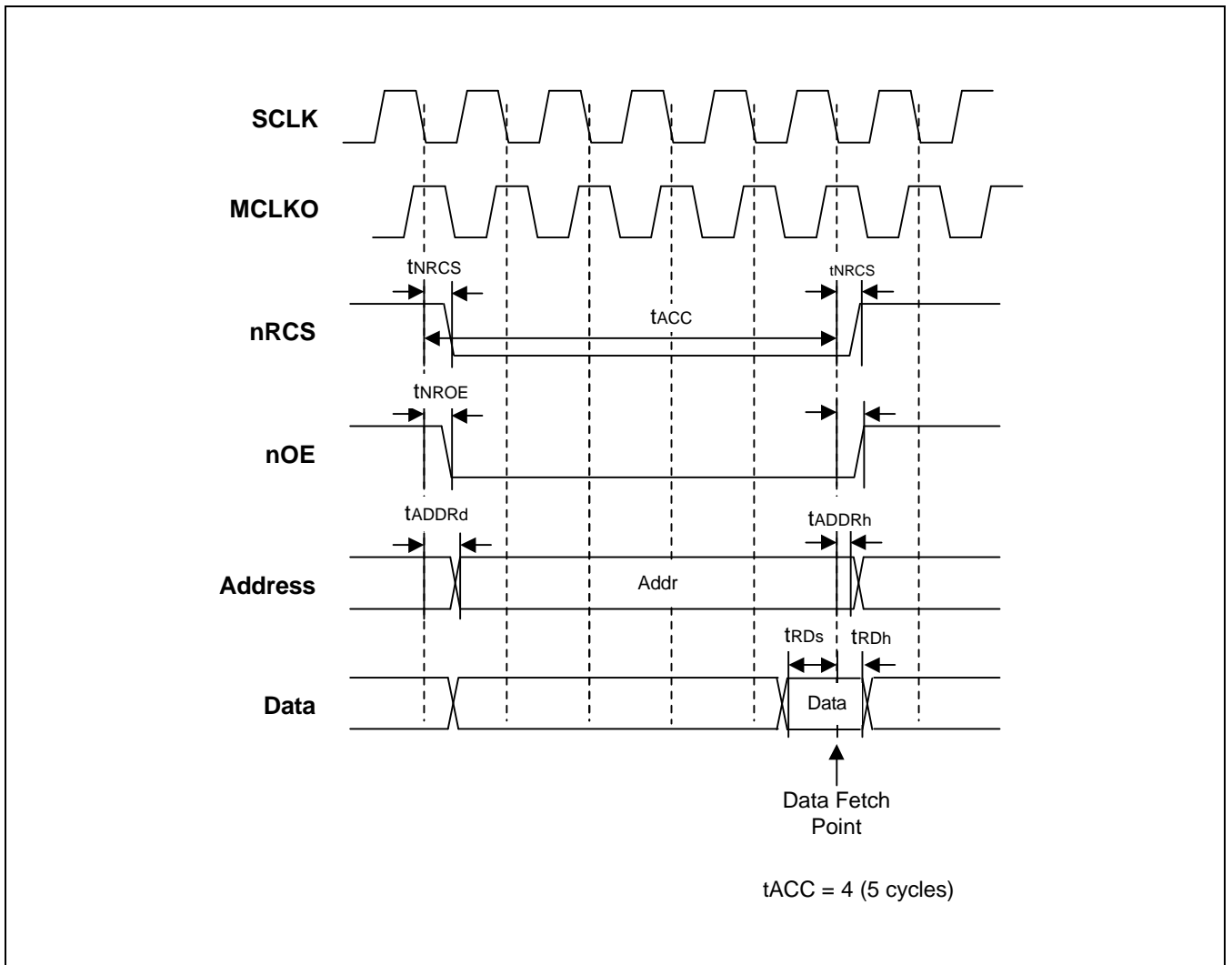

Figure 4-19. ROM/SRAM/Flash Read Access Timing

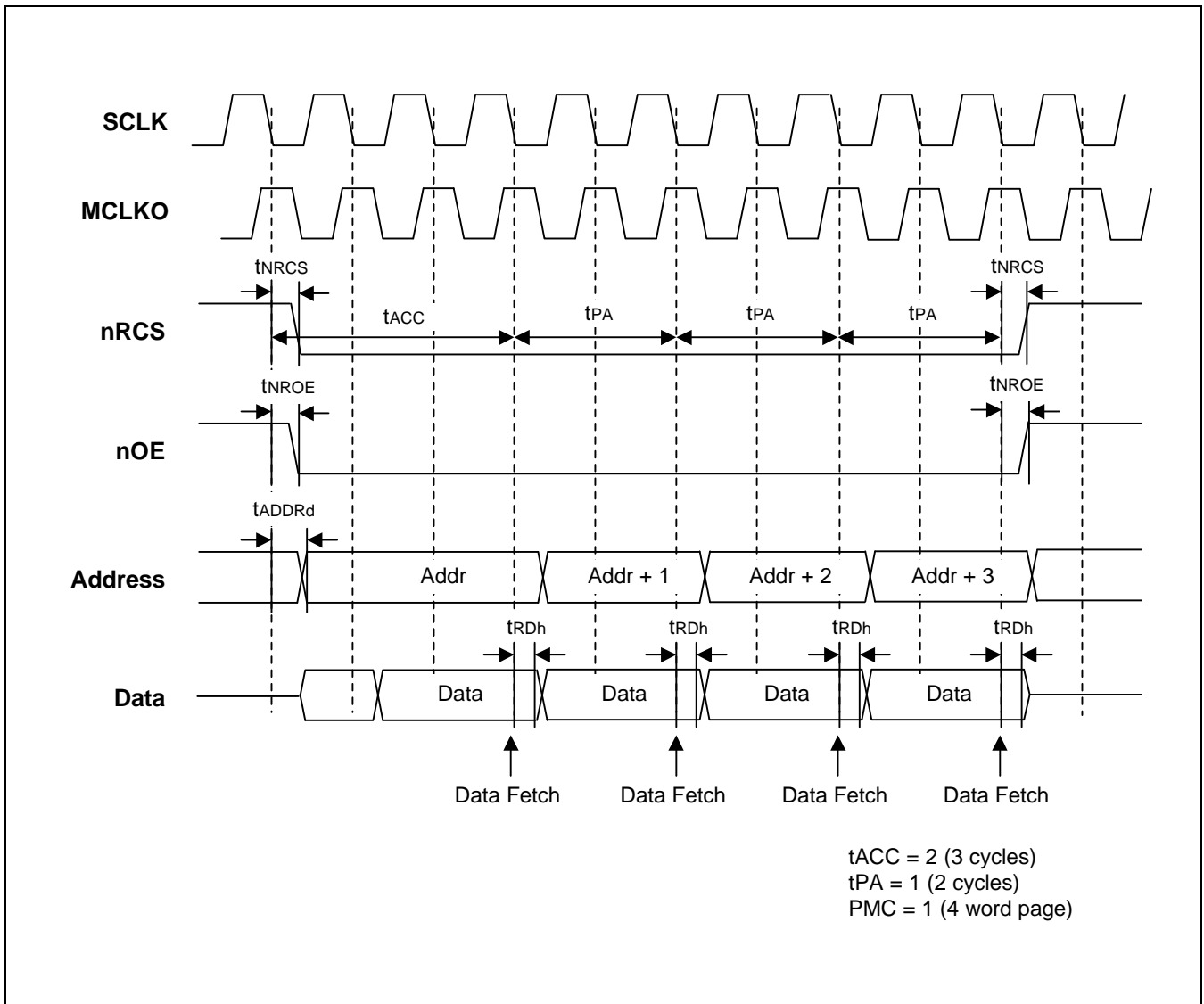

Figure 4-20. ROM/SRAM/Flash Page Read Access Timing

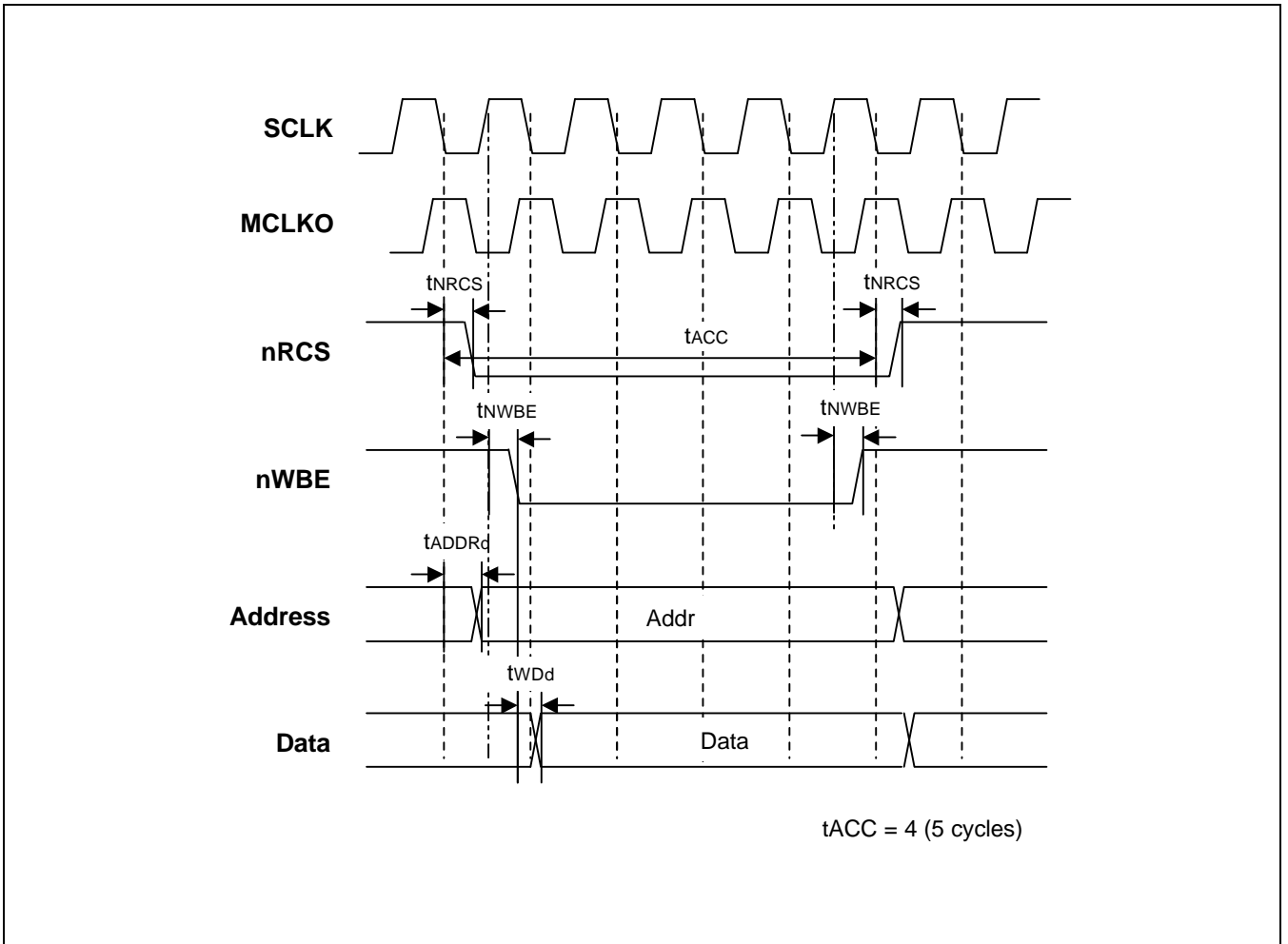

Figure 4-21. ROM/SRAM/Flash Write Access Timing

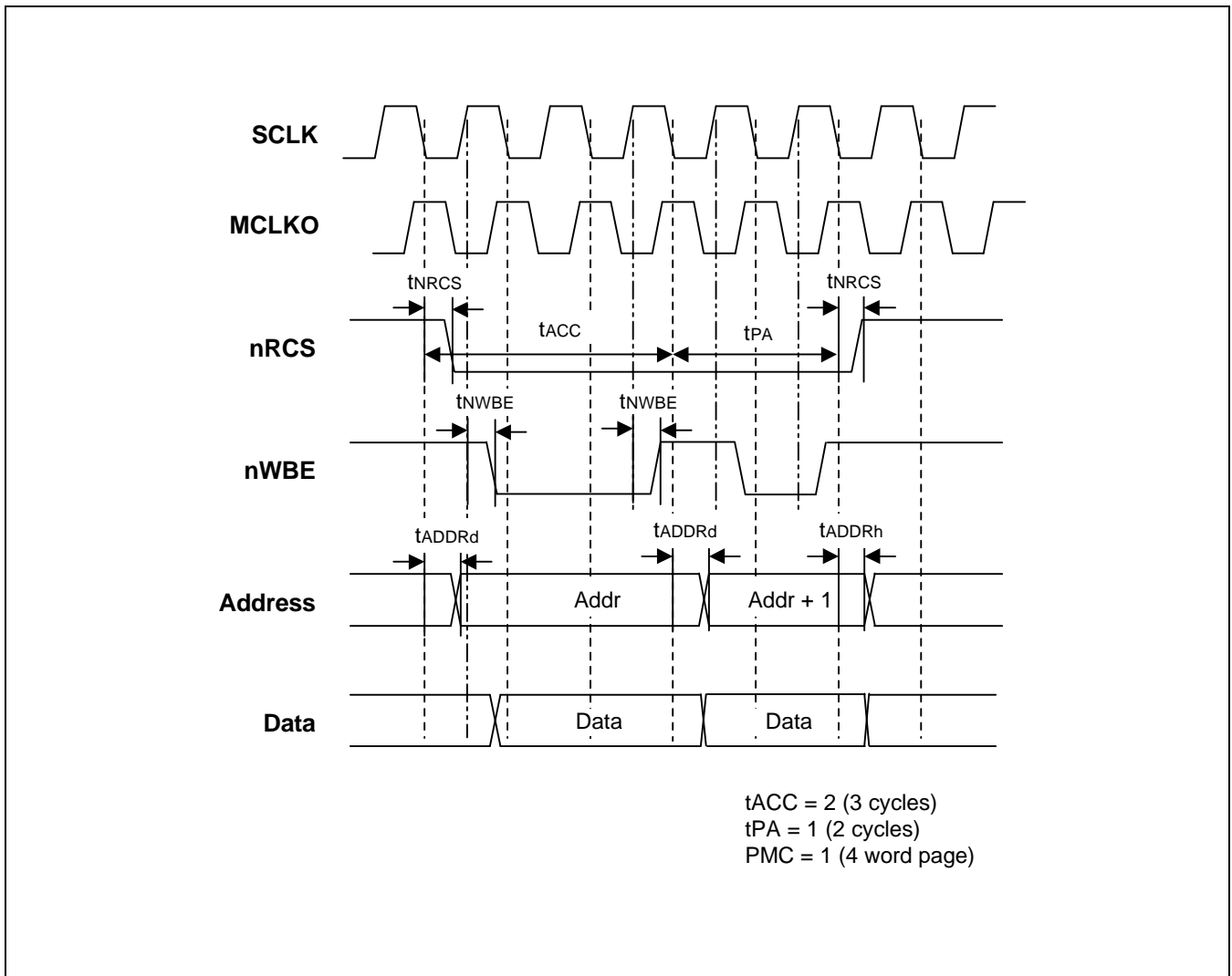

Figure 4-22. ROM/SRAM/Flash Page Write Access Timing

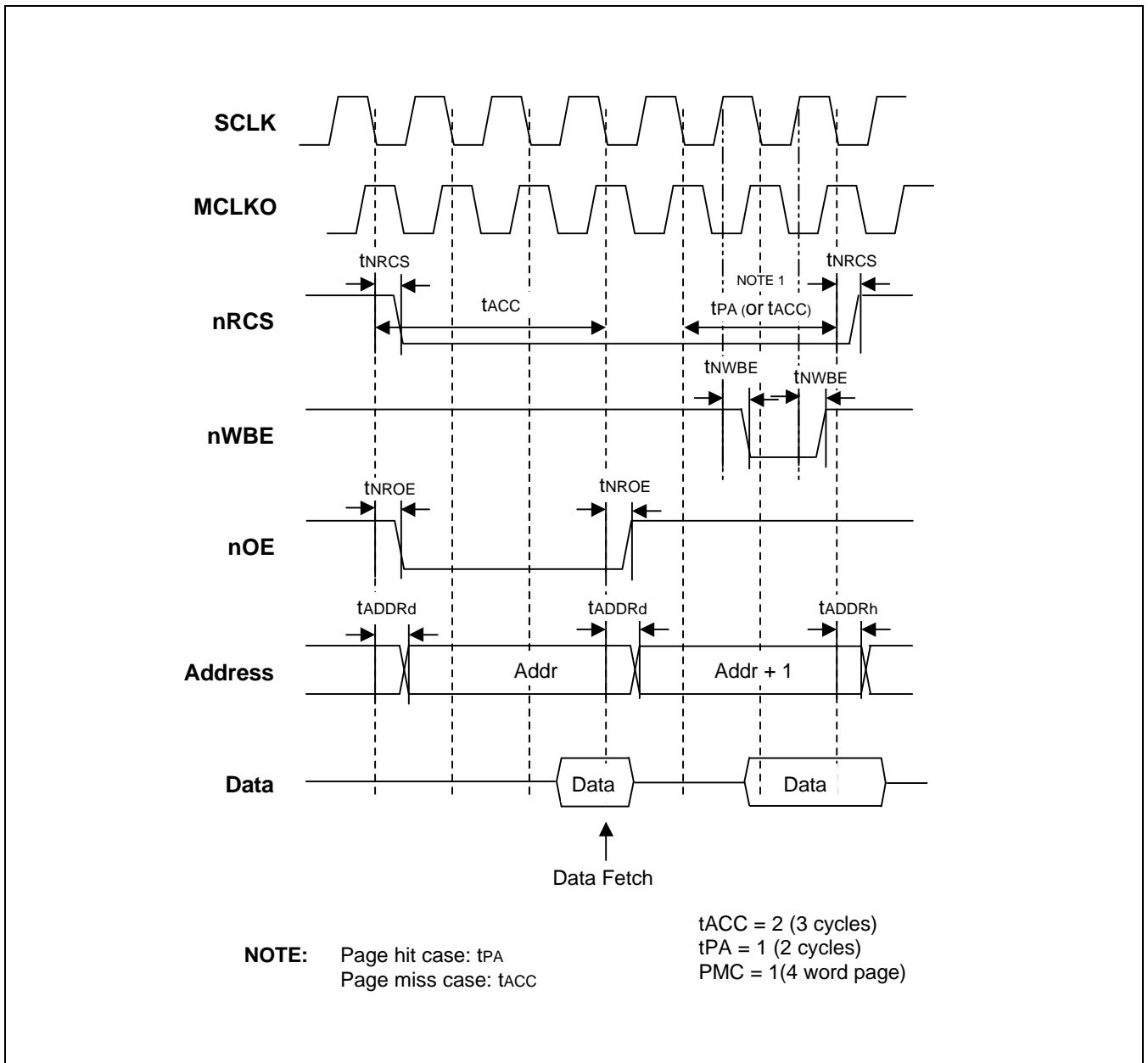

Figure 4-23. ROM/DRAM/Flash Read and Write Access Timing

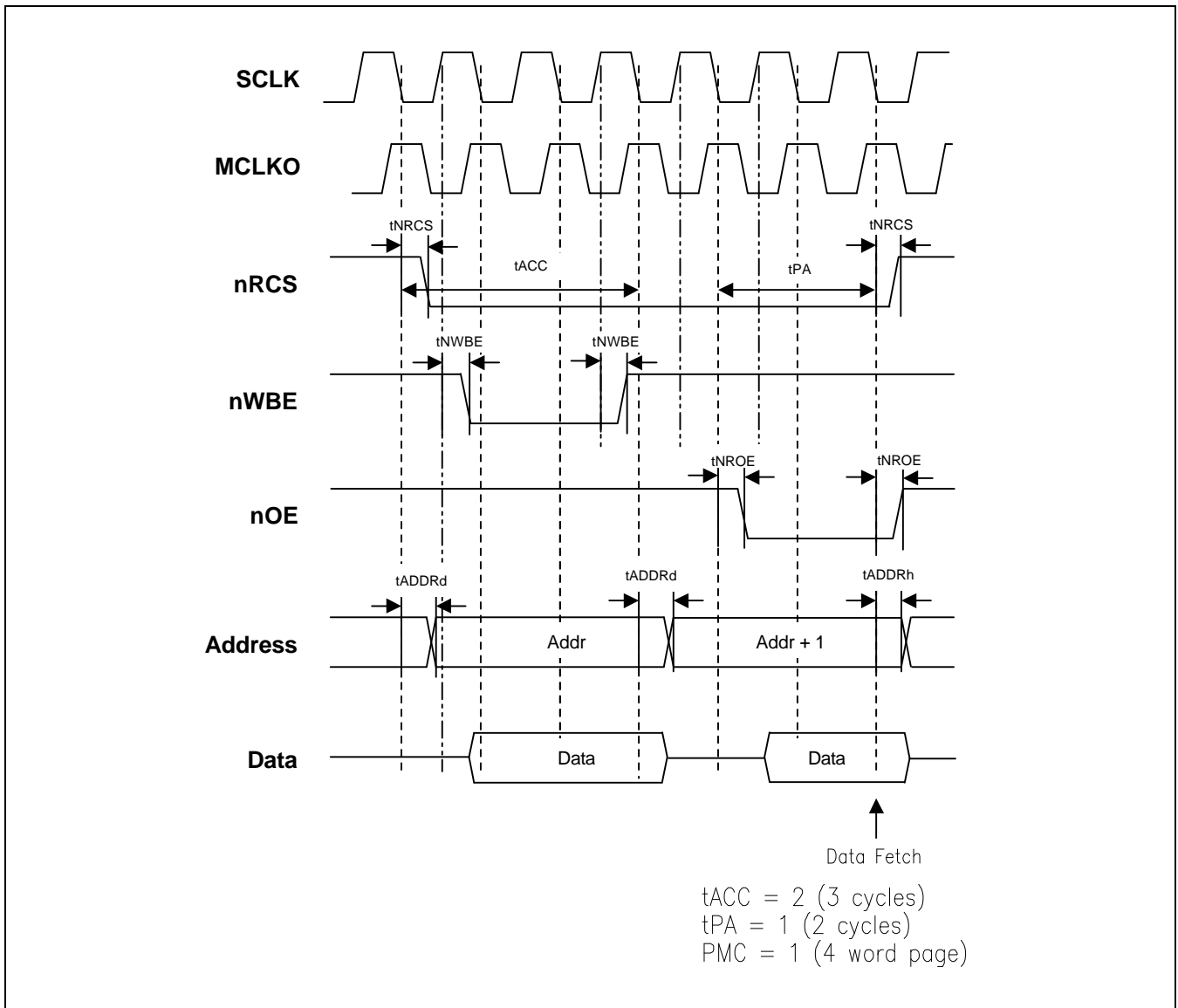

Figure 4-24. ROM/SRAM/Flash Write and Read Access Timing



## ROM BANK 5 ADDRESS/DATA MULTIPLEXED BUS

### Overview

The S3C4510B has separate address and data bus. S3C4510B supports multiplexed address/data bus for low cost chips which require multiplexed bus. To support this feature, the S3C4510B has one special bank (ROM bank 5) which can support address/data multiplexed bus and 4-data burst access by GDMA. For this feature, you should set the MUX enable bit and wait enable bit of CLKCON register.

You can also use ROM bank 5 as normal ROM bank by clearing MUX enable bit of CLKCON register.

When you set the wait enable bit in the CLKCON register, wait cycle can be added by nEWAIT pin for ROM bank 5. Other ROM banks except ROM bank 5 has no effects. nEWAIT pin also can be used to add wait cycle for EXT I/O bank regardless of the wait enable bit.

### Random Access by CPU

At the first cycle of ROM bank 5, address comes out from data bus. Therefore, any device which is connected to the ROM bank 5 can get address. The rest cycle is for data. As the S3C4510B has not a dedicated address strobe signal for address phase in the data burst, you should generate address strobe signal in the application device.

### Four-data Burst Access by GDMA

When you set FB (4-data burst enable) bit in the GDMACON register, the GDMA requests 4-data burst access. When you access ROM bank 5 by 4-data burst mode, the multiplexed ROM bank 5 bus has only one address phase. Therefore, you should internally calculate the address at the data phase. To notify the 4-data burst mode to ROM bank 5 device, the ADDR[21] remains "1" during address phase.

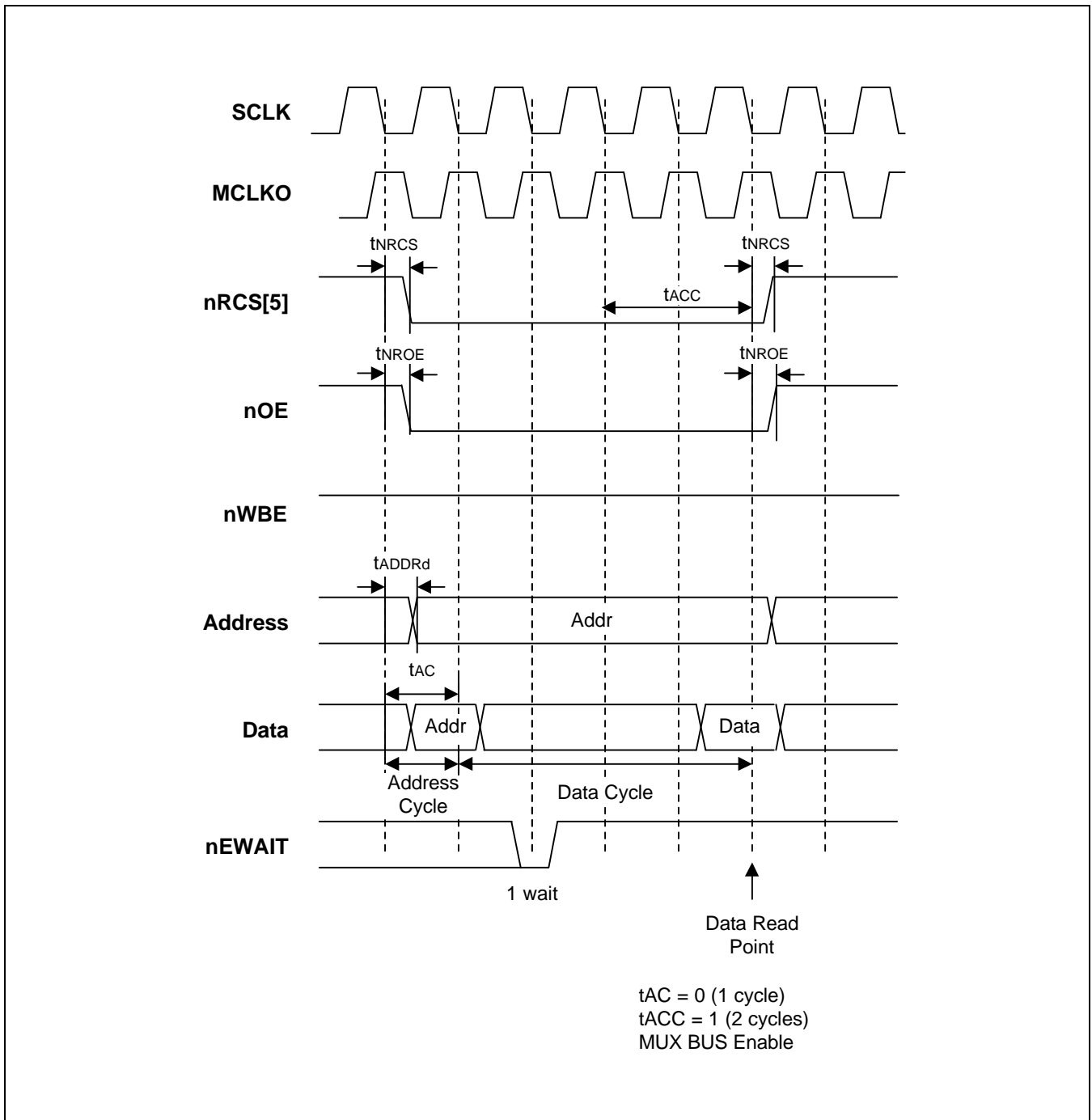

Figure 4-25. ROM/SRAM/FLASH Bank 5 random Read with nEWAIT Access Timing

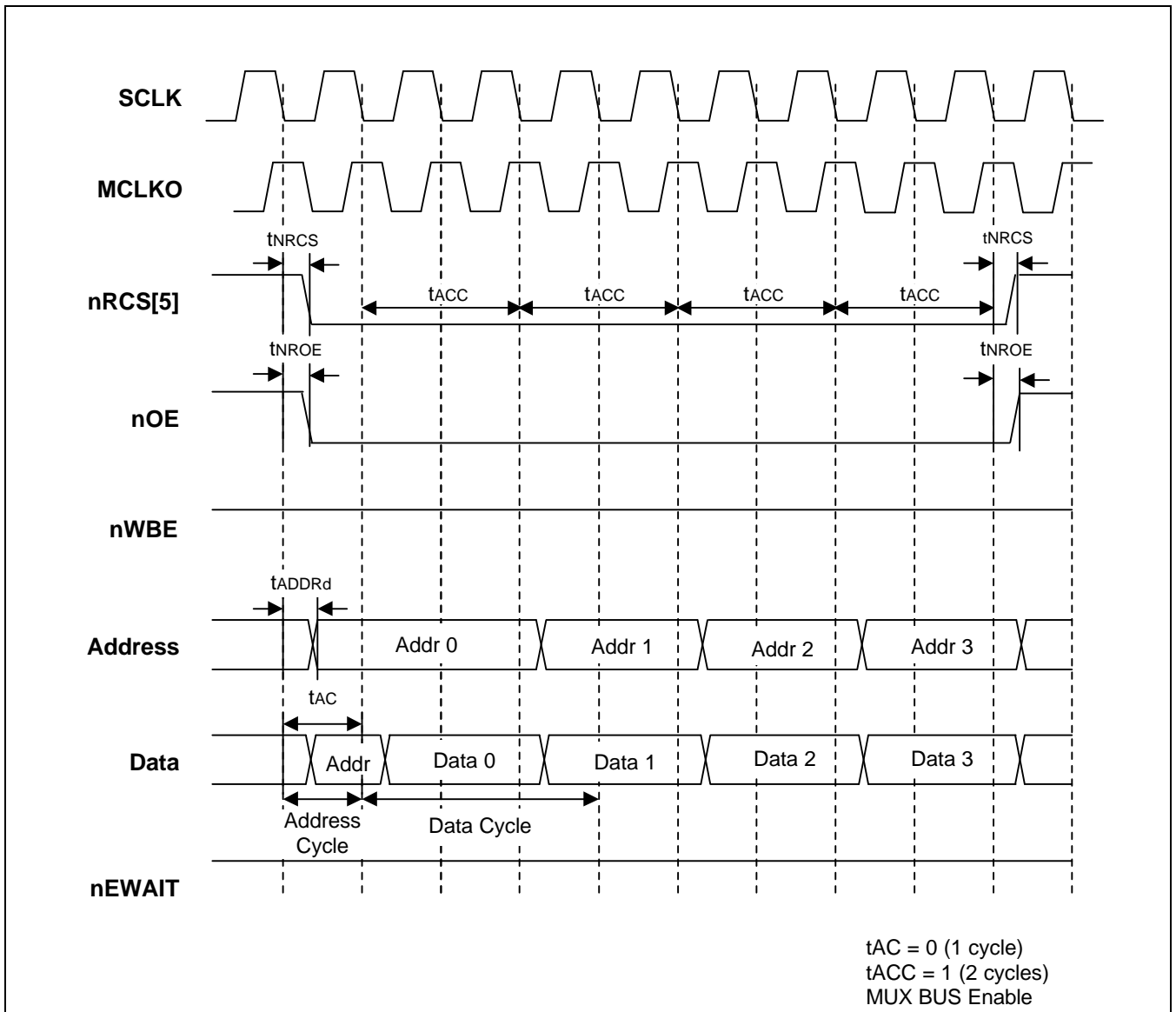

Figure 4-26. ROM/SRAM/FLASH Bank 5 four word burst Read Access Timing When GDMA Request

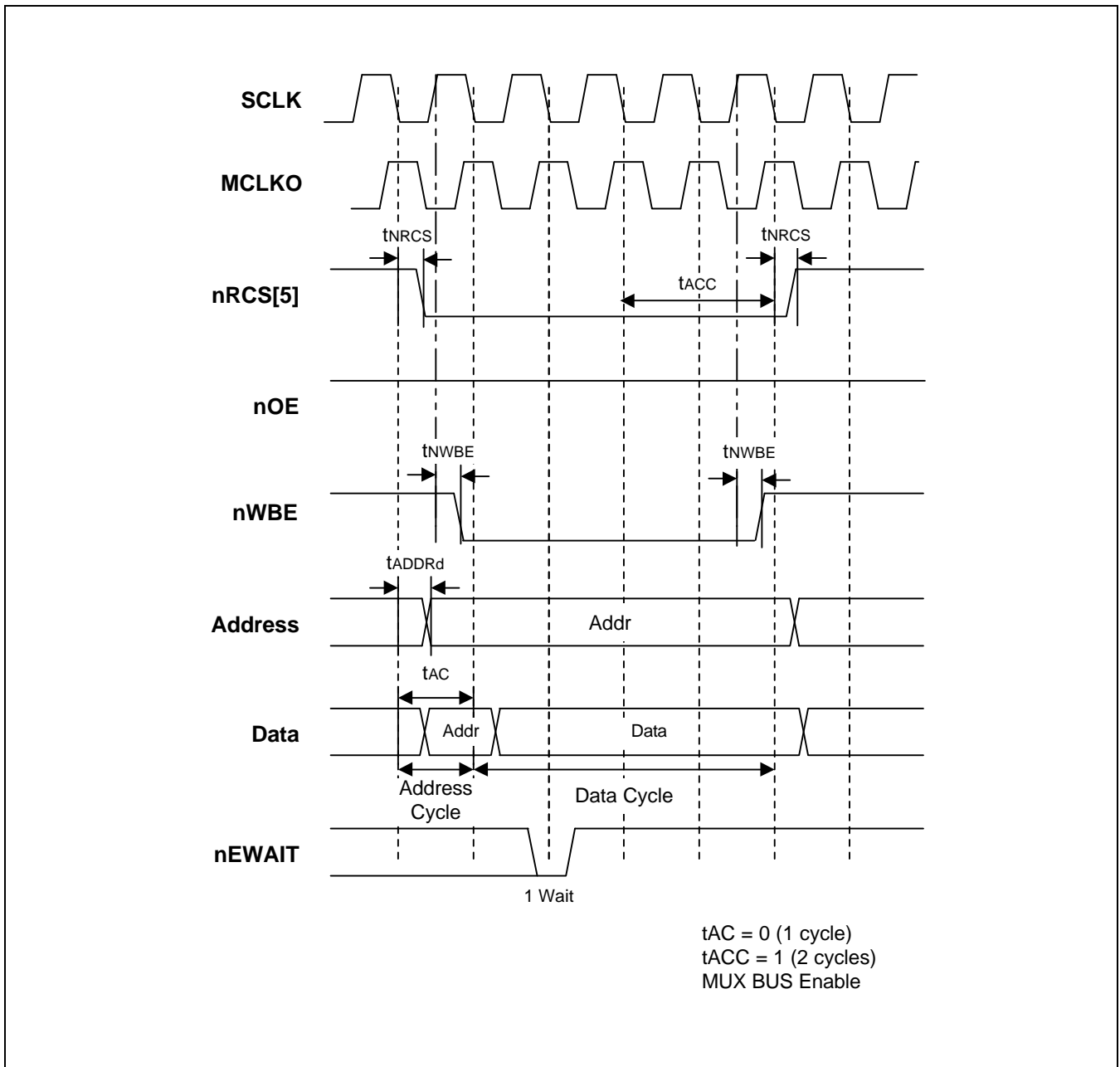

Figure 4-27. ROM/SRAM/FLASH Bank 5 Write Timing with nWAIT Access Timing

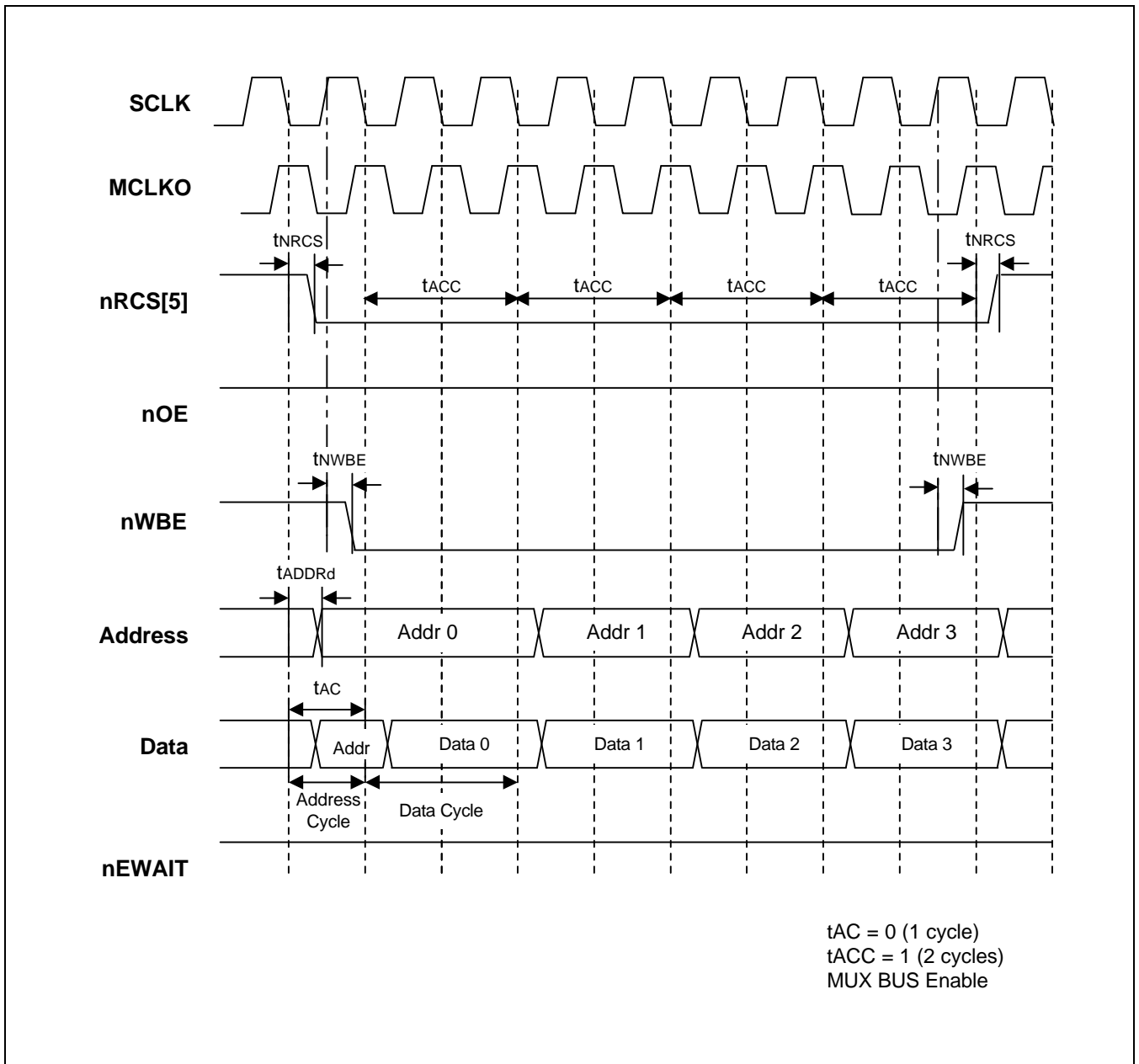

Figure 4-28. ROM/SRAM/FLASH Bank5 Four-data Burst Mode Write Timing When GDMA Requests

## DRAM CONTROL REGISTERS

The System Manager has four DRAM control registers, DRAMCON0–DRAMCON3. These registers correspond to the up to four DRAM banks that are supported by S3C4510B. A fifth register, REFEXTCON, is used to set the base pointer for external I/O bank 0.

S3C4510B supports EDO, normal, Synchronous DRAM(SDRAM). SDRAM mode can be selected by setting SYSCFG[31]. If this bit is set to '1', all DRAM banks are selected SDRAM. Otherwise, EDO/FP DRAM banks are selected.

**Table 4-22. DRAM and External I/O Control Register Description**

Registers	Offset	R/W	Description	Reset Value
DRAMCON0	0x302C	R/W	DRAM bank 0 control register	0x00000000
DRAMCON1	0x3030	R/W	DRAM bank 1 control register	0x00000000
DRAMCON2	0x3034	R/W	DRAM bank 2 control register	0x00000000
DRAMCON3	0x3038	R/W	DRAM bank 3 control register	0x00000000
REFEXTCON	0x303C	R/W	Refresh and external I/O control register	0x00000000



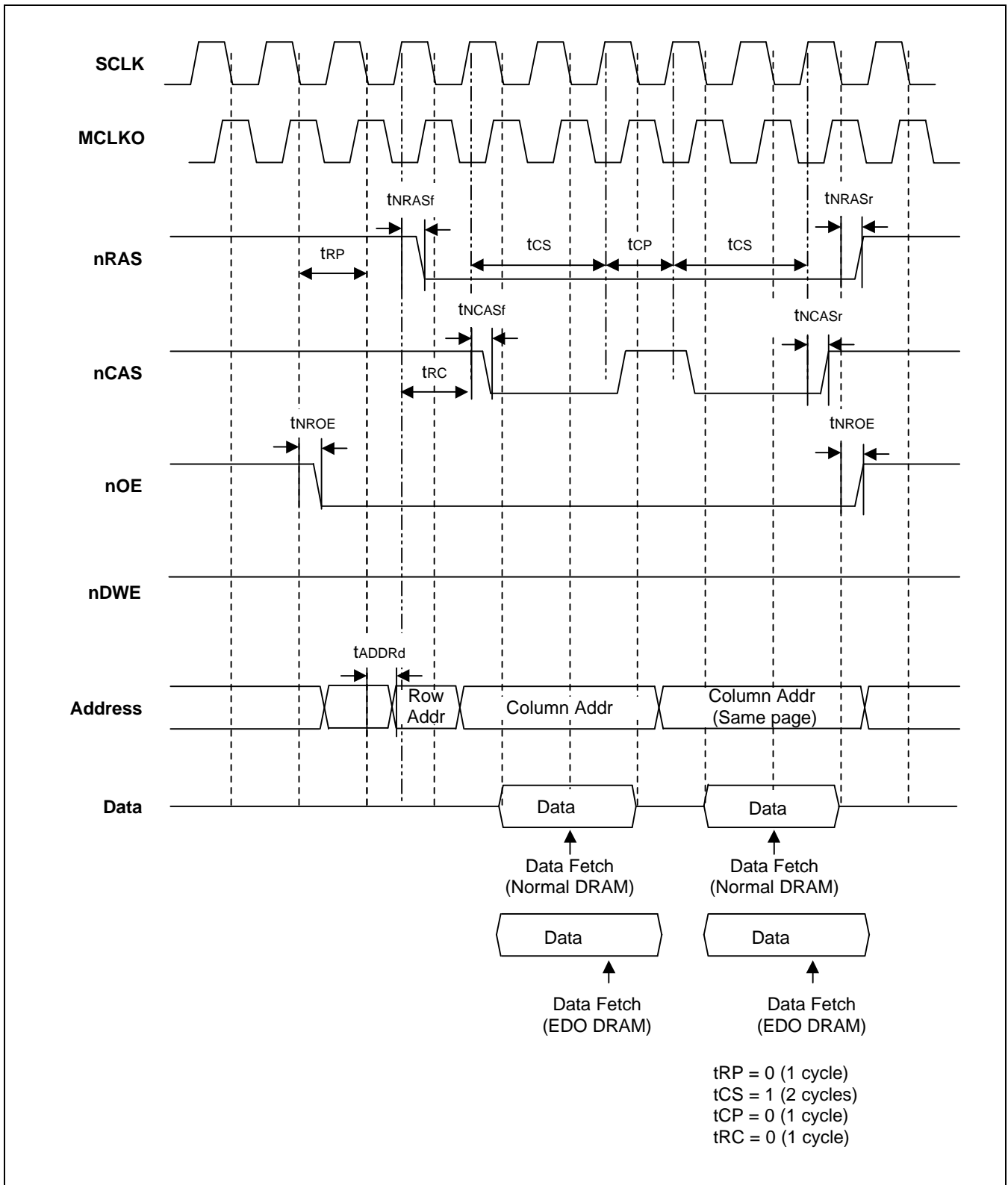

Figure 4-30. EDO/FP DRAM Bank Read Timing (Page Mode)



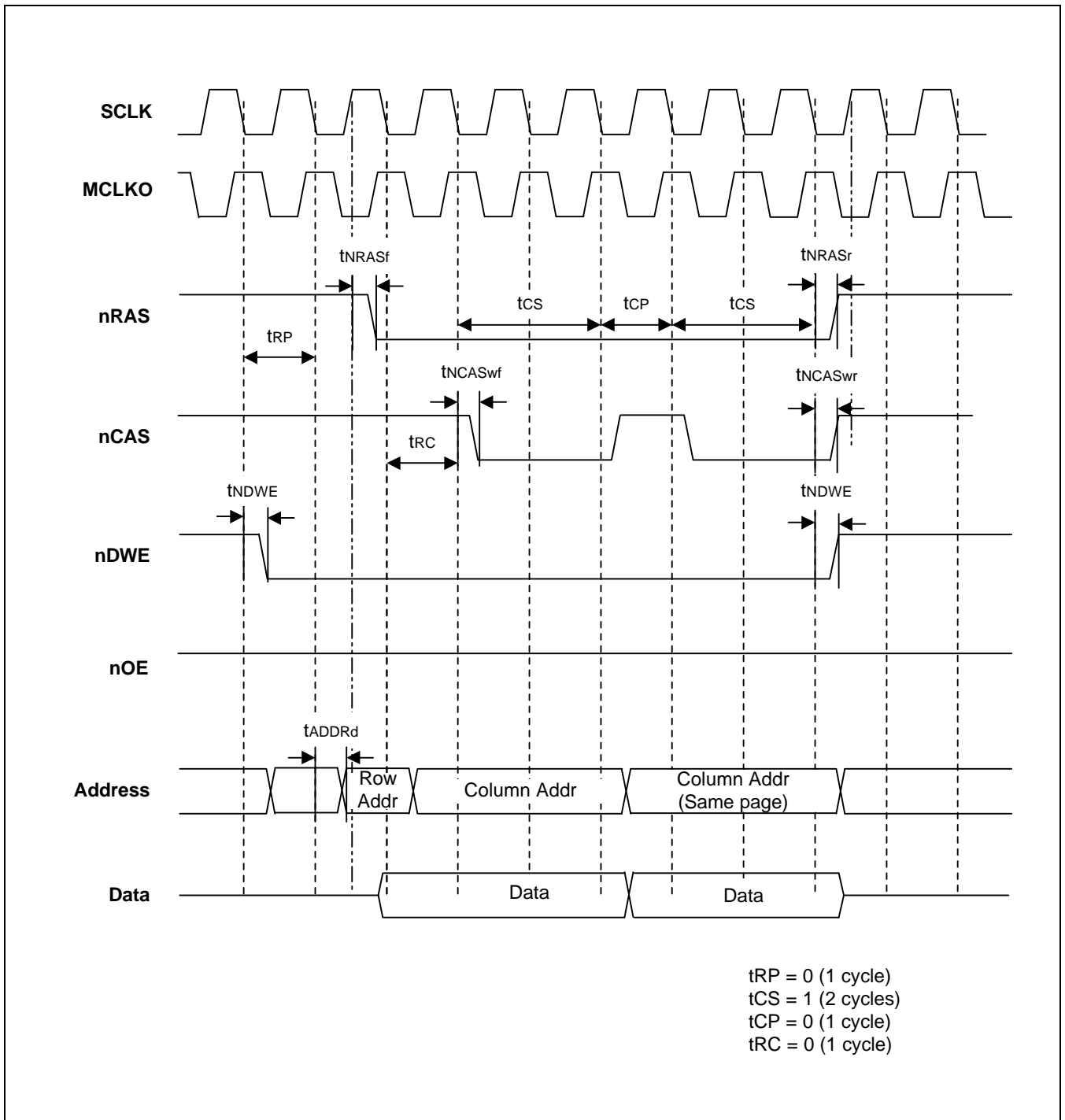

Figure 4-31. EDO/FP DRAM Bank Write Timing (Page Mode)

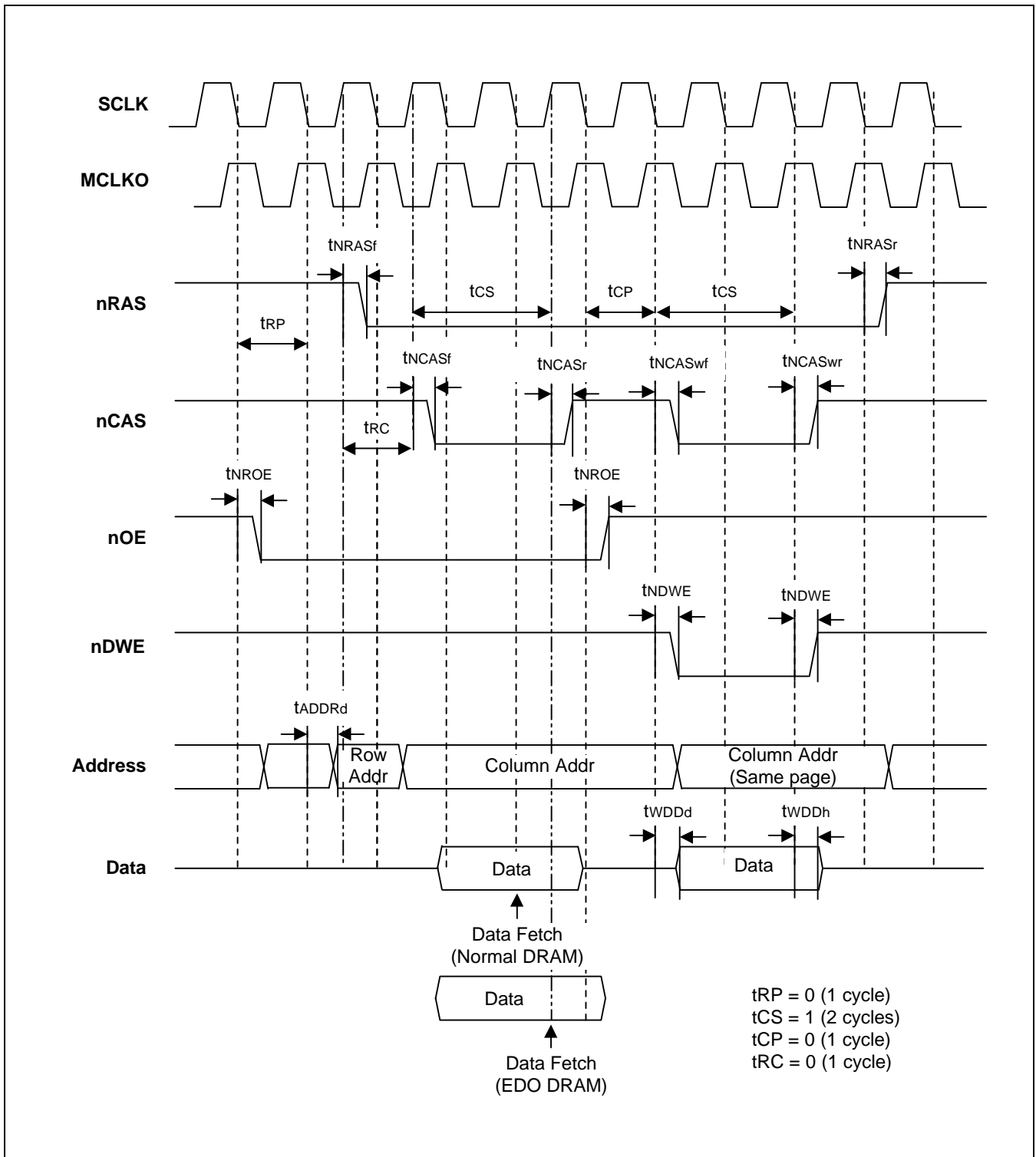

Figure 4-32. EDO/FP DRAM Bank Read and Write Timing (Page Mode)

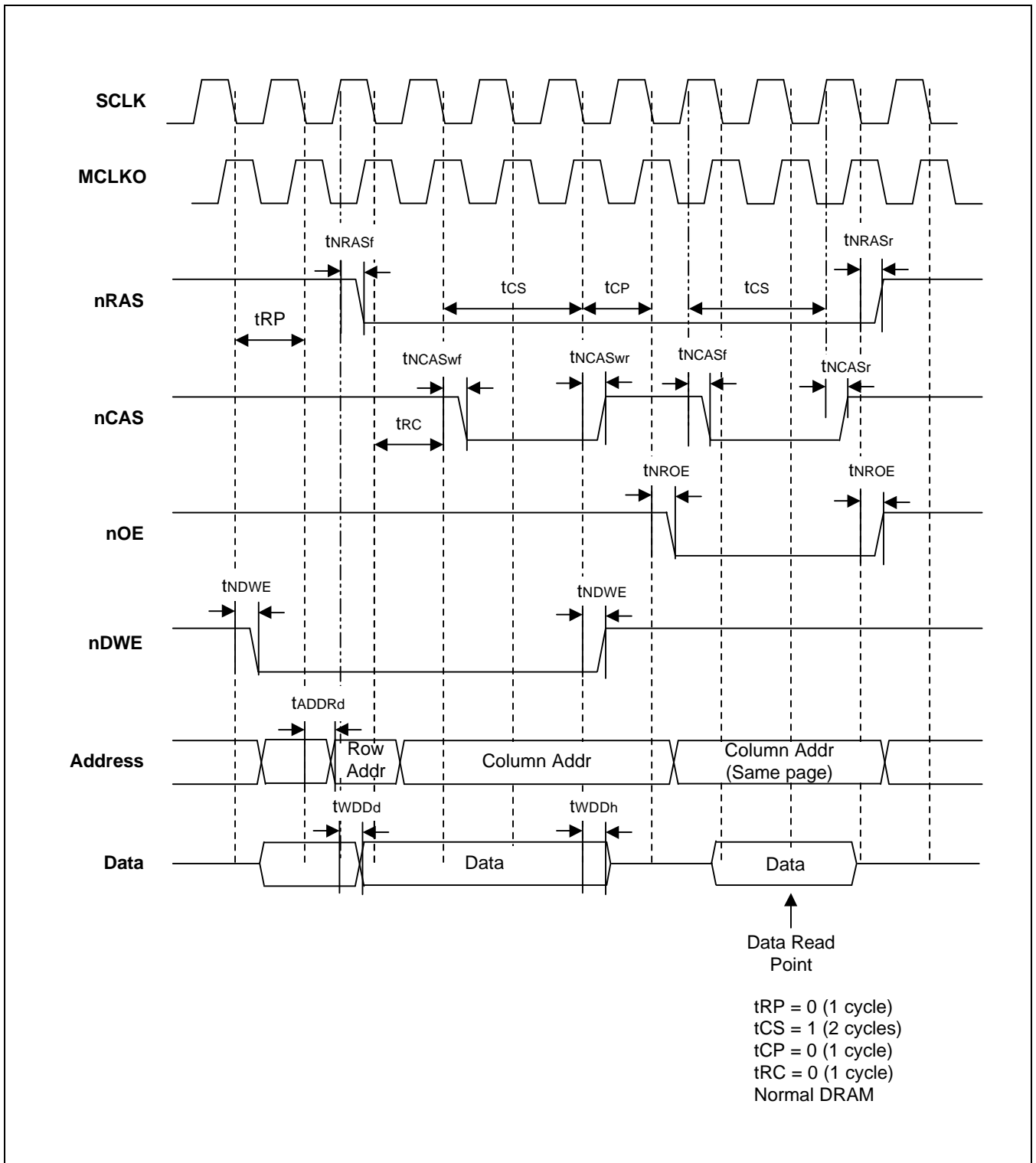

Figure 4-33. EDO/FP DRAM Bank Write and Read Timing (Page Mode)

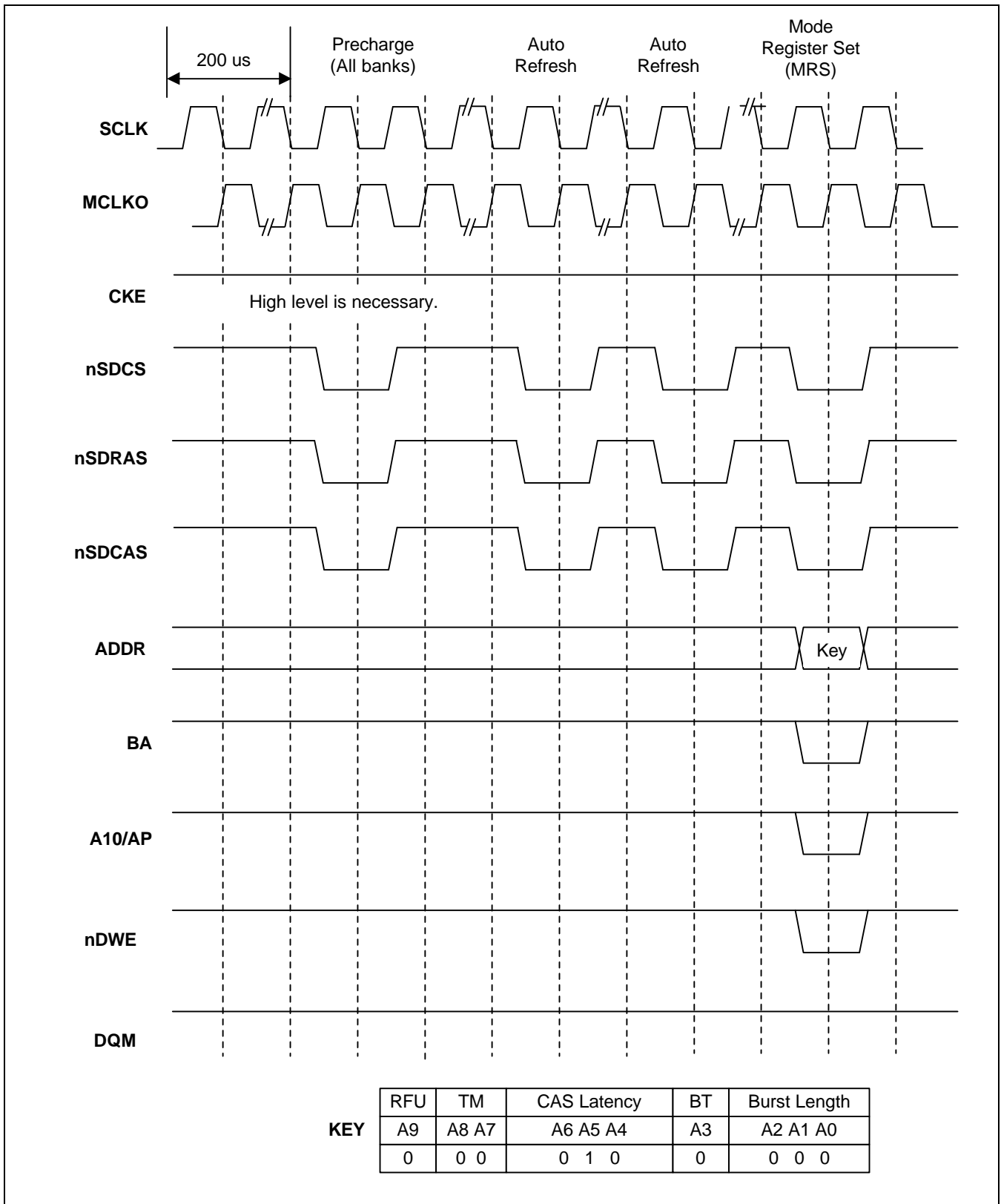

Figure 4-34. SDRAM Power-up Sequence

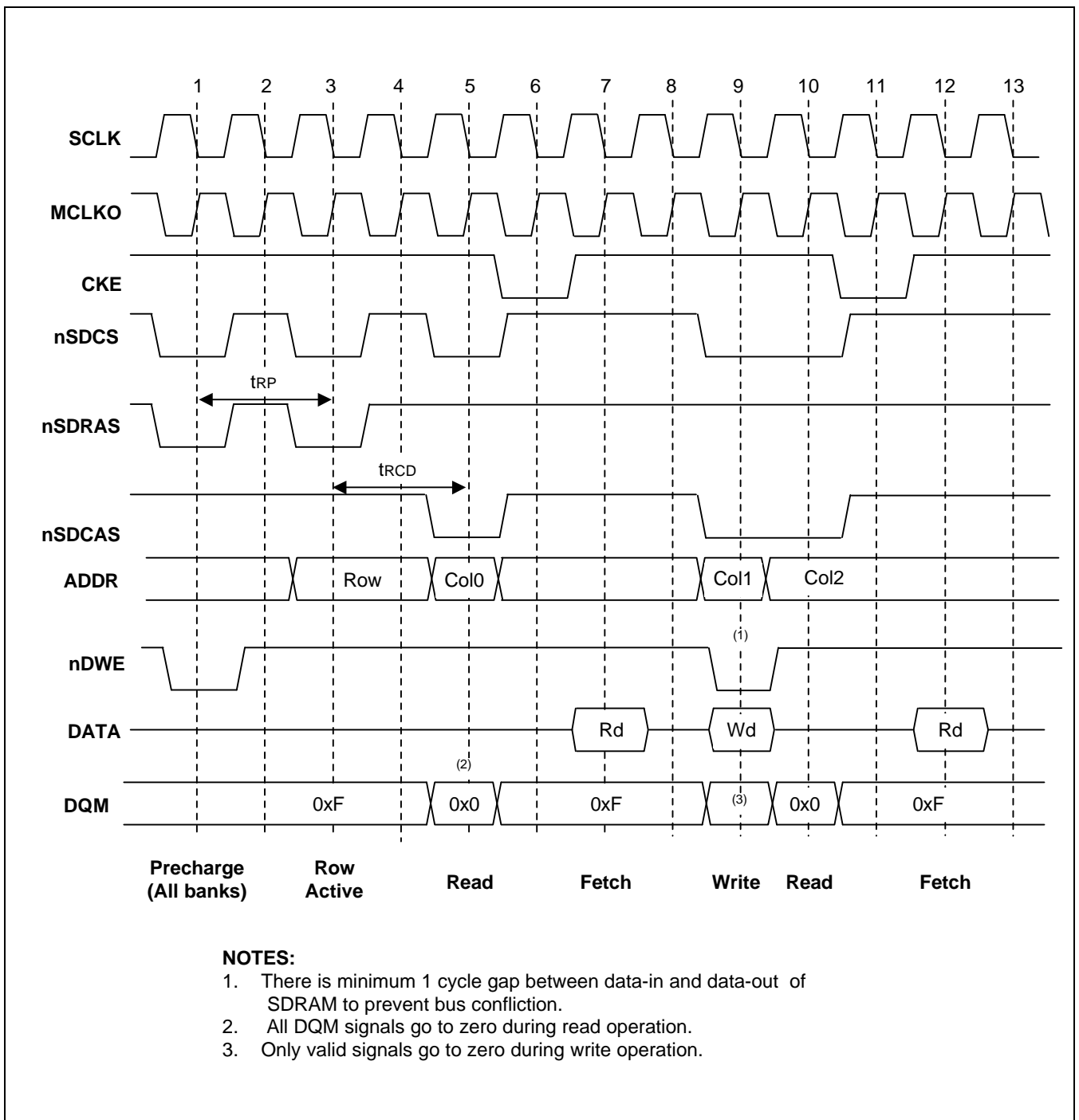

Figure 4-35. Non-burst, Read-Write-Read Cycles @CAS Latency = 2, Burst Length = 1

## DRAM INTERFACE FEATURES

The S3C4510B provides a fully programmable external DRAM interface. You can easily modify the characteristics of this interface by manipulating the corresponding DRAM control registers. Programmable features include

- External data bus width
- Control fast page or EDO mode by DRAMCON[0]
- Select fast page/EDO mode or SDRAM mode by SYSCFG
- Number of access cycles for each DRAM bank, and
- CAS strobe time, CAS precharge time, RAS to CAS delay, RAS pre-charge time

The refresh and external I/O control register, REFEXTCON, controls DRAM refresh operations and external I/O bank accesses. The S3C4510B eliminates the need for an external refresh signal by automatically issuing an internal CAS-before-RAS refresh or auto-refresh control signal.

The S3C4510B generates row and column addresses for DRAM accesses with 23-bit internal address bus. It also supports symmetric or asymmetric DRAM addressing by changing the number of column address lines from 8 to 11.

### EDO Mode DRAM Accesses

The timing for accessing a DRAM in EDO mode is comparable to DRAM accesses in normal fast page mode. However, in EDO mode, the S3C4510B CPU fetches data (when read) one-half clock later than in normal fast page mode. This is possible because EDO mode can validate the data even if CAS goes High when RAS is Low. In this way, gives the CPU sufficient time to access and latch the data so that the overall memory access cycle time can be reduced.

### Synchronous DRAM Accesses

Synchronous DRAM interface features are as follows:

- MRS cycle with address key program
  - CAS latency (2 cycles)
  - Burst length (1)
  - Burst type (Sequential)
- Auto refresh
- SDRAM interface signal: CE, SDCLK, nSDCS[3:0], nSDCAS, nSDRAS, DQM[3:0], ADDR[10]/AP

The address bits except row and column address among the 23-bit internal address bus can be assigned to Bank select address(BA) for SDRAM.

See the SDRAM interface example, Figure 4-36.

## Available Samsung SDRAM Components for S3C4510B

### Components

S3C4510B can support below SDRAM configuration for 1 bank.

- 2MBytes to 1 bank → 1 × (2Mx32 with 4banks)
- 4MBytes to 1 bank → 2 × (1Mx16 with 2banks)
- 8MBytes to 1 bank → 4 × (2Mx8 with 2banks)
- 16MBytes to 1bank → 2 × (4Mx16 with 2/4banks)
- 32MBytes to 1bank → 4 × (8Mx8 with 2/4banks)

You can select any combination among them.

SDRAM components that are available are as follow.

x4 SDRAM whose capacity is larger than 16M SDRAM is not supported at S3C4510B.

#### 16M bit SDRAM

- |                                 |                   |
|---------------------------------|-------------------|
| — 4Mx4 with 2banks (Supported)  | RA0–RA10, CA0–CA9 |
| — 2Mx8 with 2banks (Supported)  | RA0–RA10, CA0–CA8 |
| — 1Mx16 with 2banks (Supported) | RA0–RA10, CA0–CA7 |

#### 64M bit 2Banks SDRAM

- |                                     |                   |
|-------------------------------------|-------------------|
| — 16Mx4 with 2banks (not supported) | RA0–RA12, CA0–CA9 |
| — 8Mx8 with 2banks (supported)      | RA0–RA12, CA0–CA8 |
| — 4Mx16 with 2banks (supported)     | RA0–RA12, CA0–CA7 |

#### 64M bit 4Banks SDRAM

- |                                     |                   |
|-------------------------------------|-------------------|
| — 16Mx4 with 4banks (not supported) | RA0–RA11, CA0–CA9 |
| — 8Mx8 with 4banks (supported)      | RA0–RA11, CA0–CA8 |
| — 4Mx16 with 4banks (supported)     | RA0–RA11, CA0–CA7 |

#### 2Mx32 (64M bit) SDRAM

- |                                 |                   |
|---------------------------------|-------------------|
| — 2Mx32 with 4banks (supported) | RA0–RA10, CA0–CA7 |
|---------------------------------|-------------------|

### 100 Pin DIMM Module SDRAM

#### KMM330S104CT

- |  |                   |
|--|-------------------|
| — 1Mx32 based on 2 1Mx16 2banks components | RA0–RA10, CA0–CA7 |
|--|-------------------|

#### KMM330S204CT

- |  |                   |
|--|-------------------|
| — 4Mx32 based on 4 1Mx16 2banks components | RA0–RA10, CA0–CA7 |
|--|-------------------|

#### KMM330S2424CT

- |   |                   |
|---|-------------------|
| — 4Mx32 based on 2 4Mx16 4banks componets | RA0–RA11, CA0–CA7 |
|---|-------------------|

#### KMM330S824CT

- |   |                   |
|---|-------------------|
| — 8Mx32 based on 4 4Mx16 4banks componets | RA0–RA11, CA0–CA7 |
|---|-------------------|

## Relationship Between CAN (Column Address Number) and Address MUX Output for SDRAM

Table 4-23. CAN and Address MUX Output

CAN	Output Timing	External Address Pins (ADDR)								
		[21:15]	14	13	12	11	10	9	8	7-0
00	Column address	x	A22	A21	A20	A19	A10/AP	A9	A8	A7-A0
	Row address	x	A22	A21	A20	A19	A18	A17	A16	A15-A8
01	Column address	x	0	A22	A21	A20	A10/AP	A9	A8	A7-A0
	Row address	x	0	A22	A21	A20	A19	A18	A17	A16-A9
10	Column address	x	0	0	A22	A21	A10/AP	A9	A8	A7-A0
	Row address	x	0	0	A22	A21	A20	A19	A18	A17-A10

**NOTES:**

1. A22 to A0 depends on external bus width. In case of x32 memory, A[22:0] is word address.
2. A[22:0] consists of: Bank Address + Valid Row Address + Valid Column Address

**DRAM BANK SPACE**

The S3C4510B DRAM interface supports four DRAM banks. Each bank can have a different configuration. You use the DRAM control registers, DRAMCON0-DRAMCON3, to program the DRAM access cycles and memory bank locations.

Each DRAM control register has two 10-bit address pointers, one base pointer and one next pointer, to denote the start and end address of each DRAM bank. The 10-bit pointer values are mapped to the address [25:16]. This gives each bank address an offset value of 64 K bytes (16 bits). The next pointer value will be the DRAM bank's end address + 1.

**System Initialization Values**

When the system is initialized, the four DRAM control registers are initialized to 00000000H, disabling all external DRAMs.



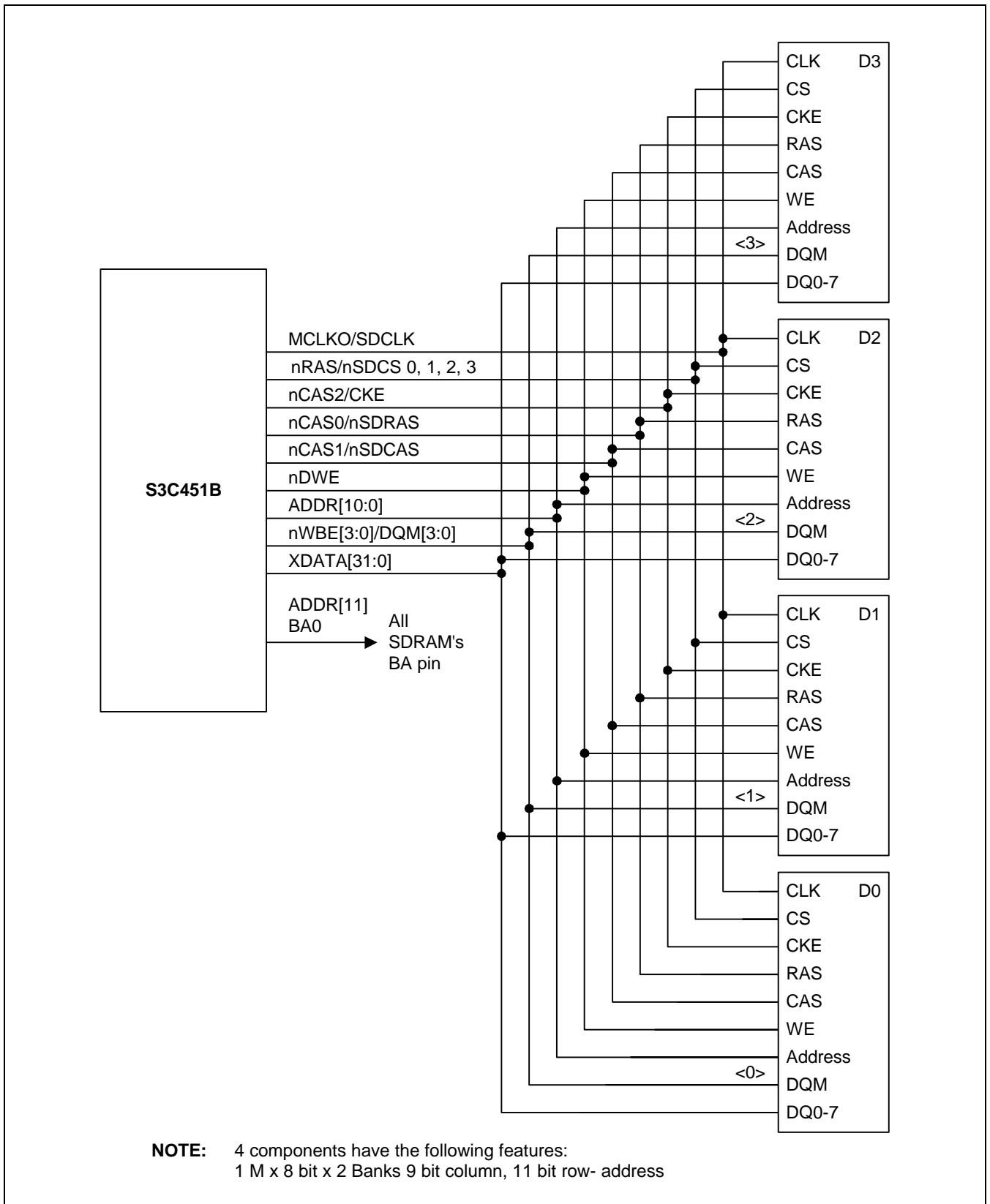

Figure 4-36. SDRAM Application Example

**DRAM REFRESH AND EXTERNAL I/O CONTROL REGISTER**

The S3C4510B DRAM interface supports the CAS-before-RAS (CBR) refresh mode for EDO/FP DRAM and auto-refresh for SDRAM. Settings in the DRAM refresh and external I/O control register, REFEXTCON, control DRAM refresh mode, refresh timings, and refresh intervals. REFEXTCON also contains the 10-bit base pointer value for the external I/O bank 0.

**NOTE**

Whenever the S3C4510B CPU writes one of system manager registers, the validity of special register field (that is, the VSF bit) is automatically cleared and the external bus is disabled. To reactivate external bus, you must set the VSF bit to "1" using a STMIA instruction. It is recommended that programmers always use STMIA instructions to write the 10 system manager special registers. The instruction used to set the VSF bit should always be the last instruction in the register write sequence.

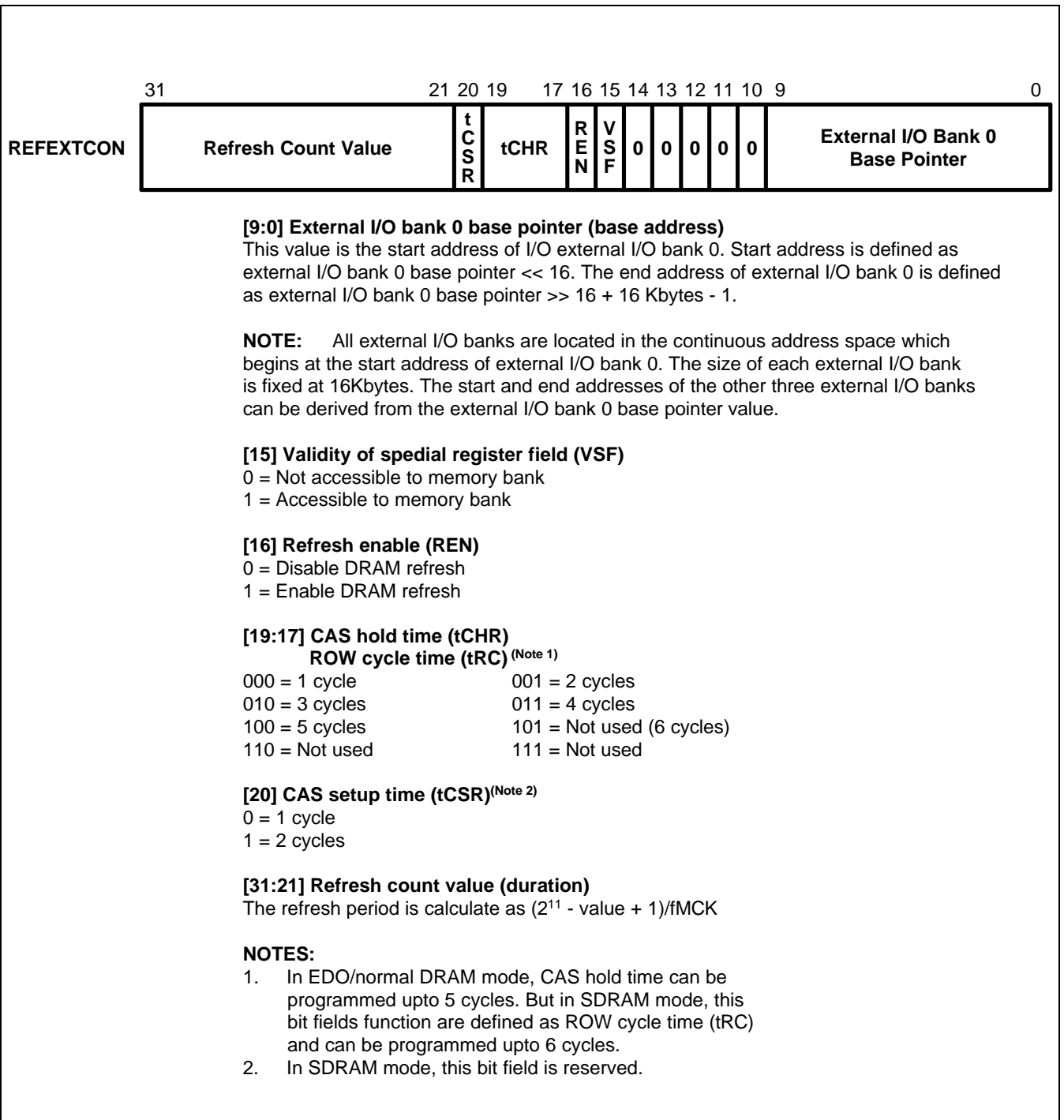

Figure 4-37. DRAM Refresh and External I/O Control Register (REFEXTCON)

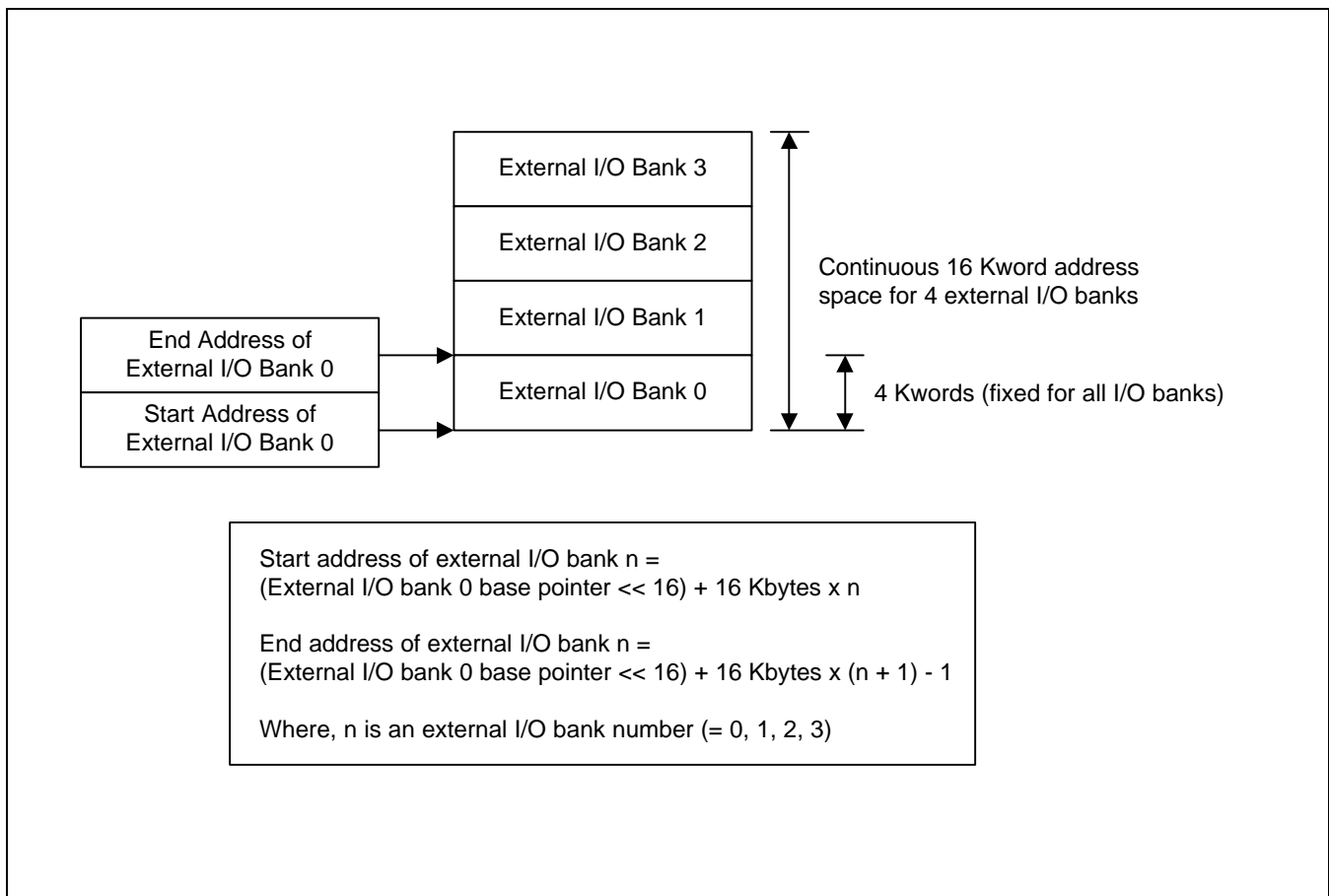

Figure 4-38. External I/O Bank Address Map

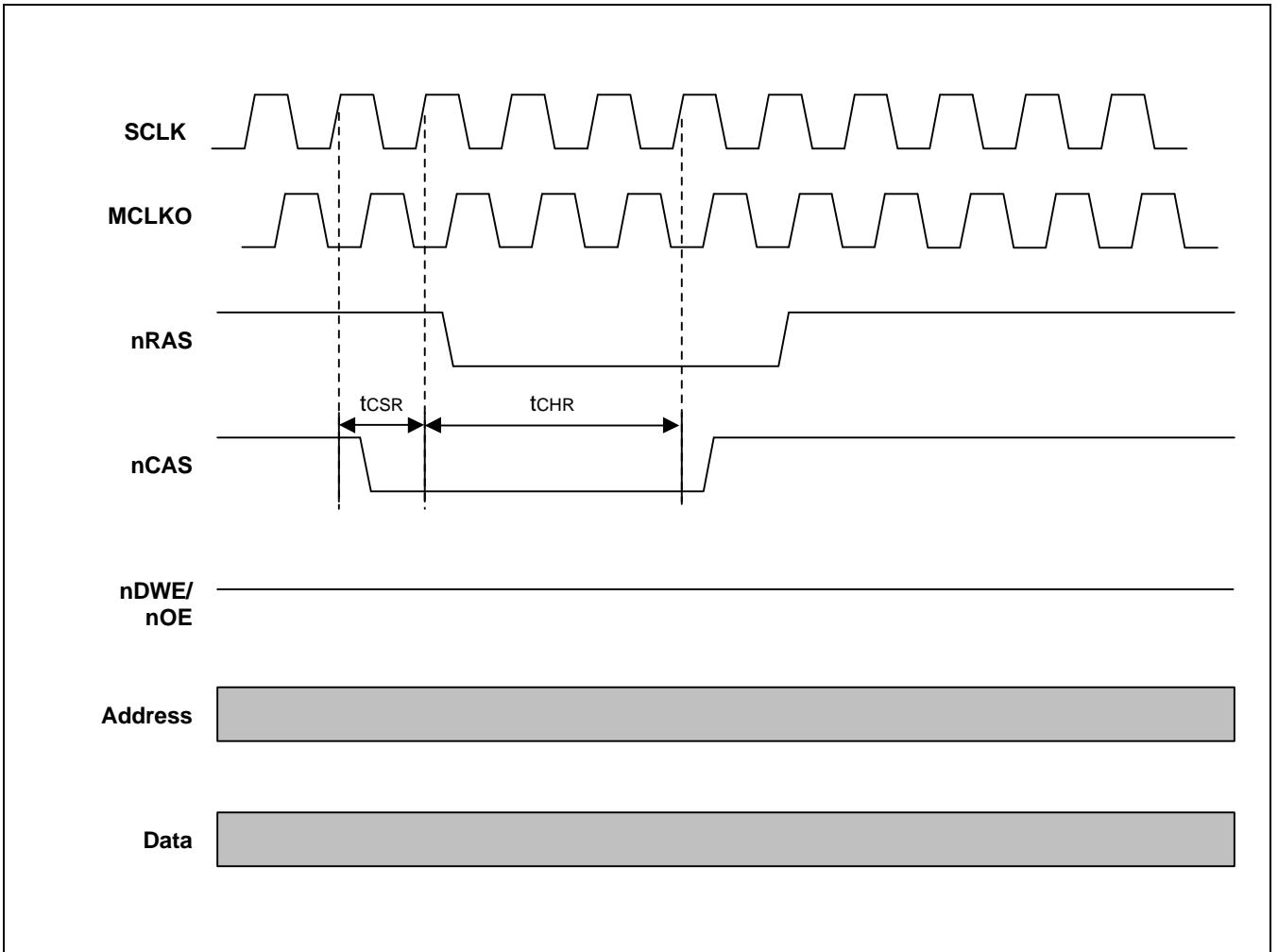

Figure 4-39. EDO/FP DRAM Refresh Timing

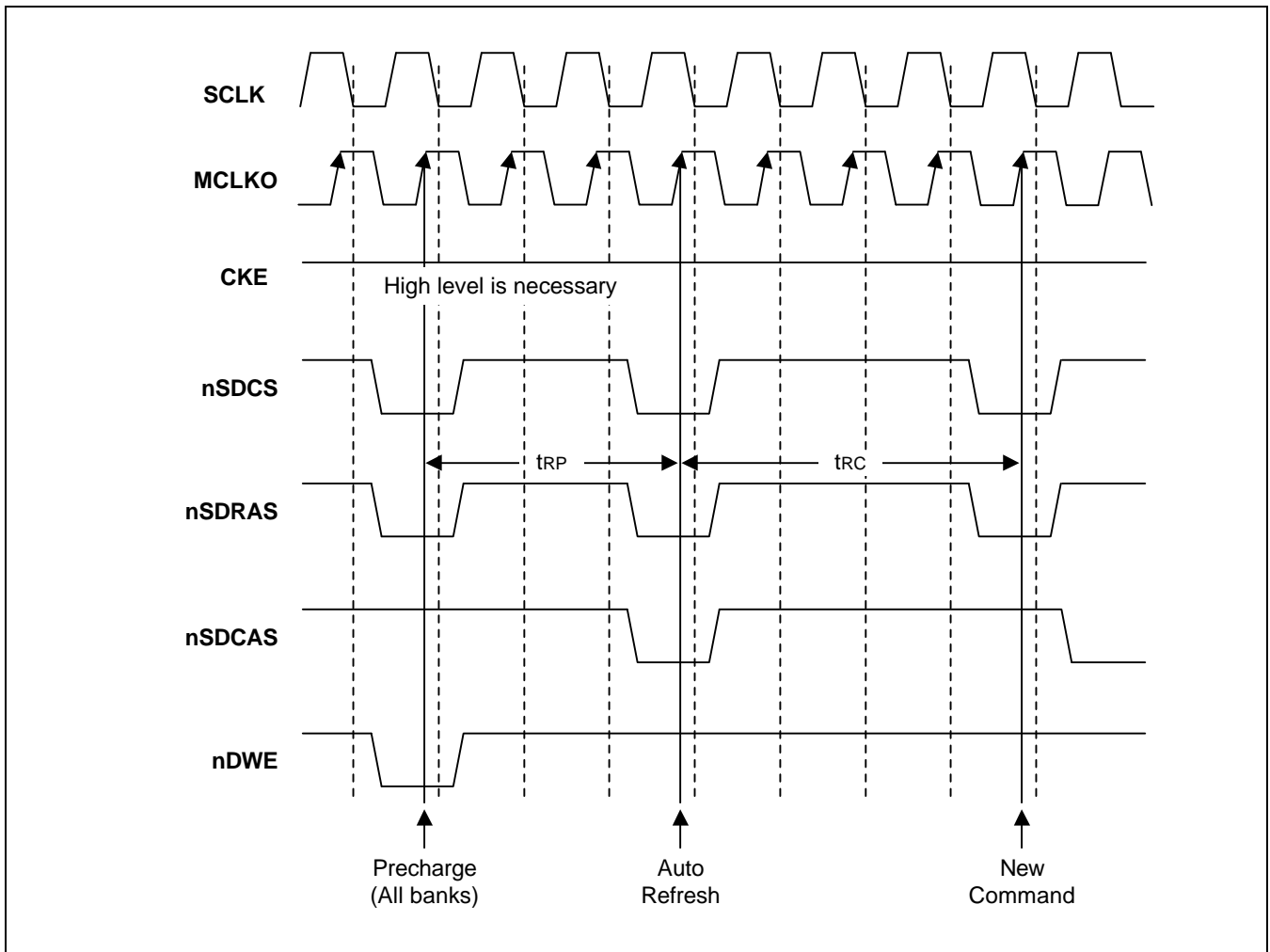

Figure 4-40. Auto Refresh Cycle of SDRAM

**NOTE**

At auto-refresh cycle, DRAM bank0's  $t_{RP}$  bit field is used as RAS pre-charge time parameter.

# 5

## UNIFIED INSTRUCTION/DATA CACHE

### OVERVIEW

The S3C4510B CPU has a unified internal 8K byte instruction/data cache. Using cache control register settings, you can use part or all of this cache as internal SRAM. To raise the cache hit ratio, the cache is configured using two-way, set-associative addressing. The replacement algorithm is pseudo-LRU (Least Recently Used).

The cache line size is four words (16 bytes). When a miss occurs, four words must be fetched consecutively from external memory. Typically, RISC processors take advantage of unified instruction/data caches to improve performance. Without an instruction cache, bottlenecks that occur during instruction fetches from external memory may seriously degrade performance.

### CACHE CONFIGURATION

The S3C4510B's 4K byte, two-way set-associative instruction/data cache uses a 15-bit tag address for each set. The CS bits (a 2-bit value) in tag memory stores information for cache replacement. When a reset occurs, the CS value is "00", indicating that the contents of cache set 0 and cache set 1 are invalid. When the first cache fill operation occurs while exiting from the reset operation, the CS value becomes "01" at the specified line to indicate that only set 0 is valid. When the subsequent cache fill occurs, the CS value becomes "11" at the specified line, indicating that the contents of both set 0 and set 1 are valid.

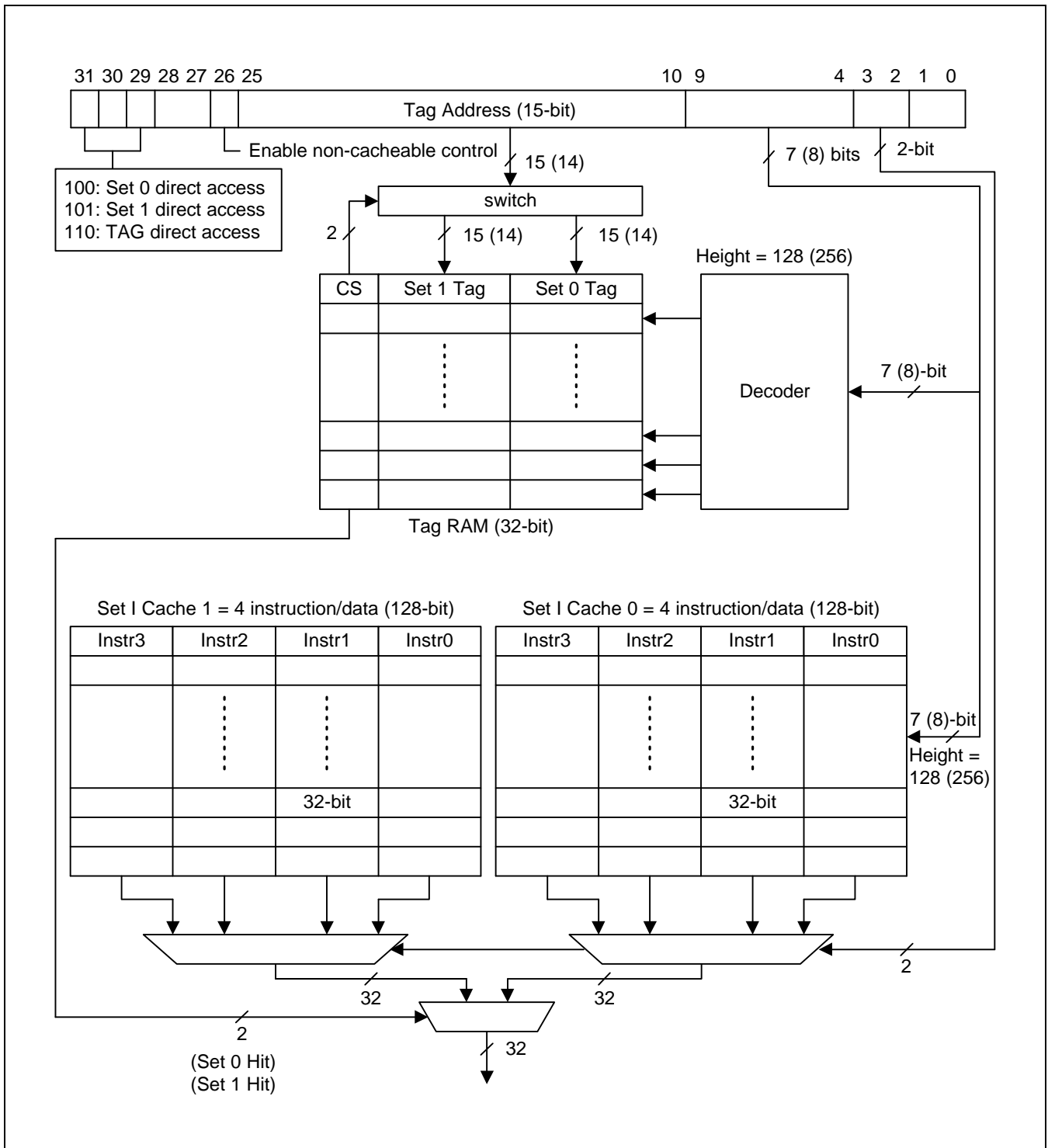

Figure 5-1. Memory Configuration for 4-Kbyte (or 8-Kbyte) Cache



**CACHE REPLACE OPERATIONS**

When the contents of two sets are valid and when the content of the cache must be replaced due to a cache miss, the CS value becomes "10" at specified line. This indicates that the content of set 0 (S0) was replaced. When CS is "10" and when another replacement is required due to a cache miss, the content of set 1 (S1) is replaced by changing the CS value to "01".

To summarise, at its normal steady state, the CS value is changed from "01" or "10" to "10" or "01". This modification provides the information necessary to implement a 2-bit pseudo-LRU (Least Recently Used) cache replacement policy.

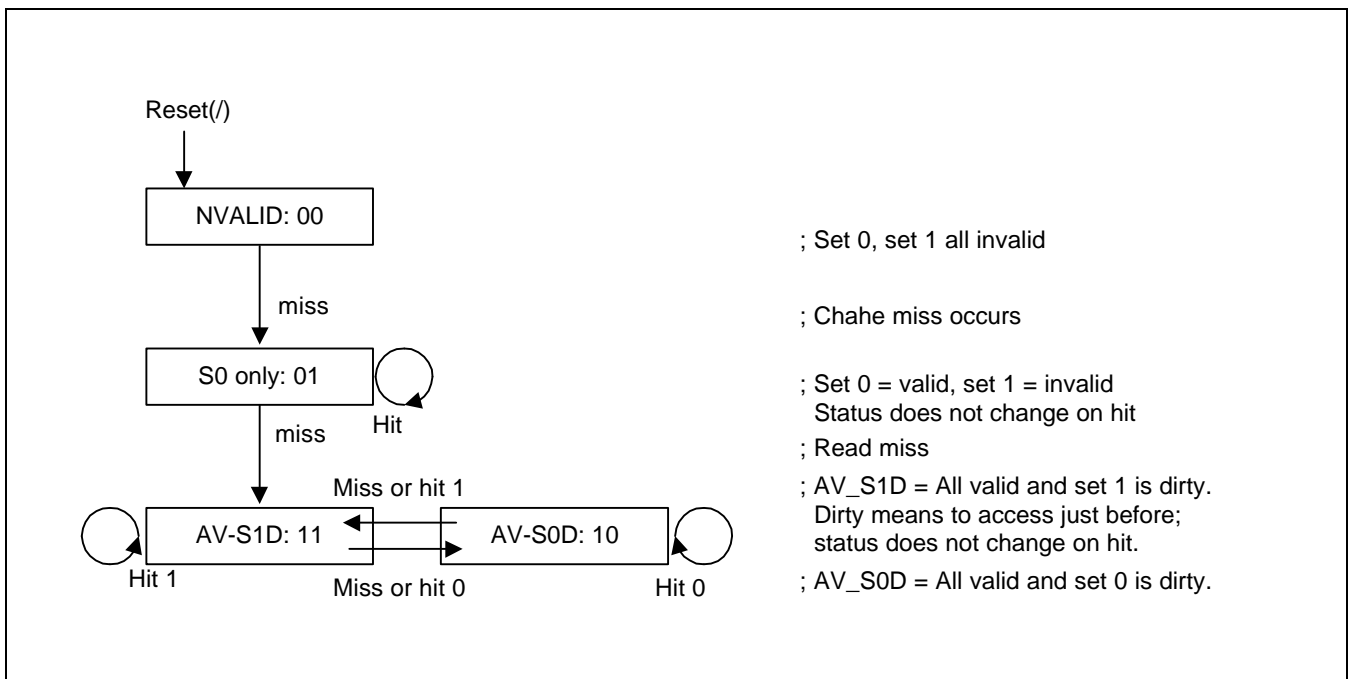

**Figure 5-2. Cache Replace Algorithm State Diagram**

**CACHE DISABLE/ENABLE**

To disable the cache disable entirely following a system reset, you must set SYSCFG[1] to "0". By setting the cache mode bits, SYSCFG[5:4], you can specify a cache size of 0, 4, or 8K bytes. If you do not need the entire 8-Kbyte area for cache, you can use the remaining area as normal internal SRAM. The start address of the internal SRAM area is defined by writing an appropriate value to SYSCFG[15:6].

**CACHE FLUSH OPERATION**

To flush cache lines, you must write a zero to Tag memory bits 31 and 30, respectively.

The 4-Kbyte set 0 RAM area, 4-Kbyte set 1 RAM area, and the 1-Kbyte Tag RAM area (total 256 words) can be accessed from locations 0x10000000H, 0x10800000H, and 0x11000000H, respectively. You can do this independently of the current cache mode bit and cache enable bit settings.

Tag RAM is normally cleared by hardware following a power-on reset. However, if you change the cache or memory bank configuration when the cache is being enabled, you will have to clear the Tag RAM area using application software.

**NON-CACHEABLE AREA CONTROL BIT**

Although the cache affects the entire system memory, it is sometimes necessary to define non-cacheable areas when the consistency of data stored in memory and the cache must be ensured. To support this, the S3C4510B provides a non-cacheable area control bit in the address field, ADDR[26].

If ADDR[26] in the ROM/SRAM, flash memory, DRAM, or external I/O bank's access address is "0", then the accessed data is cacheable. If the ADDR[26] value is "1", the accessed data is non-cacheable.

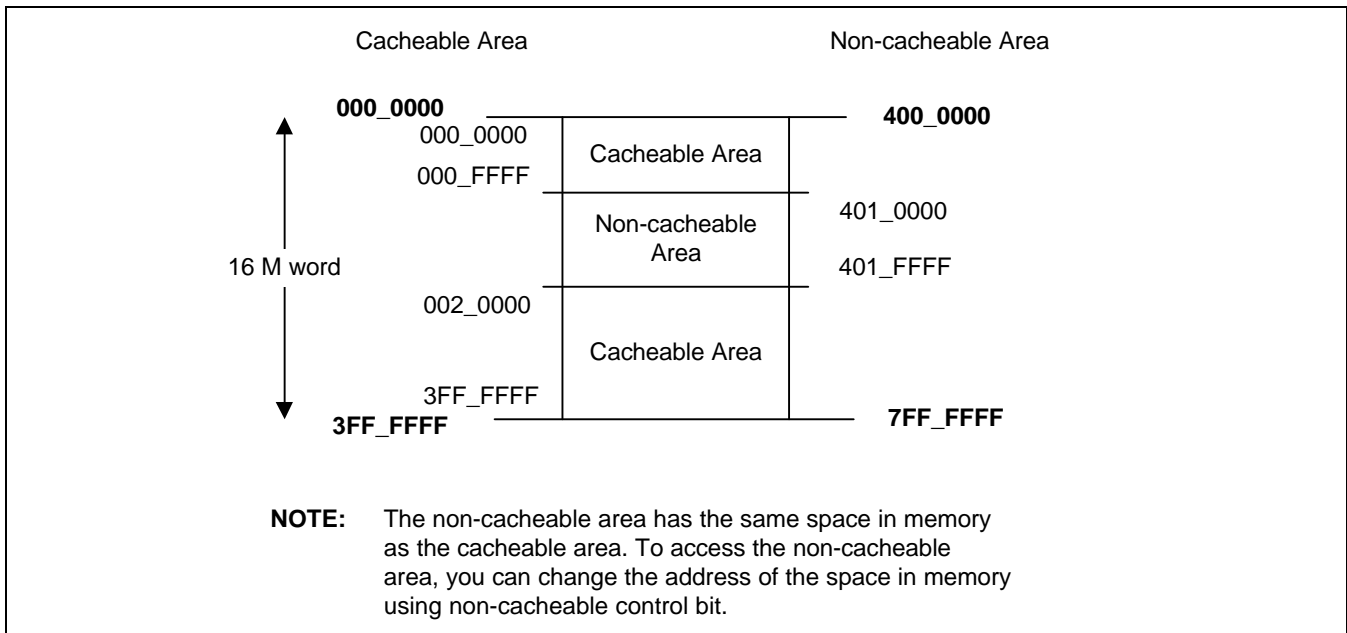

**Figure 5-3. Non-Cacheable Area Control**

**NOTE**

A SWAP command must be used within a non-cacheable area.

# 6 I<sup>2</sup>C BUS CONTROLLER

## OVERVIEW

The S3C4510B's internal IC bus (I<sup>2</sup>C-bus) controller has the following important features:

- It requires only two bus lines, a serial data line (SDA) and a serial clock line (SCL). When the I<sup>2</sup>C-bus is free, both lines are High level.
- Each device that is connected to the bus is software-addressable by a single master using a unique address. slave relationships on the bus are constant. The bus master can be either a master-transmitter or a master-receiver. The I<sup>2</sup>C bus controller supports only single master mode.
- It supports 8-bit, bi-directional, serial data transfers.
- The number of ICs that you can connect to the same I<sup>2</sup>C-bus is limited only by the maximum bus capacitance of 400 pF.

Figure 6-1 shows a block diagram of the S3C4510B I<sup>2</sup>C-bus controller

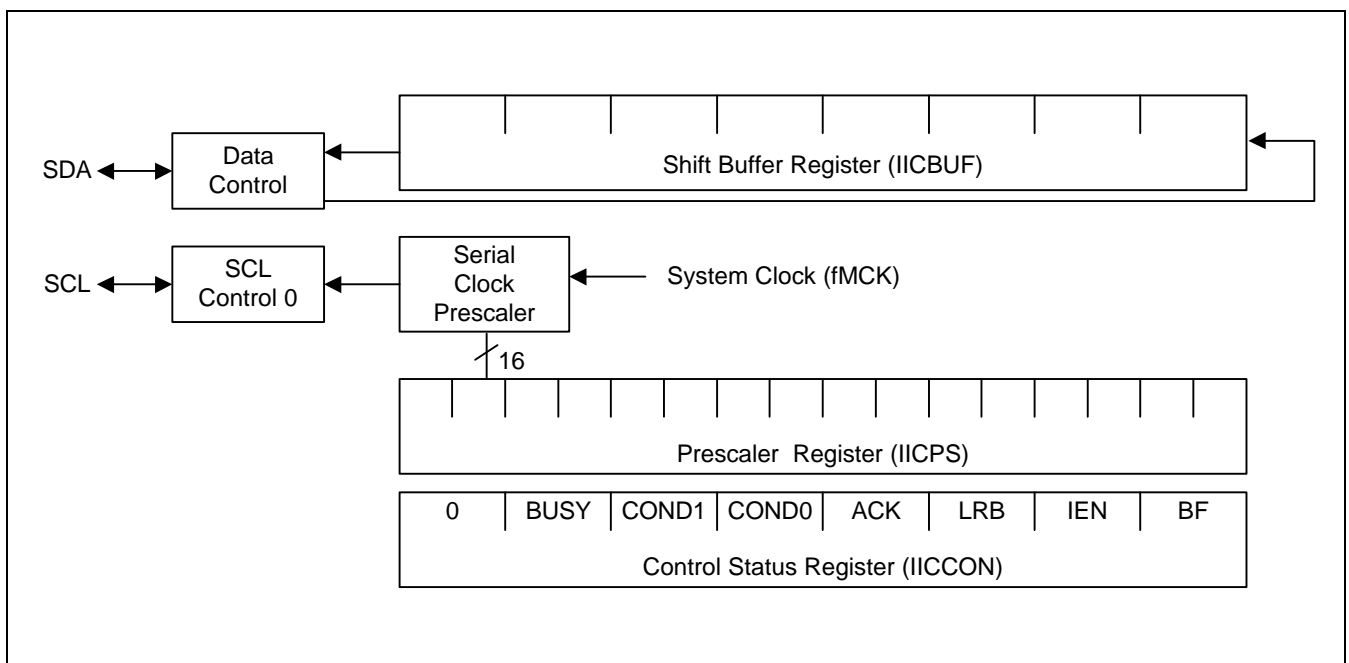

Figure 6-1. I<sup>2</sup>C BUS Block Diagram

## FUNCTIONAL DESCRIPTION

The S3C4510B I<sup>2</sup>C bus controller is the master of the serial I<sup>2</sup>C-bus. Using a prescaler register, you can program the serial clock frequency that is supplied to the I<sup>2</sup>C bus controller. The serial clock frequency is calculated as follows:

$$\text{MCLK} / (16 \times (\text{prescaler register value} + 1) + 3)$$

To initialize the serial I<sup>2</sup>C-bus, the programmer sends a start code by writing "01" to bits [5:4] of the control status register, IICCON. The bus controller then sends the 7-bit slave address and a read/write control bit through shift buffer register. The receiver sends an acknowledge by pulling the SDA line from high to low during a master SCL pulse.

To continue the data write operation, you must set the BF bit in the control status register and then write the data to the shift buffer register. Whenever the shift buffer register is read or written, the BF bit is cleared automatically. For the consecutive read/write operations, you must set the ACK bit in the control status register.

For read operations, you can read the data after you have set the BF bit in the control status register. To signal the end of the read operation, you can reset the ACK bit to inform the receiver/transmitter when the last byte is to be written/read.

Following a read/write operation, you set IICCON[5:4] to "10" to generate a stop code. If you want to complete another data transfer before issuing the Stop code, you can send the start code using the repeat start command (with IICCON[5:4] = "11"). When the slave address and read/write control bit have been sent, and when the receive acknowledge has been issued to control SCL timing, the data transfer is initiated.

## I<sup>2</sup>C-BUS CONCEPTS

### Basic Operation

The I<sup>2</sup>C-bus has two wires, a serial data line (SDL) and a serial clock line (SCL), to carry information between the ICs connected to the bus. Each IC is recognized by a unique address and can operate as either a transmitter or receiver, depending on the function of the specific ICs.

The I<sup>2</sup>C-bus is a multi-master bus. This means that more than one IC which is capable of controlling the bus can be connected to it. data transfers proceed as follows:

Case 1: A master IC wants to send data to another IC (slave):

1. Master addresses slave
2. Master sends data to the slave (master is transmitter, slave is receiver)
3. Master terminates the data transfer

Case 2: A master IC wants to receive information from another IC (slave):

1. Master addresses slave
2. Master receives data from the slave (master is receiver, slave is transmitter)
3. Master terminates the data transfer

Even in case 2, the master IC must generate the timing signals and terminate the data transfer.

If two or more masters try to put information simultaneously onto the bus, the first master to issue a "1" when the other issues a "0" will lose the bus arbitration. The clock signals used for arbitration are a synchronized combination of the clocks generated by the bus masters using the wired-AND connection to the SCL line.

The master IC is always responsible for generating the clock signals on the I<sup>2</sup>C-bus. Bus clock signals from a master can only be altered by 1) a slow slave IC which "stretches" the signal by temporarily holding the clock line Low, or 2) by another master IC during arbitration.

### General Characteristics

Both SDA and SCL are bi-directional lines which are connected to a positive supply voltage through a pull-up resistor.

When the I<sup>2</sup>C-bus is free, the SDA and SCL lines are both high level. The output stages of I<sup>2</sup>C interfaces connected to the bus have an open-drain or open-collector to perform the wired-AND function. Data on the I<sup>2</sup>C-bus can be transferred at a rate up to 100 Kbits/s. The number of interfaces that can be connected to the bus is solely dependent on the limiting bus capacitance of 400 pF.

### Bit Transfers

Due to the variety of different ICs (CMOS, NMOS, and I<sup>2</sup>L, for example) which can be connected to the I<sup>2</sup>C-bus, the levels of logic zero (low) and logic one (high) are not fixed and depend on the associated level of  $V_{DD}$ . One clock pulse is generated for each data bit that is transferred.

### Data Validity

The data on the SDA line must be stable during the high period of the clock. The high or low state of the data line can only change when clock signal on the SCL line is low.

### Start and Stop Conditions

Start and stop conditions are always generated by the master. The bus is considered to be busy after the start condition is generated. The bus is considered to be free again when a brief time interval has elapsed following the Stop condition.

- Start condition: a High-to-Low transition of the SDA line while SCL is high.
- Stop condition: a Low-to-High transition of the SDA line while SCL is high.

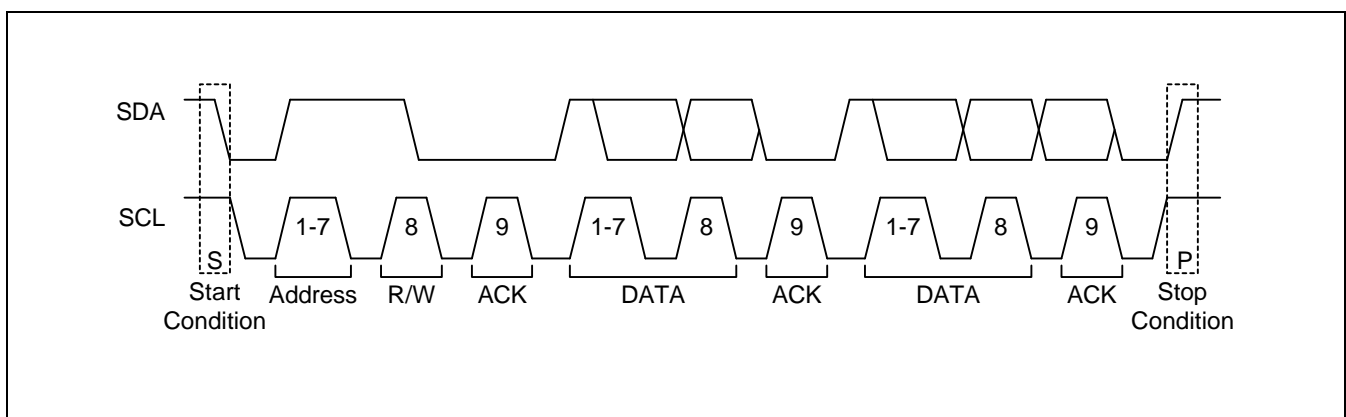

Figure 6-2. Start and Stop Conditions

## DATA TRANSFER OPERATIONS

### Data Byte Format

Every data byte that is put on the SDA line must be 8 bits long. The number of bytes that can be transmitted per transfer is unlimited. Each byte must be followed by an acknowledge bit. Data is transferred MSB-first.

If the receiver cannot receive another complete byte of data until it has performed some other function (such as servicing an internal interrupt), it can hold the clock line SCL Low to force the transmitter into a wait state. The data transfer then continues when the receiver is ready for another byte of data and releases the SCL line.

### Acknowledge Procedure

Data transfer with acknowledge is obligatory. The acknowledge-related clock pulses must be generated by the bus master. The transmitter releases the SDA line (High) during the acknowledge clock pulse.

The receiver must pull down the SDA line during the acknowledge pulse so that it remains stable low during the High period of this clock pulse.

Usually, a receiver which has been addressed is obliged to generate an acknowledge after each byte is received. When a slave receiver does not acknowledge from the slave address, the slave must leave the data line high. The master can then generate a stop condition to abort the transfer.

If a slave receiver acknowledges the slave address, but later in the transfer cannot receive any more data bytes, the master must again abort the transfer. This is indicated by the slave not generating the acknowledge on the first byte to follow. The slave leaves the data line high and the master generates the stop condition.

If a master receiver is involved in a transfer, it must signal the end of data to the slave transmitter by not generating an acknowledge on the last byte that was clocked out of the slave. The slave transmitter must then release the data line to let the master generate the stop condition.

### Data Transfer Format

Data transfers uses the format shown in Figure 6-3. After the start condition has been generated, a 7-bit slave address is sent. The eighth bit is a data direction bit (R/W). A "0" direction bit indicates a transmission (Write) and a "1" indicates a request for data (Read).

A data transfer is always terminated by a stop condition which is generated by the master. However, if a master still wishes to communicate on the bus, it can generate another start condition and address another slave without first generating a stop condition. This feature supports the use of various combinations of read/write formats for data transfers.

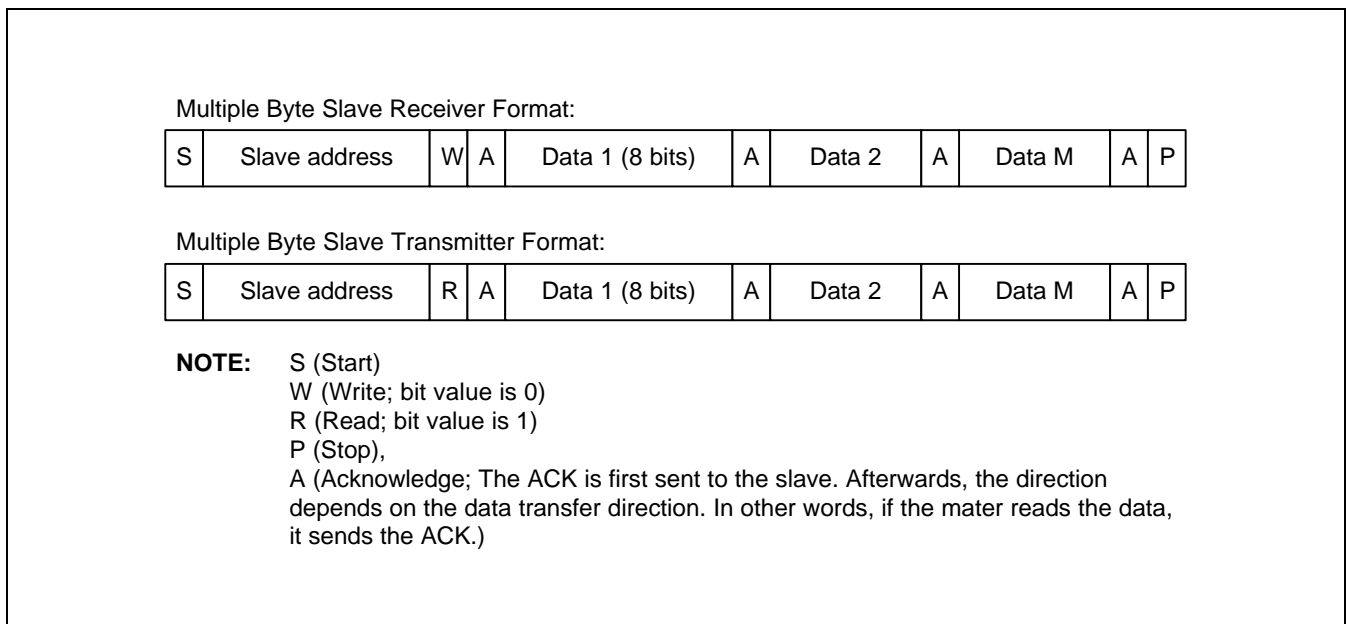

Figure 6-3. Data Transfer Format



## I<sup>2</sup>C-Bus Addressing

The addressing procedure for the I<sup>2</sup>C-bus is such that the first byte after the start condition determines which slave the master will select. Usually, this first byte immediately follows the start procedure.

An exception is the "general call" address which can address all ICs simultaneously. When this address is used, all ICs should, in theory, respond with an acknowledge. However, ICs can also be made to ignore this address. The second byte of the general call address then defines the action to be taken.

### Definition of Bits in the First Data Byte

The first seven bits of the first data byte make up the slave address. The eighth bit is the LSB, or direction bit, which determines the direction (R/W) of the message.

When an address is sent, each IC on the bus compares the first 7 bits received following start condition with its own address. If the addresses match, the IC considers itself addressed by the master as a slave receiver or a slave transmitter.

### General Call Address

The general call address can be used to address every IC that connected to the I<sup>2</sup>C-bus. However, if an IC does not need any of the data supplied within the general call structure, it can ignore this address by not acknowledging it.

If an IC does require data from a general call address, it can then acknowledge this address and behave as a slave receiver. The second and following bytes will be acknowledged by every slave receiver capable of handling this data. A slave which cannot process one of these bytes must ignore it by not acknowledging. The meaning of the general call address is always specified in the second byte.

### Start Byte

Every data transfer is preceded by a start procedure:

- A start condition, S
- A start byte, "00000001"
- An acknowledge (ACK) clock pulse, and
- A repeated start condition, Sr

After the start condition (S) has been transmitted by a master which requires bus access, the start byte ("00000001") is transmitted. Another IC can therefore sample the SDA line at a low sampling rate until one of the seven zeros in the start byte is detected. After it detects this low level on the SDA line, the IC can switch to a higher sampling rate to find the repeated start condition (Sr) which is then used for synchronization. (A hardware receiver will reset upon receipt of the repeated start condition (Sr) and will therefore ignore the start byte.)

An acknowledge-related clock pulse is generated after the start byte. This is done only to conform with the byte handling format used on the bus. No IC is allowed to acknowledge the start byte.

## I<sup>2</sup>C BUS SPECIAL REGISTERS

The I<sup>2</sup>C-bus controller has three special registers: a control status register (IICCON), a prescaler register (IICPS), and a shift buffer register (IICBUF).

### Control Status Register (IICCON)

The control status register for the I<sup>2</sup>C-bus, IICCON, is described in Table 6-2.

**Table 6-1. Control Status Register (IICCON)**

Register	Offset Address	R/W	Description	Rest Value
IICCON	0xf000	R/W	Control status register	0x00000000

**Table 6-2. IICCON Register Description**

Bit Number	Bit Name	Description
[0]	Buffer flag (BF)	The BF bit is set when the buffer is empty in transmit mode or when the buffer is full in receive mode. To clear the buffer, you write a "0" to this bit. The BF bit is cleared automatically whenever the IICBUF register is written or read. If you set BF bit to one, the I <sup>2</sup> C -bus is stopped. To activate I <sup>2</sup> C-bus, you should clear the BF bit to zero.
[1]	Interrupt enable (IEN)	Setting the interrupt enable bit to "1" enables the I <sup>2</sup> C-bus interrupt.
[2]	Last received bit (LRB)	The LRB bit is read only. It holds the value of the last received bit over the I <sup>2</sup> C-bus. Normally, this bit will be the value of the slave acknowledgement. To check for slave acknowledgement, you test the LRB.
[3]	Acknowledge enable (ACK)	The ACK bit is normally set to "1". This causes the I <sup>2</sup> C-bus controller to send an acknowledge automatically after each byte. This bit must be "0" when the I <sup>2</sup> C-bus controller is operating in receiver mode and requires no further data to be received from the slave transmitter. This causes a negative acknowledge on the I <sup>2</sup> C-bus, which halts further reception from the slave device.
[5:4]	COND1, COND0	These bits control the generation of the start, Stop, and repeat Start conditions: "00" = no effect, "01" = start, "10" = stop, and "11" = repeat start.
[6]	Bus busy (BUSY)	This bit is a read-only flag that indicates when the I <sup>2</sup> C-bus is in use. A "1" indicates that the bus is busy. This bit is set or cleared by a start or stop condition, respectively.
[7]	Reset	If "1" is written to the reset bit, the I <sup>2</sup> C-bus controller is reset to its initial state.
[31:8]	Reserved	Not applicable.

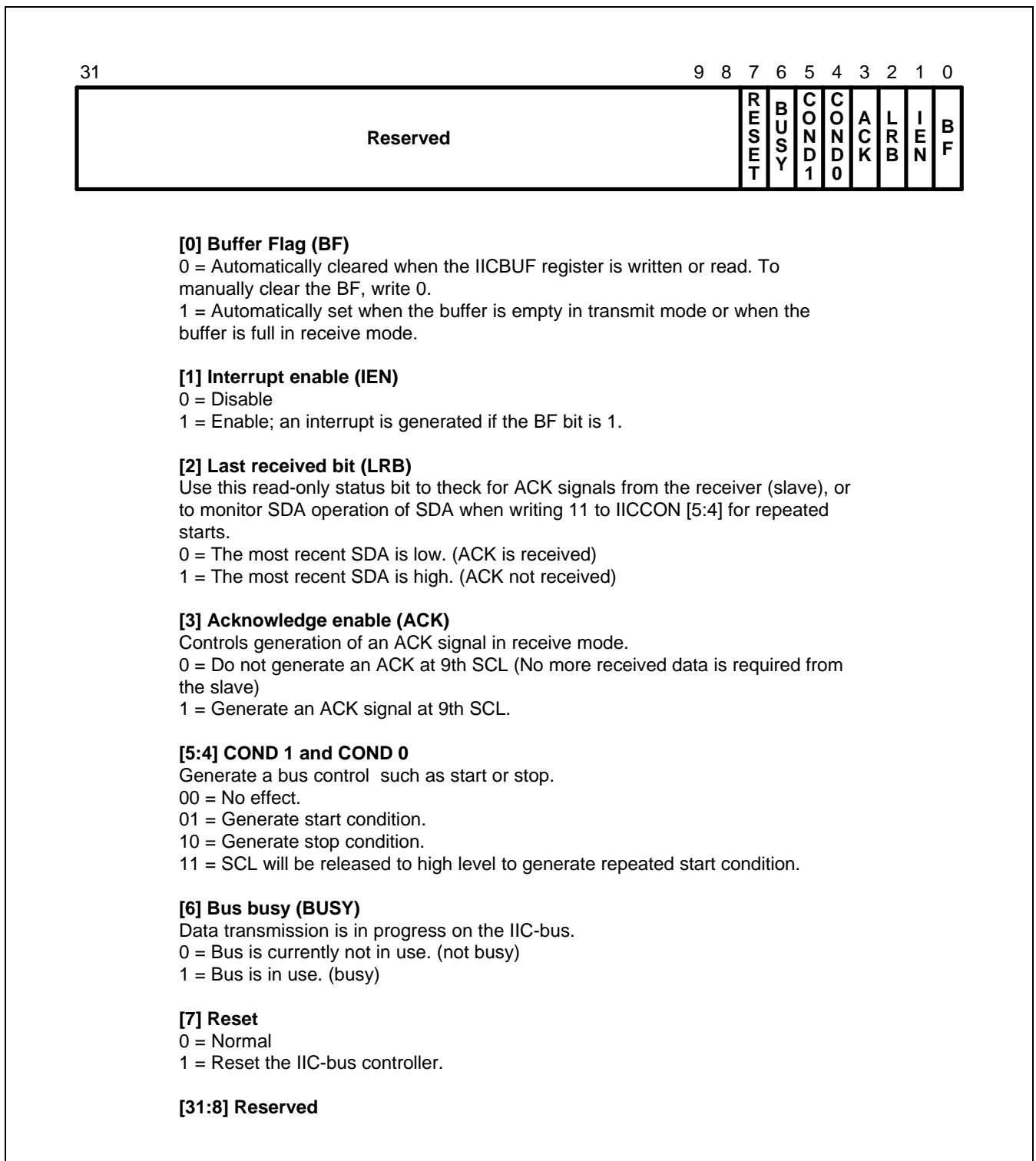
Figure 6-4. I<sup>2</sup>C Control Status Register

**Shift Buffer Register (IICBUF)**

The shift buffer register for the I<sup>2</sup>C-bus described in Table 6-4.

**Table 6-3. IICBUF Register**

Register	Offset Address	R/W	Description	Rest Value
IICBUF	0xf004	R/W	Shift buffer register	Undefined

**Table 6-4. IICBUF Register Description**

Bit Number	Bit Name	Description
[7:0]	Data	This data field acts as serial shift register and read buffer for interfacing to the I <sup>2</sup> C-bus. All read and write operations to/from the I <sup>2</sup> C-bus are done via this register. The IICBUF register is a combination of a shift register and a data buffer. 8-bit parallel data is always written to the shift register, and read from the data buffer. I <sup>2</sup> C-bus data is always shifted in or out of the shift register.
[31:8]	Reserved	Not applicable.

**Prescaler Register (IICPS)**

The prescaler register for the I<sup>2</sup>C-bus is described in Table 6-6.

**Table 6-5. IICPS Register**

Register	Offset Address	R/W	Description	Rest Value
IICPS	0xf008	R/W	Prescaler register	0x00000000

**Table 6-6. IICPS Register Description**

Bit Number	Bit Name	Description
[15:0]	Prescaler value	This prescaler value is used to generate the serial I <sup>2</sup> C-bus clock. The system clock is divided by $(16 \times (\text{prescaler value} + 1) + 3)$ to make the serial I <sup>2</sup> C clock. If the prescaler value is zero, the system clock is when divided by 19 to make the serial I <sup>2</sup> C clock.
[31:16]	Reserved	Not applicable.

**Prescaler Counter Register (IICCNT)**

The prescaler counter register for the I<sup>2</sup>C-bus is described in Table 6-8.

**Table 6-7. IICCNT Register**

Register	Offset Address	R/W	Description	Rest Value
IICCNT	0xf00c	R/W	Prescaler counter register	0x00000000

**Table 6-8. IICCNT Register Description**

Bit Number	Bit Name	Description
[15:0]	Counter value	This 16-bit value is the value of the prescaler counter. It is read (in test mode only) to check the counter's current value.
[31:16]	Reserved	Not applicable.

## NOTES

# 7

## ETHERNET CONTROLLER

### OVERVIEW

The S3C4510B has an ethernet controller which operates at either 100-Mbits or 10-Mbits per second in half-duplex or full-duplex mode. In half-duplex mode, the controller supports the IEEE 802.3 carrier sense multiple access with collision detection (CSMA/CD) protocol. In full-duplex mode, it supports the IEEE 802.3 MAC control layer, including the pause operation for flow control.

The ethernet controller's MAC layer supports both the media independent interface (MII) and the buffered DMA interface (BDI). The MAC layer itself consists of the receive and the transmit blocks, a flow control block, a content addressable memory (CAM) for storing network addresses, and a number of command, status, and error counter registers.

The MII supplies the transmit and receive clocks of 25 MHz for 100-Mbit/s operation or 2.5 MHz at the 10-Mbit/s speed. The MII conforms to the ISO/IEC 802-3 standards for a media-independent layer which separates physical layer issues from the MAC layer.

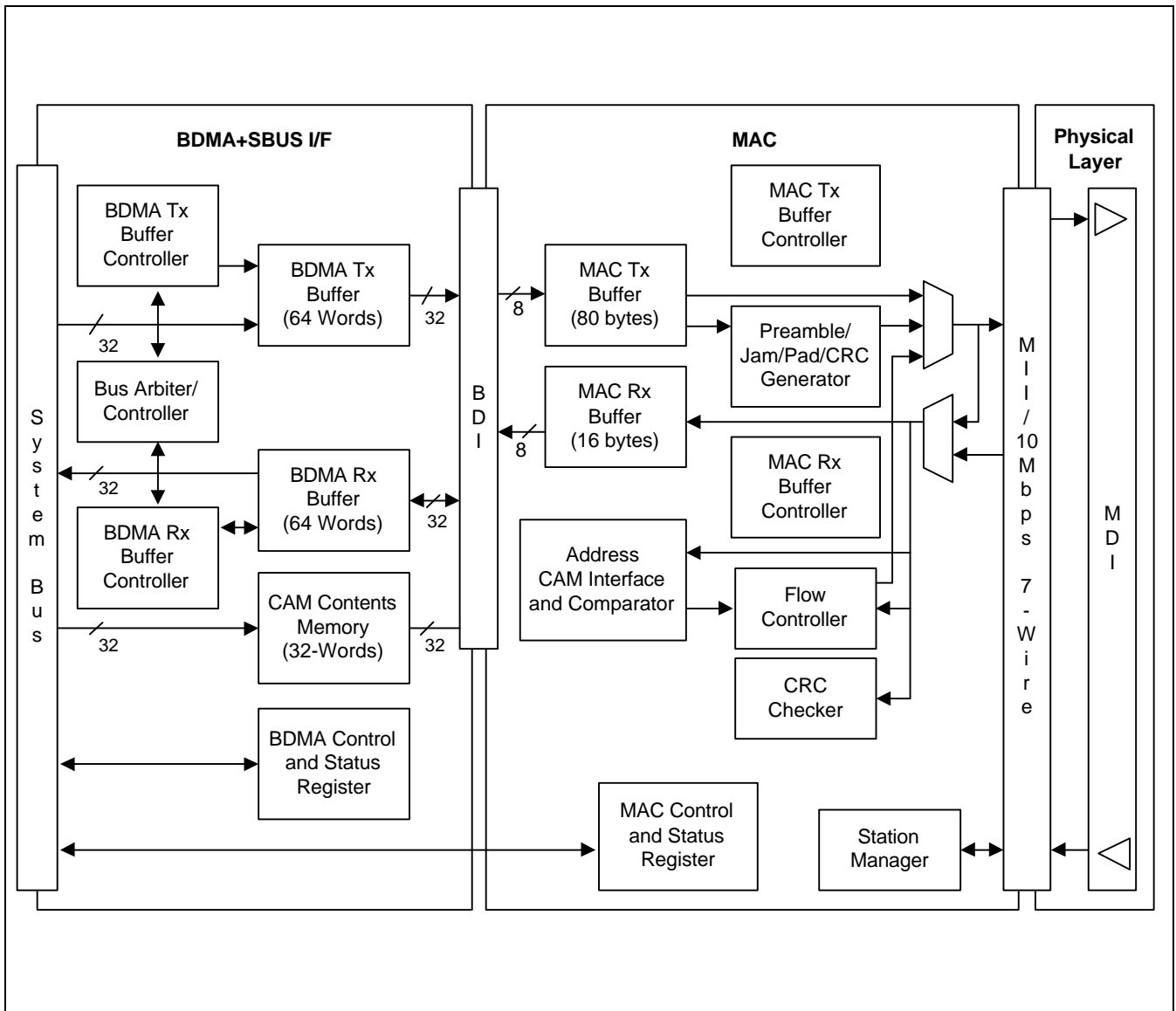

Figure 7-1. Ethernet System Flow Control



## FEATURES AND BENEFITS

The most important features and benefits of the S3C4510B ethernet controller are as follows:

- Cost-effective connection to an external RIC/Ethernet backbone
- Buffered DMA (BDMA) engine using burst mode
- BDMA Tx/Rx buffers (256 bytes/256 bytes)
- MAC Tx/Rx FIFOs (80 bytes/16 bytes) to support re-transmit after collision without DMA request and to handle DMA latency
- Data alignment logic
- Endian translation
- Support for old and new media (compatible with existing 10-Mbit/s networks)
- 100-Mbit/s or 10-Mbits/s operation to increase price/performance options and to support phased conversions
- Full IEEE 802.3 compatibility for existing applications
- Media Independent interface (MII) or 7-wire interface
- Station management (STA) signaling for external physical layer configuration and link negotiation
- On-chip CAM (21 addresses)
- Full-duplex mode for doubled bandwidth
- Pause operation hardware support for full-duplex flow control
- Long packet mode for specialized environments
- Short packet mode for fast testing
- PAD generation for ease of processing and reduced processing time

## MAC FUNCTION BLOCKS

The major function blocks of the ethernet controller's MAC layer are described in Table 7-1 and Figure 7-1.

**Table 7-1. MAC Function Block Descriptions**

Function Block	Description
Media Independent Interface (MII)	The interface between the physical layer and the transmit and receive blocks.
Transmit block	Moves the outgoing data from the transmit buffer to the MII. The transmit block includes circuits for generating the CRC, checking parity, and generating preamble or jam. The transmit block also has timers for back-off after collision and for the interframe gap the follows a transmission.
Receive block	Accepts incoming data from the MII and stores it in the receive FIFO. The receive block has logic for computing and checking the CRC value, generating parity for data from the MII, and checking minimum and maximum packet lengths. The receive block also has a content addressable memory (CAM) block which provides for address lookup, and for acceptance or rejection for packets based on their destination address.
Flow control block	Recognizes MAC control packets and supports the pause operation for full-duplex links. The flow control block also supports generation of pause packets, and provides timers and counters for pause control.
MAC control (command) and status registers	Controls programmable options, including the enabling or disabling of signals which notify the system when conditions occur. The status registers hold information for error handling software, and the error counters accumulate statistical information for network management software.
Loop-back circuit	Provides for MAC-layer testing in isolation from the MII and physical layer.

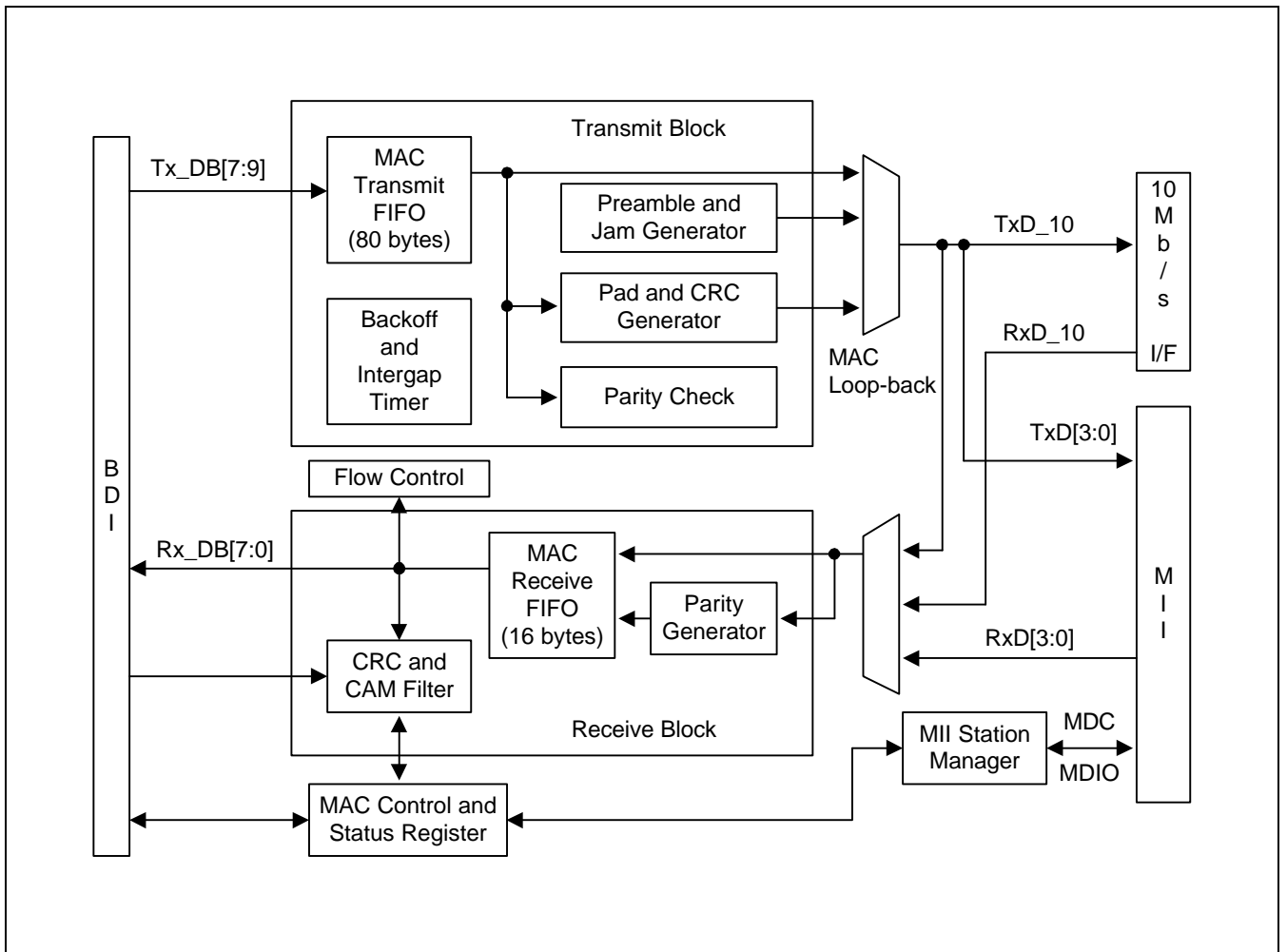

Figure 7-2. MAC Layer Flow Control Function Blocks

**MEDIA INDEPENDENT INTERFACE (MII)**

Transmit and receive blocks both operate using the MII, which was developed by the IEEE802.3 task force on 100-Mbit/s ethernet. This interface has the following characteristics:

- Media independence
- Multi-vendor points of interoperability
- Supports connection of MAC layer and physical layer entity (PHY) devices
- Capable of supporting both 100-Mbit/s and 10-Mbit/s data rates
- Data and delimiters are synchronous to clock references
- Provides independent 4-bit wide transmit and receive data paths
- Uses TTL signal levels that are compatible with common digital CMOS ASIC processes
- Supports connection of PHY layer and station management (STA) devices
- Provides a simple management interface
- Capable of driving a limited length of shielded cable

**PHYSICAL LAYER ENTITY (PHY)**

The physical layer entity, or PHY, performs all of the decoding/encoding on incoming and outgoing data. The manner of decoding and encoding (Manchester for 10BASE-T, 4B/5B for 100BASE-X, or 8B/6T for 100BASE-T4) does not affect the MII. The MII provides the raw data it receives, starting with the preamble and ending with the CRC. The MII expects raw data for transmission, also starting with the preamble and ending with the CRC. The MAC layer also generates jam data and transmits it to the PHY.

**BUFFERED DMA INTERFACE (BDI)**

The buffered DMA interface (BDI) supports read and write operations across the system bus. Two eight-bit buses transfer data with optional parity checking. The system interface initiates data transfers. The MAC-layer controller responds with a ready signal to accept data for transmission, or to deliver data which has been received. An end-of-frame signal indicates the boundary between packets.

**THE MAC TRANSMIT BLOCK**

The MAC transmit block is responsible for transmitting data. It complies with the IEEE802.3 standard for carrier sense multiple access with collision detection (CSMA/CD) protocol. The MAC transmit block consists of the following sections:

- Transmit FIFO and controllers
- Preamble and jam generators
- Pad generator
- Parallel CRC generator
- Threshold logic and counters
- Back-off and retransmit timers
- Transmit state machine

Figure 7-3 shows the MAC transmit function blocks in detail.

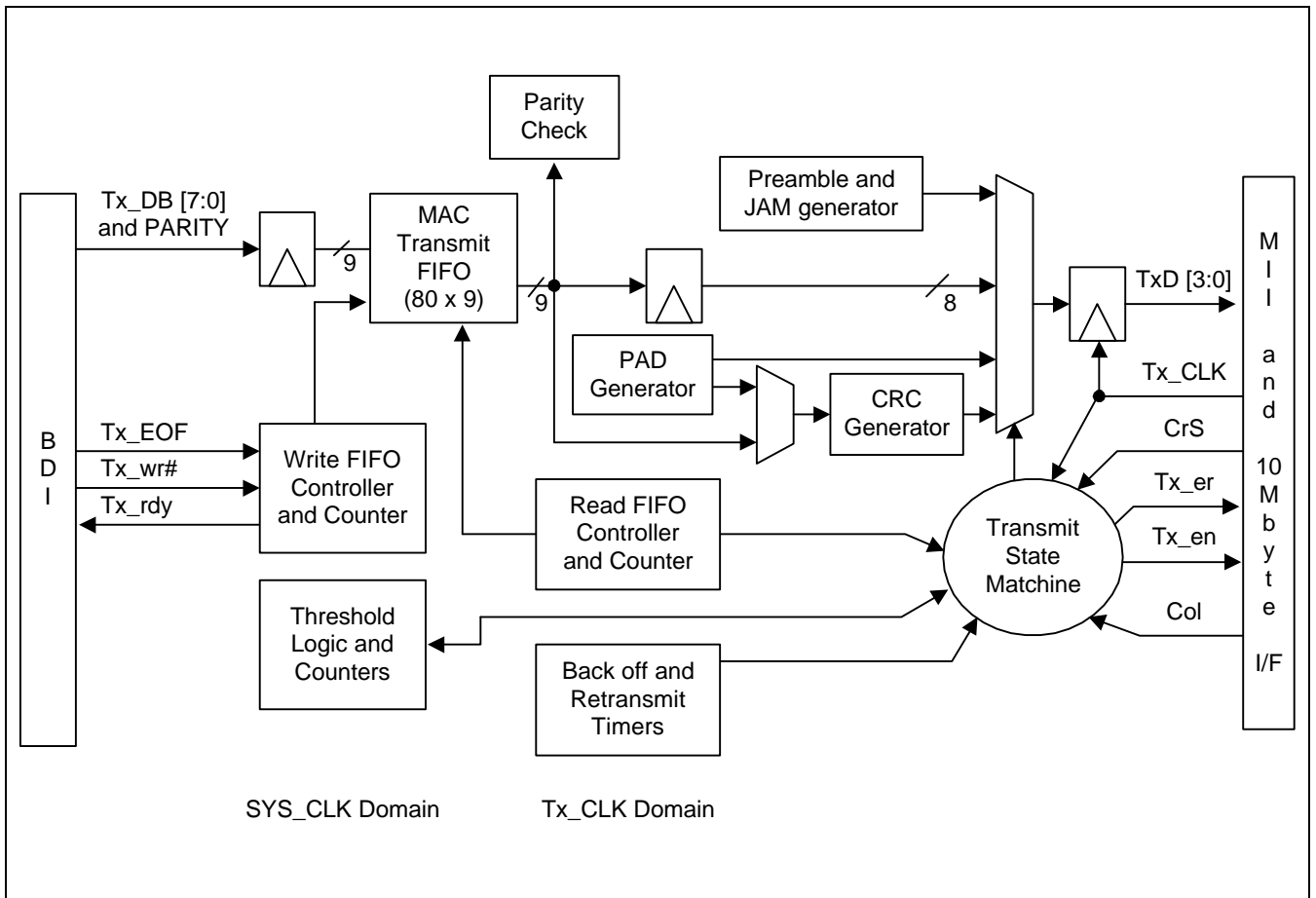

**Figure 7-3. MAC Transmit Function Blocks**

### Transmit FIFO and Read/Write Controllers

The transmit FIFO has an 80-byte depth. An extra bit is associated with each data byte for parity checking. This 80-byte by 9-bit size allows the first 64 bytes of a data packet to be stored and retransmitted, without further system involvement, in case of a collision. If no collision occurs and transmission is underway, the additional 16 bytes handle system latency and avoid FIFO under-run.

When the system interface has set the transmit enable bit in the appropriate control register, the transmit state machine requests data from the BDI. The system controller then fetches data from the system memory.

The FIFO controller stores data in the transmit FIFO until the threshold for transmit data is satisfied. The FIFO controller passes a handshaking signal to the transmit state machine, indicating that sufficient data is in the FIFO to start the transmit operation. If the FIFO is not full, the FIFO controller issues a request to the BDI for more data. The transmit state machine continues transmitting data until it detects the end-of-frame signal, which signals the last byte. It then appends the calculated CRC to the end of the data (unless the CRC truncate bit in the transmit control register is set). The packet transmit bit in the status register is set, generating an interrupt if it is enabled.

The FIFO counters in this block (the Write counter) and the transmit FIFO counter of the transmit state machine (the Read counter) co-ordinate their functions based on each other's count value, although they do have different clock sources.

The FIFO controller stores parity bits with the data in the FIFO. It checks for parity and can halt transmission after reading the data out of the FIFO and sending it for the CRC calculation. If a parity error occurs, the FIFO controller sets an error status bit, generating an interrupt if it is enabled.

### Preamble and Jam Generator

As soon as the transmit enable bit in the control register is set and there are eight bytes of data in the FIFO, the transmit state machine starts the transmission by asserting the Tx\_en signal and transmitting the preamble and the start frame delimiter (SFD). In case there is a collision, it transmits a 32-bit string of "1s" after the preamble as a jam pattern.

### PAD Generator

If a short data packet is transmitted, the MAC will normally generate pad bytes to extend the packet to a minimum of 64 bytes. The pad bytes consist entirely of "0" bits. A control bit is also used to suppress the generation of pad bytes.

### Parallel CRC Generator

The CRC generation of the outgoing data starts from the destination address and continues through the data field. You can suppress CRC generation by setting the appropriate bit in the transmit control register. This is useful in testing, for example, to force the transmission of a bad CRC in order to test error detection in the receiver. It can also be useful in certain bridge or switch applications, where end-to-end CRC checking is desired.

### Threshold Logic and Counters

The transmit state machine uses a counter and logic to control the threshold of when transmission can begin. Before it attempts to initiate transmission, the MAC waits until eight bytes or a complete packet has been placed in the transmit FIFO. This gives the DMA engine some latency without causing an underflow during transmission.

### Back-Off and Retransmit Timers

When a collision is detected on the network, the transmitter block stops the transmission and starts a jamming pattern to ensure that all the nodes detect the collision. After this, the transmitter waits for a minimum of 96 bit times and then retransmits the data. After 16 attempts, the transmit state machine sets an error bit and generates an interrupt, if enabled, to signify the failure to transmit a packet due to excessive collisions. It flushes the FIFO, and the MAC is ready for the next packet.

### Transmit Data Parity Checker

Data in the FIFO is odd-parity protected. When data is read for transmission, the transmit state machine checks the parity. If a parity error is detected, the transmit data parity checker does the following:

- It stops transmission.
- It sets the parity error bit in the transmit status register.
- It generates an interrupt, if enabled.

### Transmit State Machine

The transmit state machine is the central control logic for the transmit block. It controls the passing of signals, the timers, and the posting of errors in the status registers.

## THE MAC RECEIVE BLOCK

The MAC receive block is responsible for receiving data. It complies with the IEEE802.3 standard for carrier sense multiple access with collision detection (CSMA/CD) protocol.

After it receives a packet, the receive block checks for a number of error conditions: CRC errors, alignment errors, and length errors. Several of these checks can be disabled by setting bits in the appropriate control registers. depending on the CAM status, the destination address and the receive block may reject an otherwise acceptable packet. The MAC receive block consists of the following units:

- Receive FIFO, FIFO controller, and counters
- Receive BDI state machine
- Threshold logic and counters
- CAM block for address recognition
- Parallel CRC checker
- Receive state machine

The main components of the receive block are shown in Figure 7-4.

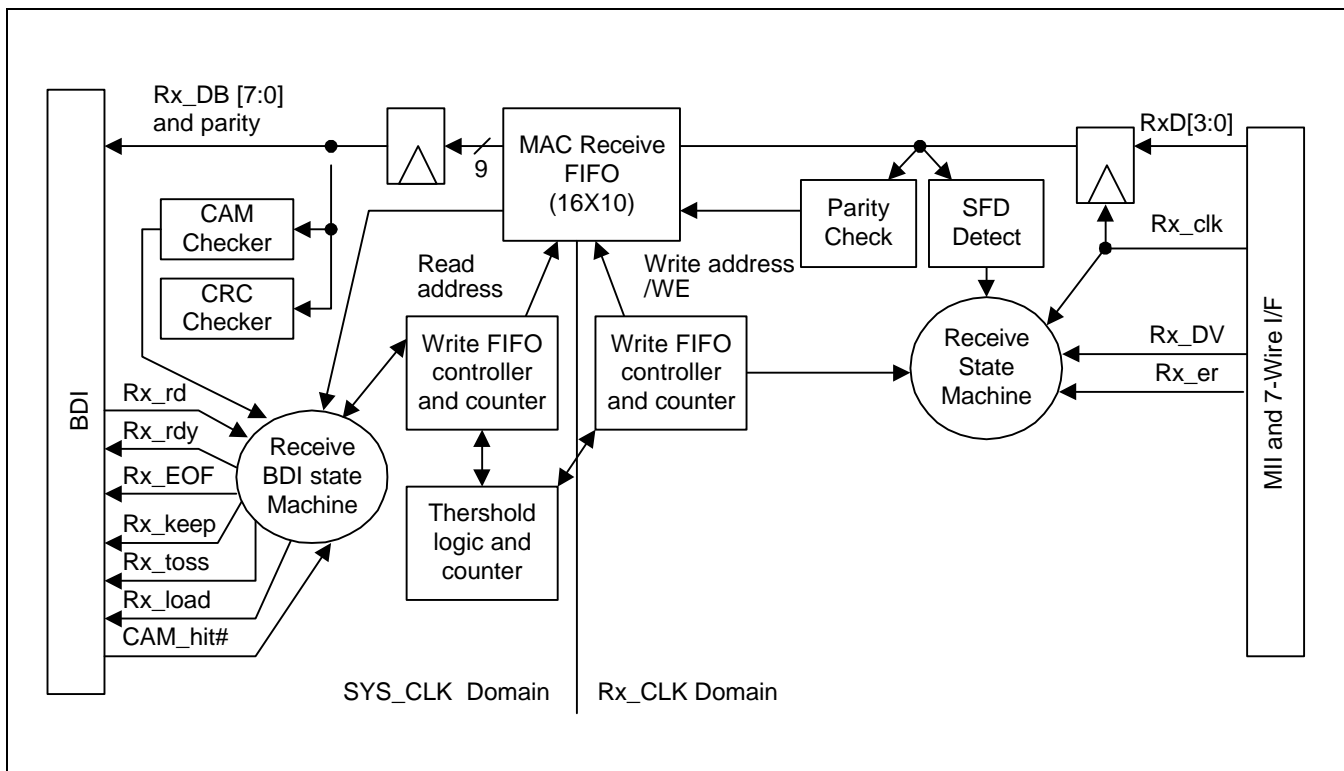

Figure 7-4. MAC Receive Function Blocks



### Receive FIFO Controller

The receive FIFO controller accepts data one byte at a time. Parity starts with the destination address. The receive controller updates the counter with the number of bytes received. As the FIFO stores the data, the CAM block checks the destination address against its stored address. If the CAM recognizes the address, the FIFO continues receiving the packet. If the CAM block does not recognize the address and rejects the packet, the receive block discards the packet and flushes the FIFO.

### Address CAM and Address Recognition

The CAM block provides direct comparison address recognition. The CAM compares the destination address of the received packet to stored addresses. If it finds a match, the receive state machine continues to receive the packet. The CAM is organized to hold six-byte address entries. With its 32-word size, the CAM can store 21 address entries.

CAM address entries 0, 1, and 18 are used to send the pause control packet. To send a pause control packet, you must write the destination address to CAM0, the source address to CAM1, and length/type, op-code, and operand to the CAM18 entry. You must then write the MAC transmit control register to set the send pause control bit. In addition, CAM19 and CAM20 can be used to construct a user-define control frame.

### Parallel CRC Checker

The receive block computes a CRC across the data and the transmitted CRC, and then checks that the resulting syndrome is valid. A parallel CRC checking scheme handles data arriving in 4-bit nibbles at 100 Mbps. To support full-duplex operation, the receive and transmit blocks have independent CRC circuits.

### Receive State Machine

In MII mode, the receive block receives data from the MII on the RxD[3:0] lines. This data is synchronized to Rx\_clk at 25 MHz or 2.5 MHz. In 7-wire mode, and at 10 MHz, data is received on the RxD\_10 line only.

After it detects the preamble and SFD, the receive state machine arranges data in byte configurations, generates parity, and stores the result in the receive FIFO one byte at a time. If the CAM block accepts the destination address, the receive FIFO stores the rest of the packet. At the end of the reception, the receive block marks the packet received by setting the appropriate bits in the receive status register. Any error in reception will reset the FIFO and the state machine will wait for the end of the current packet. It will then idle while it is waiting for the next preamble and SFD.

### BDMA Interface Receive State Machine

The BDMA I/F receive state machine issues the Rx\_rdy signal to request that the receive FIFO have data whenever data is present in the receive FIFO. The last byte of the packet is signaled by asserting the Rx\_EOF. In case there are any errors during the reception, or if there is a CRC error at the end, the BDMA I/F receive state machine asserts the Rx\_toss signal to indicate that the received packet should be discarded.

## FLOW CONTROL BLOCK

The flow control block provides for the following functions:

- Recognition of MAC control frames received by the receive block
- Transmission of MAC control frames, even if transmitter is paused
- Timers and counters for pause operation
- Command and status register (CSR) interface
- Options for passing MAC control frames through to software drivers

The receive logic in the flow control block recognizes a MAC control frame as follows:

- The length/type field must have the special value specified for MAC control frames. The destination address must be recognized by the CAM. The frame length must be 64 bytes, including CRC. The CRC must be valid, and the frame must contain a valid pause op-code and operation.
- If the length/type field does not have the special value specified for MAC control frames, the MAC takes no action, and the packet is treated as a normal packet. If the CAM does not recognize the destination address, the MAC rejects the packet. If the packet length is not 64 bytes, including CRC, the MAC does not perform the operation. The packet is then marked as a MAC control packet, and is passed forward to the software drivers, if pass-through is enabled.

You can set control bits in the transmit status register to generate a Full-Duplex pause operation or other MAC control functions, even if the transmitter itself is paused. Two timers and two corresponding CSR registers are used during a pause operation. One timer/register pair is used when a received packet causes the transmitter to pause. The other pair is used to approximate the pause status of the other end of the link, after the transmitter sends a Pause command.

The command and status register (CSR) interface provides control and status bits within the transmit and receive control registers and status registers. These lets you initiate the sending of a MAC control frame, enable and disable MAC control functions, and read the values of the flow control counters.

Control bits are provided for processing MAC control frames entirely within the controller, or for passing MAC control frames on to the software drivers. This lets you enable flow control by default even on software drivers which are not otherwise "flow control aware".

## BUFFERED DMA INTERFACE

### BUFFERED DMA (BDMA) CONTROL BLOCKS

The BDMA engine controls a transmit buffer and a receive buffer. The BDMA transmit buffer holds data and status information for packets being transmitted. The BDMA receive buffer holds data and status information for packets being received. Each FIFO has a control block which controls data being placed in, and removed from, the buffers.

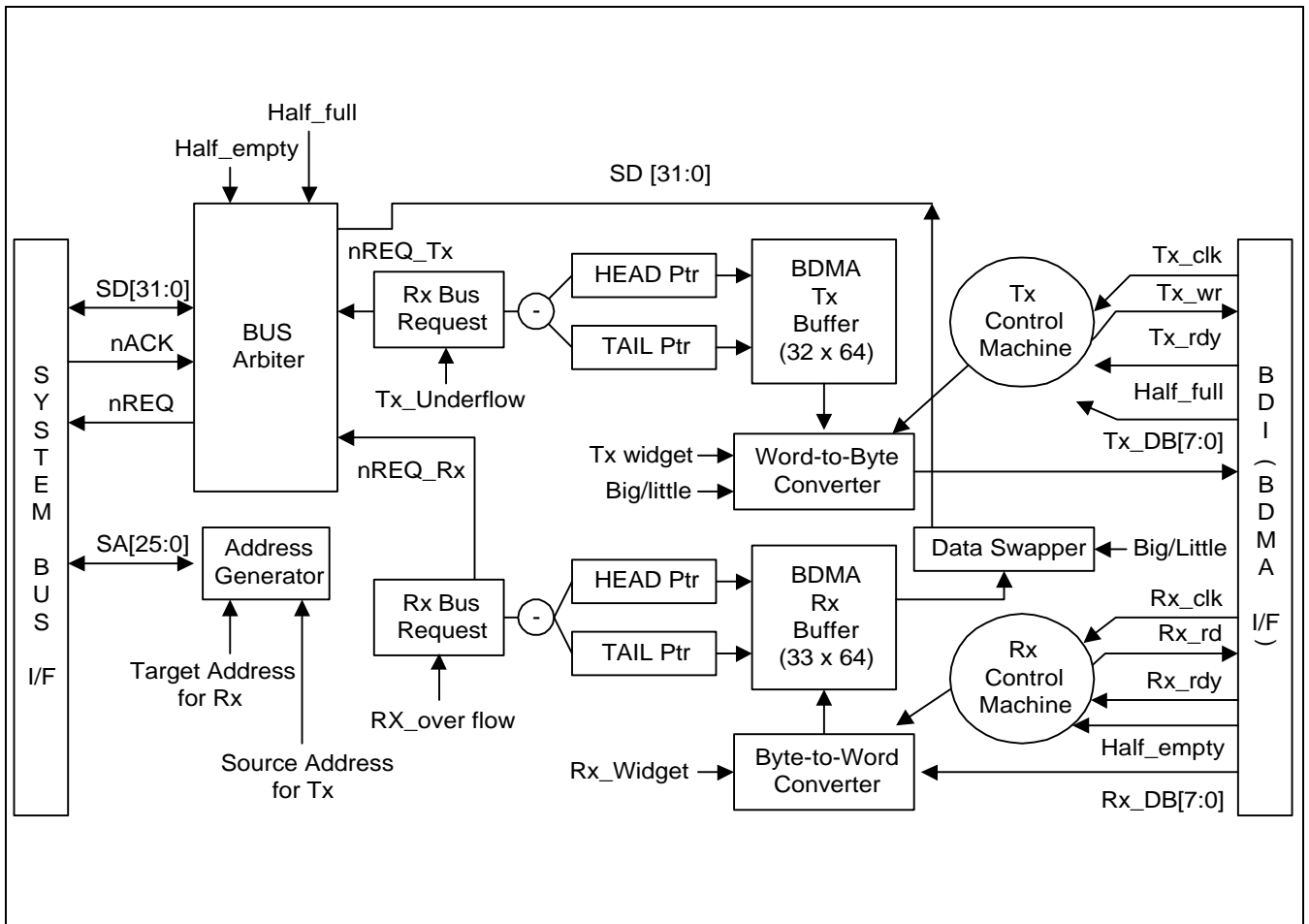

Figure 7-5. BDMA Control Blocks

### The Bus Arbiter

The bus arbiter decides which of the BDMA buffer controllers, transmit (Tx) or receive (Rx), has the highest priority for accessing the system bus. The prioritization is dynamic. The BDMA arbiter outputs a bus request signal (nREQ) to the system manager when

- A buffer contains more words than the Rx burst size,
- An EOF (End of Frame) was saved to the buffer, or
- A buffer contains more free space than the Tx burst size.

After it receives a bus acknowledge signal (nACK) from the system manager, the BDMA bus arbiter determines the correct bus access priority. If nREQ\_Tx and nREQ\_Rx were requested simultaneously, the bus arbiter decodes the nACK signal using the following method:

```
switch (Half_empty, Half_full)
{ case 2'b01: nACK_Rx ← nACK
  case 2'b10: nACK_Tx ← nACK
  default: //case 2'b00 or 2'b11:
    if (Rx bufsize (Head - Tail) < Tx bufsize) // Rx more urgent
      nACK_Rx ← nACK
    else nACK_Tx ← nACK}
```

### BDMA Bus Control Logic

The function blocks of the BDMA controller provide logic for controlling bus master read and write operations across the system bus. This control logic supports the following operations:

- Burst size control, to optimize system bus utilization.
- Transmit threshold control (based on 1/8 of transmit buffer size) to match transmission latency to system bus latency.
- Little-Endian byte swapping, to support the data transfer of Little-Endian memory usage for frame data.
- A transmit/receive alignment widget to circumvent word alignment restrictions.

In systems with an ATM LAN emulation or an MPOA interface, and in certain other systems as well, the beginning of a packet should be placed on a byte or half-word boundary. You may not, however misalign the BDMA transfer, as this would complicate the design of the DMA, and would degrade performance. To avoid this, you can use an alignment widget between the BDMA buffer (word) and the MAC FIFO (byte).

In the receiver, the BDMA bus control logic inserts a programmable number of bytes (up to three) into the received data stream while the preamble is being received. This adds some padding to the beginning of the frame. This padding can then be used to solve alignment problems downstream, without having to use a copy of the buffer. Because there is never more than three bytes, this feature does not degrade performance. Also, because the data is inserted prior to the concatenation of bytes into words, it does not misalign the subsequent DMA transfer.

The length of the alignment data is read from a control register. This length value should be set by software immediately after the MAC module is reset, and it should not be modified.

You can use a corresponding transmit alignment widget to remove data from the buffer. In the simplest implementation, the widget discards the first "n" bytes (up to three), where "n" is the value read from the transmit frame descriptor which configures the transmit alignment widget.

### MEMORY DATA STRUCTURES

The flow control 100-/10-Mbit/s ethernet controller uses three data structures to exchange control information and data:

- Transmit frame descriptor
- Receive frame descriptor
- Frame data buffer

Each frame descriptor has the following elements:

- Frame start address
- Ownership bit
- Control field for transmitter
- Status field
- Frame length
- Next frame descriptor pointer

Figure 7-6 shows data structures of the transmit and receive frame descriptors.

## DATA FRAMES

The ownership bit in the MSB of the frame start address controls the owner of the descriptor. When the ownership bit is "1", the BDMA controller owns the descriptor. When this bit is "0", the CPU owns the descriptor. The owner of the descriptor always owns the associated data frame. (The descriptor's frame start address field always points to this frame.)

As it receives the data frame, software sets the maximum frame size register in the BDMA block to the system frame buffer size (typically, to 1536 or 2048). Software also sets the Rx frame descriptor start address register to point to a chain of frame descriptors, all of which have their ownership bit set.

The BDMA engine can then be started to set the BDMA receive enable bit in the BDMARXCON register. When a frame is received, it is copied into memory at the address specified by the Rx frame start address. Please note that no configurable offset or page boundary calculation is required. The received frame is written into the frame data buffer until the end of frame is reached, or until the length exceeds the configured maximum frame size.

If the entire frame is received successfully, the status bits in the frame descriptor are set to indicate this. Otherwise, the status bits are set to indicate that an error occurred. The ownership bit in the frame start address field is cleared and an interrupt may now be generated. The BDMA controller copies the next frame descriptor register value into the Rx frame descriptor start address register. If the next frame descriptor address is null (0), the BDMA simply halts, and all subsequent frames are dropped. Otherwise, the descriptor is read in, and the BDMA controller starts again with the next frame, as described in the previous paragraph.

If the received frame size exceeds the maximum frame size, the data frame will be overwritten by the last word of maximum frame. The overflow data is written to the Rx status bit [19] in the receive frame descriptor. When the BDMA reads a descriptor, if the ownership bit is not set, it has two options:

- Skip to the next frame descriptor, or
- Generate an interrupt and halt the BDMA operation.

Transmit frame descriptors contain the following components:

- A four-byte pointer to the frame data
- Widget alignment control bits [6:5]
- Frame data pointer increment/decrement bit [4]
- Little-Endian control bit [3]
- Interrupt enable after transmit [2]
- No-CRC [1], and
- No-padding [0]

During transmission, the two-byte frame length at the Tx frame descriptor is moved into the BDMA internal Tx register. After transmission, Tx status is saved in the Tx frame descriptor. The BDMA controller then updates the next frame descriptor address register for the linked list structure.

When the Tx frame descriptor start address register points to the first frame buffer, transmitter starts transmitting the frame data into the frame buffer memory.

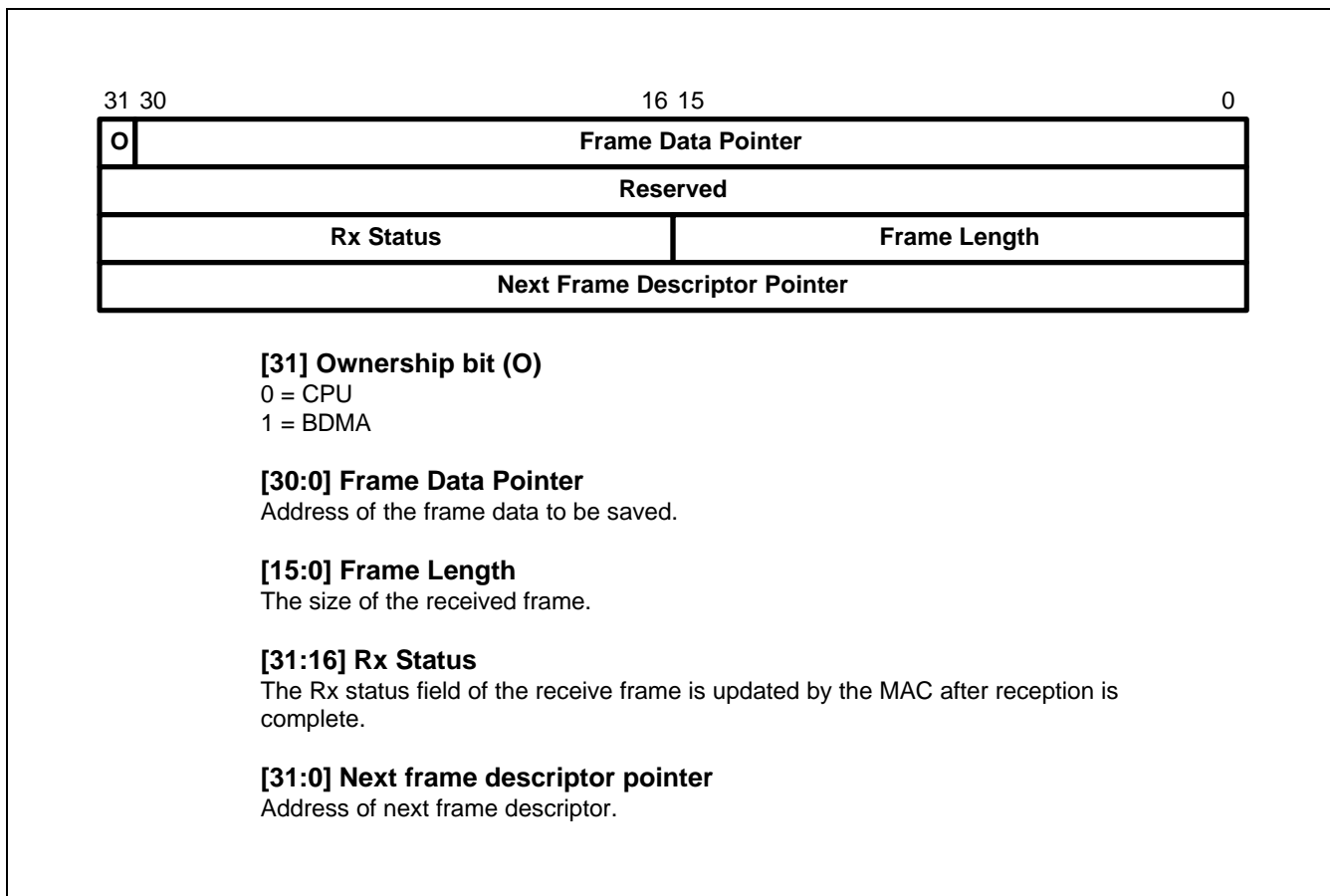

Figure 7-6. Data Structure of Rx Frame Descriptor





## Rx Status

31	30	29	28	27	26	25	24	23	22	21	20	19	18	17	16
RxHalted	Good	RxPar	0	LongErr	Overflow	CRCErr	AlignErr	Rx10Stat	IntRx	CtlRcv	0	OvMax	0	0	0

**[19] Over maximum size (OvMax)**

Set if the received frame data size exceeds the maximum frame size.

**[21] Control received (CtlRcv)**

Set if the received packet is a MAC control frame.

**[22] Interrupt on receive (IntRx)**

Set if reception of packet caused an interrupt condition. This includes Good received, if the Engood bit, MACRXCON [14], is set.

**[23] Receive 10 Mb/s status (Rx10stat)**

Set if packet was received over the 7-wire interface. Reset if packet was received over the MII.

**[24] Alignment error (AlignErr)**

Frame length in bits was not a multiple of eight and the CRC was invalid.

**[25] CRC Error (CRCErr)**

CRC at end of packet did not match the computed value, or else the PHY asserted Rx\_er during packet reception.

**[26] Overflow error (Overflow)**

The MAC receive FIFO was full when it needed to store a received byte.

**[27] Long error (LongErr)**

Received a frame longer than 1518 bytes. Not set if the long enable bit set to one in the receive control register.

**[29] Receive parity error (RxPar)**

MAC receive FIFO has detected a parity error.

**[30] Good received (Good)**

Successfully received a packet with no errors. If EnGood = 1, an interrupt is generated on each packet that is received successfully.

**[31] Reception halted (RxHalted)**

Reception interrupted by user clearing RxEN or setting HaltImm in the MAC control register.

Figure 7-8. Rx Descriptor Status Bits

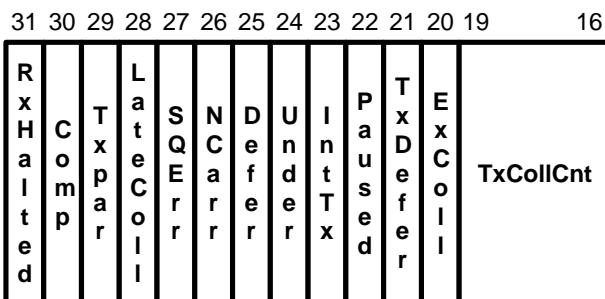
**Tx Status****[19:16] Transmit collision count (TxCollCnt)**

Count of collisions during transmission of a single packet. After 16 collisions, TxColl is zero, and ExColl is set.

**[20] Excessive collision (ExColl)**

16 collisions occurred in the same packet.

**[21] Transmit deferred (TxDefer)****[22] Paused****[23] Interrupt on transmit (IntTx)**

Set if transmission of packet caused an interrupt condition. This includes the enable completion (EnComp), MACTXCON [14], if enabled.

**[24] Underrun (Under)**

MAC transmit FIFO becomes empty during transmission.

**[25] Deferral (Defer)**

MAC defers for max\_deferral 0.32768ms for 100Mbit/s or 3.27680ms for 10Mbit/s.

**[26] No carrier (NCarr)**

Carrier sense is not detected during the entire transmission of a packet (from the SFD to the CRC).

**[27] SQE error (SQErr)**

After transmit frame, set if the fake collision (COL) signal did not come from the PHY for 1.6  $\mu$ s.

**[28] Late collision (LateColl)**

A collision occurred after 512 bit times (64 byte times)

**[29] Transmit parity error (TxPar)**

MAC transmit FIFO detected a parity error.

**[30] Completion (Comp)**

MAC complete a transmit or discard of one packet.

**[31] Transmission halted (TxHalted)**

Transmission halted by clearing RxEn or setting the HaltImm in the MAC control register. Or, an interrupt was generated by an error condition (not completion).

**Figure 7-9. Tx Descriptor Status Bits**

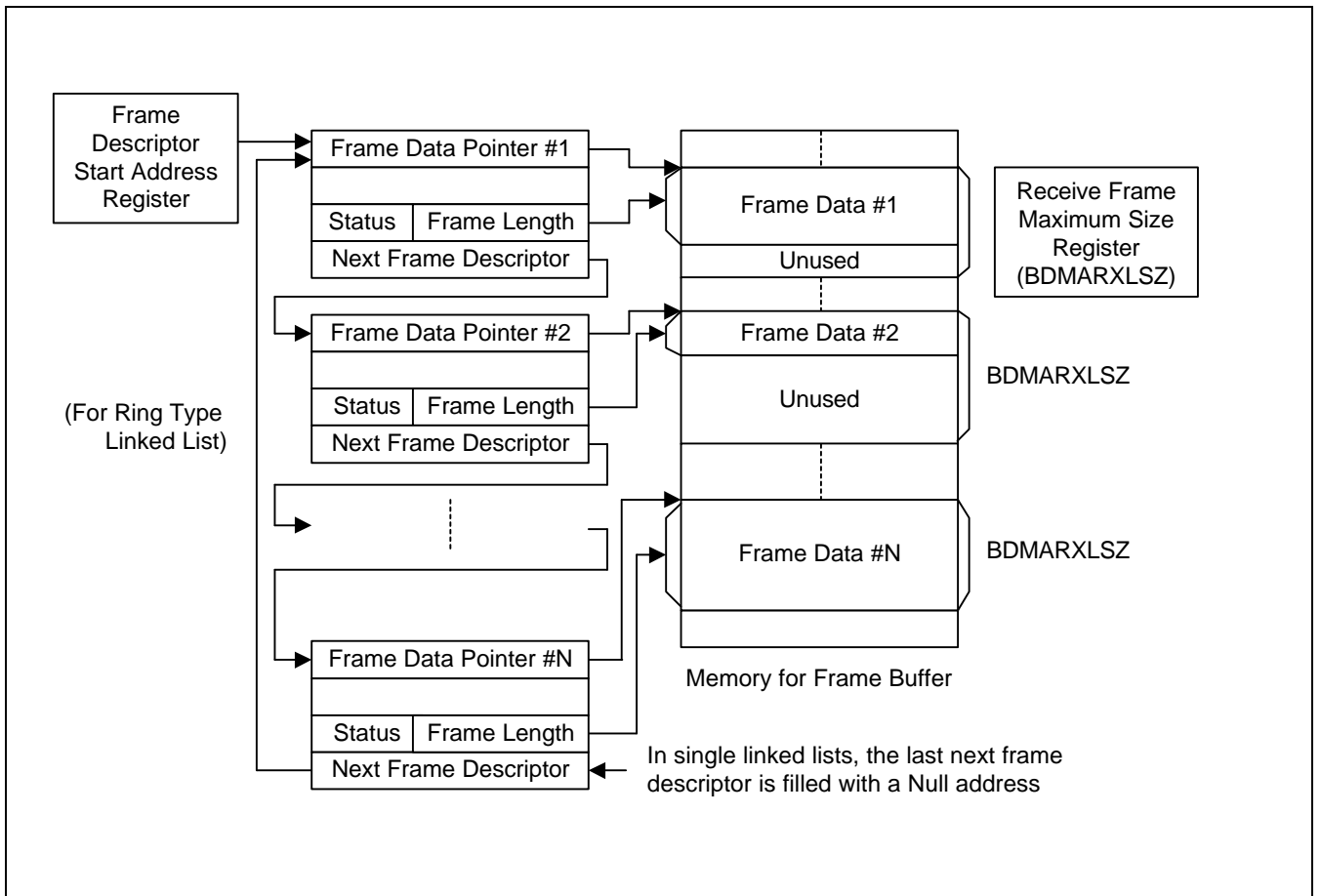

Figure 7-10. Data Structure of the Receive Frame Data Buffer

## ETHERNET CONTROLLER SPECIAL REGISTERS

The special registers used by the S3C4510B ethernet controller are divided into two main groups:

- BDMA control and status registers
- MAC control and status registers

### BDMA CONTROL AND STATUS REGISTERS

All registers that contain a memory address must store the address in a word-aligned format.

**Table 7-2. BDMA Control and Status Registers**

Registers	Offset	R/W	Description	Reset Value
BDMATXCON	0x9000	R/W	Buffered DMA transmit control register	0x00000000
BDMARXCON	0x9004	R/W	Buffered DMA receive control register	0x00000000
BDMATXPTR	0x9008	R/W	Transmit frame descriptor start address	0xFFFFFFFF
BDMARXPTR	0x900C	R/W	Receive frame descriptor start address	0xFFFFFFFF
BDMARXLSZ	0x9010	R/W	Receive frame maximum size	Undefined
BDMASTAT	0x9014	R/W	Buffered DMA status	0x00000000
CAM	0x9100–0x917C	W	CAM content (32 words)	Undefined
BDMATXBUF (1)	0x9200–0x92FC	R/W	BDMA transmit (Tx) buffer (64 words) for test mode addressing only	Undefined
BDMARXBUF (1)	0x9800–0x98FC 0x9900–0x99FC	R/W	BDMA receive (Rx) buffer (64 words) for test mode addressing only	Undefined

**NOTES:**

1. For testing, you can read the BDMA Tx/Rx buffer directly. The BDMA receive buffer has a 64 word by 33 bit size. The highest bit, [32], indicates the data frame boundary, as shown in the following illustration:

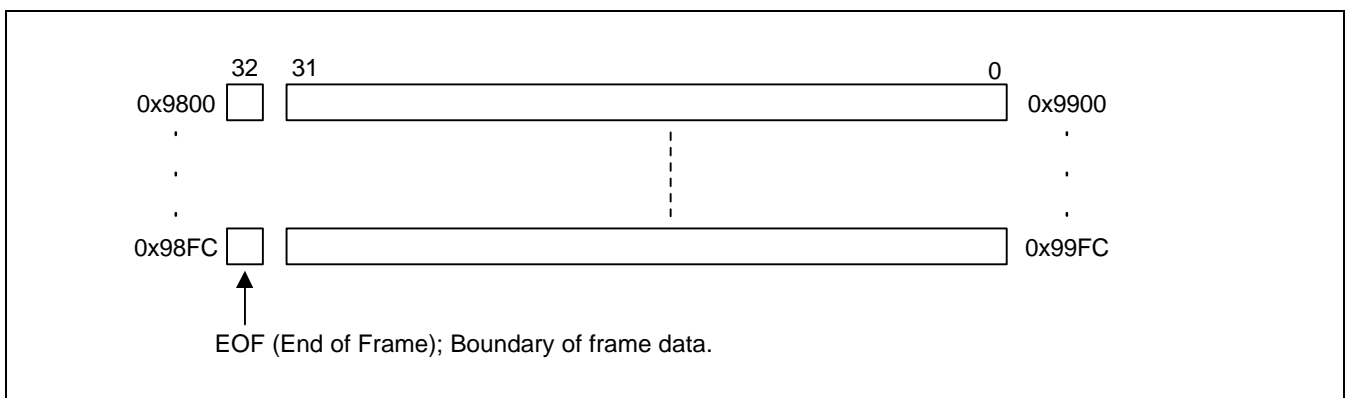

**Figure 7-11. End of Frame Bit**

2. You can access the EOF bit by reading the address range, 0x9800-0x98FC (read into LSB bit 0).

### Buffered DMA Transmit Control Register

The buffered DMA transmit control register, BDMATXCON, is described in Tables 7-3 and 7-4 below.

**Table 7-3. BDMATXCON Register**

Registers	Offset	R/W	Description	Reset Value
BDMATXCON	0x9000	R/W	Buffered DMA transmit control register	0x00000000

**Table 7-4. BDMA Transmit Control Register Description**

Bit Number	Bit Name	Description
[4:0]	BDMA Tx burst size (BTxBRST)	(Word size + 1) of data bursts requested in BDMA mode. If the BTxBRST is zero, the burst size is one word. If the BTxBRST is 31, the burst size is 32 words.
[5]	BDMA Tx stop/skip frame by owner bit (BTxSTSKO)	This bit determines whether the BDMA Tx controller issues an interrupt, if enabled, or skips the current frame and goes to the next frame descriptor (assuming BDMA is not the owner).
[6]	Reserved	Not applicable.
[7]	BDMA Tx complete to send control packet interrupt enable (BTxCCPIE)	Setting this bit enables the BDMA Tx complete to send control packet interrupt when the MAC has finished sending the control packet.
[8]	BDMA Tx Null list interrupt enable (BTxNLIE)	This bit enables the BDMA Tx Null list interrupt which indicates that the transmit frame descriptor start address pointer, BDMATXPTR, in the BDMA Tx block has a null (0x00000000) address.
[9]	BDMA Tx not owner interrupt enable (BTxNOIE)	This bit enables the BDMA Tx not owner interrupt when the ownership bit of the current frame does not belong to the BDMA controller, and if the BTxSTSKO bit is set.
[10]	BDMA Tx buffer empty interrupt enable (BTxEmpty)	Set this bit is "1" to enable the Tx buffer empty interrupt.
[13:11]	BDMA transmit to MAC Tx start level (BTxMSL)	These bits determine when the new frame data in BDMA Tx buffer can be moved to the MAC Tx FIFO when a new frame arrives. 000 means no wait, 001 means wait to fill 1/8 of the BDMA Tx buffer, 010 means wait to fill 2/8 of the buffer, 011 for 3/8 and 1xx for 4/8. <b>NOTE:</b> If the last data of the frame arrives in BDMA Tx buffer, the data transfer from the BDMA Tx buffer to the MAC Tx FIFO starts immediately, regardless of the level of these bits.

Table 7-4. BDMA Transmit Control Register Description (Continued)

Bit Number	Bit Name	Description
[14]	BDMA Tx enable (BTxEn)	<p>When the Tx enable bit is set to "1", the BDMA Tx block is enabled. Even if this bit is disabled, buffer data will be moved to the MAC Tx FIFO until the BDMA Tx buffer underflows (as long as the FIFO is not empty and the MAC Tx is enabled). This bit is automatically disabled in the following cases: 1) if the next frame pointer is null, or 2) if the owner bit is zero, and the BTxSTSKO bit is set.</p> <p>NOTE: The frame descriptor start address pointer must be assigned before the BDMA Tx enable bit is set.</p>
[15]	BDMA Tx reset (BTxRS)	Set this bit to "1" to reset the BDMA Tx block.



**Buffered DMA Receive Control Register**

The buffered DMA receive control register, BDMARXCON, is described in Tables 7-5 and 7-6 below.

**Table 7-5. BDMA RXCON Register**

Register	Offset Address	R/W	Description	Rest Value
BDMARXCON	0x9004	R/W	Buffered DMA receive control register	0x00000000

**Table 7-6. BDMA Receive Control Register Description**

Bit Number	Bit Name	Description
[4:0]	BDMA Rx burst size (BRxBRST)	(Word size + 1) of data bursts requested in BDMA mode. If the BRxBRST is zero, the burst size is one word. If the BRxBRST is 31, the burst size is 32 words.
[5]	BDMA Rx stop/skip frame by owner bit (BRxSTSKO)	This bit determines whether the BDMA Rx controller issues an interrupt, if enabled, or skips the current frame and goes to the next frame descriptor (assuming BDMA is not the owner).
[6]	BDMA Rx memory address inc/dec (BRxMAINC)	This bit determines whether the address is incremented or decremented. If this bit is set to "1", the address will be incremented.
[7]	BDMA Rx every received frame interrupt enable (BRxDIE)	This bit enables the BDMA Rx every received frame interrupt which is generated by the BDMA controller each time it moves a complete data frame into memory.
[8]	BDMA Rx Null list interrupt enable (BRxNLIE)	This bit enables the BDMA Rx null list interrupt which indicates that the receive frame descriptor start address pointer, BDMARXPTR, in the BDMA Rx block has a null (0x00000000) address.
[9]	BDMA Rx not owner interrupt enable (BRxNOIE)	This bit enables the BDMA Rx not owner interrupt when the ownership bit of the current frame does not belong to the BDMA controller, and if the BRxSTSKO bit is set.
[10]	BDMA Rx maximum size over interrupt enable (BRxMSOIE)	This bit enables the BDMA Rx maximum size over interrupt when the received frame size is larger than the value in receive frame maximum size register.
[11]	BDMA Rx Big/Little Endian (BRxLittle)	This bit determines whether the data is stored in Little- or Big-Endian format. If it is set to "1", word swapping will take place between the receive buffer and the system data bus.
[13:12]	BDMA Rx word alignment (BRxWA)	The Rx word alignment bits determine how many bytes are invalid in the first word of each data frame. These invalid bytes are inserted when the word is assembled by the BDMA controller. "00" = No invalid bytes, "01" = 1 invalid byte, "10" = 2 invalid bytes, and "11" = 3 invalid bytes.



Table 7-6. BDMA Receive Control Register Description (Continued)

Bit Number	Bit Name	Description
[14]	BDMA Rx enable (BRxEn)	When the Rx enable bit is set to "1", the BDMA Rx block is enabled. Even if this bit is disabled, the MAC will receive Rx data until the MAC Rx FIFO overflows (as long as the FIFO is not empty and the MAC Rx is enabled). This bit is automatically disabled in the following cases: 1) if the next frame pointer is Null, or 2) if the owner bit is zero, and the BRxSTSKO bit is set.  NOTE: The frame descriptor start address pointer must be assigned before the BDMA Rx enable bit is set.
[15]	BDMA Rx reset (BRxRS)	Set this bit to "1" to reset the BDMA Rx block.
[16]	BDMA Rx buffer empty interrupt enable (BRxEmpty)	Set this bit is "1" to enable the Rx buffer empty interrupt.
[17]	BDMA Rx early notify interrupt enable (BRxEarly)	Set this bit to "1" to enable the Rx early notify interrupt. The function of this interrupt is to note the length of a data frame that is being received from its frame length field.

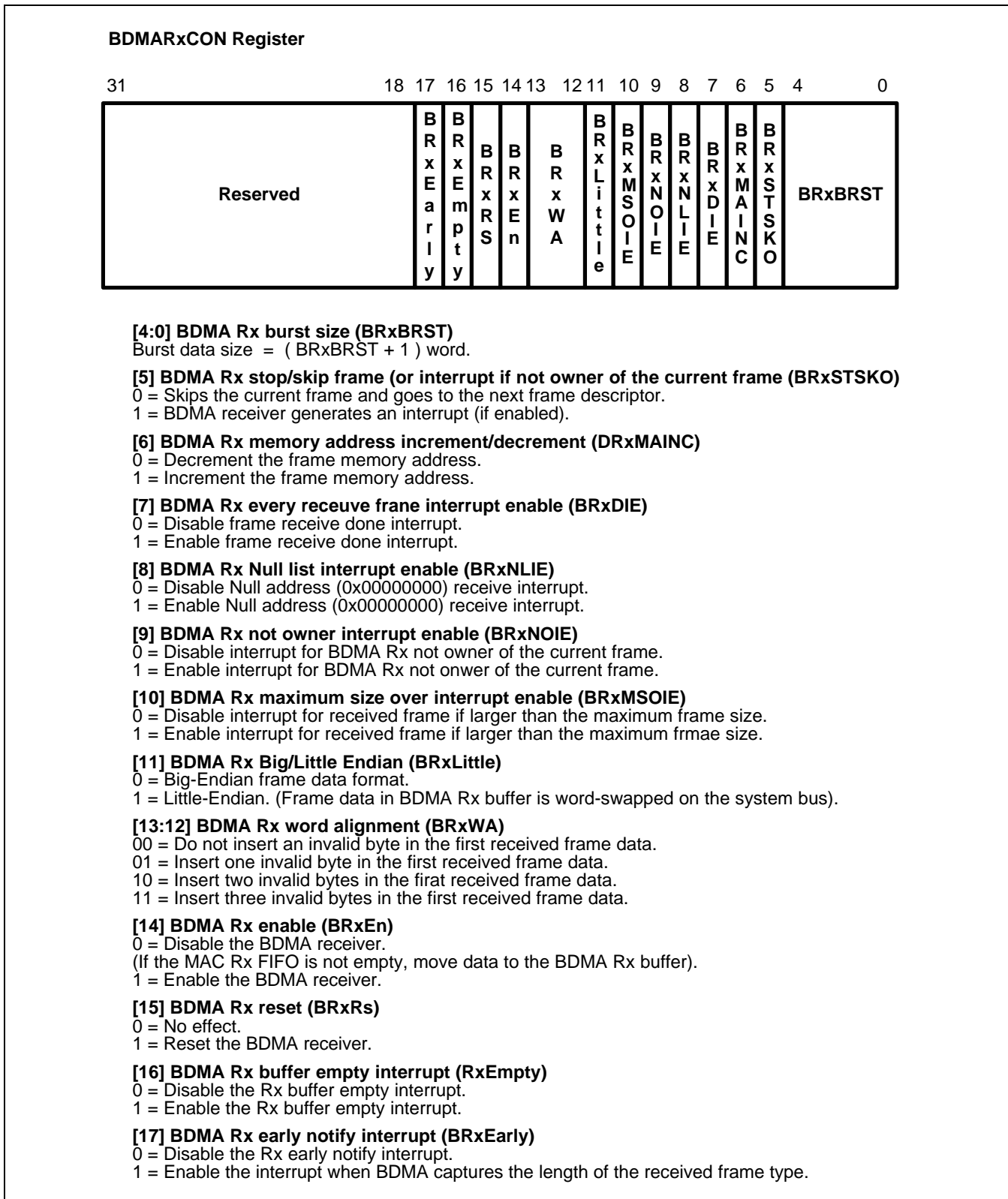

Figure 7-13. Buffered DMA Receiver Control Register

## BDMA Transmit Frame Descriptor Start Address Register

Table 7-7. BDMATXPTR Register

Registers	Offset	R/W	Description	Reset Value
BDMATXPTR	0x9008	R/W	Buffered DMA transmit control register	0xFFFFFFFF

Table 7-8. BDMA Transmit Frame Descriptor Start Address Register Description

Bit Number	Bit Name	Description
[25:0]	BDMA transmit frame descriptor start address	The BDMA transmit frame descriptor start address register contains the address of the frame descriptor on the frame to be sent. During a BDMA operation, this start address pointer is updated to the next frame address.

## BDMA Receive Frame Descriptor Start Address Register

Table 7-9. BDMARXPTR Register

Registers	Offset	R/W	Description	Reset Value
BDMARXPTR	0x900C	R/W	Buffered DMA transmit control register	0xFFFFFFFF

Table 7-10. BDMA Receive Frame Descriptor Start Address Register Description

Bit Number	Bit Name	Description
[25:0]	BDMA receive frame descriptor start address	The BDMA receive frame descriptor start address register contains the address of the frame descriptor on the frame to be saved. During a BDMA operation, this start address pointer is updated to the next frame address.

## BDMA Receive Frame Maximum Size Register

Table 7-11. BDMARXLSZ Register

Registers	Offset	R/W	Description	Reset Value
BDMARXLSZ	0x9010	R/W	Receive frame maximum size	Undefined

Table 7-12. BDMA Receive Frame Maximum Size Register Description

Bit Number	Bit Name	Description
[15:0]	BDMA receive frame maximum size (BRxLSZ)	This register value controls how many bytes per frame can be saved to memory. If the received frame size exceeds the value stored in this location, an error condition is reported.
[31:16]	BDMA receive frame length (BRxFSZ), read-only	<p>When an early notification (early notify) interrupt occurs, the frame Length/Ethernet type field contains the Frame size of the frame that is currently being received.</p> <p>To save space in the frame memory buffer, you can determine the current frame length by 1) enabling the early notification interrupt, and 2) reading the BRxFSZ field when the interrupt occurs.</p> <p>To calculate the value of the next frame start address pointer, you add the current frame size value (BRxFSZ) to the BDMA receive start address register. (For a control packet, additional space may be needed.)</p> <p>NOTE: To obtain the next Rx frame address that is to be saved in the Rx frame start address register, we recommend that you first halt the BDMA operation.</p>

## BDMA Status Register

Table 7-13. BDMASSTAT Register

Registers	Offset	R/W	Description	Reset Value
BDMASSTAT	0x9014	R/W	Buffered DMA status	0x00000000

Table 7-14. BDMA Status Register Description

Bit Number	Bit Name	Description
[0]	BDMA Rx done every received frame (BRxRDF)	This bit is set each time the BDMA receiver moves one received data frame to memory. This bit must be cleared for the receiving next frame interrupt generation.
[1]	BDMA Rx null list (BRxNL)	If this bit is set, the BDMARXPTR has a null address. Even if BDMA Rx is disabled, data is transferred from the MAC Rx FIFO to the BDMA Rx buffer until the BDMA Rx buffer overflows.
[2]	BDMA Rx not owner (BRxNO)	If this bit is set, BDMA is not the owner of the current data frame. The BRxSTSKO bit is set and BDMA Rx is stopped.
[3]	BDMA Rx maximum size over (BRxMSO)	If this bit is set, the received frame size is larger than the value in the Rx frame maximum size register, BDMARXLSZ.
[4]	BDMA Rx buffer empty (BRxEmpty)	If this bit is set, the BDMA Rx buffer is empty.
[5]	Early notification (BRxSEarly)	This bit is set when the BDMA receiver has received the length/Ether-type field of the current frame.
[6]	Reserved	Not applicable.
[7]	One more frame data in BDMA receive buffer (BRxFRF)	This bit is set whenever an additional data frame is received in the BDMA receive buffer.
[15:8]	Number of frames in BDMA receive buffer (BRxNFR)	This value indicates the total number of data frames currently in the BDMA receive buffer.
[16]	BDMA Tx complete to send control packet (BTxCCP)	Bit [16] is set each time the MAC sends a complete control packet.
[17]	BDMA Tx null list (BTxNL)	If this bit is set, the BDMATXPTR value is a null address. In this case, BDMA Tx is disabled but data continues to be transferred from the BDMA Tx buffer to the MAC Tx FIFO until the BDMA Tx buffer underflows. This bit is read only. If you set BDMA Tx reset bit by software, this bit is cleared automatically. To resume data transfer, you must then set the new frame descriptor pointer and enable BDMA Tx.
[18]	BDMA Tx not owner (BTxNO)	If [18] is set, BDMA is not owner of the current frame. In this case, the BSTSKO bit is set and BDMA Tx is stopped.
[19]	Reserved	Not applicable.
[20]	BDMA Tx buffer empty (BTxEmpty)	If this bit is set, the BDMA Tx buffer is empty.
[31:21]	Reserved	Not applicable.

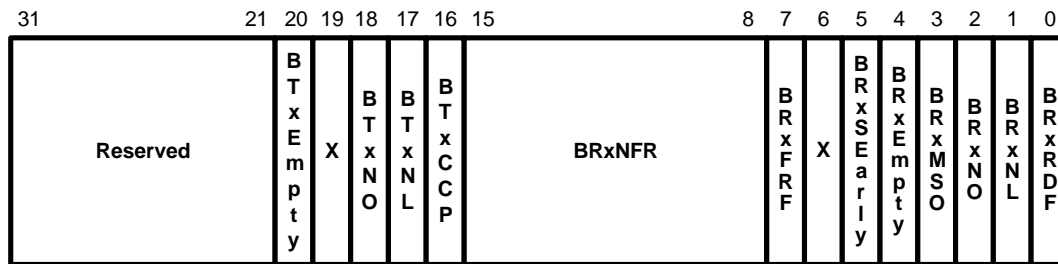

**[0] BDMA Rx done event received frame (BRxRDF)**

0 = Reset frame data receive state.  
1 = Receipt of the data frame is complete.

**[1] BDMA Rx Null list (BRxNL)**

0 = Reset state of new frame descriptor (BDMARXPTR) is set.  
1 = Current frame descriptor address is Null (0x00000000).

**[2] BDMA Rx not owner (BRxNO)**

0 = BDMA is owner of the current frame.  
1 = The owner of the current frame is not BDMA (CPU). In this case, BDMA Rx is stopped and the BSTSKO bit is set.

**[3] BDMA Rx maximum size over (BRxMSO)**

0 = Reset state or next frame arrived at BDMA Rx buffer.  
1 = Received frame exceeds the maximum frame size.

**[4] BDMA Rx buffer empty (BRxEmpty)**

0 = Not empty.  
1 = BDMA Rx buffer empty.

**[5] Early notify (BRxSEarly)**

0 = Normal operation.  
1 = Length of current frame can be accessed by reading the BDMA receive maximum frame size register, BDMARXLSZ [31:16].

**[7] One more frame data in BDMA receive buffer (BRxFRF)**

0 = Only one frame data in BDMA receive buffer.  
1 = One more frame data was in the BDMA receive buffer.

**[15:8] Number of frame data in BDMA receive buffer (BRxNFR)**

**[16] BDMA Tx complete to send control packet (BTxCCP)**

0 = Clear but by writing a 1 to this bit or by resetting BDMA Tx.  
1 = MAC complete to send the control packet.

**[17] BDMA Tx Null list (BTxNL)**

0 = Reset stste of new frame descriptor (BDMATXPTR) is set.  
1 = Current frame descriptor address is Null (0x00000000).

**[18] BDMA Tx not owner (BTxNO)**

0 = BDMA is owner of the current frame.  
1 = The owner of the current frame is not BDMA (CPU). In this case, BDMA Tx is stopped if the BTxSTSKO bit is set to one.

**[19] Reserved**

**[20] BDMA Tx buffer empty (BTxEmpty)**

0 = Not empty  
1 = BDMA Tx buffer empty.

**[31:21] Reserved**

**NOTE:** Bit 0, 1, 2, 3, 4, 16, 17, 18 and 20 should be cleared for interrupt generation for the next frame. The method is write 1 to the corresponding bit location.

Figure 7-14. BDMA Status Register

### Content Address Memory (CAM) Register

There are 21 CAM entries for the destination address and the pause control packet. For the destination address CAM value, one destination address consists of 6 bytes. Using the 32-word space ( $32 \times 4$  bytes), you can therefore maintain up to 21 separate destination addresses.

You use CAM entries 0, 1, and 18 to send pause control packets. To send a pause control packet, you write the CAM0 entry with the destination address, the CAM1 entry with the source address, and the CAM 18 entry with length/type, opcode, and operand. You then set the send pause bit in the MAC transmit control register.

**Table 7-15. CAM Register**

Registers	Offset	R/W	Description	Reset Value
CAM	0x9100–0x917C	W	CAM content (32 words)	Undefined

**Table 7-16. Content Address Memory (CAM) Register Description**

Bit Number	Bit Name	Description
[31:0]	CAM content (CAM)	The CPU uses the CAM content register as a data base for destination address. To activate the CAM function, you must set the appropriate enable bits in CAM enable register.

**MEDIA ACCESS CONTROL (MAC) REGISTERS**

This section describes the control and status registers for the flow control 100-/10-Mbit/s ethernet MAC. These include a master MAC control register, control registers for transmit and receive, control registers for the CAM, a counter for network management, and various flow control registers (see Table 7-17).

**Table 7-17. MAC Control and Status Registers**

Registers	Offset	R/W	Description	Reset Value
MACON	0XA000	R/W	MAC control	0x00000000
CAMCON	0xA004	R/W	CAM control	0x00000000
MACTXCON	0xA008	R/W	Transmit control	0x00000000
MACTXSTAT	0xA00C	R/W	Transmit status	0x00000000
MACRXCON	0xA010	R/W	Receive control	0x00000000
MACRXSTAT	0xA014	R/W	Receive status	0x00000000
STADATA	0xA018	R/W	Station management data	0x00000000
STACON	0xA01C	R/W	Station management control and address	0x00006000
CAMEN	0xA028	R/W	CAM enable	0x00000000
EMISSCNT	0xA03C	RClr/W	Missed error count	0x00000000
EPZCNT	0xA040	R	Pause count	0x00000000
ERMPZCNT	0xA044	R	Remote pause count	0x00000000
ETXSTAT	0x9040	R	Transmit control frame status	0x00000000

**NOTE:** MAC transmit/receive interrupt is generated whenever the Tx/Rx status field of Tx/Rx frame descriptor is written.



## MAC Control Register

The MAC control register provides global control and status information for the MAC. The missed roll/link10 bit is a status bit. All other bits are MAC control bits.

MAC control register settings affect both transmission and reception. You can also control transmit and receive operations separately. To select customized operating features, you should write this register during power-up. This way, you will not need to write or read it again during normal operation.

After a reset is complete, the MAC controller clears the reset bit. Not all PHYs support full-duplex operation. (setting the MAC loopback bit overrides the full-duplex bit.) Also, some 10-Mb/s PHYs may interpret the loop10 bit to control different functions, and manipulate the link10 bit to indicate a different status condition.

**Table 7-18. MACON Register**

Registers	Offset	R/W	Description	Reset Value
MACON	0XA000	R/W	MAC control	0x00000000

**Table 7-19. MAC Control Register Description**

Bit Number	Bit Name	Description
[0]	Halt request (HaltReq)	Set this bit to stop data packet transmission and reception as soon as Tx/Rx of any current packets has been completed.
[1]	Halt immediate (HaltImm)	Set this bit to immediately stop all transmission and reception.
[2]	Software reset (Reset)	Set this bit to reset all MAC control and status register and MAC state machines.
[3]	Full-duplex (FullDup)	Set this bit to start transmission while reception is in progress.
[4]	MAC loopback (MACLoop)	Set this bit to cause transmission signals to be presented as input to the receive circuit without leaving the controller.
[5]	Reserved	Not applicable
[6]	MII-OFF	Use this bit to select the connection mode. If this bit is set to one, 10 M bits/s interface will select the 10 M bits/s endec. Otherwise, the MII will be selected.
[7]	Loop 10 Mb/s (Loop10)	If this bit is set, the Loop_10 external signal is asserted to the 10-Mb/s endec.
[9:8]	Reserved	Not applicable.
[10]	Missed roll (MissRoll)	This bit is automatically set when the missed error counter rolls over.
[11]	Reserved	Not applicable.
[12]	MDC-OFF	Clear this bit to enable the MDC clock generation for power management. If it is set to one, the MDC clock generation is disabled.
[13]	Enable missed roll (EnMissRoll)	Set this bit to generate an interrupt whenever the missed error counter rolls over.
[14]	Reserved	Not applicable
[15]	Link status 10 Mb/s (Link10)	This bit value is read as a buffered signal on the link 10 pin.
[31:16]	Reserved	Not applicable.

### CAM Control Register

The three accept bits in the CAM control register are used to override CAM rejections. To place the MAC in promiscuous mode, use CAM control register settings to accept packets with all three types of destination addresses. The three types of destination address packets are as follows:

- Station packets, which has an even first byte. For example, 00-00-00-00-00-00.
- A multicast-group, which has an odd first byte, but which is not FF-FF-FF-FF-FF-FF. For example, 01-00-00-00-00-00.
- A broadcast, defined as FF-FF-FF-FF-FF-FF.

When you enable CAM compare mode, the CAM memory reads the destination addresses to filter incoming messages. (You will recall that the CAM memory consists of 6-byte entries.) An alternative way to place the MAC in promiscuous mode is to set, in turn, to accept the them. To reject all packets, simply clear all of the bits in the CAMCON register.

**Table 7-20. CAMCON Register**

Registers	Offset	R/W	Description	Reset Value
CAMCON	0XA004	R/W	CAM control	0x00000000

**Table 7-21. CAM Control Register Description**

Bit Number	Bit Name	Description
[0]	Station accept (StationAcc)	Set this bit to accept any packet with a "unicast" station address.
[1]	Group accept (GroupAcc)	Accept any packet with a multicast-group address.
[2]	Broadcast accept (BroadAcc)	Accept any packet with a broadcast address.
[3]	Negative CAM (NegCAM)	When this bit is "0", packets the CAM recognizes are accepted and others are rejected. When "1", packets the CAM recognizes are rejected and others are accepted.
[4]	Compare enable (CompEn)	Set this bit to enable compare mode.
[31:5]	Reserved	Not applicable.

### MAC Transmit Control Register

To generate an interrupt after each packet, set the enable completion bit and all of the MAC error enable bits. Using MAC transmit control register settings, you can also selectively enable interrupts for specific conditions.

**Table 7-22. MACTXCON Register**

Registers	Offset	R/W	Description	Reset Value
MACTXCON	0XA008	R/W	Transmit control	0x00000000

**Table 7-23. MAC Transmit Control Register Description**

Bit Number	Bit Name	Description
[0]	Transmit enable (TxEn)	Set this bit to enable transmission. To stop transmission immediately, clear the transmit enable bit to "0".
[1]	Transmit halt request (TxHalt)	Set this bit to halt transmission after completing any current packet.
[2]	Suppress padding (NoPad)	Set to not generate pad bytes for packets of less than 64 bytes.
[3]	Suppress CRC (NoCRC)	Set to suppress addition of a CRC at the end of a packet.
[4]	Fast back-off (FBack)	Set this bit to use faster back-off times for testing.
[5]	No defer (NoDef)	Set to disable the defer counter. (The defer counter keeps counting until the carrier sense (CrS) bit is turned off.)
[6]	Send Pause (SdPause)	Set this bit to send a pause command or other MAC control packet. The send pause bit is automatically cleared when a complete MAC control packet has been transmitted. Writing a "0" to this register bit has no effect.
[7]	MII 10-Mb/s SQE test mode enable (SQEn)	Set this bit to enable MII 10-Mb/s SQE test mode.
[8]	Enable underrun (EnUnder)	Set this bit to generate an interrupt if the MAC transmit FIFO is empty during a transmission.
[9]	Enable deferral (EnDefer)	Set this bit to generate an interrupt if the MAC defers for MAX_DEFERRAL time: "0" = 0.32768 ms at 100 Mb/s; "1" = 3.2768 ms at 10-Mb/s.
[10]	Enable no carrier (EnNCarr)	Set this bit to generate an interrupt if a carrier sense is not detected while an entire packet is transmitted.
[11]	Enable excessive collision (EnExColl)	Set this bit to enable an interrupt if 16 collisions occur in the same packet.
[12]	Enable late collision (EnLateColl)	Set this bit to generate an interrupt if a collision occurs after 512 bit times (or 64 byte times).
[13]	Enable transmit parity (EnTxPar)	Set this bit to generate an interrupt if a parity error is detected in the MAC transmit FIFO.
[14]	Enable completion (EnComp)	Set this bit to generate an interrupt whenever the MAC transmits or discards one packet.
[31:15]	Reserved	Not applicable.

### MAC Transmit Status Register

A transmission status flag is set in the transmit status register, MACTXSTAT, whenever the corresponding event occurs. In addition, an interrupt is generated if the corresponding enable bit in the transmit control register is set. A MAC transmit FIFO parity error sets TxPar, and also clears TxEn, if the interrupt is enabled.

You can read and mask the five low-order bits as a single collision count. That is, when ExColl is "1", TxColl is "0". If TxColl is not "0", then ExColl is "0".

**Table 7-24. MACTXSTAT Register**

Registers	Offset	R/W	Description	Reset Value
MACTXSTAT	0XA00C	R/W	Transmit status	0x00000000

**Table 7-25. MAC Transmit Status Register Description**

Bit Number	Bit Name	Description
[3:0]	Transmit collision count (TxColl)	This 4-bit value is the count of collisions that occurred while successfully transmitting the packet.
[4]	Excessive collision (ExColl)	This bit is set if 16 collisions occur while transmitting the same packet. In this case, packet transmission is aborted.
[5]	Transmit deferred (TxDeferred)	This bit is set if transmission of a packet was deferred because of a delay during transmission.
[6]	Paused (Paused)	This bit is set if transmission of a packet was delayed due to a Pause being received.
[7]	Interrupt on transmit (IntTx)	This bit is set if transmission of a packet causes an interrupt condition.
[8]	Underrun (Under)	This bit is set if the MAC transmit FIFO becomes empty during a packet transmission.
[9]	Deferral (Defer)	This bit is set if the MAC defers a transfer because of MAX_DEFERRAL at 0.32768 ms for 100 Mb/s or 3.2768 ms for 10Mb/s.
[10]	No carrier (NCarr)	This bit is set if no carrier sense is detected during the transmission a packet.
[11]	Signal quality error (SQE)	According to the IEEE802.3 rule, the SQE signal reports the status of the PMA (MAU or transceiver) operation to the MAC layer. After transmission is complete and 1.6 $\mu$ s has elapsed, a collision detection signal is issued for 1.5 $\mu$ s to the MAC layer. This signal is called the SQE test signal. The MAC sets the SQE bit in the MACTXSTAT register if this signal is not reported within the IFG time of 6.4 $\mu$ s.
[12]	Late collision (LateColl)	This bit is set if a collision occurs after 512 bit times (or 64 byte times).
[13]	Transmit parity error (TxPar)	This bit is set if a collision occurs after 512 bit times (or 64 byte times).
[14]	Completion (Comp)	This bit is set when the MAC transmits, or discards, one packet.
[15]	Transmission halted (TxHalted)	Transmission was halted by clearing the TxEn bit or the halt immediate (HaltImm) bit.
[31:16]	Reserved	Not applicable.

### MAC Receive Control Register

To issue an interrupt after each packet is received, set the enable good bit and all of the error enable bits in the MACRXCON register. You can also enable interrupts for specific conditions. Standard packet length values do not include a preamble or a start frame delimiter (SFD).

**Table 7-26. MACRXCON Register**

Registers	Offset	R/W	Description	Reset Value
MACRXCON	0XA010	R/W	Receive control	0x00000000

**Table 7-27. MAC Receive Control Register Description**

Bit Number	Bit Name	Description
[0]	Receive enable (RxEn)	Set this bit to "1" to enable MAC receive operation. If "0", stop reception immediately.
[1]	Receive halt request (RxHalt)	Set this bit to halt reception after completing the reception of any current packet.
[2]	Long enable (LongEn)	Set this bit to receive frames with lengths greater than 1518 bytes.
[3]	Short enable (ShortEn)	Set this bit to receive frames with lengths less than 64 bytes.
[4]	Strip CRC value (StripCRC)	Set this bit to check the CRC, and then strip it from the message.
[5]	Pass control packet (PassCtl)	Set this bit to enable the passing of control packets to a MAC client.
[6]	Ignore CRC value (IgnoreCRC)	Set this bit to disable CRC value checking.
[7]	Reserved	Not applicable.
[8]	Enable alignment (EnAlign)	Set this bit to enable the alignment interrupt. An alignment interrupt occurs when a packet is received whose length (in bits) is not a multiple of eight, and whose CRC is invalid.
[9]	Enable CRC error (EnCRCErr)	Set this bit to enable the CRC interrupt. A CRC interrupt occurs when a packet is received whose CRC is invalid or if, during its reception, the PHY asserts Rx_er.
[10]	Enable overflow (EnOver)	Set this bit to enable the overflow interrupt. An overflow interrupt is generated when a packet is received and the MAC receive FIFO is full.
[11]	Enable long error (EnLongErr)	Set this bit to enable the long error interrupt. A long error interrupt is generated when a frame longer than 1518 bytes is received (unless the long enable bit is set).
[12]	Reserved	Not applicable.
[13]	Enable receive parity (EnRxPar)	Set this bit to enable a receive parity interrupt if the MAC receive FIFO detects a parity error.
[14]	Enable Good (EnGood)	Set this bit to enable the good (packet) interrupt upon error-free reception of a complete data packet.
[31:15]	Reserved	Not applicable.

**NOTE:** The frame lengths given above do not include preamble and start frame delimiter (SFD).

**MAC Receive Status Register**

A receive status flag is set in the MAC receive status register, MACRXSTAT, whenever the corresponding event occurs. When a status flag is set, it remains set until another packet arrives, or until software writes a "1" to the flag to clear the status bit. If the corresponding interrupt enable bit in the receive control register is set, an interrupt is generated whenever a status flag is set. A MAC receive parity error sets RxPar, and also clears the RxEn bit (if an interrupt is enabled).

**Table 7-28. MACRXSTAT Register**

Registers	Offset	R/W	Description	Reset Value
MACRXSTAT	0XA014	R/W	Receive status	0x00000000

**Table 7-29. MAC Receive Status Register Description**

Bit Number	Bit Name	Description
[4:0]	Reserved	Not applicable.
[5]	Control frame received (CtlRecd)	This bit is set if the packet received is a MAC control frame (type = 8808H), if the CAM recognizes the packet address, and if the frame length is 64 bytes.
[6]	Interrupt on receive (IntRx)	This bit is set if the reception of a packet caused an interrupt to be generated. This includes a good received interrupt, if the EnGood bit is set.
[7]	Receive 10-Mb/s status (Rx10Stat)	This bit is set to "1" if a packet was received over the 7-wire interface or to "0" if a packet was received over the MII.
[8]	Alignment error (AlignErr)	This bit is set if the frame length in bits was not a multiple of eight and the CRC was invalid.
[9]	CRC error (CRCErr)	This bit is set if the CRC at the end of a packet did not match the computed value, or else the PHY asserted Rx_er during packet reception.
[10]	Overflow error (overflow)	This bit is set if the MAC receive FIFO was full when it needed to store a received byte.
[11]	Long error (LongErr)	This bit is set if the MAC received a frame longer than 1518 bytes. (It is not set if the long enable bit in the receive control register, MACRXCON, is set.)
[12]	Reserved	Not applicable.
[13]	Receive parity error (RxPar)	This bit is set if a parity error is detected in the MAC receive FIFO.
[14]	Good received (Good)	This bit is set if a packet was successfully received with no errors. If EnGood = "1", an interrupt is also generated.
[15]	Reception halted (RxHalted)	This bit is set if reception was halted by clearing RxEn or by setting the HaltImm bit in the MAC control register, MACON.
[31:16]	Reserved	Not applicable.

**MAC Station Management Data Register****Table 7-30. STADATA Register**

Registers	Offset	R/W	Description	Reset Value
STADATA	0XA018	R/W	Station management data	0x00000000

**Table 7-31. Station Management Register Description**

Bit Number	Bit Name	Description
[15:0]	Station management data.	This register contains a 16-bit data value for the station management function.

**MAC Station Management Data Control and Address Register**

The MAC controller provides support for reading and writing station management data to the PHY. Setting options in station management registers does not affect the controller. Some PHYs may not support the option to suppress preambles after the first operation.

**Table 7-32. STACON Register**

Registers	Offset	R/W	Description	Reset Value
STACON	0XA01C	R/W	Station management control and address	0x00008000

**Table 7-33. STACON Register Description**

Bit Number	Bit Name	Description
[4:0]	PHY register address (Addr)	A 5-bit address, contained in the PHY, of the register to be read or written.
[9:5]	PHY address (PHY)	The 5-bit address of the PHY device to be read or written.
[10]	Write (Wr)	To initiate a write operation, set this bit to "1". For a read operation, clear it to "0".
[11]	Busy bit (Busy)	To start a read or write operation, set this bit to "1". The MAC controller clears the Busy bit automatically when the operation is completed.
[12]	Preamble suppress (PreSup)	If you set this bit, the preamble is not sent to the PHY. If it is clear, the preamble is sent.
[15:13]	MDC clock rating	Control the MDC period. MD_CA[15:13]      MDC period 000                16 × (1/fMCLK) 001                18 × (1/fMCLK) 010                20 × (1/fMCLK) .                    . .                    . 111                30 × (1/fMCLK) MDC period = MD_CA[15:13] × 2 + 16 Default MD_CA[15:13] = 100
[31:16]	Reserved	Not applicable.



### CAM Enable Register

The CAM enable register, CAMEN, indicates which CAM entries are valid, using a direct comparison mode. Up to 21 entries, numbered 0 through 20, may be active, depending on the CAM size. If the CAM is smaller than 21 entries, the higher bits are ignored.

**Table 7-34. CAMEN Register**

Registers	Offset	R/W	Description	Reset Value
CAMEN	0XA028	R/W	CAM enable	0x00000000

**Table 7-35. CAM Enable Register Description**

Bit Number	Bit Name	Description
[20:0]	CAM enable (CAMEn)	Set the bits in this 21-bit value to selectively enable CAM locations 20 through 0. To disable a CAM location, clear the appropriate bit.
[31:21]	Reserved	Not applicable.

### MAC Missed Error Count Register

The value in the missed error count register, EMISSCNT, indicates the number of packets that were discarded due to various type of errors. Together with status information on packets transmitted and received, the missed error count register and the two pause count registers provide the information required for station management.

Reading the missed error counter register clears the register. It is then the responsibility of software to maintain a global count with more bits of precision.

The counter rolls over from 0x7FFF to 0x8000 and sets the corresponding bit in the MAC control register. It also generates an interrupt if the corresponding interrupt enable bit is set. If station management software wants more frequent interrupts, you can set the missed error count register to a value closer to the rollover value of 0x7FFF. For example, setting a register to 0x7F00 would generate an interrupt when the count value reaches 256 occurrences.

**Table 7-36. EMISSCNT Register**

Registers	Offset	R/W	Description	Reset Value
EMISSCNT	0XA03C	R(Clr)/W	Missed error count	0x00000000

**Table 7-37. Missed Error Count Register Description**

Bit Number	Bit Name	Description
[15:0]	Alignment error count (AlignErrCnt)	The number of packets received with alignment errors. This software counter increments at the end of a packet reception if the Rx_Stat value indicates an alignment error.
	CRC error count (CRCErrCnt)	The number of packets received with a CRC error. This software counter increments if the Rx_Stat value indicates a CRC error. If the Rx_Stat value indicates another type of error, such as an alignment error, this counter is not incremented.
	Missed error count (MissErrCnt)	The number of valid packets rejected by the MAC unit because of MAC receive FIFO overflows, parity errors, or because the Rx_En bit was cleared. This count does not include the number of packets rejected by the CAM.
[31:16]	Reserved	Not applicable.

**MAC Received Pause Count Register**

The received pause count register, EPZCNT, stores the current value of the 16-bit received pause counter.

**Table 7-38. EPZCNT Register**

Registers	Offset	R/W	Description	Reset Value
EPZCNT	0XA040	R	Pause count	0x00000000

**Table 7-39. Received Pause Count Register Description**

Bit Number	Bit Name	Description
[15:0]	Received pause count (EPZCNT)	The count value indicates the number of time slots the transmitter was paused due to the receipt of control pause operation packets from the MAC.

**MAC Remote Pause Count Register**

The remote Pause count register, ERMPZCNT, stores the current value of the 16-bit remote Pause counter.

**Table 7-40. ERMPZCNT Register**

Registers	Offset	R/W	Description	Reset Value
ERMPZCNT	0XA044	R	Remote pause count	0x00000000

**Table 7-41. Remote Pause Count Register Description**

Bit Number	Bit Name	Description
[15:0]	Received pause count (EPZCNT)	The count value indicates the number of time slots that a remote MAC was paused as a result of its sending control pause operation packets.

**MAC Transmit Control Frame Status**

The transmit control frame status register, ETXSTAT, is a RAM-based register which provides the status of a MAC control packet as it is sent to a remote station. This operation is controlled by the SdPause bit in the transmit control register, MACTXCON.

It is the responsibility of the DMA engine to read this register, and to generate an interrupt to notify the system that the transmission of a MAC control packet has been completed.

**Table 7-42. ETXSTAT Register**

Registers	Offset	R/W	Description	Reset Value
ETXSTAT	0X9040	R	Transmit control frame status	0x00000000

**Table 7-43. Transmit Control Frame Register Description**

Bit Number	Bit Name	Description
[15:0]	Tx_Stat value	A 16-bit value indicating the status of a MAC control packet as it is sent to a remote station. Read by the DMA engine.

## ETHERNET CONTROLLER OPERATIONS

This section contains additional details about the following operations of the S3C4510B ethernet controller:

- MAC frame and packet formats
- Transmitting a frame
- Receiving a frame
- Full-duplex pause operation
- Error signalling and network management

### MAC Frame and Packet Formats

The MAC transmits each byte of all fields, except the FCS, least-significant bit first. In this document, the term "packet" is used to denote all of the bytes that are transmitted and received, while "frame" refers only to the bytes delivered by the station for transmission, and to the station who is receiving.

Table 7-44 lists the eight fields in a standard data packet (IEEE 802.3/Ethernet frame). See also Figure 7-13.

**Table 7-44. MAC Frame and Package Format Description**

Field Name	Field Size	Description
Preamble	7 bytes	The bits in each preamble byte are 10101010, transmitted from left to right.
Start frame delimiter (SFD)	1 byte	The SFD bits are 10101011, transmitted from left to right.
Destination address	6 bytes	The destination address can be an individual address or a multicast (or broadcast) address.
Source address	6 bytes	The MAC does not interpret the source address bytes. However, to qualify as a valid station address, the first bit transmitted (the LSB of the first byte) must be a "0".
Length or type	2 bytes	The MAC treats length fields greater than 1500 bytes as type fields. Byte values less than or equal to 1500 indicate the number of logical link control (LLC) data bytes in the data field. The MAC transmits the high-order byte first.
Logical link control (LLC) data	46 to 1500 bytes	Data bytes used for logical link control.
PAD	0 to 46 bytes	If the LLC data is less than 46 bytes long, the MAC transmits pad bytes of all zeros.
Frame check sequence (FCS)	4 bytes	The FCS field contains a 16-bit error detection code that is computed as a function of all fields except the preamble, the SFD, and the FCS itself. The FCS - 32 polynomial function is as follows: " $X^{32} + X^{26} + X^{23} + X^{16} + X^{12} + X^{11} + X^{10} + X^8 + X^7 + X^5 + X^4 + X^2 + X + 1$ ".



### Destination Address Format

Bit 0 of the destination address is an address type designation bit. It identifies the address as either an individual or a group address. Group addresses are sometimes called "multicast" addresses and individual addresses are called "unicast" addresses. The broadcast address is a special group address in the special hex format: FF-FF-FF-FF-FF-FF.

Bit 1 of the destination address distinguishes between locally or globally administered addresses. For globally administered or universal (U) addresses, the bit value is "0". If an address is to be assigned locally, you must set this bit to "1". For the broadcast address, this bit must also be set to "1".

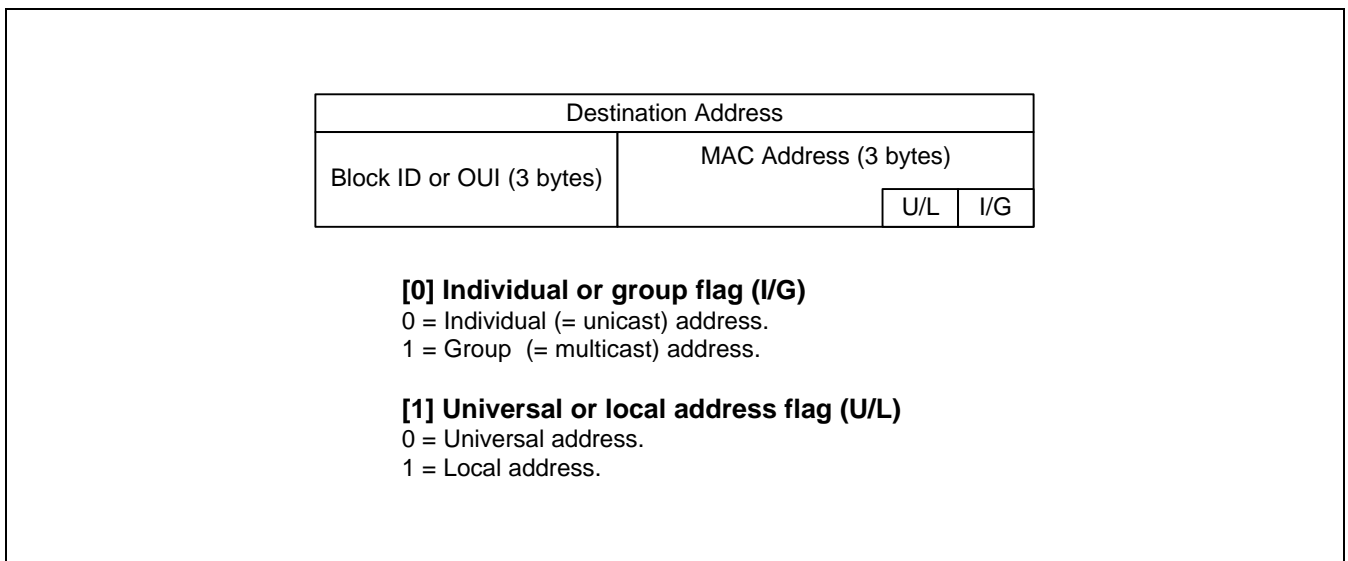

**Figure 7-16. Destination Address Format**

### Special Flow Control Destination Address

The current specification for full-duplex flow control specifies a special destination address for the Pause operation packet. In order for the MAC to receive packets which contain this special destination address, the address must be programmed in one of the CAM entries. This CAM entry must then be enabled, and the CAM activated.

Some CAM entries are also used when generating a flow control packet using the SdPause bit in the MAC transmit control register.

## TRANSMITTING A FRAME

To transmit a frame, the transmit enable bit in the transmit control register must be set and the transmit halt request bit must be zero. In addition, the halt immediate and halt request bits in the MAC control register must be "0". These conditions are normally set after any BDMA controller initialization has occurred. The system then uses the Tx\_wr# and Tx\_EOF signals to transfer bytes to the transmit data buffer.

The transmit state machine starts transmitting the data in the FIFO, and will retain the first 64 bytes until after this station has acquired the net. At that time, the transmit block requests more data and transmits it until the system asserts the Tx\_EOF input, signaling the end of data to be transmitted. The transmit block appends the calculated CRC to the end of the packet, and transmission ends. It then sets the transmit status register bit 0, signaling a successful transmission. This action may cause an interrupt, if enabled.

A frame transmit operation can be subdivided into two operations, 1) a MII interface operation, and 2) a BDMA/ MAC interface operation.

### BDI TRANSMIT OPERATION

The BDI transmit operation is a simple FIFO mechanism. The BDMA engine stores data to be transmitted, and the transmit state machine empties it when the MAC successfully acquires the net.

Note that the two time domains intersect at the FIFO controller. The writing and reading of data is asynchronous and on different clocks. Reading is driven by either a 25-MHz or a 2.5-MHz transmit clock. Writing is driven by the synchronous Sys\_clk, which is asynchronous to Tx\_clk.

After a reset, the transmit FIFO is empty. The transmit block asserts the Tx\_rdy signal, and transmission is disabled. To enable transmission, the system must set the transmit enable bit in the transmit control register. In addition, eight bytes of data must be present in the transmit FIFO. The BDMA engine can start stuffing data into the FIFO, and then enable the transmit bit. (Or it can enable the transmit bit first and then start stuffing data into the FIFO.) The transmit operation can only start if both of these conditions are met.



### BDI Transmit Timing

When the transmit block asserts the Tx\_rdy signal, the BDMA engine can write data into the transmit FIFO by asserting the Tx\_wr# signal. Figure 7-15 shows timing sequences for back-to-back transfers and transfers with wait states. This is a synchronous interface, which means that data is latched in at the rising edge of the Sys\_clk when Tx\_wr# is asserted. For slower interfaces, the rising edge of Tx\_wr# can be delayed.

This is the equivalent of asserting a wait state in a synchronous operation. The transmit FIFO machine checks the Tx\_par and the Tx\_EOF bits. If there is a parity error, the transmit block aborts the transmission, resets the FIFO, and generates an interrupt by setting the TxPar bit in the transmit status register.

The Tx\_EOF bit signals the end of one frame to be transmitted. When it detects this bit, the transmit block de-asserts Tx\_rdy until it has transmitted the packet. It then re-asserts Tx\_rdy when the BDMA can transfer the next packet into the MAC FIFO.

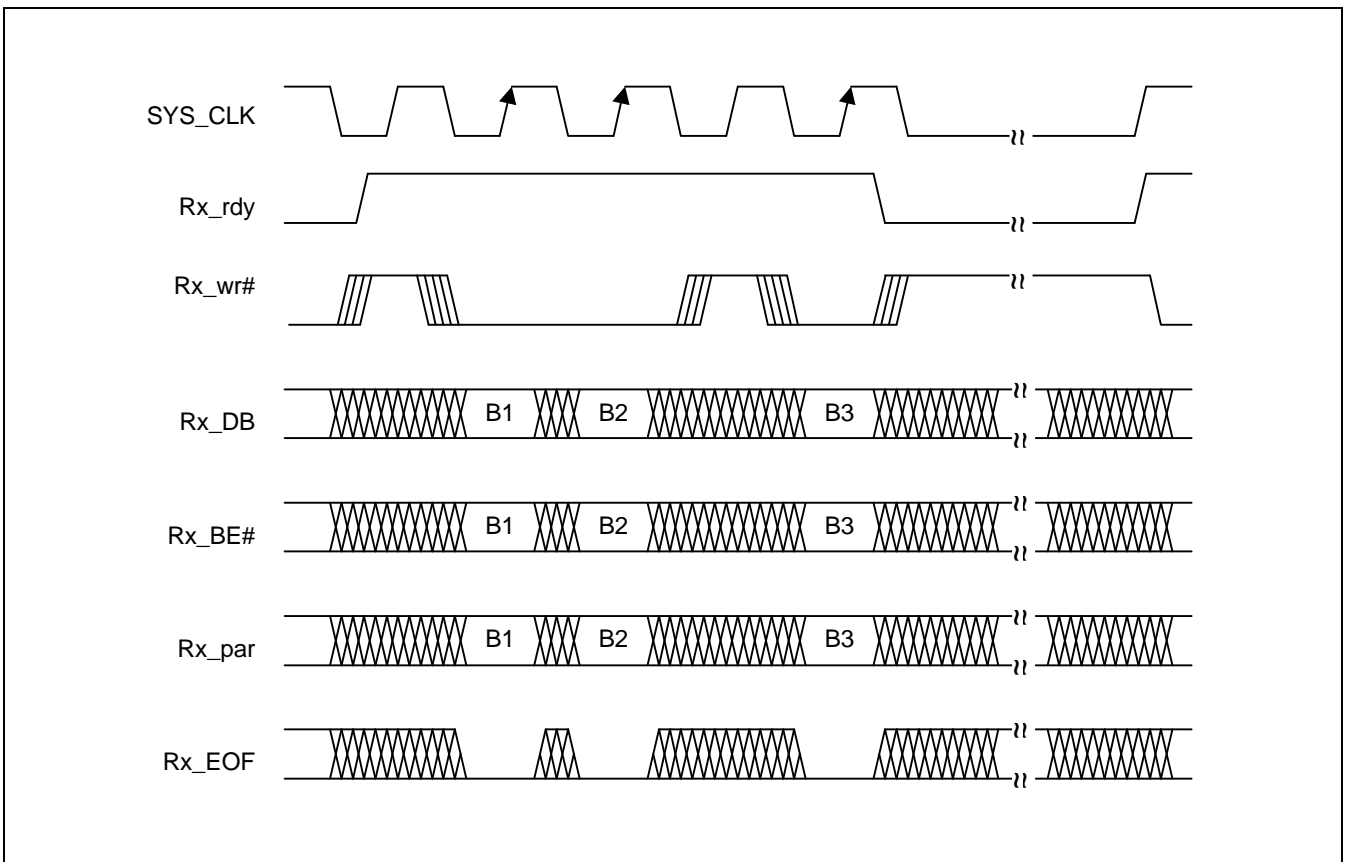

Figure 7-17. BDI Transmit Data Timing

**MII TRANSMIT OPERATION**

The transmit block consists of three state machines: the gap\_ok state machine, the back\_off state machine, and the main transmit state machine.

**The gap\_ok State Machine**

The gap\_ok state machine tracks and counts the inter-gap timing between the frames. When not operating in full-duplex mode, it counts 96 bit times from the deassertion of the carrier sense (CrS) signal. If there is any traffic within the first 64 bit times, the gap\_ok state machine reset itself and starts counting from zero.

If there is any traffic in the last 1/3 of the inter-frame gap, the gap\_ok state machine continues counting. Following a successful transmission, a gap\_ok is sent at the end of the next 96 bit times, regardless of the network traffic.

In full-duplex mode, the gap\_ok state machine starts counting at the end of the transmission and the gap\_ok signal is sent at the end of the 96 bit times, regardless of the network traffic.

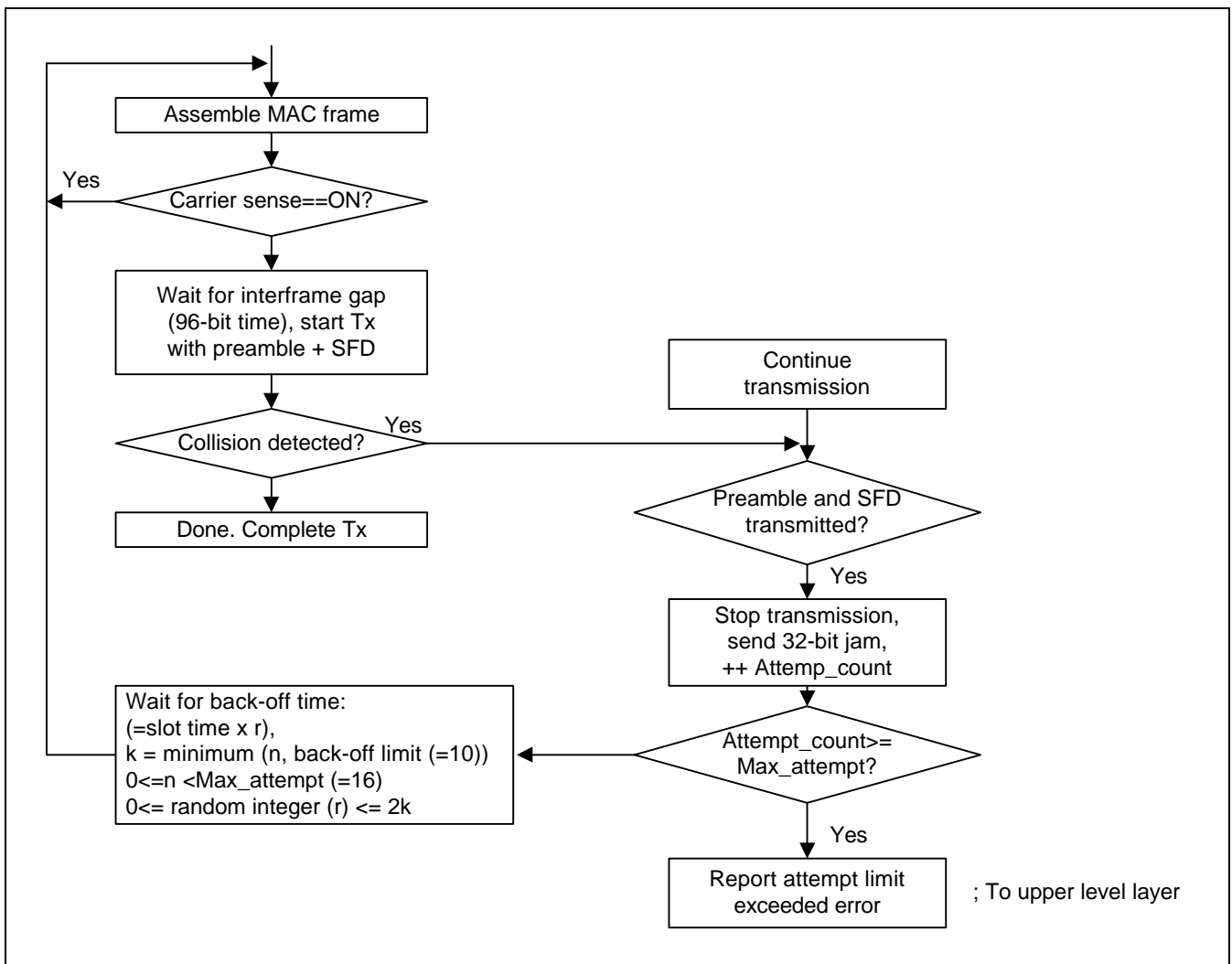

Figure 7-18. CSMA/CD Transmit Operation

### The back\_off State Machine

The back\_off state machine implements the back-off and retry algorithm of the 802.3 CSMA/CD. When a collision is detected, the main transmit state machine starts the back\_off state machine's counters and waits for the back-off time (including zero) to elapse. This time is a multiple of 512 bit times that elapse before the packet that caused the collision is re-transmitted.

Each time there is a collision (for one single packet), the back\_off state machine increments an internal retry attempt counter. A 11-bit pseudo random number generator outputs a random number by selecting a subset of the value of the generator at any time. The subset is incremented by one bit for each subsequent attempt. This implementation is represented by the following equation:

$$0 \leq \text{random integer}(r) < 2^K$$

$$K = \min(n, \text{backoff limit} (= 10))$$

where "r" is the number of slot times the MAC must wait in case of a collision, and "n" is the number of retry attempts.

For example, after the first collision, "n" is 1 and "r" is a random number between 0 and 1. The pseudo random generator in this case is one-bit wide and gives a random number of either 0 or 1. After the second attempt, "r" is a random number between 0 and 3. Therefore, the state machine looks at the two least-significant bits of the random generator (n = 2), which gives a value between 0 and 3.

### The Main Transmit State Machine

The main transmit state machine implements the remaining MAC layer protocols. If there is data to be transferred, if the inter-frame gap is valid, and if the MII is ready (that is, if there are no collisions and no CRS in full-duplex mode), the transmit block then transmits the preamble followed by the SFD.

After the SFD and preamble are transmitted, the block transmits 64 bytes of the data, regardless of the packet length, unless short transmission is enabled. This means that if the packet is less than 64 bytes, it will pad the LLC data field with zeros. It will also append the CRC to the end of the packet, if CRC generation is enabled.

If there is any collision during this first 72 bytes (8 bytes of preamble and SFD, and 64 bytes of the frame), the main transmit state machine stops the transmission and transmits a jam pattern (32 bits of 1's). It then increments the collision attempt counter, returns control to the back\_off state machine, and re-transmits the packet when the back-off time has elapsed and the gap time is valid.

If there are no collisions, the transmit block transmits the rest of the packet. At this time (that is, after the first 60 bytes have been transmitted without collisions), the main transmit state machine lets the BDMA engine overwrite the packet. After it transmits the first 64 bytes, the transmit block transmits the rest of the packet, appending the CRC to the end. parity errors, FIFO errors, or more than 16 collisions will cause the transmit state machine to abort the packet (no retry) and queue up the next packet.

In case of any transmission errors, the transmit block sets the appropriate error bit in the transmit status register. It may also generate an interrupt, depending on the enable bit settings in the transmit control register.

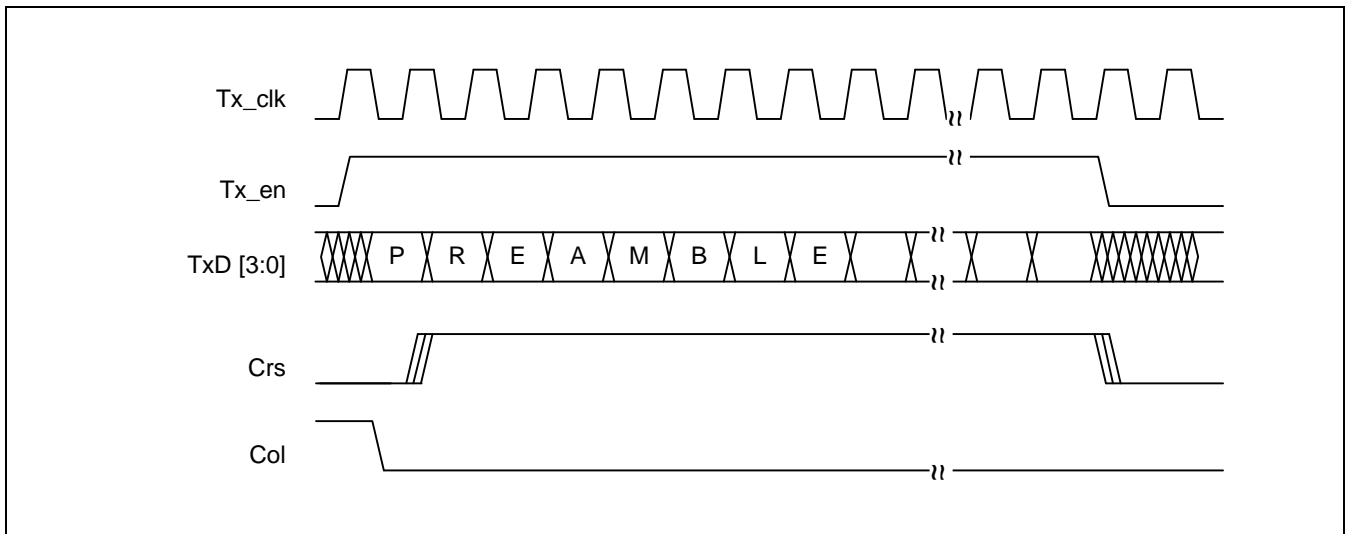

Figure 7-19. Timing for Transmit without Collision

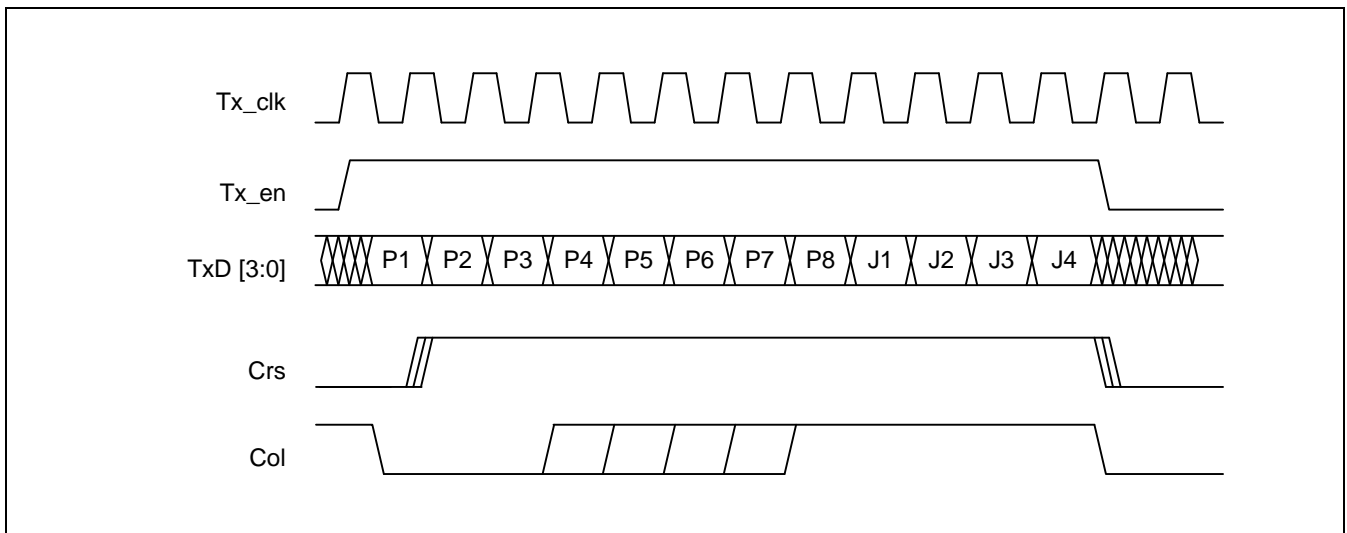

Figure 7-20. Timing for Transmit with Collision in Preamble

## RECEIVING A FRAME

The receive block, when enabled, constantly monitors a data stream coming either from the MII or, if in loop-back mode, from the transmit block. The MII supplies from zero to seven bytes of preamble, followed by the start frame delimiter (SFD). The receive block checks that the first nibbles received are preamble, and then looks for the SFD (10101011) in the first eight bytes. If it does not detect the SFD by then, it treats the packet as a fragment and discards it.

The first nibble of destination address follows the SFD, least-significant bits first. When it has received a byte, the receive block generates parity, stores the byte with its parity in the receive FIFO, and asserts `Rx_rdy`. It combines subsequent nibbles into bytes and stores them in the FIFO.

### BDI RECEIVE DATA TIMING

When the system asserts `Rx_rd#`, the receive block reads the first byte from the FIFO, checks parity, and drives the byte on `Rx_DB`, and the byte's parity on `Rx_par`. If the FIFO is now empty, it drops `Rx_rdy`. When it drives out the last byte of a packet, it asserts `Rx_EOF`.

Figure 7-19 shows the timing sequence for transmitting bytes back-to-back, transmitting with wait states, and transmitting the last byte.

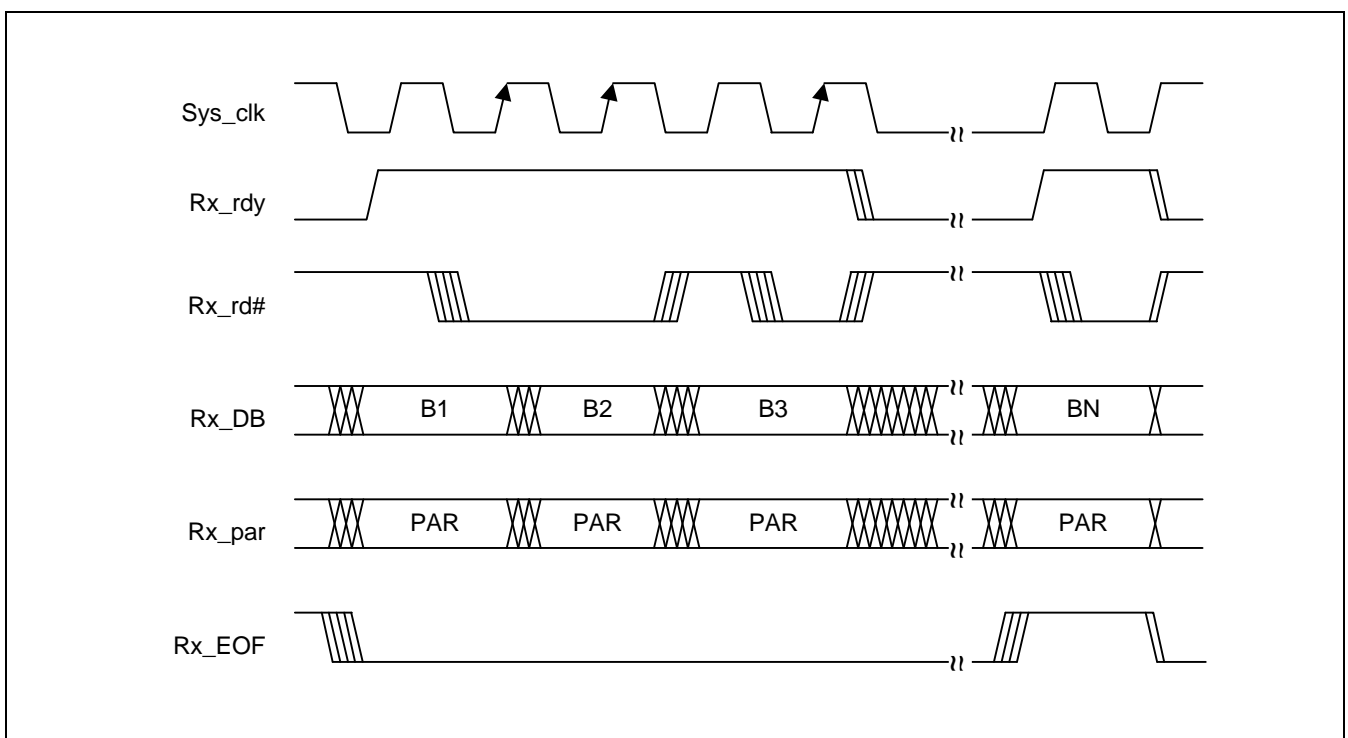

Figure 7-21. BDI Receive Data Timing

**RECEIVE FRAME TIMING WITH/WITHOUT ERROR**

If, during frame reception, both Rx\_DV and Rx\_er are asserted, a CRC error is reported for the current packet.

As each nibble of the destination address is received, the CAM block attempts to recognize it. After receiving the last destination address nibble, if the CAM block rejects the packet, the receive block asserts the Rx\_toss signal, and discards any bytes not yet removed from the receive FIFO that came from the current packet. If this operation leaves the FIFO empty, it drops Rx\_rdy.

Figure 7-20 shows the MII receive data timing without error. The RX\_DV signal, which entered the MII from the PCS layer, will be ON when the PCS layer recovers the Rx\_clk from the receive bit stream and delivers the nibble data on RxD[3:0] data line. The RX\_DV signal must be ON before the starting frame delimiter(SFD) is received. When the Rx\_DV signal is ON, the preamble and SFD parts of the frame header are delivered to MII, synchronized with the 25-MHz Rx\_clk. (The carrier sense (CrS) signal was turned on during receive frame.)

As its response to the Rx\_er signal, the MII immediately inserts an alternative data bit stream into the receive data stream. As a result, the MAC discards this received error frame using the FCS.

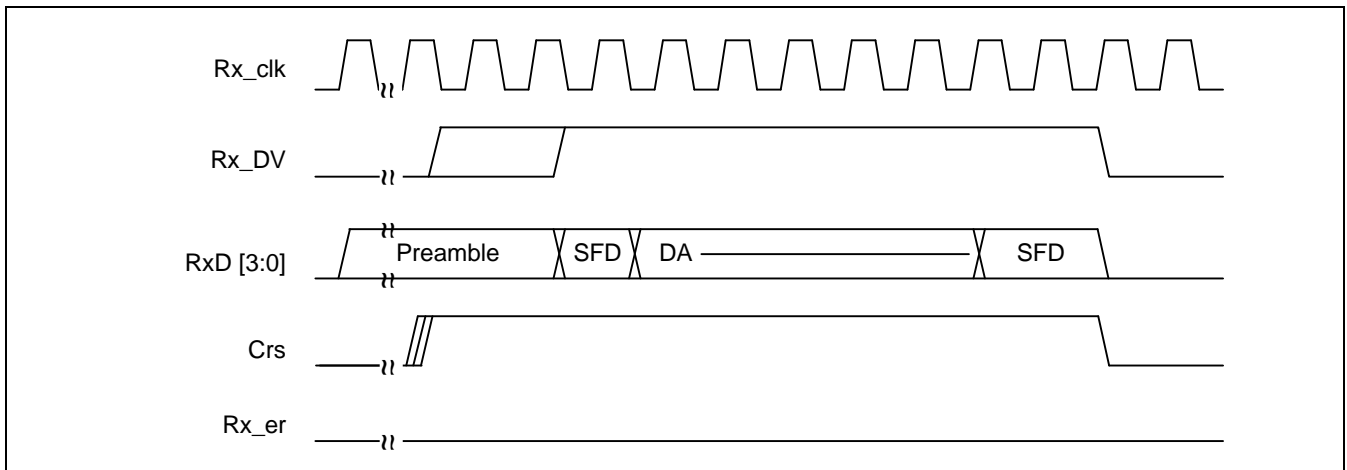

**Figure 7-22. Receiving Frame without Error**

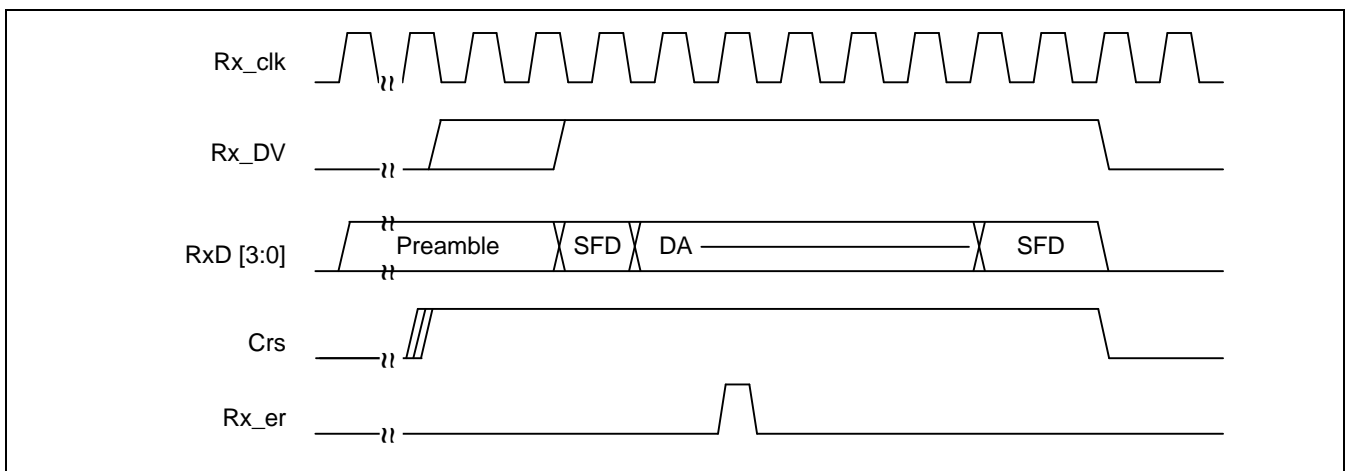

**Figure 7-23. Receiving Frame with Error**

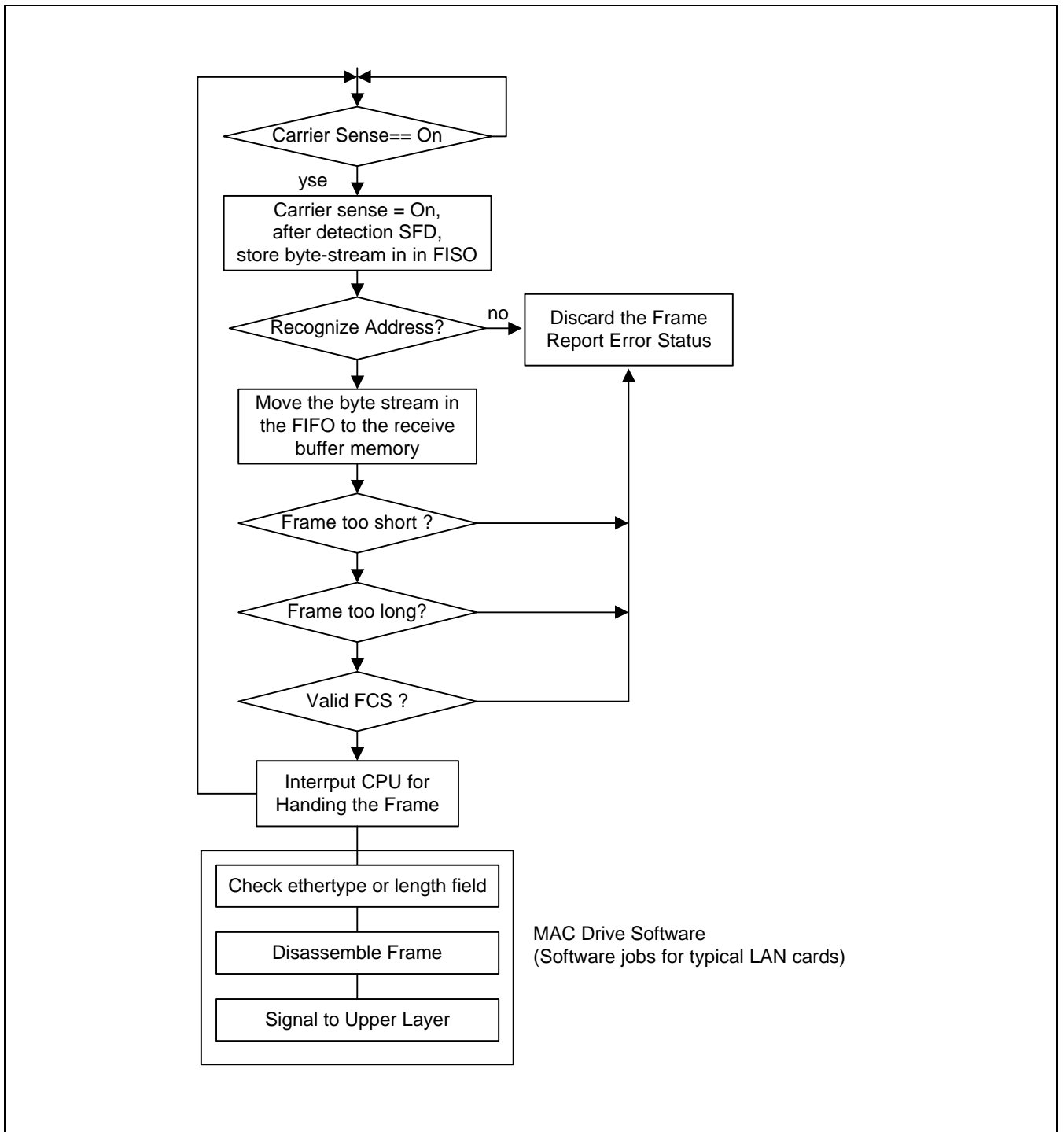

Figure 7-24. CSMA/CD Receive Operation

## THE MII STATION MANAGER

The MDIO (management data input/output) signal line is the transmit and receive path for control/status information for the station management entity, STA. The STA controls and reads the current operating status of the PHY layer. The speed of transmit and receive operations is determined by the management data clock, MDC.

The frame structure of the STA which writes command to control registers, or which reads the status register of a PHY device, is shown Table 7-45. The PHY address is defined as the identification (ID) value of the various PHY devices that may be connected to a single MAC. Register addresses can contain the ID value for up to 32 types of PHY registers.

Turn-around bits are used to regulate the turn-around time of the transmit/receive direction between the STA and a PHY device. So that the STA can read the set value of a PHY device register, it must transmit the frame data, up to a specific register address, to the PHY device. During the write time (which is an undirected transmission), the STA transmits a stream of turn-around bits. As a result, by transmitting a write or read message to a PHY device through the MDIO, the STA can issue a request to set the operation or to read the operation status.

As its response this message, the PHY device resets itself, sets loop-back mode, selects active/non-active auto-negotiation process, separates the PHY and MII electrically, and determines whether or not to activate the collision detection process.

When it receives a read command, the PHY reports the kind of PHY device it is, such as 100Base-T4, FDX 100base-X, HDX 100Base-X, 10-Mb/s FDX, or 10-Mb/s HDX.

**Table 7-45. STA Frame Structure Description**

	Preamble	Start of Frame	Operation Code	PHY Address	Register Address	Turnaround	Data	Idle
Write (Command)	11111111 (32 bits)	01	01 (write)	5 bits	5 bits	10 (2 bits)	16 bits (register value)	Z
Read (Status)	11111111 (32 bits)	01	10 (read)	5 bits	5 bits	Z0	16 bits (register value)	Z
Direction: STA to PHY						Direction: PHY to STA		



## FULL-DUPLEX PAUSE OPERATIONS

### Transmit Pause Operation

To enable a full-duplex Pause operation, the special broadcast address for MAC control packets must be programmed into the CAM, and the corresponding CAM enable bit set. The special broadcast address can be a CAM location. To optimize the utilization CAM entries, you can specify a preference for specific CAM locations. This feature is described below.

The MAC receive circuit recognizes a full-duplex Pause operation when the following conditions are met:

- The type/length field has the special value for MAC Control packets, 0x8808.
- The packet is recognized by the CAM.
- The length of the packet is 64 bytes.
- The operation field specifies a Pause operation.

When a full-duplex pause operation is recognized, the MAC receive circuit loads the operand value into the pause count register. It then signals both the MAC and the BDMA engine that the pause should begin at the end of the current packet, if any.

The pause circuit maintains the pause counter, and decrements it to zero. It does this before it signals the end of the pause operation, and before allowing the transmit circuit to resume its operation.

If a second full-duplex pause operation is recognized while the first operation is in effect, the pause counter is reset with the current operand value. Note that a count value of zero may cause pre-mature termination of a pause operation that is already in progress.

### Remote Pause Operation

To send a remote pause operation, following these steps:

1. Program CAM location 0 with the destination address.
2. Program CAM location 1 with the source address.
3. Program CAM location 18 with length/type field, opcode, and operand.
4. Program the 2 bytes that follow the operand with 0000H.
5. Program the three double words that follow CAM location 18 with zeros.
6. Write the transmit control register to set the SdPause bit.

The destination address and source address are commonly used as the special broadcast address for MAC control frames and the local station address, respectively. To support future uses of MAC control frames, these values are fully programmable in the flow control 100-/10-Mbit/s Ethernet MAC.

When the remote Pause operation is completion, the transmit status is written to the transmit control frame status register. The BDMA engine is responsible for providing an interrupt enable control.

## Error Signalling

The error/abnormal operation flags asserted by the MAC are arranged into transmit and receive groups. These flag groups are located either in the transmit status register (Tx\_stat) or the receive status register (Rx\_stat). A missed packet error counter is included for system network management purposes.

Normally, software does not have enough direct control to examine the status registers directly. Therefore, the BDMA engine must store the values in system memory so that they can be examined there by software.

## Reporting of Transmission Errors

A transmit operation terminates when the entire packet (preamble, SFD, data, and CRC) has been successfully transmitted through the MII without a collision. In addition, the transmit block detects and reports both internal and network errors.

Under the following conditions, the transmit operation will be aborted (in most cases).

Parity error	The 8 bits of data coming in through the BDII has an optional parity bit. A parity bit also protects each byte in the MAC transmit FIFO. If a parity error occurs, it is reported to the transmit state machine, and the transmission is aborted. A detected parity error sets the TxPar bit in the transmit status register.
Transmit FIFO underrun	The 80-byte transmit FIFO can handle a system latency of 6.4bi (640 bit times). An underrun of the transmit FIFO during transmission indicates a system problem (namely, that the system cannot keep up with the demands of the MAC), and the transmission is aborted.
No CRS	The carrier sense signal (CrS) is monitored from the beginning of the start of frame delimiter (SFD) to the last byte transmitted. A "No CrS" indicates that CrS was never present during transmission (a possible network problem), but the transmission will NOT be aborted. Note that during loop-back mode, the MAC is disconnected from the network, and a "No CRC" will not be detected.
Excessive collision error	Whenever the MAC encounters a collision during transmit, it will back off, update the "attempt counter," and retry the transmission later on. When the attempt counter reaches 16 (16 attempts that all resulted in a collision), the transmission is aborted. This indicates a network problem.
Late collision error	(Transmit out of window collision) Normally, the MAC would detect a collision (if one occurs) within the first 64 bytes of data that are transmitted, including the preamble and SFD. If a collision occurs after this time frame, a possible network problem is indicated. The error is reported to the transmit state machine, but the transmission is NOT aborted. Instead, it performs a back-off, as usual.
Excessive deferral error	During its first attempt to send a packet, the MAC may have to defer the transmission because the network is busy. If this deferral time is longer than 32K bit times, the transmission is aborted. Excessive deferral errors indicate a possible network problem.

## Reporting of Receive Errors

When it detects a start of frame delimiter (SFD), the receive state machine starts putting data it has received from the MII into the receive FIFO. It also checks for internal errors (FIFO overruns) while reception is in progress.

When the receive operation is completed, the receive state machine checks for external errors, such as frame alignment, length, CRC, and frame too long.

The following is a description of the types of errors that may occur during a receive operation:

Priority error	A parity bit protects each byte in the MAC receive FIFO. If a parity error occurs, it is reported to the receive state machine. A detected parity error sets the RxPar bit in the receive status register.
Frame Alignment Error	(Dribble) After receiving a packet, the receive block checks that the incoming packet (including CRC) was correctly framed on an 8-bit boundary. If it is not and if the CRC is invalid, data has been disrupted through the network, and the receive block reports a frame alignment error. A CRC error is also reported.
CRC Error	After receiving a packet, the receive block checks the CRC for validity, and reports a CRC error if it is invalid. The receive unit can detect network-related errors such as CRC, frame alignment, and length errors. It can also detect these types of errors in the following combinations: <ul style="list-style-type: none"><li>— CRC errors only</li><li>— Frame alignment and CRC errors only</li><li>— Length and CRC errors only</li><li>— Frame alignment, length, and CRC errors</li></ul>
Frame too long	The receive block checks the length of the incoming packet at the end of reception (including CRC, but excluding preamble and SFD). If the length is longer than the maximum frame size of 1518 bytes, the receive block reports receiving a "long packet", unless long frame mode is enabled.
Receive FIFO overrun	During reception, the incoming data are put into the receive FIFO temporarily before they are transferred to the system memory. If the FIFO is filled up because of excessive system latency or for other reasons, the receive block sets the overrun bit in the receive status register.
MII error	The PHY informs the MAC if it detects a medium error (such as a coding violation) by asserting the input pin Rx_er. When the MAC sees Rx_er asserted, it sets CRCErr bit of the receive status register.

**Timing Parameters for MII Transactions**

The timing diagrams in this section conform to the guidelines described in the "Draft Supplement to ANSI/IEEE Std. 802.3, Section 22.3, Signal Characteristics."

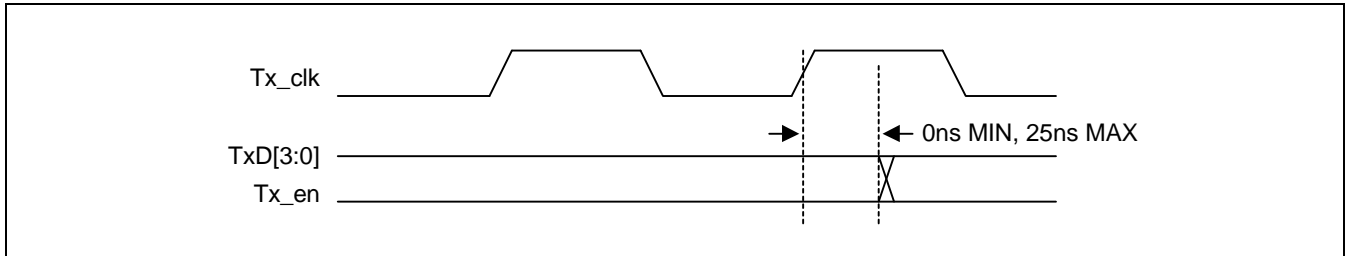

**Figure 7-25. Transmit Signal Timing Relationship at MII**

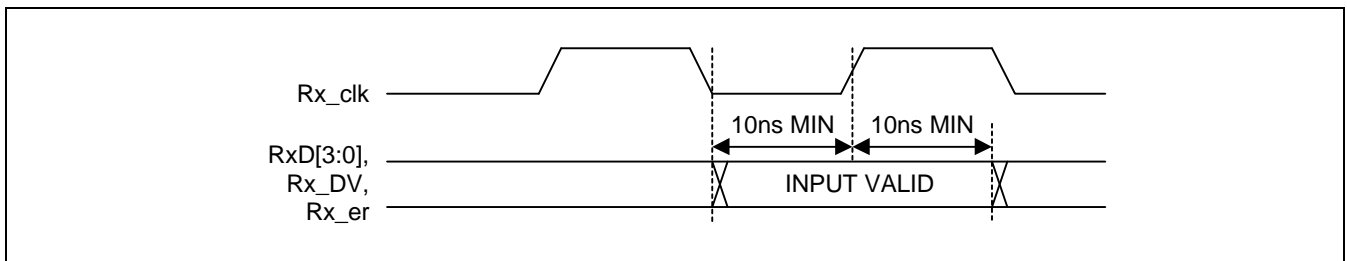

**Figure 7-26. Receive Signal Timing Relationship at MII**

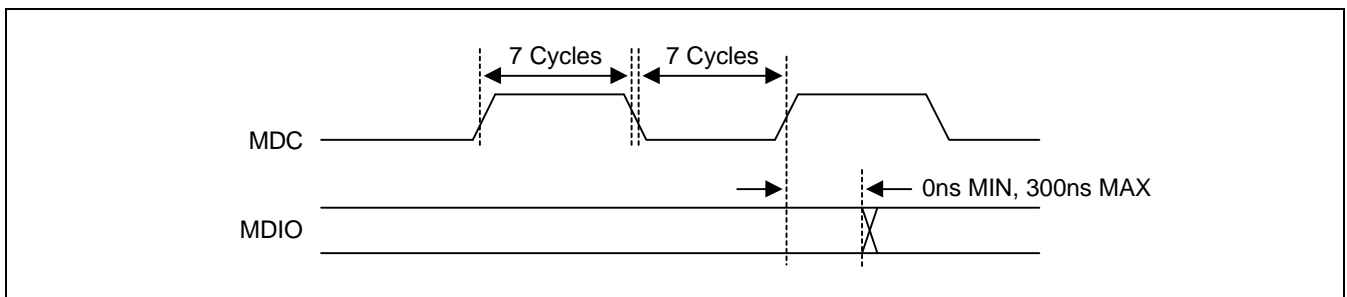

**Figure 7-27. MDIO Sourced by PHY**

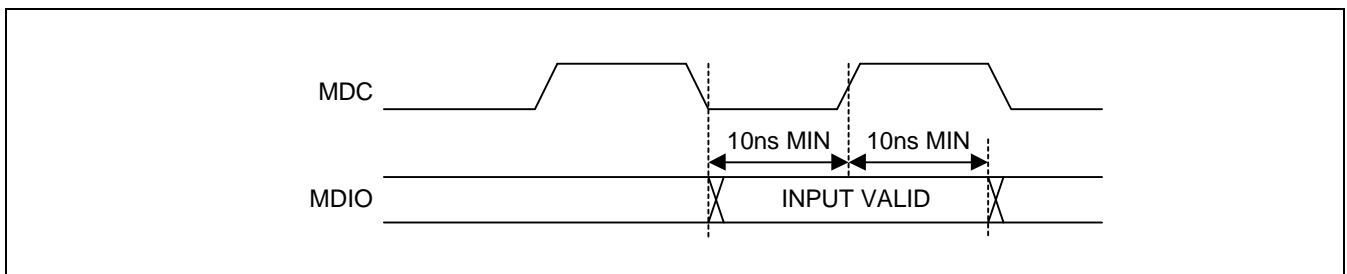

**Figure 7-28. MDIO Sourced by STA**

MAC CONTROLLER 7-WIRE INTERFACE TIMING

Table 7-46. 7-Wire Interface Receive Timing

Symbol	Condition	Min	Typ	Max	Unit
Ts_crs	CRS low to high setup time	0.92			ns
Th_crs	CRS low to high hold time	0.38			ns
Ts_dv	RX_DV set-up time	0.9			ns
Th_dv	RX_DV hold time	0.4			ns
Ts_d	RxD set-up time	0.79			ns
Th_d	RxD hold time	0.51			ns
Ts_er	Rx_er set-up time	0.9			ns
Th_er	Rx_er hold time	0.4			ns
Tcyc	Rx_clk clock period		100		ns

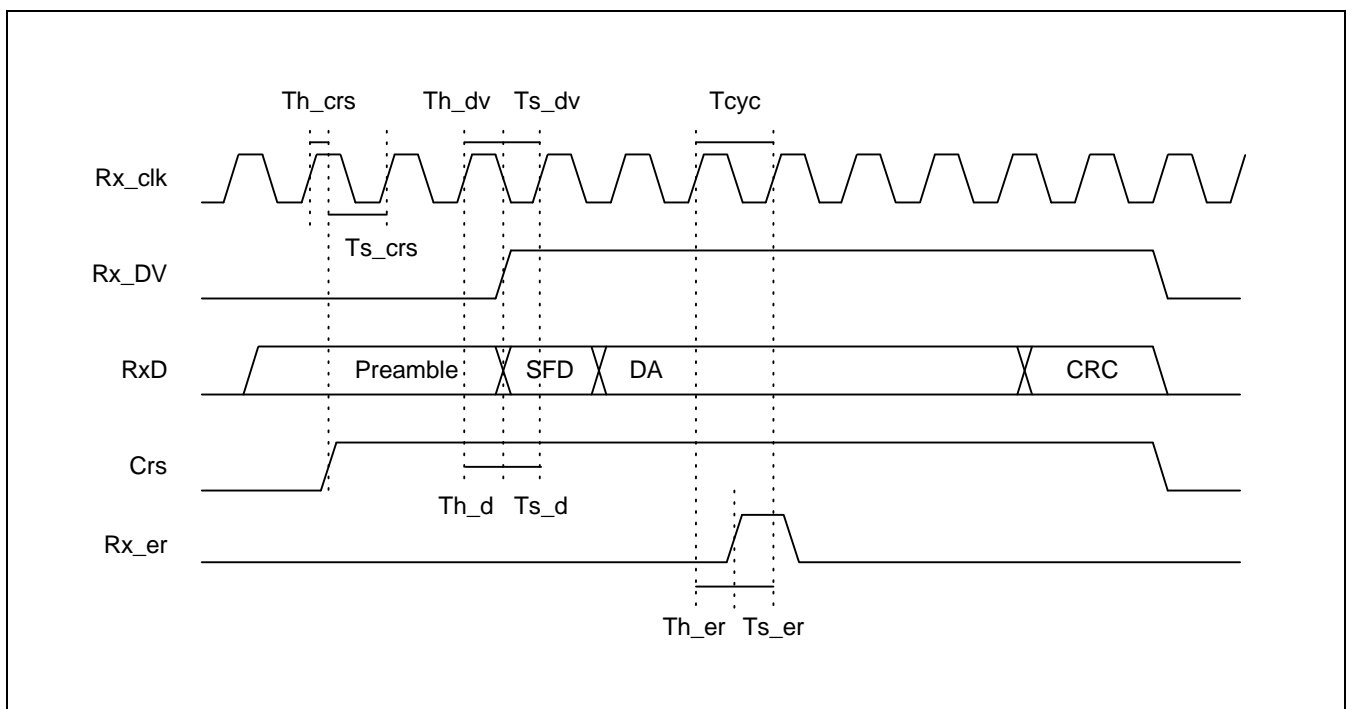

Figure 7-28. Rx Timing in 7 Wire Interface

Table 7-47. 7-Wire Interface Transmit Timing

Symbol	Condition	Min	Typ	Max	Unit
Ts_en	Tx_en set-up time	0.8			ns
Th_en	Tx_en hold time	0.71			ns
Ts_crs	CRS set-up time	0.72			ns
Th_crs	CRS hold time	0.75			ns
Ts_d	TxD set-up time	1.2			ns </td
Th_d	TxD hold time	0.5			ns
Ts_col	COL set-up time	0.82			ns
Th_col	COL hold time	0.79			ns
Tcol	COL minimum active time	200			ns

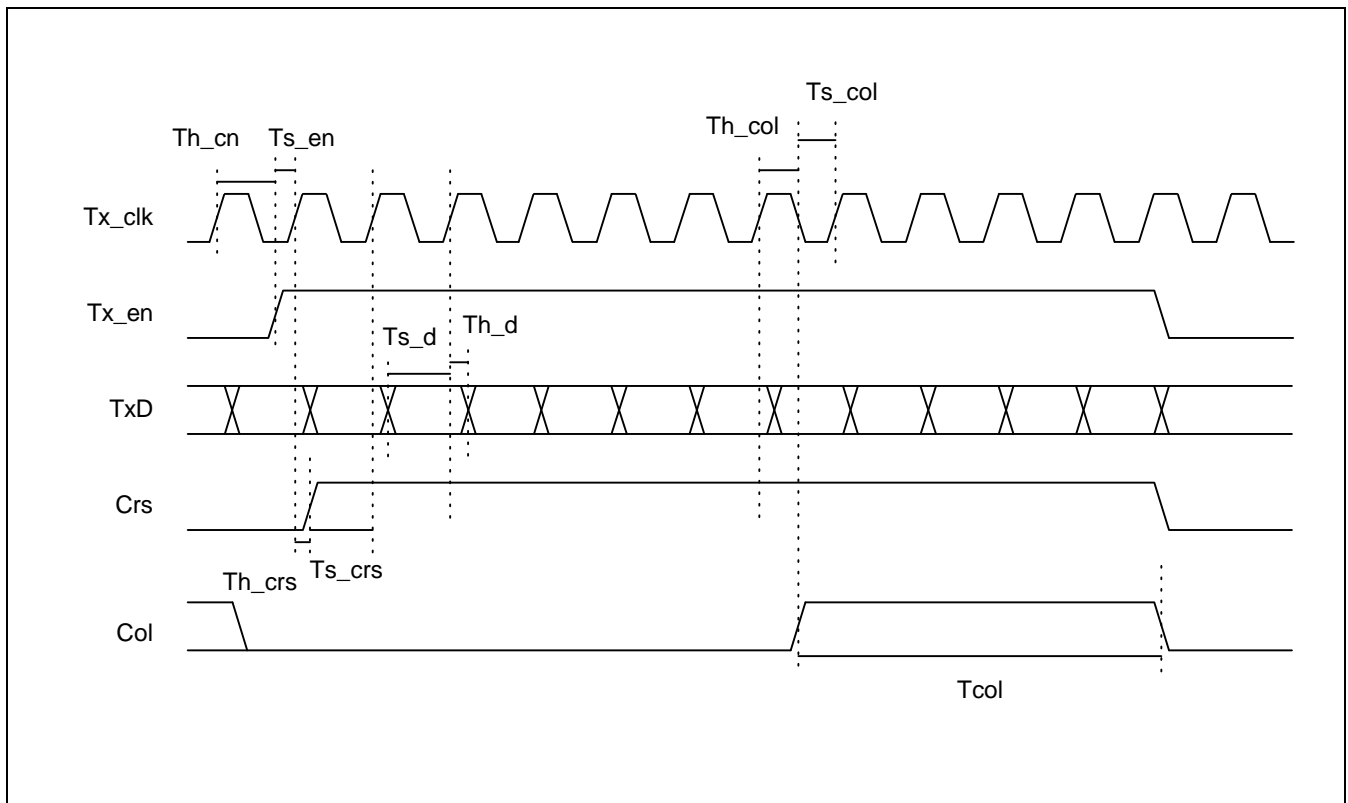

Figure 7-29. Tx Timing in 7 Wire Interface

# 8

## HDLC CONTROLLERS

### OVERVIEW

The S3C45310B has two high-level data link controllers (HDLCs) to support two-channel serial communications.

The HDLC module supports a CPU/data link interface that conforms to the synchronous data link control (SDLC) and high-level data link control (HDLC) standards. In addition, the following function blocks are integrated into the HDLC module:

- Two-channel DMA engine for Tx/Rx
- Support buffer descriptors per frame
- Digital phase-locked loop (DPLL) block
- Baud rate generator (BRG)

## FEATURES

Important features of the S3C4510B HDLC block are as follows:

- Protocol features:
  - Flag detection and synchronization
  - Zero insertion and deletion
  - Idle detection and transmission
  - FCS encoding and detection (16-bit)
  - Abort detection and transmission
- Four address station registers and one mask register for address search mode
- Selectable CRC/No-CRC mode
- Automatic CRC generator preset
- Digital PLL block for clock recovery
- Baud rate generator
- NRZ/NRZI/FM/Manchester data formats for Tx/Rx
- Loop-back and auto-echo mode
- Tx and Rx clock inversion
- Tx and Rx FIFOs with 8-word (8 x 32-bit) depth
- Selectable 1-word or 4-word data transfer mode for Tx/Rx
- Data alignment logic
- Endian translation
- Programmable interrupts
- Modem interface
- Hardware flow control
- Buffer descriptor for Tx / Rx
- Two-channel DMA Controller
  - Two channels for HTxFIFO and HRXFIFO
  - Single or 4-word (4 x 32-bit) burst transfer mode
  - Maximum frame size allows for up to 64K bytes
- Up to 10 Mbps full-duplex operation using an external/internal clock
- HDLC frame length based on octets



### FUNCTION DESCRIPTIONS

Figure 8-1 shows the HDLC module's function blocks. These function blocks are described in detail in the following sections.

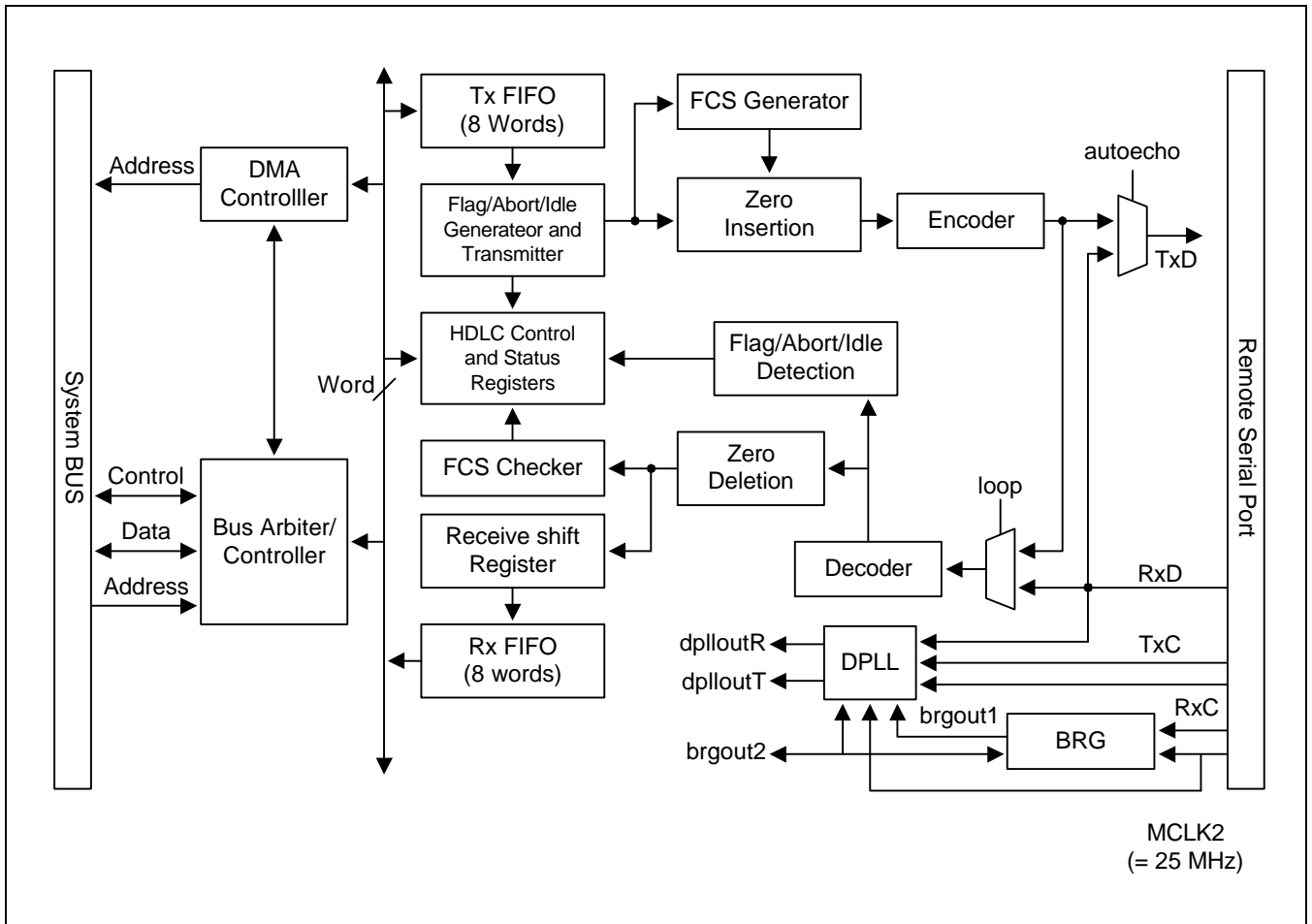

Figure 8-1. HDLC Module Block Diagram

## HDLC FRAME FORMAT

The HDLC transmits and receives data (address, control, information and CRC field) in a standard format called a frame. All frames start with an opening flag (beginning of flag, BOF, 7EH) and end with a closing flag (end of flag, EOF, 7EH). Between the opening and the closing flags, a frame contains an address (A) field, a control (C) field, an information (I) field (optional), and a frame check sequence (FCS) field (see Table 8-1).

**Table 8-1. HDLC Data Frame Format**

Opening Flag	Address Field	Control Field	Information Field	Frame Check Sequence Field	Closing Flag
01111110	8 bits per byte	8 bits per byte	8 bits per byte; variable length	16 bits	01111110

**NOTE:** The address field can be extended up to four bytes using a optional software control setting.

### Flag (F)

A flag is a unique binary pattern (01111110) that is used to delimit HDLC frames. This pattern is generated internally by the transmitter. An opening flag starts a frame and a closing flag ends the frame. Opening flags and closing flags are automatically appended to frames.

A single flag pattern can optionally serve as both the closing flag of one frame and the opening flag of the next one. This feature is controlled by the double-flag (FF), single-flag (F), or frame separator selection bit (the TxSDFL bit in the HCON register).

### Order of Bit Transmission

Address field, control field, and information field bytes are transferred between the CPU and the HDLC module in parallel over the data bus. These bytes are transmitted and received LSB first. The 16-bit frame check sequence (FCS) field is, however, transmitted and received MSB first.

**Address (A) Field**

The eight bits that follow the opening flag are called address (A) field. The address field are expendable. To extend this address byte, simply user-defined address write to the station address register. To check address byte against the incoming data, have to be used the MASK register. If match occurred, the frame's data including address and CRC(16-bit) into the HRXFIFO and then moved to system memory. If it is not matched, simply discarded. S3C4510B allows up to 32-bits address. For instance, SDLC and LAPB use an 8-bit address. LAPD further divides its 16-bit address into different fields to specify various access points one piece of equipment. Some HDLC-type protocol allows for extended addressing beyond 16-bit.

**Control (C) Field**

The eight bits that follow the address field are called the control (link control, C) field. The S3C4510B HDLC module treats the control field in the same way as the information field. That is, it passes the eight bits to the CPU or memory during reception. The CPU is responsible for how the control field is handled and what happens to it.

**Information (I) Field**

The information (I) field follows the control (C) field and precedes the frame check sequence (FCS) field. The information field contains the data to be transferred. Not every frame, however, must actually contain information data. The word length of the I-field is eight bits in the S3C4510B HDLC module. And its total length can be extended by 8 bits until terminated by the FCS field and the closing flag.

**Frame Check Sequence (FCS) Field**

The 16 bits that precede the closing flag comprise the frame check sequence (FCS) field. The FCS field contains the cyclic redundancy check character, CRCC. The polynomial  $x^{16} + x^{12} + x^5 + 1$  is used both for the transmitter and the receiver. Both the transmitter and the receiver polynomial registers are all initialized to 1 prior to calculating of the FCS. The transmitter calculates the frame check sequence of all address bits, control bits, and information fields. It then transmits the complement of the resulting remainder as the FCS value.

The receiver performs a similar calculation for all address, control, and information bits, as well as for all the FCS fields received. It then compares the result to F0B8H. When a match occurs, the frame valid (RxFV) status bit is set to '1'. When the result does not match, the receiver sets the CRC error bit (RxCRC) to '1'. The transmitter and the receiver automatically perform these FCS generation, transmission and checking functions. The S3C4510B HDLC module also supports NO CRC operation mode. In NO CRC mode, transmitter does not append FCS to the end of data and the receiver also does not check FCS. In this mode, the data preceding the closing flag is transferred to the HRXFIFO. In CRC mode, the FCS field is transferred to the HRXFIFO.

## PROTOCOL FEATURES

### INVALID FRAME

A valid frame must have at least the A, C, and FCS fields between its opening and closing flags. Even if no-CRC mode is set, the frame size should not be less than 32 bits. There are three invalid frame conditions:

- Short frame: a frame that contains less than 25 bits between flags. Short frames are ignored.
- Invalid frame: a frame with 25 bits or more, having a CRC compare error or non-byte-aligned. Invalid frames are transferred to the HRXFIFO, then the invalid frame error flag (RxCRC, RxNO in the status register) is set to indicate that an invalid frame has been received.
- Aborted frame: a frame aborted by the reception of an abort sequence is handled as an invalid frame.

### ZERO INSERTION AND ZERO DELETION

The zero insertion and zero deletion feature, which allows the content of a frame to be transparent, is handled automatically by the HDLC module. While the transmitter inserts a binary '0' following any sequence of five 1s within a frame, the receiver deletes a binary '0' that follows a sequence of five 1s within a frame.

### ABORT

The function of early termination of a data link is called an abort. The transmitter aborts a frame by sending at least eight consecutive 1s immediately after the abort transmitter control bit (TxABT in HCON) is set to '1'. (Setting this control bit automatically clears the HTxFIFO.)

The abort sequence can be extended up to (at least) 16 consecutive 1s by setting the abort extend control bit (TxABTEXT in HCON) to '1'. This feature is useful for forcing the mark idle state. The receiver interprets the reception of seven or more consecutive 1s as an abort.

The receiver responds to the abort received as follows:

- An abort in an 'out of frame' condition: an abort has no meaning during the idle or the time fill.
- An abort 'in frame' after less than 25 bits are received after an opening flag: under this condition, no field of the aborted frame is transferred to the HRXFIFO. The HDLC module clears the aborted frame data in the receiver and flag synchronization. The aborted reception is indicated in the status register.
- An abort 'in frame' after 25 bits or more are received after an opening flag: in this condition, some fields of the aborted frame may be transferred to the HRXFIFO. The abort status is set in the status register and the data of the aborted frame in the HRXFIFO is cleared. Flag synchronization is also cleared and the DMA operation for receiving is aborted too.

### IDLE AND TIME FILL

When the transmitter is not transmitting a frame, it is in an idle state. The transmitter signals that it has entered an idle state in one of the following two ways: 1) by transmitting a continuous series of flag patterns (time fill), or 2) by transmitting a stream of consecutive 1s (mark idle). The flags and mark idle are not transferred to the HRXFIFO.

The flag or mark idle selection bit (TxFLAG in HCON) controls this function: when TxFLAG is '0', mark idle is selected; when TxFLAGIDLE is '1', the time fill method is selected.

**FIFO STRUCTURE**

In both transmit and receive directions, 32-byte (8 word) deep FIFOs are provided for the intermediate storage of data between the serial interface and the CPU Interface.

**TWO-CHANNEL DMA ENGINE**

The HDLC module has a two-channel DMA engine for Tx/Rx FIFOs. The DMA Tx channel programming and the RX channel programming are described in the transmitter and receiver operation sections, respectively.

**BAUD RATE GENERATOR**

The HDLC module contains a programmable baud rate generator(BRG). The BRG register contains a 16-bit time constant register, a 12-bit down counter for time constant value, two control bit to divide 16, and another two control bits to divide 16 or 32.

A clock diagram of the BRG is shown in Figure 8-2.

At a start-up, the flip-flop on the output is set in a High state, the value in the time constant register is loaded into the counter, and the counter starts counting down. The output of the baud rate generator may toggle upon reaching zero, the value in the time constant register is loaded into the counter, and the process is repeated. The time constant may be changed any time, but the new value does not take effect until the next load of the counter.

The output of the baud rate generator may be used as either the transmit clock, the receive clock, or both. It can also drive the digital phase-locked loop. If the receive or transmit clock is not programmed to come from the TXC pin, the output of the baud rate generator may be echoed out via the TXC pin.

The following formula relates the time constant to the baud rate where MCLK2 or RXC is the baud rate generator input frequency in Hz. BRG generates 2 output signals, BRGOUT1, BRGOUT2, for transmit/receive clocks and the DPLL input clock.

$$BRGOUT1 = (MCLK2 \text{ or } RXC) / (CNT0 + 1) / (16^{CNT1})$$

$$BRGOUT2 = BRGOUT1 / (1 \text{ or } 16 \text{ or } 32 \text{ according to } CNT2 \text{ value of the HBRGTC})$$

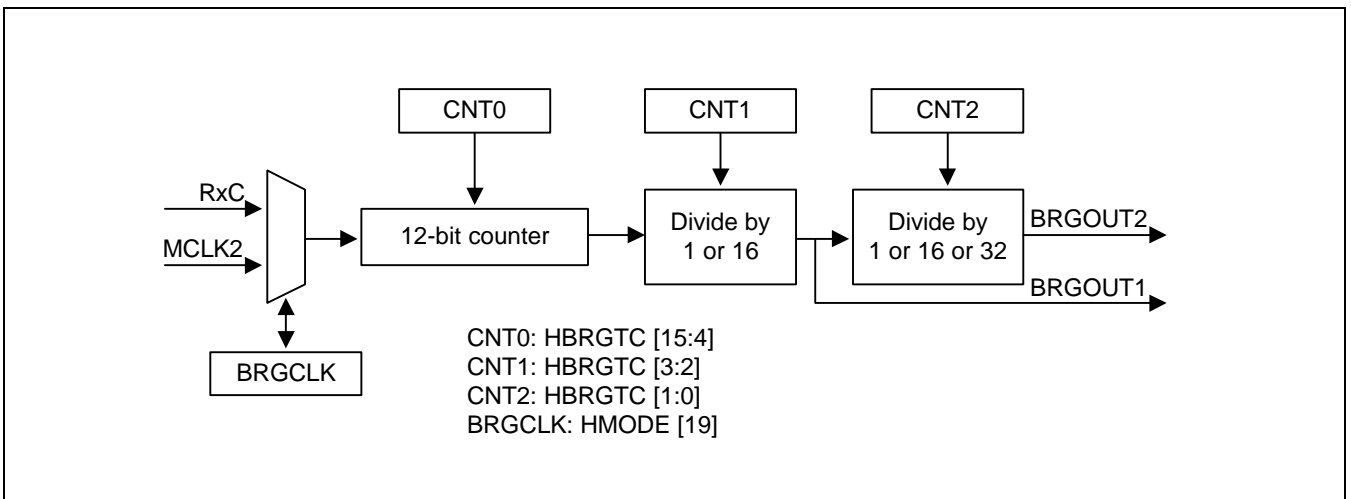

**Figure 8-2. Baud Rate Generator Block Diagram**

The example in the following Table assumes a 25 MHz clock from MCLK2, a 24.576 MHz clock from RxC, showing a time constant for a number of commonly used baud rates.

**Table 8-2. Baud Rate Example of HDLC**

Baud Rate (BRGOUT2)	MCLK = 25 MHz					RxC = 24.576 MHz				
	CNT0	CNT1	CNT2	Freq.	Dev.(%)	CNT0	CNT1	CNT2	Freq.	Dev.(%)
1200	1301	0	1	1200.1	0.0	1279	0	1	1200.0	0.0
2400	650	0	1	2400.2	0.0	639	0	1	2400.0	0.0
4800	324	0	1	4807.7	0.2	319	0	1	4800.0	0.0
9600	162	0	1	9585.9	- 0.1	159	0	1	9600.0	0.0
19200	80	0	1	19290.1	0.5	79	0	1	19200.0	0.0
38400	40	0	1	38109.8	- 0.8	39	0	1	38400.0	0.0
57600	26	0	1	57870.4	0.5	26	0	1	56888.9	-1.2
115200	13	0	1	111607.1	- 3.1	12	0	1	118153.8	2.6

**DIGITAL PHASE-LOCKED LOOP (DPLL)**

The HDLC module contains a digital phase-locked loop (DPLL) function to recover clock information from a data stream with NRZI or FM encoding. The DPLL is driven by a clock that is normally 32 (NRZI) or 16 (FM) times the data rate. The DPLL uses this clock, along with the data stream, to construct the clock.

This clock may then be used as the receive clock, the transmit clock, or both.

Figure 8-3 shows a block diagram of the digital phase-locked loop. It consists of a 5-bit counter, an edge detector and a pair of output decoders.

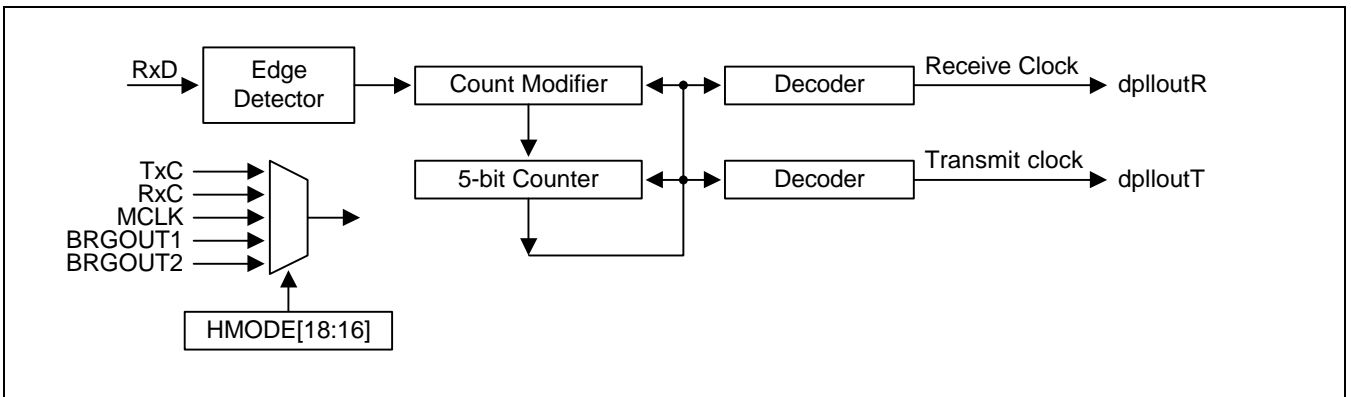

Figure 8-3. DPLL Block Diagram

**CLOCK USAGE METHOD**

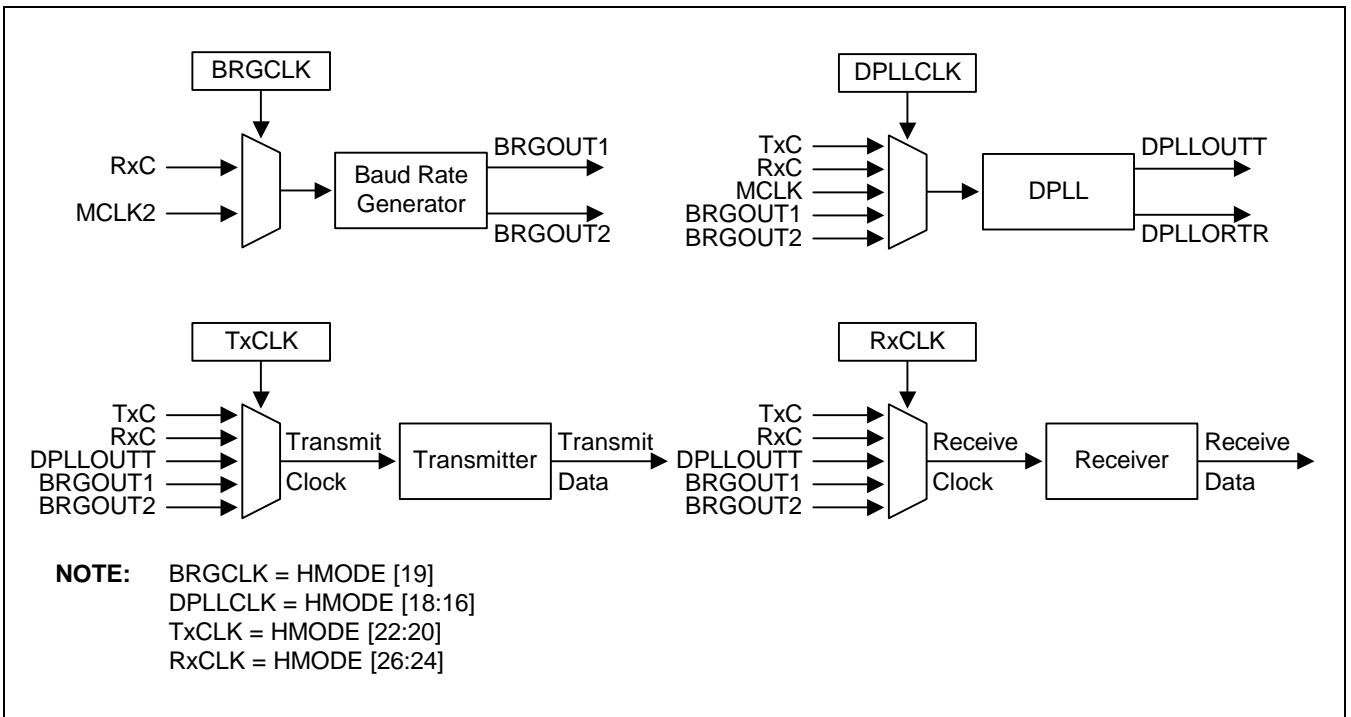

Figure 8-4. Clock Usage Method Diagram

In the NRZ/NRZI mode, the DPLL source clock must be 32 times the data rates. In this mode, the transmit and receive clock outputs of the DPLL are identical, and the clocks are phased so that the receiver samples the data in the middle of the bit cell.

The DPLL counts the 32x clock using an internal 5-bit counter. As the 32x clock is counted, the DPLL searches the incoming data stream for edges (either positive or negative transition). The output of DPLL is High while the DPLL is waiting for an edge in the incoming data stream. When it detects a transition, the DPLL starts the clock recovery operation.

The first sampling edge of the DPLL occurs at the counter value of 16 after the first edge is detected in the incoming data stream. The second sampling edge occurs following the next 16. When the transition of incoming data occurs at a count value other than 16, the DPLL adjusts its clock outputs during the next 0 to 31 counting cycle by extending or shortening its count by one, which effectively moves the edge of the clock sampling the receive data closer to the center of the bit cell.

The adding or subtracting of a count of 1 will produce a phase jitter of 5.63 degrees on the output. Because the DPLL uses both edges of the incoming signal for its clock source comparison, the mark-space ratio (50%) of the incoming signal must not deviate more than 1.5% of its baud rate if proper locking is to occur.

In the FM mode, the DPLL clock must be 16 times the data rate. The 5-bit counter in the DPLL counts from 0 to 31, so the DPLL makes two sampling clocks during the 0 to 31 counting cycle. The DPLL output is Low while the DPLL is waiting for an edge in the incoming data stream. The first edge the DPLL detects is assumed to be a valid clock edge. From this point, the DPLL begins to generate output clocks.

In this mode, the transmit clock output of the DPLL lags the receive clock outputs by 90 degrees to make the transmit and receive bit cell boundaries the same, because the receiver must sample the FM data at a one-quarter and three-quarters bit time.

You can program the 32X clock for the DPLL to originate from one of the RxC input pins, from the TxC pin, or from the baud rate generator output. You can also program the DPLL output to be "echoed out" of the HDLC module over the TXC pin (if the TXC pin is not being used as an input).

During idle time, you can set the TxPRMB in HCON to send the special pattern required for a remote DPLL to lock the phase. In this case, the content of the HPRMB register is sent repeatedly. The length of preamble is determined by TxPL bit in HMODE[10:8].

It is noticed that the frequency of the receive clock (RxC) should be slower than half of the internal system clock i.e., MCLK/2. Otherwise, the data transfer from receive FIFO to memory could be lost.



## HDLC OPERATIONAL DESCRIPTION

The following sections describe the operation of the HDLC module.

### HDLC INITIALIZATION

A power-on or reset operation initializes the HDLC module and forces it into the reset state. After a reset, the CPU must write a minimum set of registers, as well as any options set, based on the features and operating modes required.

First, the configuration of the serial port and the clock mode must be defined. These settings include the following:

- Data format select
- BRG clock select
- DPLL clock select
- Transmit clock select
- Receive clock select
- BRG/DPLL enable to use internal clock

You must also set the clock for various components before each component is enabled. Additional registers may also have to be programmed, depending on the features you select. All settings for the HDLC mode register, HMODE, and the HDLC control register, HCON, must be programmed before the HDLC is enabled.

To enable the HDLC module, you must write a '1' to the receiver enable bit and/or the transmitter enable bit. During normal operation, you can disable the receiver or the transmitter by writing a '0' to the RxEN or TxEN bit, respectively. You can disable the receiver and HRXFIFO or the transmitter and HTxFIFO by writing a '1' to the RxRS or TxRS bit, respectively.

**HDLC DATA ENCODING/DECODING**

Data encoding is utilized to allow the transmission of clock and data information over the same medium. This saves the need to transmit clocks and data over a separate medium as would normally be required for synchronous data. The HDLC provides four different data encoding methods, selected by bits in HCON1[18:16]. An example of these four encoding methods is shown in figure 8-5.

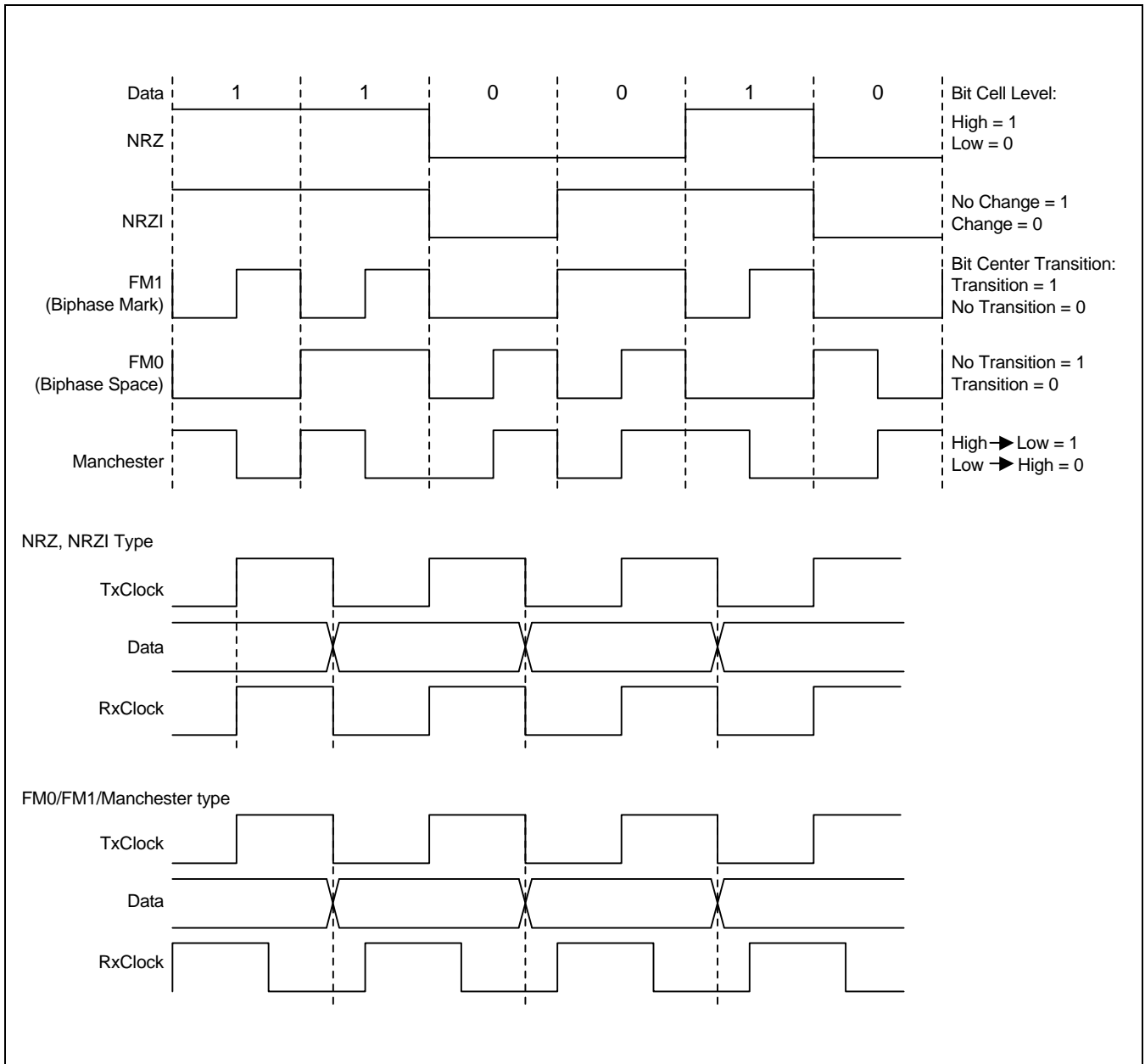

**Figure 8-5. Data Encoding Methods and Timing Diagrams**

**HDLC DATA SETUP AND HOLD TIMING WITH CLOCK**

You can see the timing of TxD and RxD in terms of TxC and RxC HDLC clock in Figure 8-6.

**Table 8-3. HMODEA and HMODEB Register**

Symbol	Condition	Min	Typ	Max	Unit
Ttxdf	TxD falling edge delay time	9.82		10.66	ns
Trxdf	TxD falling edge delay time	1.0			ns

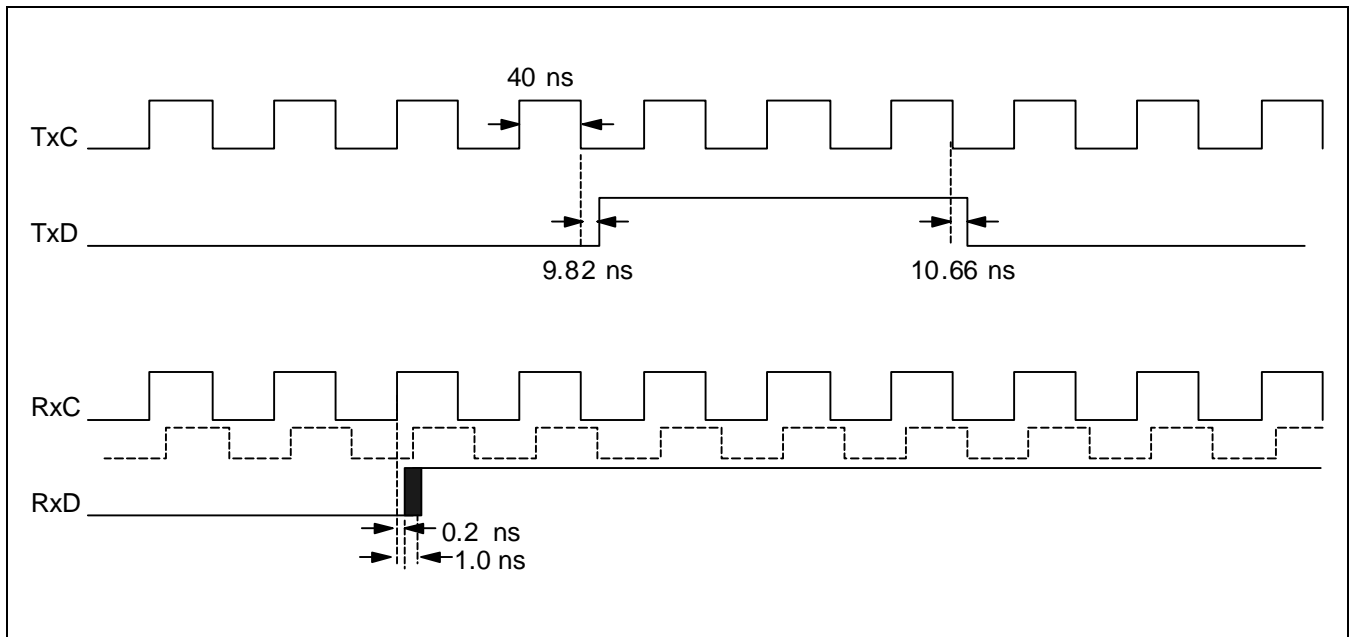

**Figure 8-6. Data Encoding Methods and Timing Diagrams**

Tx data will be sent with delayed 9.82 nsec to 10.66 nsec from the falling edge of Tx Clock. In case of RxD, the black period should not be changed. That is, the RxD should be stable from 0.2nsec to 1.0nsec after RxC rising edge. (It does not allow data transition during this period) The RxC will be Rx(receiver) clock through Rx clock selection part with some delay. And this RxC delay is larger then RxD delay. In Figure 8-6, the dotted-clock is real internal Rx clock used by the receiver. Therefore, there should not be transit in Rx data to avoid setup or hold violation.

## HDLC TRANSMITTER OPERATION

The HTxFIFO register cannot be pre-loaded when the transmitter is disabled. After the HDLC Tx is enabled, the flag or mark idle control bit (TxFLAG in HCON) is used to select either the mark idle state (inactive idle) or the flag 'time fill' (active idle) state. This active or inactive idle state will continue until data is loaded into the HTxFIFO.

The content of the HPRMB register can be sent out by setting the TxPRMB in HCON for the remote DPLL before the data is loaded into the HTxFIFO. The length of preamble to be transmitted is determined by TxPL bits in HMODE.

The availability of data in the HTxFIFO is indicated by the HTxFIFO available bit (TxFA in HSTAT) under the control of the 4-word transfer mode bit (Tx4WD in HCON).

When you select 1-word transfer mode (not 4-word select mode), one word can be loaded into the HTxFIFO (assuming the TxFA bit is set to '1'). When you select 4-word transfer mode, four successive words can be transferred to the FIFO if the TxFA bit is set to '1'.

The nCTS (clear-to-send) input, nRTS (request-to-send), and nDCD (data-carrier-detect) are provided for a modem or other hardware peripheral interface.

In auto enable mode, nDCD becomes the receiver enable. However, the receiver enable bit must be set before the nDCD pin is used in this manner.

The TxFC status bit(in HSTAT) can cause an interrupt to be generated upon frame completion (This bit is set when there is no data in HTxFIFO and when the closing flag or an abort is transmitted).

### Transmitter Interrupt Mode

The first byte of a frame (the address field) should be written into the Tx FIFO at the 'frame continue' address. Then, the transmission of the frame data starts automatically. The bytes of the frame continue to be written into the Tx FIFO as long as data is written to the 'frame continue' address. The HDLC logic keeps track of the field sequence within the frame.

The frame is terminated when the last frame data is written to the Tx FIFO's 'frame terminate' address. The FCS field is automatically appended by hardware, along with a closing flag. Data for a new frame can be loaded into the Tx FIFO immediately after the previous frame data, if TxFA is '1'. The closing flag can serve as the opening flag of the next frame or separate opening and closing flags can be transmitted. If a new frame is not ready to be transmitted, a flag time fill or mark idle pattern is transmitted automatically.

If the Tx FIFO becomes empty at any time during the frame transmission, an underrun occurs and the transmitter automatically terminates the frame by transmitting an abort. The underrun state is indicated when the transmitter underrun status bit (TxU) is '1'.

Whenever you set the transmission abort control bit (TxABT in HCON), the transmitter immediately aborts the frame (transmits at least eight consecutive 1s), clearing the Tx FIFO. If the transmission abort extension control bit (TxABTEXT) is set at the time, an idle pattern (at least 16 consecutive 1s) is transmitted. An abort or idle in an out- of-frame condition can be useful to gain 8 or 16 bits of delay time between read and write operations.

### Transmitter DMA Mode

To use DMA operation without CPU intervention, you have to make Tx buffer descriptor chain in advance. And set the DMA Tx buffer descriptor pointer (DMATxPTR) register to the address of the first buffer descriptor of the chain, and then DMA Tx channel should be enabled.

When Tx underrun or CTS lost condition occurs during DMA operation, DMA Tx enable bit(HCON[6]) is cleared and DMA Tx operation is stopped. This situation is reported to system with DTxABT bit set (HSTAT[22]).

In case of Tx underrun, abort signal sent and then idle pattern is sent if TxEN bit is set. In case of CTS lost, TxD output goes high state as long as CTS remains high level.

## HDLC RECEIVER OPERATION

The HDLC receiver is provided with data and a pre-synchronized clock by means of the RxD and the internal DPLL clock, the TxC pin, or the RxC pin. The data is a continuous stream of binary bits. One of the characteristics of this bit stream is that a maximum of five consecutive 1s can occur unless an abort, flag, or idle condition occurs. The receiver continuously searches (bit-by-bit) for flags and aborts.

When a flag is detected, the receiver synchronizes the frame to the flag timing. If a series of flags is received, the receiver re-synchronizes the frame to each successive flag.

If the frame is terminated because of a short frame condition (frame data is less than 32 bits after an opening flag), the frame is simply ignored. Noise on the data input line (RxD) during time fill can cause this kind of invalid frame.

The received data which is clocked by the external TxC or RxC, or by an internal DPLL or BRG source enters a 56-bit or 32-bit shift register before it is transferred into the HRXFIFO. Synchronization is established when a flag is detected in the first eight locations of the shift register. When synchronization has been achieved, data is clocked through to the last byte location of the shift register where it is transferred into the HRXFIFO.

In 1-word transfer mode, when the HRXFIFO available bit (RxFA) is '1', data is available at least in one-word. In 4-word transfer mode, the RxFA is '1' when data is available in the last four FIFO register locations (registers 4, 5, 6, and 7). The nDCD input is provided for a modem or other hardware interface. If AutoEN bit in HCON[28] is set to '1', the receiver operation is dependent on the nDCD input level.

Otherwise, receiver operation is free of the nDCD input level.

### Receiver Interrupt Mode

Whenever data is available in the HRXFIFO, an interrupt is generated by RxFA (if the interrupt is enabled). The CPU reads the HDLC status register either in response to the interrupt request or in turn during a polling sequence.

When the received data available bit(RxFA) is '1', the CPU can read the data from the HRXFIFO. If the CPU reads normal data or address data from the HRXFIFO, the RxFA bit is automatically cleared.

In CRC mode, the 16 bits preceding the closing flag are regarded as the FCS and checked by hardware, and they are transferred to the HRXFIFO. Also, in no CRC mode, without the hardware checking, all data bits preceding the closing flag are transferred to the HRXFIFO. When the closing flag is sent to the receiver, the frame is terminated. Whatever data is present in the most significant byte of the receiver, the shift register is right justified and transferred to the HRXFIFO. The frame boundary pointer, which is explained in the HRXFIFO register section, is set simultaneously in the HRXFIFO. When the last byte of the frame appears at the 1-word or 4-word boundary location of the HRXFIFO, depending on the settings of the Rx4WD control bit, the frame boundary pointer sets the frame valid status bit (if the frame is completed with no error) or the RxCRCE status bit(if the frame was completed, but with a CRC error).

If the frame reception is completed, an RxCRCE interrupt (for a frame error) or an RxFV interrupt (for normal state) is generated. At this point, the CPU can read the Rx remaining bytes (RxRB) status bits to know how many bytes of this frame still remain in the HRXFIFO.

When you set the frame discontinue control bit (the incoming frame discard control bit) to '1', the receiver discards the current frame data without dropping the flag synchronization. You can use this feature to ignore a frame with a non-matched address.

**Receiver DMA Mode**

To use DMA operation without CPU intervention, you have to make Rx buffer descriptor chain in advance. And set the DMA Rx buffer descriptor pointer (DMARxPTR) register to the address of the first buffer descriptor of the chain, and then DMA Rx channel should be enabled.

**HARDWARE FLOW CONTROL**

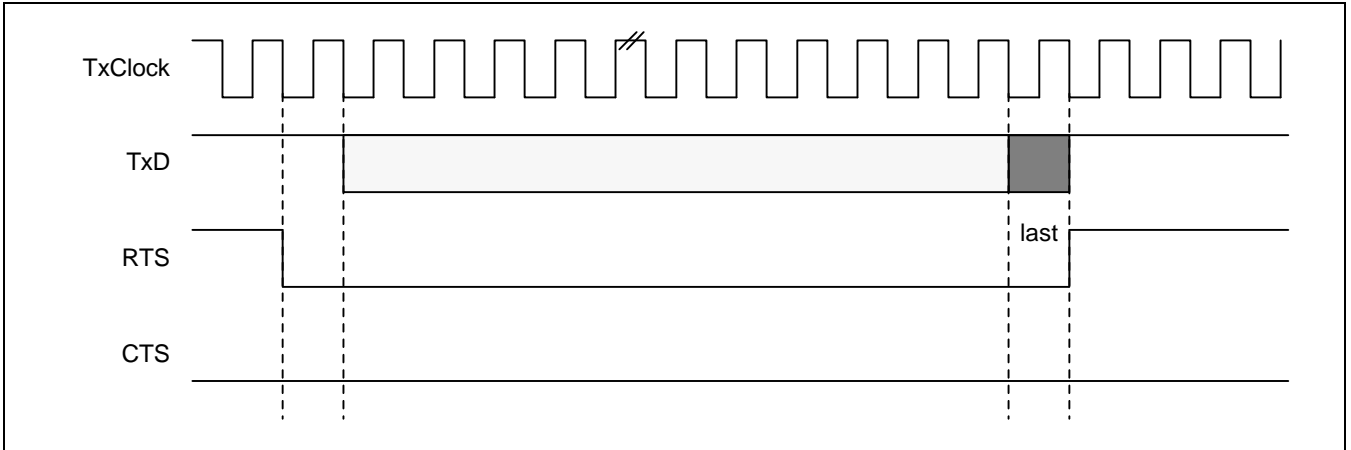

**Figure 8-7. nCTS Already Asserted**

When nCTS is active and there exists data to be transmitted in Tx FIFO, nRTS enters Low, allowing data transmission. At the beginning of the data is an open flag while at the end a closing flag. If the frame being transferred discontinues, nRTS goes back to the High after the data transmission is completed.

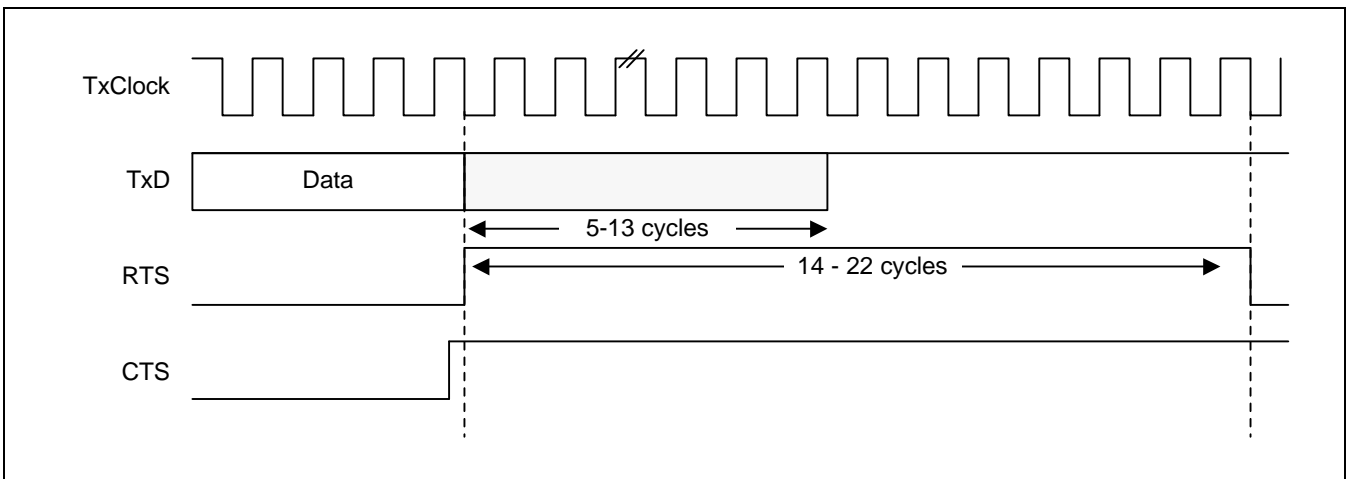

**Figure 8-8. CTS Lost during Transmission**

When the condition of nCTS is shifted from Low to High, it is detected at the falling edge of Tx clock, where nRTS also goes High. For about 5 to 13 cycles after nRTS enters High, the data transmission continues. nRTS remains High for a maximum of 22 cycles and goes back to the Low condition if there remains any data to be transmitted in HTxFIFO. If nCTS is still High even when nRTS went back to Low, not the data in HTxFIFO but a mark idle pattern is transmitted when AutoEn bit set to one.

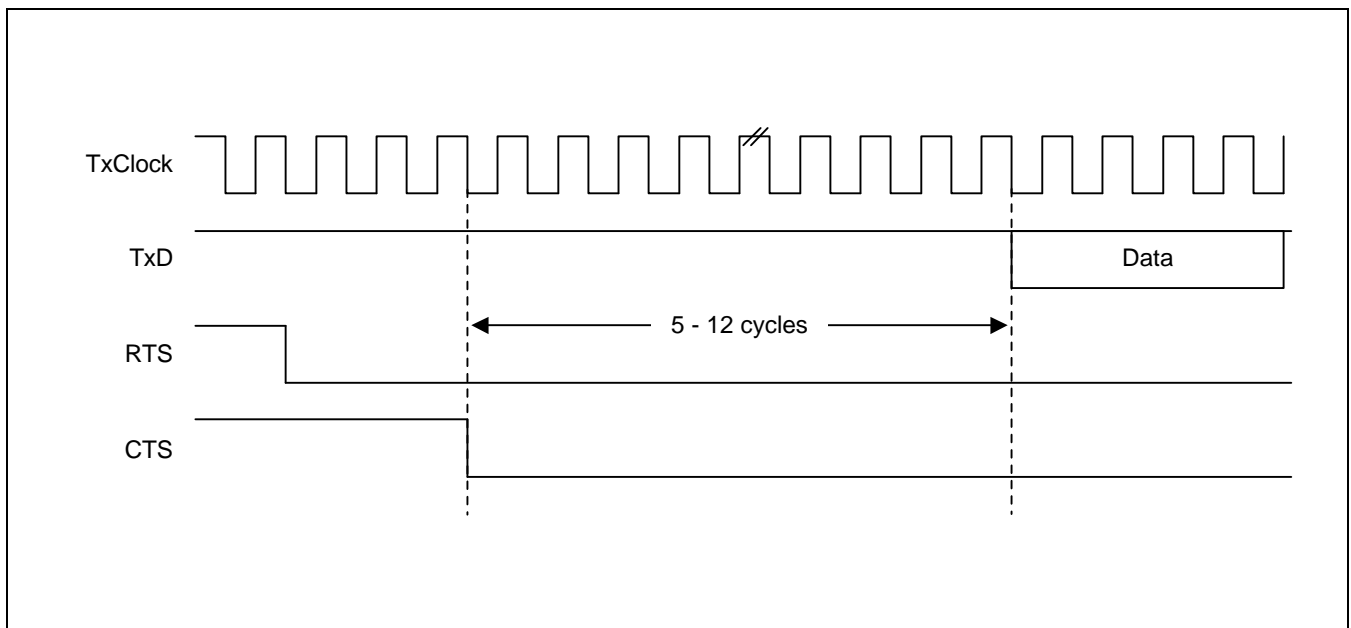

**Figure 8-9. CTS Delayed on**

If nCTS remains still High for a while after nRTS enters Low to allow data transmission from HTxFIFO, the data transmission starts 5-12 cycles after nCTS is shifted to Low



**MEMORY DATA STRUCTURE**

The flow control to the HDLC controller uses two data structures to exchange control information and data.

- Transmit buffer descriptor
- Receive buffer descriptor

Each Tx DMA buffer descriptor has the following elements.

- Buffer data pointer
- Ownership bit
- Control field for transmitter
- Status field for Tx
- Transmit buffer length
- Next buffer descriptor pointer

Each Rx DMA buffer descriptor has the following elements.

- Buffer data pointer
- Ownership bit
- Status field for Rx
- Accumulated received buffer length for a frame
- Next buffer descriptor pointer

## DATA BUFFER DESCRIPTOR

The ownership bit in the MSB of the buffer data pointer controls the ownership of the descriptor. When the ownership bit is '1', the DMA controller owns the descriptor. When this bit is '0', the CPU has the descriptor. The owner of the descriptor always owns the associated data frame. (The descriptor's buffer data pointer field always points to this buffer for about a frame.)

As it receives the data, the software sets the maximum frame length register. If the received data is longer than the value of the maximum frame length register, this frame is ignored and the FLV bit is set. The software also sets the DMA Rx buffer descriptor pointer to point to a chain of buffer descriptors, all of which have their ownership bit.

The DMA controller can be started to set the DMA Rx enable bit in the control register. When a frame is received, it is moved into memory at the address specified by the DMA Rx data buffer pointer. If a frame is longer than the value of the RxBuf Size register, then the next buffer descriptors are fetched to receive the frame.

That is, to handle a frame, one or more buffer descriptors could be used. Please note that no configurable offset or page boundary calculation is required. The received frame is moved to the buffer memory whose address is pointed to by the buffer data pointer until the end of frame, or until the length exceeds the maximum frame length configured. If the length exceeds the maximum frame length configured, the frame length violated bit is set.

If the entire frame is received successfully, the status bits in the receive buffer descriptor are set to indicate the received frame status. The ownership bit in the buffer descriptor pointer is cleared by the CPU which has the ownership and an interrupt may now be generated. The DMA controller copies the next buffer descriptor pointer into the DMA Rx buffer descriptor pointer register.

If the next buffer descriptor pointer is null(0), the DRxEN bit is cleared, and DMA Rx operation is stopped. Otherwise, the descriptor is read, and the DMA controller starts again with the next data, as described in the previous paragraph.

When the DMA reads a descriptor, if the ownership bit is not set, it has two options:

- Skip to the next buffer descriptor when DRxSTSK bit is '0'
- Generate an interrupt and halt the DMA operation when DRxSTSK bit is '1'

During transmission, the two-byte frame length at the Tx buffer descriptor is moved to the DMA internal Tx register. After transmission, the Tx status is saved in the Tx buffer descriptor. The DMA controller then updates the next buffer descriptor pointer for the linked list structure.

When the DMA Tx buffer descriptor register points to the first buffer descriptor, the transmitter starts transmitting the frame data from the buffer memory to Tx FIFO.





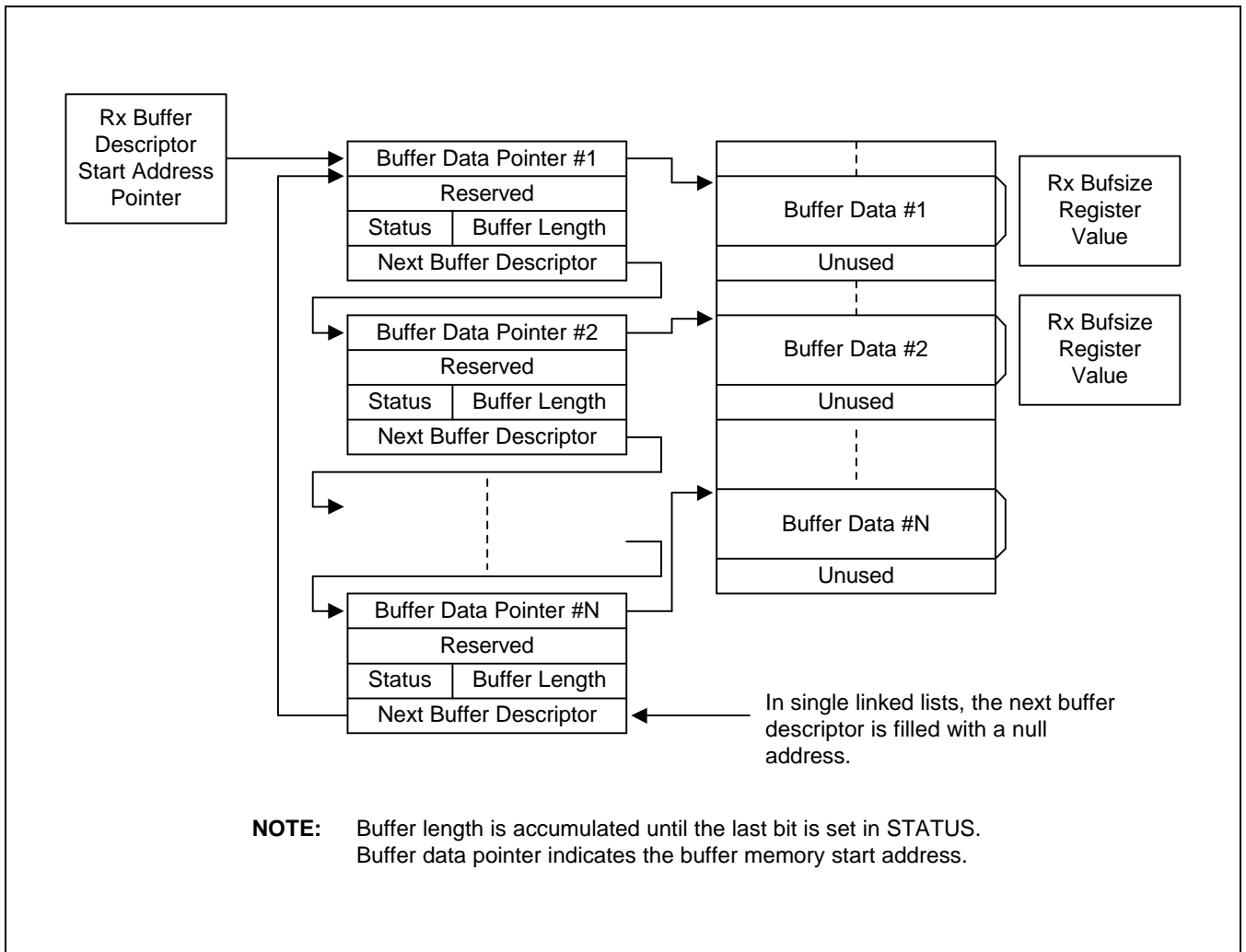

Figure 8-12. Data Structure of the Receive Data Buffer

## HDLC SPECIAL REGISTERS

The HDLC special registers are defined as read-only or write-only registers according to the direction of information flow. The addresses of these registers are shown in Table 8-4 and 8-5.

The transmitter FIFO register can be accessed using two different addresses, the frame terminate address and the frame continue address. The functions of these addresses are discussed in detail in the FIFO section below.

**Table 8-4. HDLC Channel A Special Registers**

Registers	Offset	R/W	Description	Reset Value
HMODE	0x7000	R/W	HDLC mode register	0x00000000
HCON	0x7004	R/W	HDLC control register	0x00000000
HSTAT	0x7008	R/W	HDLC status register	0x00000000
HINTEN	0x700c	R/W	HDLC interrupt enable register	0x00000000
HTxFIFOC (Frame Continue)	0x7010	W	HTxFIFO frame continue register	–
HTxFIFOT (Frame Terminate)	0x7014	W	HTxFIFO frame terminate register	–
HRxFIFO	0x7018	R	HRxFIFO entry register	0x00000000
HBRGTC	0x701c	R/W	HDLC BRG time constant register	0x00000000
HPRMB	0x7020	R/W	HDLC preamble register	0x00000000
HSAR0	0x7024	R/W	HDLC station address 0	0x00000000
HSAR1	0x7028	R/W	HDLC station address 1	0x00000000
HSAR2	0x702c	R/W	HDLC station address 2	0x00000000
HSAR3	0x7030	R/W	HDLC station address 3	0x00000000
HMASK	0x7034	R/W	HDLC mask register	0x00000000
HDMATxPTR	0x7038	R/W	DMA Tx buffer descriptor pointer	0xFFFFFFFF
HDMARxPTR	0x703c	R/W	DMA Rx buffer descriptor pointer	0xFFFFFFFF
HMFLR	0x7040	R/W	Maximum frame length register	0xFFFF0000
HRBSR	0x7044	R/W	Receive buffer size register	0xFFFF0000

Table 8-5. HDLC Channel B Special Registers

Registers	Offset	R/W	Description	Reset Value
HMODE	0x8000	R/W	HDLC mode register	0x00000000
HCON	0x8004	R/W	HDLC control register	0x00000000
HSTAT	0x8008	R/W	HDLC status register	0x00000000
HINTEN	0x800c	R/W	HDLC interrupt enable register	0x00000000
HTxFIFOC (Frame Continue)	0x8010	W	HTxFIFO frame continue register	–
HTxFIFOT (Frame Terminate)	0x8014	W	HTxFIFO frame terminate register	–
HRxFIFO	0x8018	R	HRxFIFO entry register	0x00000000
HBRGTC	0x801c	R/W	HDLC BRG time constant register	0x00000000
HPRMB	0x8020	R/W	HDLC preamble register	0x00000000
HSAR0	0x8024	R/W	HDLC station address 0	0x00000000
HSAR1	0x8028	R/W	HDLC station address 1	0x00000000
HSAR2	0x802c	R/W	HDLC station address 2	0x00000000
HSAR3	0x8030	R/W	HDLC station address 3	0x00000000
HMASK	0x8034	R/W	HDLC mask register	0x00000000
HDMATxPTR	0x8038	R/W	DMA Tx buffer descriptor pointer	0xFFFFFFFF
HDMARxPTR	0x803c	R/W	DMA Rx buffer descriptor pointer	0xFFFFFFFF
HMFLR	0x8040	R/W	Maximum frame length register	0xFFFF0000
HRBSR	0x8044	R/W	Receive buffer size register	0xFFFF0000

HDLC GLOBAL MODE REGISTER

Table 8-6. HMODEA and HMODEB Register

Registers	Offset	R/W	Description	Reset Value
HMODEA	0x7000	R/W	HDLC Mode register	0x00000000
HMODEB	0x8000	R/W	HDLC Mode register	0x00000000

Table 8-7. HMODE Register Description

Bit Number	Bit Name	Description
[0]	Multi-Frame in HTxFIFO in DMA operation (MFF)	If this bit is set, more than one frame can be loaded into HTxFIFO. In this case, the frame size may be less than the FIFO size.
[1]	Reserved	Not applicable.
[2]	Rx clock inversion(RXCINV)	If this bit set to '0', the receive clock samples the data at the rising edge. If this bit set to '1', the receive clock samples the data at the falling edge.
[3]	Tx clock inversion(TXCINV)	If this bit set to '0', the transmit clock shifts the data at the falling edge. If this bit set to '1', the transmit clock shifts the data at the rising edge.
[4]	Rx Little-Endian mode (RxLittle)	This bit determines whether the data is in Little- or Big-endian format. HRXFIFO is in Little-endian. If this bit is set to '0', then the data on the system bus should be in Big-endian. Therefore the bytes will be swapped in Big- endian.
[5]	Tx Little-Endian mode (TxLittle)	This bit determines whether Tx data is in Little or Big endian (TxLittle) format. HTxFIFO is in Little-endian. If this bit is set to '1', the data on the system bus is Little endian. If this bit is set to '0', the data on the system bus is in Big-endian. (that is, the data bytes are swapped to be Little endian format.)
[7:6]	Reserved	Not applicable
[10:8]	Tx preamble length(TxPL)	These bits determine the length of preamble to be sent before the opening flag when the TxPRMB bit is set in the control register. 000 1byte, 001 2bytes,and 111 8bytes will be sent.
[11]	Reserved	Not applicable
[14:12]	Data formats (DF)	When the DF bits are '000', data is transmitted and received in the NRZ data format. When DF is '001', the NRZI (zero complement) data format is selected. DF = '010' selects the FM0 data format, DF = '011' the FM1 data format, and DF = '100' the Manchester data format.
[15]	Reserved	Not applicable
[18:16]	DPLL clock select (DPLLCLK)	Using this setting, you can configure the clock source for DPLL to one of the following pins: TxC, RxC, MCLK, BRGOUT1, or BRGOUT2. To select one of these pins, set the DPLLCLK bits to '000', '001', '010', '011', or '100', respectively.



Table 8-7. HMODE Register Description (Continued)

Bit Number	Bit Name	Description
[19]	BRG clock select (BRGCLK)	If this bit is '1', MCLK2 is selected as the source clock for the baud rate generator (BRG). If this bit is '0', the external clock at the RXC pin is selected as the BRG source clock.
[22:20]	Tx clock select (TxCLK)	Using this setting, you can configure the transmit clock source to one of the following pins: TxC, RxC, DPLLOUTT, BRGOUT1, or BRGOUT2. To select one of these pins, set the TxCLK bits to '000', '001', '010', '011', or '100', respectively.
[26:24]	Rx clock select (RxCLK)	Using this setting, you can configure the receive clock source to one of the following pins: TxC, RxC, DPLLOUTR, BRGOUT1, or BRGOUT2. To select one of these pins, set the RxCLK bits to '000', '001', '010', '011', or '100', respectively.
[30:28]	TxC output pin select (TxCOPS)	If you do not use the clock at the TxC pin as the input clock, you can use the TxC pin to monitor TxCLK, RxCLK, BRGOUT1, BRGOUT2, DPLLOUTT, and DPLLOUTR. To select the clock you want to monitor, set the TxCOPS to '000', '001', '010', '011', or '100', respectively.
[31]	Reserved	Not applicable.



## HDLC CONTROL REGISTER

Table 8-8. HCONA and HCONB Register

Registers	Offset	R/W	Description	Reset Value
HCONA	0x7004	R/W	HDLC channel A control register	0x00000000
HCONB	0x8004	R/W	HDLC channel B control register	0x00000000

Table 8-9. HCON Register Description

Bit Number	Bit Name	Description
[0]	Tx reset (TxRS)	Set this bit to '1' to reset the Tx block. Tx block comprises HTxFIFO and a transmitter block.
[1]	Rx reset (RxRS)	Set this bit to '1' to reset the Rx block. Rx block comprises HRXFIFO and a receiver block.
[2]	DMA Tx reset (DTxRS)	Set this bit to '1' to reset the DMA Tx block.
[3]	DMA Rx reset (DRxRS)	Set this bit to '1' to reset the DMA Rx block.
[4]	Tx enable (TxEN)	When the TxEN bit is '0', the transmitter enters a disabled state and the line becomes high state. In this case, the transmitter block is cleared except for the HTxFIFO and the status bits associated with transmit operation are cleared. Data cannot be loaded into the HTxFIFO. If this bit is set to '1', the idle pattern is sent continuously. In this case, the data can be loaded into HTxFIFO, and then sent.
[5]	Rx enable (RxEN)	When the RxEN bit is '0', the receiver enters a disabled state and can not detect the flag pattern, if any. In this case, receiver block is cleared except for the HRXFIFO and the status bits associated with receiver operation are cleared. Data cannot be received. If this bit is set to '1', the flag pattern is detected. In this case, the data received can be loaded into the HRXFIFO, and moved to system memory.
[6]	DMA Tx enable (DTxEN)	The DTxEN bit lets the HDLC Tx operate on a bus system in DMA mode. When DMA Tx is enabled, an interrupt request caused by TxFA status is inhibited and the HDLC does not use the interrupt request to request a data transfer. DMA Tx monitors the HTxFIFO and fills the HTxFIFO. This bit is auto disabled when Tx underrun occurs, or CTS lost, or next buffer descriptor pointer reach null, or the owner bit is not DMA mode when DTxSTSK bit is set. If Tx underrun occurs, DTxABT(in HSTAT) bit set, and abort signal sended. If CTS lost occurs, DTxABT bit set and TxD output goes high state as long as CTS remains high level.

**Table 8-9. HCON Register Description (Continued)**

Bit Number	Bit Name	Description
[7]	DMA Rx enable (DRxEN)	<p>The DRxEN bit lets the HDLC Rx operate on a bus system in DMA mode. When DMA Rx is enabled, an interrupt request caused by the RxFA status is inhibited, and the HDLC does not use the interrupt request to request a data transfer. DMA Rx monitors the HRXFIFO and moves the data from the HRXFIFO to memory. This bit is automatically disabled when the next buffer descriptor pointer becomes null, or the owner bit is not in DMA mode when the DTxSTSK bit is set.</p>
[8]	DPLL enable (DPLLEN)	<p>Setting this bit enables the DPLL, causing the DPLL to enter search mode. In Search mode, the DPLL searches for a locking edge in the incoming data stream.</p> <p>After DPLL is enabled (in NRZI mode for example), the DPLL starts sampling immediately after the first edge is detected. (In FM mode, the DPLL examines the clock edge of every other bit to decide what correction must be made to remain in sync.) If the DPLL does not detect an edge during the expected window, it sets the one clock missing bit.</p> <p>If the DPLL does not detect an edge after two successive attempts, it sets the two clock missing bit and the DPLL automatically enters the Search mode. To reset both clocks missing latches, you can disable and re-enable the DPLL using the reset Rx status.</p>
[9]	BRG enable (BRGEN)	<p>This bit controls the operation of the baud rate generator (BRG). To enable the BRG counter, set the BRGEN bit to '1'. To inhibit counting, clear the bit to '0'.</p>
[10]	Tx 4 word mode (Tx4WD)	<p>When this bit is '0', and TxFA bit in status register is '1', it is indicated that Tx FIFO is empty for 1 word. It means that 1-word data can be loaded to Tx FIFO.</p> <p>Similarly, when this bit is '1', the same status register bit indicate that 4 words of data can be loaded to Tx FIFO without reading the status bit for a second time.</p> <p>Specifically, the status register bit affected by the 1-word or 4-word transfer setting are the transmit data available (TxFA) bit.</p>
[11]	Rx 4 word mode (Rx4WD)	<p>When this bit is '0', and the RxFA bit in the status register is '1', it is indicated that Rx FIFO has 1-word data. It means that 1 word data can be moved to memory.</p> <p>Similarly, when this bit is '1', the same status register bit indicates that 4 words of data can be moved in the memory without reading the status bit for a second time.</p> <p>Specifically, the status register bit affected by the 1-word or 4-word transfer setting are the receive data available (RxFA) bit, and the residue bytes status bits, RxRB[3:0].</p>

Table 8-9. HCON Register Description (Continued)

Bit Number	Bit Name	Description
[13:12]	Rx widget alignment (RxWA)	These bits determine how many bytes are invalid in the first memory word of the frame to be received. The invalid bytes are inserted when the word is assembled in the HRXFIFO. '00' =No Invalid bytes; '01' = 1 invalid byte, '10' = 2 invalid bytes, '11' = 3 invalid bytes.
[14]	DMA Tx stop or skip (DTxSTSK)	This bit determines a DMA Tx stop or skip when DMA has not the ownership associated with the Tx buffer descriptor. DMA Tx is disabled in this condition when this bit is set.
[15]	DMA Rx stop or skip (DRxSTSK)	This bit determines a DMA Rx stop or skip when DMA has not the ownership associated with the Rx buffer descriptor. If this bit is set, DMA Rx is disabled.
[16]	DMA Rx memory address decrement (DRxMADEC)	This bit determines whether the address is incremented or decremented. If this bit is set to '1', then the address will be decremented.
[17]	Tx flag idle (TxFLAG)	This bit selects the flag 'time fill' mode (active idle) or the mark idle mode (inactive idle) for the transmitter. The selected active or inactive idle state continues until data is sent (after nRESET has return to High level). The flag idle pattern is 7EH; the mark idle pattern is FFH.
[18]	Tx single flag (TxSFLAG)	This bit controls whether separate closing and opening flags are transmitted in succession to delimit frames. When this bit is '0', independent opening and closing flags are transmitted in order to separate frame.  When this bit is set to '1', the closing flag of the current frame serves as the opening flag of the next frame.
[19]	Tx loop-back mode (TxLOOP)	This bit is used for self-testing. If this bit is set to '1', the transmit data output (TxD) is internally connected to the receiver data input (RxD). In Loop-back mode, nCTS and nDCD inputs are ignored. For normal operation, this bit should always be '0'.
[20]	Rx echo mode (RxECHO)	Setting this bit to '1' selects the auto-echo mode of operation. In this mode, the TxD pin is connected to RxD as in local loop-back mode, but the receiver still monitors the RxD input.
[21]	Tx abort extension (TxABTEXT)	When this bit is set to '1', the abort pattern that is initiated when TxABT = '1' is extended to at least 16 bits of 1s in succession, and the mark idle state is entered.
[22]	Tx abort (TxABT)	When this bit is set to '1', an abort sequence of at least eight bits of 1s is transmitted. The abort is initiated and the HTxFIFO is cleared. TxABT is then cleared automatically by hardware.

**Table 8-9. HCON Register Description (Continued)**

Bit Number	Bit Name	Description
[23]	Tx preamble (TxPRMB)	When this bit is set to '1', the content of the HPRMB register is transmitted as many TxPL bit values in interrupt mode instead of mark idle or time fill mode. This is useful for sending the data needed by the DPLL to lock the phase. In DMA mode, this bit is meaningless.
[24]	Tx data terminal ready (TxDTR)	The TxDTR bit directly controls the nDTR output state. Setting this bit forces the nDTR pin to Low level. When you clear the TxDTR bit, nDTR goes High.
[25]	Rx frame discontinue (RxDISCON)	When this bit is set, the frame currently received is ignored and the data in this frame is discarded. Only the last frame received is affected. There is no effect on subsequent frames, even if the next frame enters the receiver when the discontinue bit is set. This bit is automatically cleared after a cycle.
[26]	Tx no CRC (TxNOCRC)	When this bit is set to '1', the CRC is not appended to the end of a frame by hardware.
[27]	Rx no CRC (RxNOCRC)	When this bit is set to '1', the receiver does not check for CRC by hardware. (CRC data is always moved to the HRxFIFO.)
[28]	Auto enable (AutoEN)	<p>This bit programs the function of both nDCD and nCTS. However, TxEN and RxEN must be set before the nCTS and nDCD pins can be used.</p> <p>When this bit is '0', if the nCTS becomes high, the transmitter sends mark idle pattern. However, though the nDCD becomes high, the receiver can receive the data.</p> <p>When this bit is '1', if the nCTS becomes high, the transmitter send mark idle but clears the HTxFIFO and the Tx block. If nDCD becomes high, the receiver can't operate, and the HRxFIFO and Rx blocks are cleared.</p>
[31:29]	Reserved	Not applicable.







**HDLC STATUS REGISTER (HSTAT)****NOTE**

Reading the HDLC status register is a non-destructive process. The method used to clear a High-level status condition depends on the bit's function and operation mode (DMA or interrupt). For details, please see the description of each status register.

**Table 8-10. HSTATA and HSTATB Register**

<b>Registers</b>	<b>Offset</b>	<b>R/W</b>	<b>Description</b>	<b>Reset Value</b>
HSTATA	0x7008	R/W	HDLC Channel A Status Register	0X00000000
HSTATB	0x8008	R/W	HDLC Channel B Status Register	0X00000000

**SUMMARY**

There are two kinds of bits in a status register.

1. TxFA, TxCTS, RxFA, RxDCD, RxFV, RxCRCE, RxNO, RxIERR, and RxOV bits are show each bit's status. These bits are set or cleared automatically according to the each bit status.
2. All other bits are cleared by the CPU writing '1' to each bit.

**Table 8-11. HSTAT Register Description**

Bit Number	Bit Name	Description
[3:0]	Rx remaining bytes (RxRB)	(RxRB + 1) indicates how many data bytes are valid in a 1-word or 4-word boundary when the receiver has received a complete frame. In 1-word transfer mode, the RxRB value is either 0, 1, 2, or 3. In 4-word mode, it is 0, 1, ..., 14, or 15.
[4]	Tx frame complete (TxFC)	This status bit is automatically set to '1' when the two conditions are met: 1) there is no data in the Tx FIFO, and 2) either an abort or a closing flag is transmitted. You can clear this bit by writing '1' to this bit.
[5]	Tx FIFO available (TxFA)	If this bit is '1', the data to be sent can be loaded into the HTxFIFO register. In 1-word transfer mode, the TxFA status bit is set to '1' when the first register of the HTxFIFO is empty.  In 4-word transfer mode, TxFA = '1' when the first four 32-bit registers of the HTxFIFO are empty. The TxFA status condition is automatically cleared when HTxFIFO is no longer available. During DMA Tx operation, this bit is always '0', so not generating interrupt.
[6]	Tx clear-to-send (TxCTS)	The nCTS input is projected to this status bit. If the level at the nCTS input pin is Low, this status bit is '1'. If nCTS input pin is High level, TxCTS is '0'. This bit does not generate an interrupt.
[7]	Tx stored clear-to-send (TxSCTS)	This bit is set to '1' each time a transition in nCTS input occurs. You can clear this bit by writing '1' to this bit.
[8]	Tx under-run (TxU)	When the transmitter runs out of data during a frame transmission, an underrun occurs and the frame is automatically terminated by transmitting an abort sequence. The underrun condition is indicated when TxU is '1'. You can clear this bit by writing a '1' to this bit.
[9]	Rx FIFO available (RxFA)	This status bit indicates when the data received can be read from the Rx FIFO. When RxFA is '1', it indicates that data (other than an address or a final data word) is available in the HRXFIFO. In 1-word transfer mode, RxFA bit set to '1' when received data is available in the last FIFO register. In 4-word transfer mode, it is set to '1' when the data received is available in the last four 32-bit FIFO registers. Even if the data reside in FIFO for only two words, when the Last bit is set, Rx FIFO is regarded as valid. (The received data available condition is cleared automatically when the data received is no longer available.) During DMA Rx operation, this bit is always '0', so does not generate an interrupt.
[10]	Reserved	No applicable.

Table 8-11. HSTAT Register Description (Continued)

Bit Number	Bit Name	Description
[11]	Rx flag detected (RxFD)	This bit is set to '1' when the last bit of the flag sequence is received. This bit generates an interrupt if enabled. You can clear this bit by writing a '1' to this bit.
[12]	Rx data carrier detected (RxDCD)	The DCD status bit mirrors the state of the nDCD input pin. If nDCD input pin is low, this status bit is '1'. If nDCD input pin is High, it is '0'. This bit does not generate an interrupt.
[13]	Rx stored data carrier detected (RxSDCD)	This bit is set to '1' when a transition in nDCD input occurs, and can generate interrupt, if enabled. You can clear this bit by writing a '1' to this bit.
[14]	Rx frame valid (RxFV)	This bit signals frame's ending boundary to the CPU and also indicates that no frame error occurred. It is set when the last data byte of a frame is transferred into the last location of the Rx FIFO and is available to be read.
[15]	Rx idle (RxIDLE)	The RxIDLE status bit indicates that a minimum of 15 consecutive 1s have been received. The event is stored in the status register and can be used to trigger a receiver interrupt. The RxIDLE bit continues to reflect the inactive idle condition until a '0' is received. You can clear this bit by writing a '1' to this bit.
[16]	Rx abort (RxABT)	The RxABT status bit is set to '1' when seven or more consecutive 1s (abort sequence) have been received. When an abort is received in an 'in-frame' condition, the event is stored in the status register triggering an interrupt request. You can clear this bit by writing a '1' to this bit.
[17]	Rx CRC error (RxCRCE)	The RxCRCE status bit is set a frame is completed with a CRC error.
[18]	Rx non-octet align (RxNO)	The RxNO bit is set to '1', if received data is non-octet aligned frame.
[19]	Rx overrun (RxOV)	The RxOV status bit is set to '1', if the data received is transferred into the HRXFIFO when it is full, resulting in a loss of data. Continued overruns destroy data in the first FIFO register.
[20]	DMA Rx memory overflow (RxMOV)	This bit is set when there is no more buffer during receiving data. If this bit is set, DRxEN bit is cleared. You can clear this bit by writing '1' to this bit.
[21]	Reserved.	Not applicable.
[22]	DMA Tx abort (DTxABT)	This bit is set to '1' when abort signal is sent due to the Tx underrun or CTS lost occurred. If this bit is set, DTxEN(in HCON) bit cleared. You can clear this bit by writing '1' to this bit.

**Table 8-11. HSTAT Register Description (Continued)**

Bit Number	Bit Name	Description
[23]	Rx internal error (RxIERR)	This bit is set to '1' when received frame will be detected error possibility due to the receive clock is unstable.
[24]	DMA Rx frame done every received frame (DRxFD)	This bit is set when a DMA Rx operation has successfully operated a frame to memory from HRXFIFO, and when the last byte of a frame has been written to memory. This bit generate interrupt when set to '1' to know a frame is received. You can clear this bit by writing '1' to this bit.
[25]	DMA Rx null list (DRxNL)	If this bit is set, the DMA Rx buffer descriptor pointer has a null address. In this case, DMA Rx is disabled and the data transfer from the Rx FIFO to buffer memory is discontinued. So the HRXFIFO is cleared. You can clear this bit by writing '1' to this bit.
[26]	DMA Rx not owner (DRxNO)	This bit is set, when DMA is not owner of the current buffer descriptor, and DRxSTSK bit was set. In this case, DMA Rx is disabled and can generate interrupt, if enabled. If DRxSTSK bit is zero, this bit is always zero. You can clear this bit by writing '1' to this bit.
[27]	DMA Tx frame done (DTxFD)	In case of MFF bit is '0' (default), when DNA Tx operation has successfully transferred rest byte of frame from Tx FIFO to destination, this bit will be set to '1'. But if MFF is set to '1', transceiver will keep sending the data until there is no data transfer from memory to TxFIFO.
[28]	DMA Tx null list (DTxNL)	If this bit is set '1', the DMA Tx buffer descriptor pointer has a null address. In this case, DMA Tx is disabled and the data to be transferred discontinued from the buffer memory to Tx FIFO. You can clear this bit by writing '1' to this bit.
[29]	DMA Tx not owner (DTxNO)	This bit is set, when DMA is not owner of the current buffer descriptor, and DTxSTSK bit was set. In this case, DMA Tx disabled and can generate interrupt, if enabled. If DTxSTSK bit is zero, this bit is always zero. You can clear this bit by writing '1' to this bit.
[30]	DPLL one clock missing (DPLL0M)	When operating in FM/Manchester mode, the DPLL sets this bit to '1' if it does not detect an edge in its first attempt. You can clear this bit by writing a '1' to this bit.
[31]	DPLL two clock missing (DPLL2M)	When it is operating in the FM/Manchester mode, the DPLL sets this bit to '1' if it does not detect an edge in two successive attempts. At the same time the DPLL enters Search mode. In NRZ/NRZI mode, and while the DPLL is disabled, this bit is always '0'. You can clear this bit by writing a '1' to this bit.

31	30	29	28	27	26	25	24	23	22	21	20	19	18	17	16	15	14	13	12	11	10	9	8	7	6	5	4	3	2	1	0
D P L L T M	D P L L O M	D T x N O	D T x N L	D T x F D	D R x N O	D R x N L	D R x F D	R x I E R R	D T x A B T		R x M O V	R x O V	R x N O	R x C R C E	R x A B T	R x I D L E	R x F V	R x S D C D	R x D C D	R x F D		R x F A	T x U	T x S C T S	T x C T S	T x F A	T x F C			R x R B	

**[3:0] Rx remaining bytes (RxRB)**

At 1-word boundary:

0000 = Valid data byte is 1

0001 = Valid data byte is 2

0010 = Valid data byte is 3

0011 = Valid data byte is 4

At 4-word boundary:

0000 = Valid data byte is 1

.

.

1111 = Valid data byte is 16

**[4] Tx frame complete (TxFC)**

0 = Normal operation

1 = Automatically set; if two conditions are met:

- 1) Tx FIFO is empty.
- 2) An abort or a closing flag is transmitted.

**[5] Tx FIFO available (TxFA)**

0 = Tx FIFO is not available.

1 = Tx FIFO is available. (that is, the data to be transmitted can now be loaded into the Tx FIFO.)

**[6] Tx clear-to send (TxCTS)**

0 = Level at the nCTS input pin is High.

1 = Level at the nCTS input pin is Low.

**[7] Tx stored clear-to-send (TxSCTS)**

0 = Normal operation

1 = A transition occurred at the nCTS input. (This transition can be used to trigger an interrupt.)

**[8] Tx underrun (TxU)**

0 = Normal operation

1 = The transmitter ran out of data during transmission.

**[9] Rx FIFO available (RxFA)**

0 = Normal operation

1 = Data is available in the Rx FIFO.

**[10] Reserved****[11] Rx flag detected (RxFD)**

0 = Normal operation

1 = This bit is set, when the last bit of the flag sequence is received.

**[12] Rx data-carrier-detected (RxD CD)**

0 = nDCD input pin is High

1 = nDCD input pin is Low

**[13] Rx stored data-carrier-detected (RxSDCD)**

0 = Normal operation

1 = When a transition of the nDCD input occurs, this bit is set.

**[14] Rx frame valid (RxFV)**

0 = Normal operation

1 = The last data byte if a frame is transferred into the last location of Rx FIFO.

**[15] Rx idle (RxIDLE)**

0 = Normal operation

1 = A minimum 15 consecutive 1s have been received.

Figure 8-16. HDLC Status Register

31	30	29	28	27	26	25	24	23	22	21	20	19	18	17	16	15	14	13	12	11	10	9	8	7	6	5	4	3	2	1	0
D P L L T M	D P L L O M	D T x N O	D T x N L	D T x F D	D R x N O	D R x N L	D R x F D	R x I E R R	D T x A B T		R x M O V	R x O V	R x N O	R x C R C E	R x A B T	R x I D L E	R x F V	R x S D C D	R x D C D	R x F D		R x F A	T x U	T x S C T S	T x C T S	T x F A	T x F C			R x R B	

**[16] Rx abort (RxABT)**

0= Normal operation

1 = Seven or more consecutive 1s have been received, in-frame condition.

**[17] Rx CRC error (RxCRCE)**

0 = Normal operation

1 = A frame Rx operation is completed with a CRC error.

**[18] Rx non-octet align (RxNO)**

0 = Received frame is octet.

1 = Received frame is not octet.

**[19] Rx overrun (RxOV)**

0 = Normal operation

1 = Received data is transferred into the RxFIFO when it is full.

**[20] Rx memory overflow (RxMOV)**

0 = Normal operation

1 = Indicates memory overflow when Rx buffer descriptor next pointer has null address.

**[21] Reserved**

**[22] DMA Tx abort (DTxABT)**

0 = Normal operation

1 = Abort signal is sent and DMA Tx enable bit is cleared.

**[23] Rx internal error (RxIERR)**

0 = Normal operation

1 = Received frame is not stable due to receive clock is unstable.

**[24] DMA Rx frame done every received frame (DRxFD)**

0 = Normal operation

1 = DMA Rx operation has successfully transferred a frame from RxFIFO to buffer memory.

**[25] DMA Rx null list (DRxNL)**

0 = Normal operation

1 = DMA Rx buffer descriptor pointer has a null address.

**[26] DMA Rx not owner (DRxNO)**

0 = DMA has the ownership.

1 = CPU has the ownership.

**[27] DMA Tx frame done (DTxFD)**

0 = Normal operation

1 = DMA Tx operation has successfully transferred a frame from memory to TxFIFO.

**[28] DMA Tx null list (DTxNL)**

0 = Normal operation

1 = DMA Tx buffer descriptor pointer has a null address.

**[29] DMA Tx not owner (DTxNO)**

0 = DMA has the ownership.

1 = CPU has the ownership.

**[30] DPLL one clock missing (DPLL0M)**

0 = Normal operation

1 = Set in FM/Machester mode when DPLL does not detect an edge on the first entry.

**[31] DPLL two clock missing (DPLLTM)**

0 = Normal operation

1 = DPLL was not detected on two consecutive edges and search mode was entered.

Figure 8-17. HDLC Status Register (Continued)

## HDLC INTERRUPT ENABLE REGISTER (HINTEN)

Table 8-12. HINTENA and HINTENB Register

Registers	Offset	R/W	Description	Reset Value
HINTENA	0x700c	R/W	HDLC Interrupt Enable Register	0X00000000
HINTENB	0x800c	R/W	HDLC Interrupt Enable Register	0X00000000

Table 8-13. HINTEN Register Description

Bit Number	Bit Name	Description
[3:0]	Reserved	–
[4]	TxFCIE	Tx frame complete interrupt enable
[5]	TxFAIE	Tx FIFO available to write interrupt enable
[6]	Reserved	–
[7]	TxSCTSIE	CTS transition has occurred interrupt enable
[8]	TxUIE	Tx under-run has occurred interrupt enable
[9]	RxFAIE	Rx FIFO available to read interrupt enable
[10]	Reserved	–
[11]	RxFDIE	Rx flag detected interrupt enable
[12]	Reserved	–
[13]	RxSDCDIE	DCD transition interrupt enable
[14]	RxFVIE	Rx frame valid interrupt enable
[15]	RxIDLEIE	Idle detected interrupt enable
[16]	RxABTIE	Abort detected interrupt enable
[17]	RxCRCEIE	CRC error frame interrupt enable
[18]	RxNOIE	Non-octet aligned frame interrupt enable
[19]	RxOVIE	Rx overrun interrupt enable
[20]	RxMOVIE	Rx memory overflow interrupt enable
[21]	Reserved	–
[22]	DTxABTIE	DMA Tx abort interrupt enable
[23]	RxIERRIE	Rx internal error interrupt enable
[24]	DRxFDIE	DMA Rx frame done interrupt enable
[25]	DRxNLIE	DMA Rx null list interrupt enable
[26]	DRxNOIE	DMA Rx not owner interrupt enable
[27]	DTxFDIE	DMA Tx frame done every transmitted frame interrupt enable
[28]	DTxNLIE	DMA Tx null list interrupt enable
[29]	DTxNOIE	DMA Tx not owner interrupt enable
[30]	DPLL0MIE	DPLL one clock missing interrupt enable
[31]	DPLL2MIE	DPLL two clocks missing interrupt enable

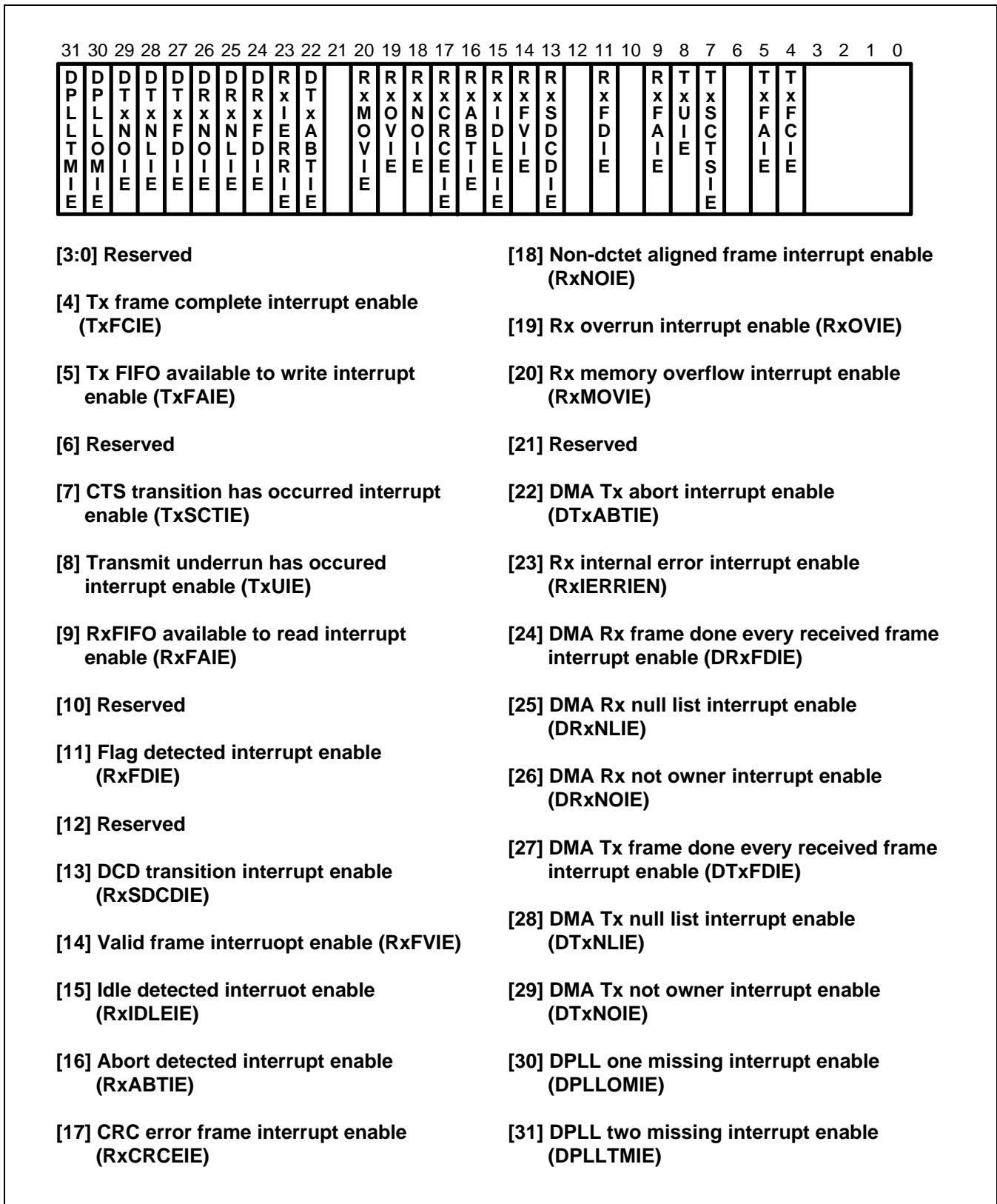

Figure 8-18. HDLC Interrupt Enable Register



**HDLC TX FIFO (HTXFIFO)**

The Tx FIFO consists of eight 32-bit registers that are used for buffer storage of data to be transmitted. Data is always transferred from a full register to an empty adjacent register. The Tx FIFO can be addressed at two different register addresses: the 'frame continue' address and the 'frame terminate' address.

Each register has four pointers, data valid pointer bit (4 bits), last pointer bit, NoCRC pointer bit, Preamble pointer bit. The data valid pointer bit indicates whether each byte is valid or not. The last byte pointer bit indicates whether the frame to be sent has the frame last byte or not. The NoCRC pointer bit determines whether the CRC data is to be appended or not by hardware.

When a valid data byte is written to the 'frame continue' address, the data valid pointer is set, but the last byte pointer is not set. When a valid data byte is written to the 'frame terminate' address, the data valid pointer and last byte pointer are set together. To reset these pointers, you write a '1' to either the TxABT bit or the TxRS bit in the HCON register.

In DMA mode, when the DMA controller writes data to the HTxFIFO, Tx buffer descriptor Buffer Length field value must be pre-set. However, if the Last bit is set in buffer descriptor, the last byte pointer in HTxFIFO is also set. This means the last byte of the frame is in HTxFIFO. If the transmitted frame is longer than the Buffer Length field value, the last byte pointer will not be set, and the next buffer descriptor having the last byte pointer bit will be used.

The pointers continue shifting through the FIFO. When the transmitter detects a positive transition in the data valid pointer at the last location of the FIFO, it initiates a frame with an opening flag. When it detects a negative transition in the last byte pointer at the last location of the FIFO, it closes the frame, appending the CRC and a closing flag follows.

The status of the Tx FIFO is indicated by the transmitter FIFO register available (TxFA) status bit. When TxFA = '1', the Tx FIFO is available for loading data and data can be loaded into it. (This function is controlled by the Tx4WD bit.) The HTxFIFO is reset by writing a '1' to the Tx reset, or the TxABT bit or by the nRESET. During a reset operation, the TxFA status bit is suppressed and data loading is inhibited.

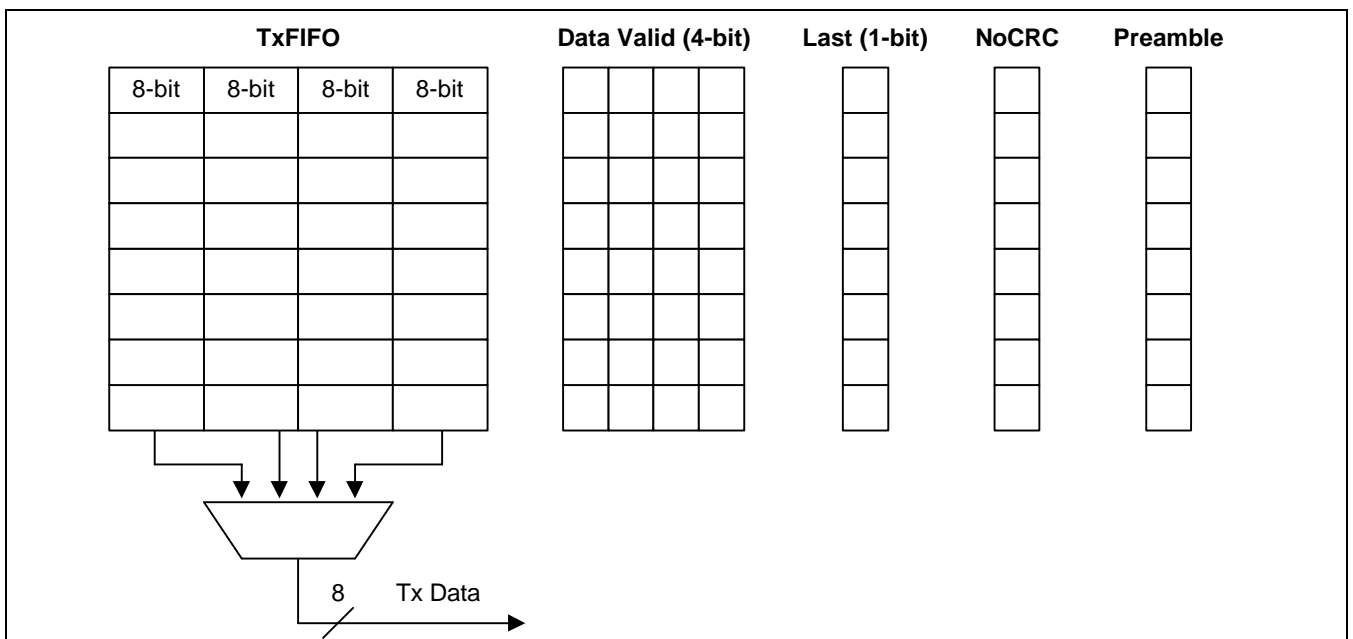

**Figure 8-19. HDLC Tx FIFO Function Diagram**

**HDLC RX FIFO (HRXFIFO)**

The Rx FIFO consists of eight 32-bit registers that are used for the buffer storage of the data received. Data bytes are always transferred from a full register to an adjacent empty register. Each register has pointer bits that indicate the frame status. When these pointers appear at the last 1-word or 4-word FIFO location, they update the LAST bit(indicating the last of a frame), the OVERRUN bit, the CRC error bit, or Non-octet aligned bit.

The HRXFIFO data available (RxFA) status bits indicate the current state of the HRXFIFO. When the HRXFIFO data status bit is '1', the HRXFIFO is ready to be read. The HRXFIFO data status is controlled by the 4-word or 1-word transfer selection bit (Rx4WD). When an overrun occurs, the overrun frame of the HRXFIFO is no longer valid.

An 'in frame' abort or a High level on nDCD input with the AutoEN bit in HCON is set to '1', the frame is cleared in the HRXFIFO. (The last byte of the previous frame, which is separated by the frame boundary pointer, is retained). Data in HRXFIFO should be read by word size.

The HRXFIFO is cleared by the Rx reset bit set to '1', an abort signal received, or nRESET.

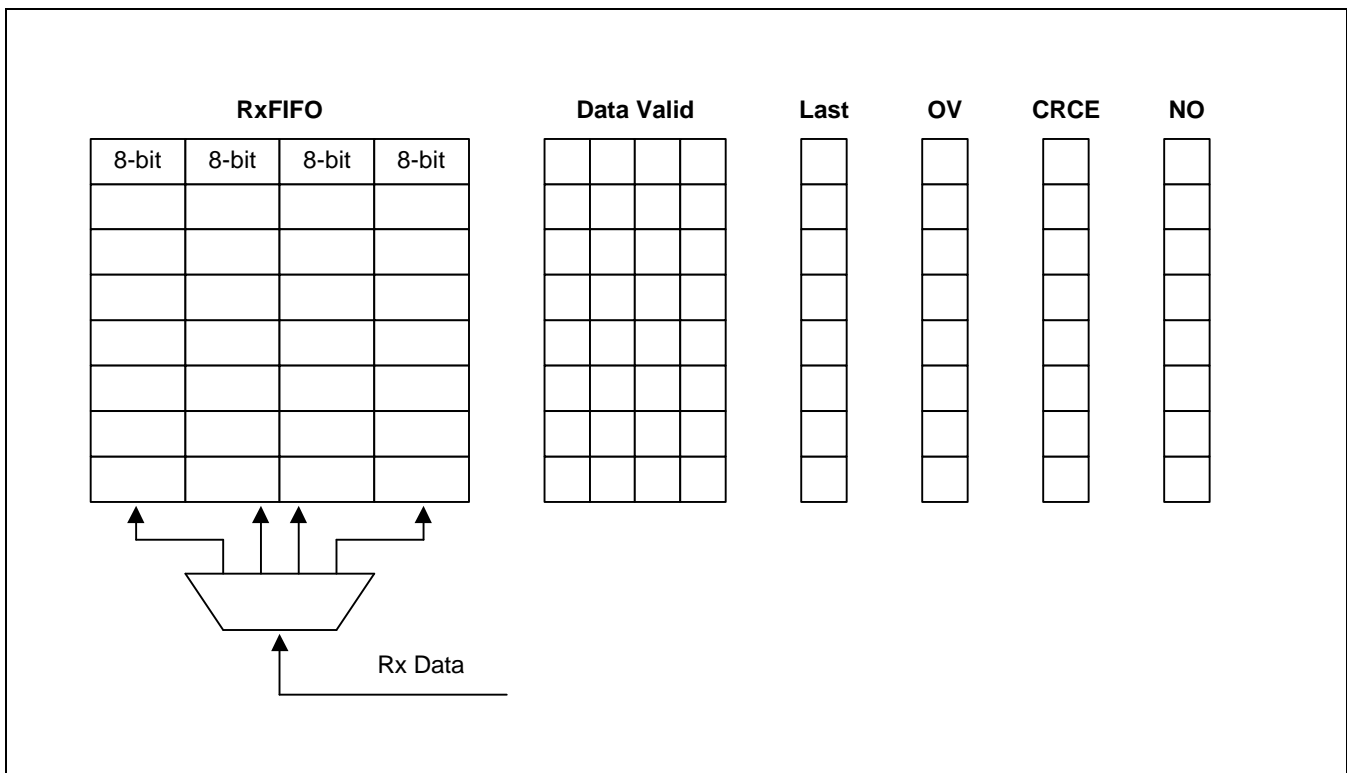

**Figure 8-20. HDLC Rx FIFO Function Diagram**

HDLC BRG TIME CONSTANT REGISTERS (HBRGTC)

Table 8-14. HBRGTCA and HBRGTCB Register

Registers	Offset	R/W	Description	Reset Value
HBRGTCA	0x701c	R/W	HDLC BRG Time Constant Register	0x00000000
HBRGTCB	0x801c	R/W	HDLC BRG Time Constant Register	0x00000000

The HDLC BRG time constant register value can be changed at any time, but the new value does not take effect until the next time the constant is loaded into the down counter. No attempt is made to synchronize the loading of the time constant into HBRGTC while the clock is driving the down counter. For this reason, you should first disable the baud rate generator before loading the new time constant into the HBRGTC register.

The formula for determining the appropriate time constant for a given baud rate is shown below. The desired rate is shown in bits per second. This formula shows how the counter decrements from N down to zero-plus-one cycles for reloading the time constant. This value is then fed to a toggle flip-flop to generate the square wave output.

$$BRGOUT1 = (MCLK2 \text{ or } RXC) / (CNT0 + 1) / (16^{CNT1})$$

$$BRGOUT2 = BRGOUT1 / (1 \text{ or } 16 \text{ or } 32 \text{ according to } CNT2 \text{ value of the HBRGTC})$$

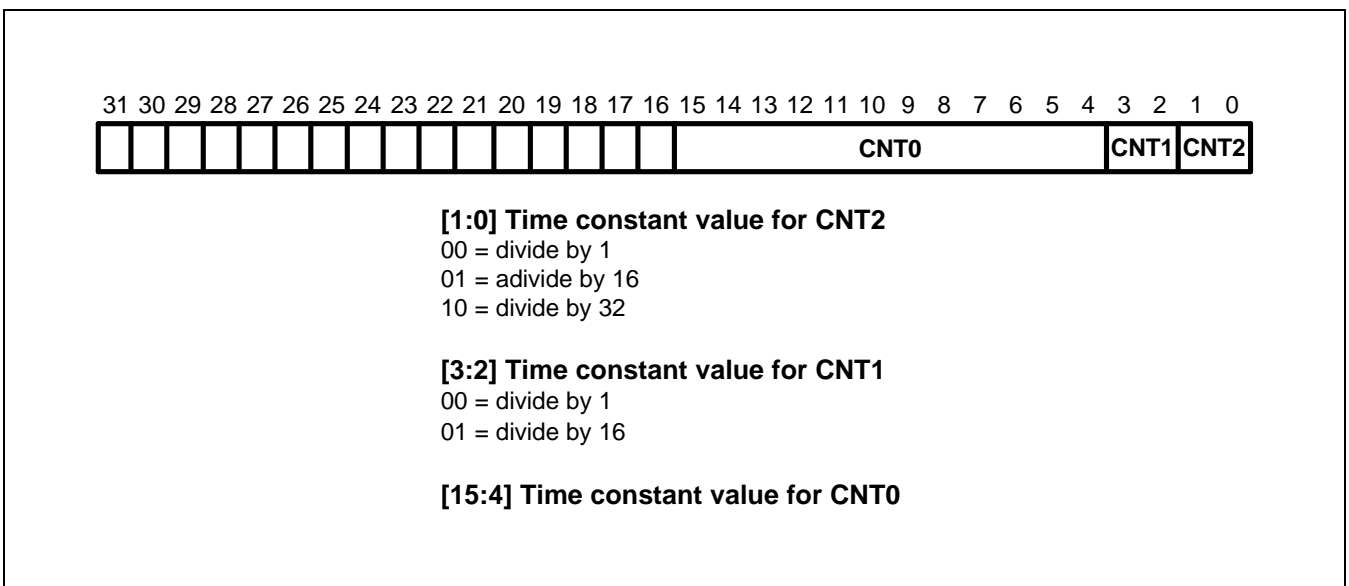

Figure 8-21. HDLC BRG Time Constant Register

**HDLC PREAMBLE CONSTANT REGISTER (HPRMB)**

The HPRMB register is used to meet the DPLL requirements for phase-locking. The preamble pattern is transmitted as many Tx preamble length bit values in HMODE[10:8] when the Tx preamble bit (TxPRMB) is '1', and then the Tx preamble bit is cleared automatically. The opening flag follows this preamble pattern, and the data will be transmitted.

**Table 8-15. HPRMBA and HPRMBB Register**

Registers	Offset	R/W	Description	Reset Value
HPRMBA	0x7020	R/W	HDLC Preamble Constant Register	0x00000000
HPRMBB	0x8020	R/W	HDLC Preamble Constant Register	0x00000000

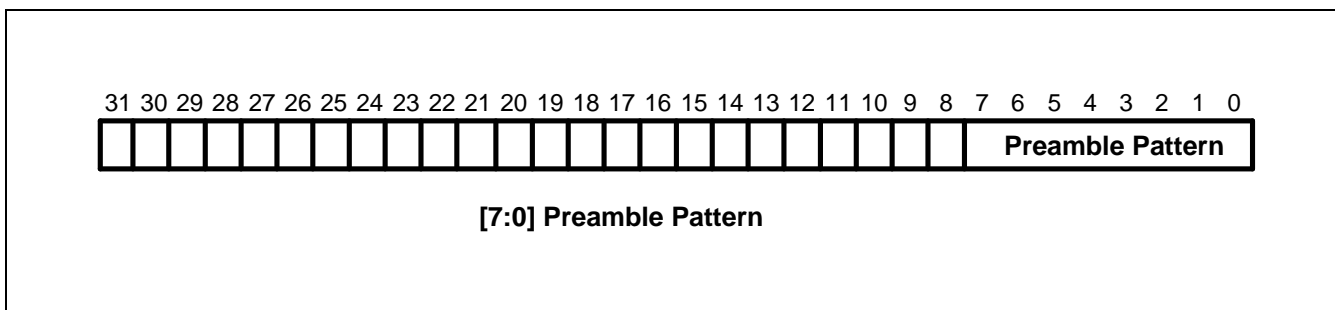

**Figure 8-22. HDLC Preamble Constant Register**

The reference for the preamble pattern of each data mode is as follows:

**Table 8-16. Preamble Reference Pattern**

Data Mode	Preamble Pattern
NRZ	AA
NRZI	00
FM0	FF
FM1	00
MANCHESTER	AA

### HDLC STATION ADDRESS REGISTERS (HSADR0–3) AND HMASK REGISTER

Each HDLC controller has five 32-bit registers for address recognition: four station address registers and one mask register. Generally, the HDLC controller reads the address of the frame from the receiver, to check it against the four station address values, and then masks the result with the user-defined HMASK register. A "1" in the HMASK register represents a bit position for which an address comparison should occur. A "0" represents a masked bit position. If you check the address up to four bytes, the HMASK register value should be 0xffffffff. Dependent on the HMASK register value, the frame's address is compared. If the address is not matched, this frame is discarded.

**Table 8-17. HSADR and HMASK Register**

Registers	Offset	R/W	Description	Reset Value
HSADR0A	0x7024	R/W	HDLC station address 0	0x00000000
HSADR1A	0x7028	R/W	HDLC station address 1	0x00000000
HSADR2A	0x702c	R/W	HDLC station address 2	0x00000000
HSADR3A	0x7030	R/W	HDLC station address 3	0x00000000
HMASKA	0x7034	R/W	HDLC address mask register	0x00000000
HSADR0B	0x8024	R/W	HDLC station address 0	0x00000000
HSADR1B	0x8028	R/W	HDLC station address 1	0x00000000
HSADR2B	0x802c	R/W	HDLC station address 2	0x00000000
HSADR3B	0x8030	R/W	HDLC station address 3	0x00000000
HMASKB	0x8034	R/W	HDLC address mask register	0x00000000

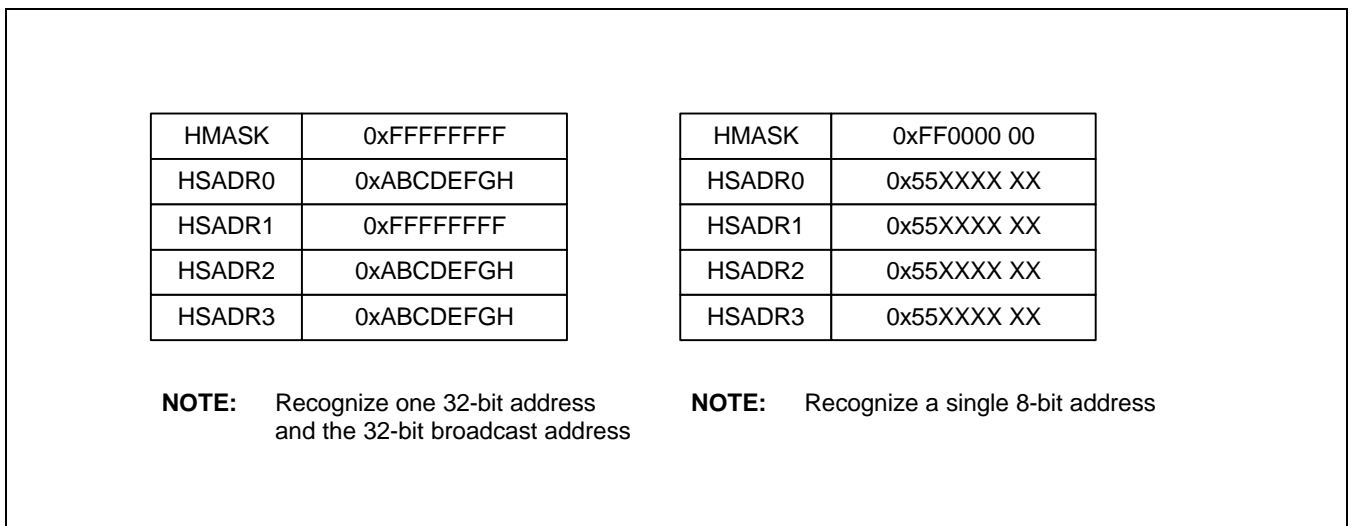

**Figure 8-23. Address Recognition**

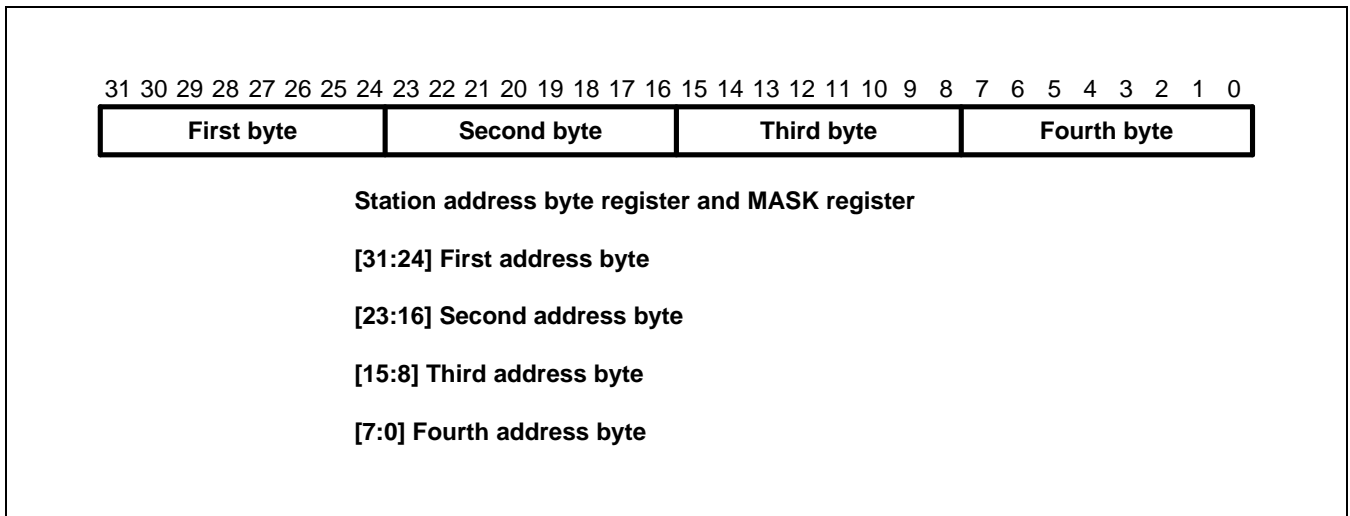

Figure 8-24. HDLC Station Address and HMASK Register

**DMA TX BUFFER DESCRIPTOR POINTER REGISTER**

The DMA transmit buffer descriptor pointer register contains the address of the Tx buffer data pointer on the data to be sent. During a DMA operation, the buffer descriptor pointer is updated by the next buffer data pointer.

Table 8-18. DMA Tx Buffer Descriptor Pointer Registers

Registers	Offset	R/W	Description	Reset Value
HDMATXPTRA	0x7038	R/W	DMA Tx Buffer Descriptor Pointer	0xFFFFFFFF
HDMATXPTRB	0x8038	R/W	DMA Tx Buffer Descriptor Pointer	0xFFFFFFFF

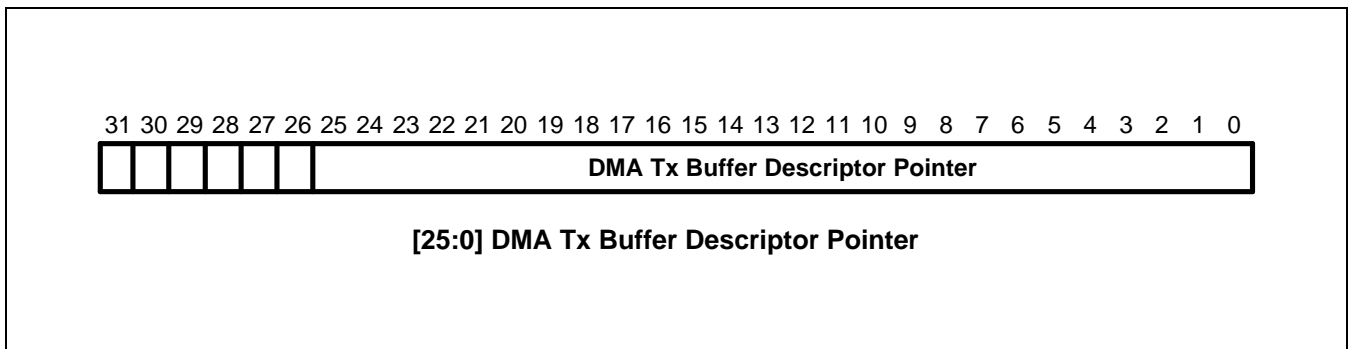

Figure 8-25. DMA Tx Buffer Descriptor Pointer

**DMA RX BUFFER DESCRIPTOR POINTER REGISTER**

The DMA receive buffer descriptor pointer register contains the address of the Rx buffer data pointer on the data to be received. During a DMA operation, the buffer descriptor pointer is updated by the next buffer data pointer.

**Table 8-19. DMA Rx Buffer Descriptor Pointer Registers**

Registers	Offset	R/W	Description	Reset Value
HDMARXPTRA	0x703c	R/W	DMA Rx Buffer Descriptor Pointer	0xFFFFFFFF
HDMARXPTRB	0x803c	R/W	DMA Rx Buffer Descriptor Pointer	0xFFFFFFFF

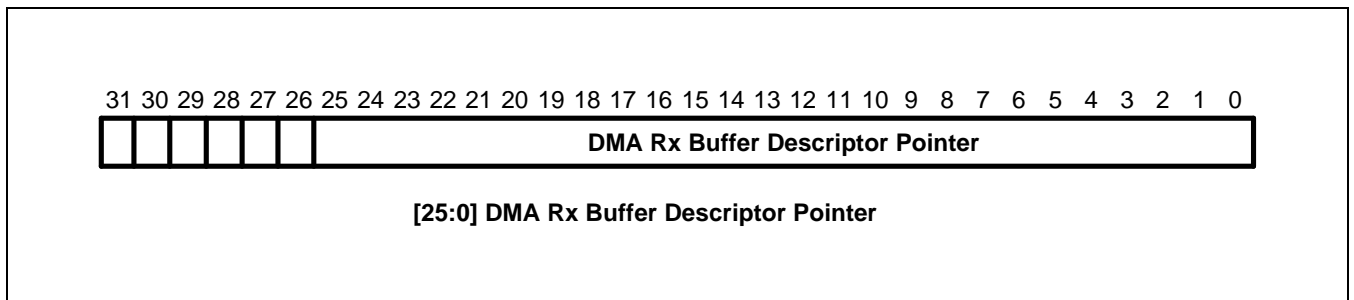

**Figure 8-26. DMA Rx Buffer Descriptor Pointer**

**MAXIMUM FRAME LENGTH REGISTER**

The HDLC controller checks the length of an incoming frame against the user-defined value in DMA mode. If the frame received exceeds this register value, the frame is discarded, and FLV(Frame Length Violated) bit is set in the buffer descriptor belonging to that frame.

**Table 8-20. HDMATXCNT and HDMARXCNT Registers**

Registers	Offset	R/W	Description	Reset Value
HMFLRA	0x7040	R/W	Maximum Frame Length	0xFFFF0000
HMFLRB	0x8040	R/W	Maximum Frame Length	0xFFFF0000

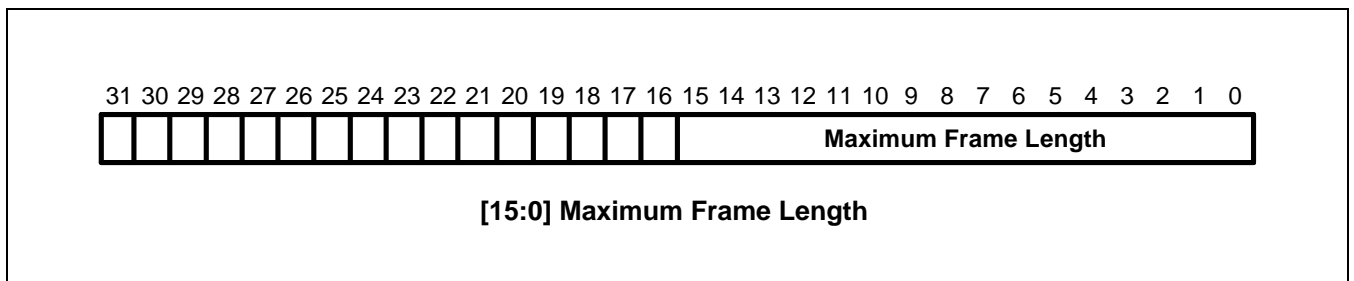

**Figure 8-27. Maximum Frame Length Register**

**RECEIVE BUFFER SIZE REGISTER**

The Rx buffer size register contains the 16-bit user-defined value. This user-defined count value determines the buffer size for one Buffer Descriptor. If incoming HDLC frame is longer than the Rx buffer size register value, the next buffer descriptor having the Rx buffer size value will be used.

**Table 8-21. DMA Rx Buffer Size Register**

Registers	Offset	R/W	Description	Reset Value
HRBSRA	0x7044	R/W	Receive Buffer Size Register	0xFFFF0000
HRBSRB	0x8044	R/W	Receive Buffer Size Register	0xFFFF0000

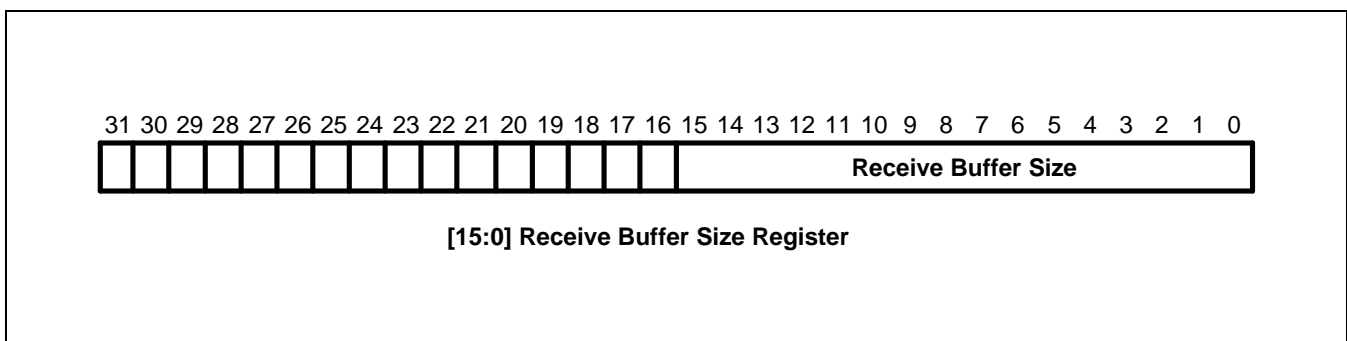

**Figure 8-28. DMA Receive Buffer Size Register**



# 9 DMA CONTROLLER

## OVERVIEW

The S3C4510B has a two-channel general DMA controller, called the GDMA. The two-channel GDMA performs the following data transfers without CPU intervention:

- Memory-to-memory (memory to/from memory)
- UART-to-memory (serial port to/from memory)

The on-chip GDMA can be started by software and/or by an external DMA request (nXDREQ). Software can also be used to restart a GDMA operation after it has been stopped.

The CPU can recognize when a GDMA operation has been completed by software polling and/or when it receives an appropriate internally generated GDMA interrupt. The S3C4510B GDMA controller can increment or decrement source or destination addresses and conduct 8-bit (byte), 16-bit (half-word), or 32-bit (word) data transfers.

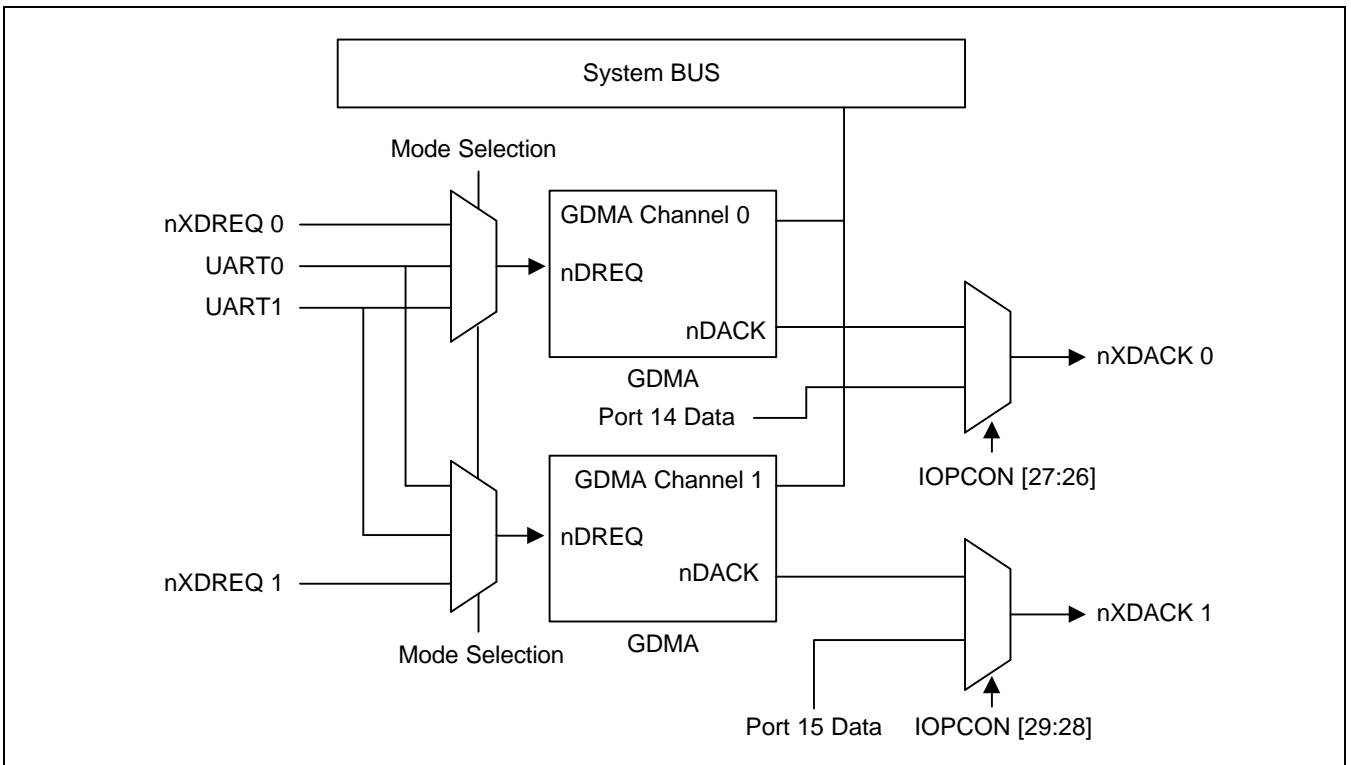

Figure 9-1. GDMA Controller Block Diagram

## GDMA SPECIAL REGISTERS

**Table 9-1. GDMA Special Registers Overview**

Registers	Offset	R/W	Description	Reset Value
GDMACON0	0xB000	R/W	GDMA controller channel 0 control register	0x00000000
GDMACON1	0xC000	R/W	GDMA controller channel 1 control register	0x00000000
GDMASRC0	0xB004	R/W	GDMA channel 0 source address register	Undefined
GDMADST0	0xB008	R/W	GDMA channel 0 destination address register	Undefined
GDMASRC1	0xC004	R/W	GDMA channel 1 source address register	Undefined
GDMADST1	0xC008	R/W	GDMA channel 1 destination address register	Undefined
GDMACNT0	0xB00C	R/W	GDMA channel 0 transfer count register	Undefined
GDMACNT1	0xC00C	R/W	GDMA channel 1 transfer count register	Undefined

## GDMA CONTROL REGISTERS

**Table 9-2. GDMACON0 and GDMACON1 Registers**

Registers	Offset	R/W	Description	Reset Value
GDMACON0	0xB000	R/W	GDMA controller channel 0 control register	0x00000000
GDMACON1	0xC000	R/W	GDMA controller channel 1 control register	0x00000000

**Table 9-3. GDMA Control Register Description**

Bit Number	Bit Name	Reset Value
[0]	Run enable/disable	Setting this bit to "1", starts a DMA operation. To stop DMA, you must clear this bit to "0". You can use the GMA run bit control address (GDMACON offset address + 0x20) to manipulate this bit. By using the run bit control address, other GDMA control register values are not affected.
[1]	Busy status	When DMA starts, this read-only status bit is automatically set to "1". When it is "0", DMA is idle.
[3:2]	GDMA mode selection	Four sources can initiate a DMA operation: 1) software (memory-to-memory), 2) an external DMA request (nXDREQ), 3) the UART0 block, and 4) the UART1 block. The mode selection setting determines which source can initiate a DMA operation at any given time.
[4]	Destination address direction	This bit controls whether the destination address will be decremented ("1") or incremented ("0") during a DMA operation.
[5]	Source address direction	This bit controls whether the source address will be decremented ("1") or incremented ("0") during a DMA operation.

Table 9-3. GDMA Control Register Description (Continued)

Bit Number	Bit Name	Reset Value
[6]	Destination address fix	This bit determines whether or not the destination address will be changed during a DMA operation. You use this feature when transferring data from multiple sources to a single destination.
[7]	Source address fix	This bit determines whether or not the source address will be changed during a DMA operation. You use this feature when transferring data from a single source to multiple destinations.
[8]	Stop interrupt enable	To start/stop a DMA operation, you set/clear the run enable bit. If the stop interrupt enable bit is "1" when DMA starts, a stop interrupt is generated when DMA operation stops. If this bit is "0", the stop interrupt is not generated.
[9]	Four-data burst enable	If this bit is set to one, GDMA operates under 4-data burst mode. under the 4-data burst mode, 4 consecutive source addresses are read and then are written to the consecutive destination addresses. If 4-data burst mode is set to one, "transfer count register" should be set carefully because the 4-data burst move is executed during decreasing of the transfer count. The 4-data burst mode can be used only when GMDA mode is software or external DMA request mode.
[10]	Peripheral direction	This bit is used to specify the direction of a DMA operation when the mode bits [3:2] are set to '10' (UART0 from/to memory) or '11' (UART1 from/to memory). If this bit is "1", DMA operates in the memory-to-peripheral direction (e.g., to the parallel port or UART). When it is "0", DMA operates in the peripheral-to-memory direction.
[11]	Single/Block mode	This bit determines the number of external DMA requests (nXDREQs) that are required for a DMA operation. In Single mode, when [11] = "0", the S3C4510B requires an external DMA request for every DMA operation. In Block mode, when [11] = "1", the S3C4510B requires only one external DMA request during the entire DMA operation. An entire DMA operation is defined as the operation of DMA until the counter value is zero. <b>NOTE:</b> You should not use block mode together with demand mode, or single mode in conjunction with continuous mode.
[13:12]	Transfer width	These bits determine the transfer data width to be one byte, one half-word, or one word. If you select a byte transfer operation, the source/destination address will be incremented or decremented by one with each transfer. Each half-word transfer increments or decrements the address by two, and each word transfer by four.
[14]	Continuous mode	This bit lets the DMA controller hold the system bus until the DMA transfer count value is zero. You must therefore manipulate this bit carefully so that DMA transfer operations do not exceed a acceptable time interval (as, for example, in a DRAM refresh operation). <b>NOTE:</b> You can use continuous mode together with a software request mode.

Table 9-3. GDMA Control Register Description (Continued)

Bit Number	Bit Name	Reset Value
[15]	Demand mode	<p>Setting this bit speeds up external DMA operations. When [15]="1", the DMA transfers data when the external DMA request signal (nXDREQ) is active. The amount of data transferred depends on how long nXDREQ is active. When nXDREQ is active and DMA gets the bus in Demand mode, DMA holds the system bus until the nXDREQ signal becomes non-active. Therefore, the period of the active nXDREQ signal should be carefully timed so that the entire operation does not exceed an acceptable interval (as, for example, in a DRAM refresh operation).</p> <p><b>NOTE:</b> In demand mode, you must clear the single/block and continuous mode control bits to "0".</p>

**NOTE:** To ensure the reliability of DMA operations, the GDMA control register bits must be configured independently and carefully.

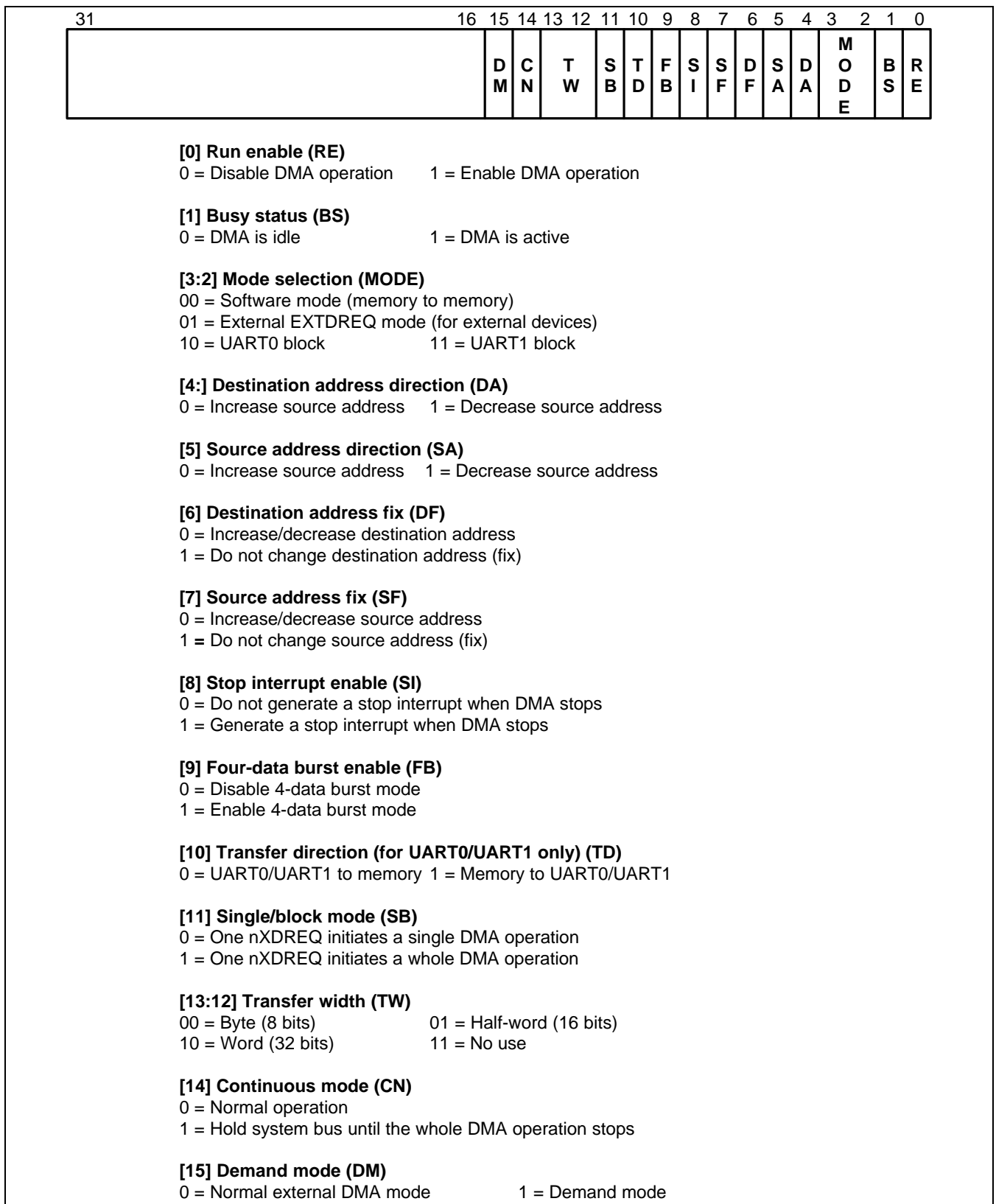

Figure 9-2. GDMA Control Register

## GDMA SOURCE/DESTINATION ADDRESS REGISTERS

The GDMA source/destination address registers contain the 26-bit source/destination addresses for GDMA channels 0 and 1. Depending on the settings you make to the GDMA control register (GDMACON), the source or destination addresses will either remain the same, or they will be incremented or decremented.

**Table 9-4. GDAMSRC0/1 and GDMADST0/1 Registers**

Registers	Offset	R/W	Description	Reset Value
GDMA_SRC0	0xB004	R/W	GDMA channel 0 source address register	Undefined
GDMADST0	0xB008	R/W	GDMA channel 0 destination address register	Undefined
GDMA_SRC1	0xC004	R/W	GDMA channel 1 source address register	Undefined
GDMADST1	0xC008	R/W	GDMA channel 1 destination address register	Undefined

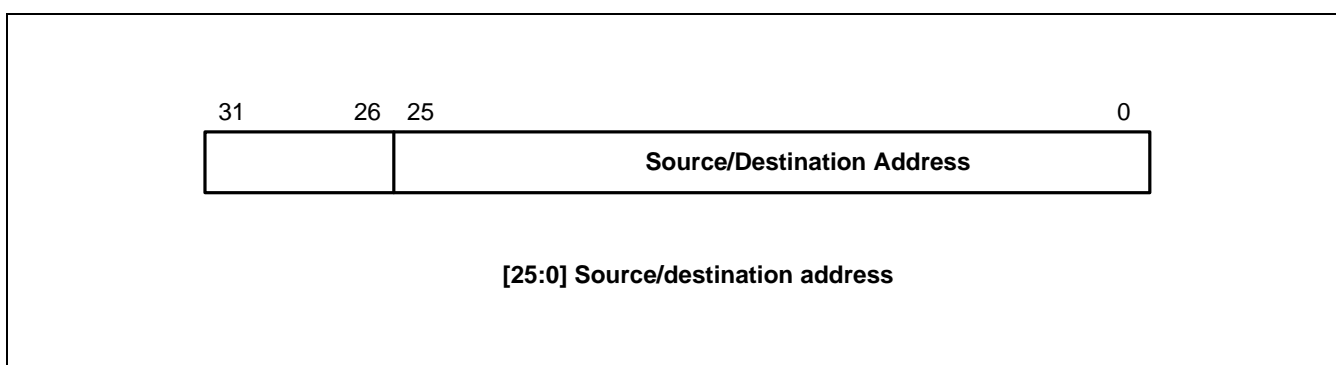

**Figure 9-3. GDMA Source/Destination Address Register**

## DMA TRANSFER COUNT REGISTERS

The DMA transfer count registers contain the 24-bit current count value of the number of DMA transfers completed for GDMA channels 0 and 1.

The count value is always decremented by one for each completed DMA operation, regardless of the GDMA data transfer width or four-data burst mode.

### NOTE

At the 4-data burst mode, actual transfer data size will be "Transfer Count x4."

**Table 9-5. GDMACNT0/1 Registers**

Registers	Offset	R/W	Description	Reset Value
GDMACNT0	0xB00C	R/W	GDMA channel 0 transfer count register	Undefined
GDMACNT1	0xC00C	R/W	GDMA channel 1 transfer count register	Undefined

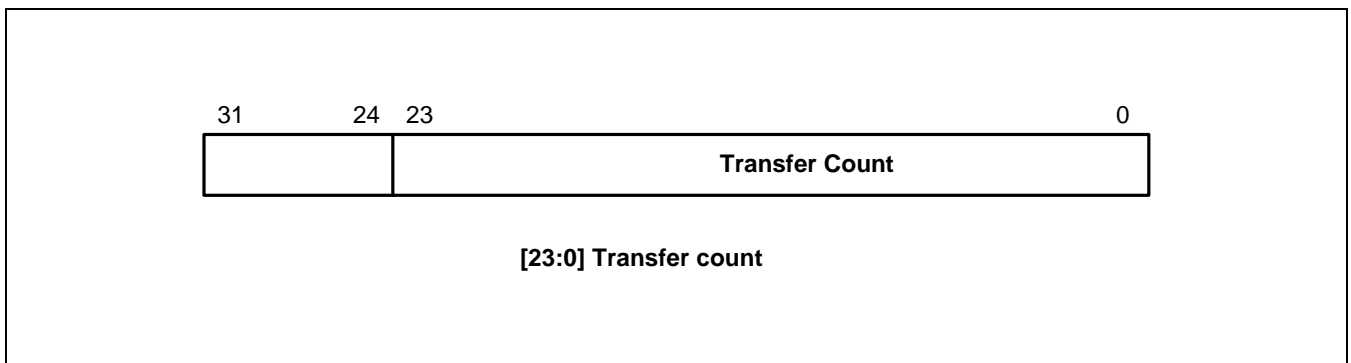

**Figure 9-4. DMA Transfer Count Register**

## GDMA FUNCTION DESCRIPTION

The following sections provide a functional description of the GDMA controller operations.

### GDMA TRANSFERS

The GDMA transfers data directly between a requester and a target. The requester and target are memory, UART or external devices. An external device requests GDMA service by activating nXDREQ signal. A channel is programmed by writing to registers which contain requester address, target address, the amount of data, and other control contents. UART, external I/O, or Software(memory) can request GDMA service. UART is internally connected to the GDMA.

### STARTING/ENDING GDMA TRANSFERS

GDMA starts to transfer data after the GDMA receives service request from nXDREQ signal, UART, or Software. When the entire buffer of data has been transferred, the GDMA becomes idle. If you want to preform another buffer transfer, the GDMA must be reprogrammed. Although the same buffer transfer wii be preformed again, the GDMA must be reprogrammed.

### DATA TRANSFER MODES

#### Single Mode

A GDMA request (nXDREQ or an internal request) causes one byte, one half-word, or one word to be transmitted if 4-data burst mode is disable state, or four times of transfer width if 4-data burst mode is enable state. Single mode requires a GDMA request for each data transfer. The nXDREQ signal can be de-asserted after checking that nXDACK has been asserted.

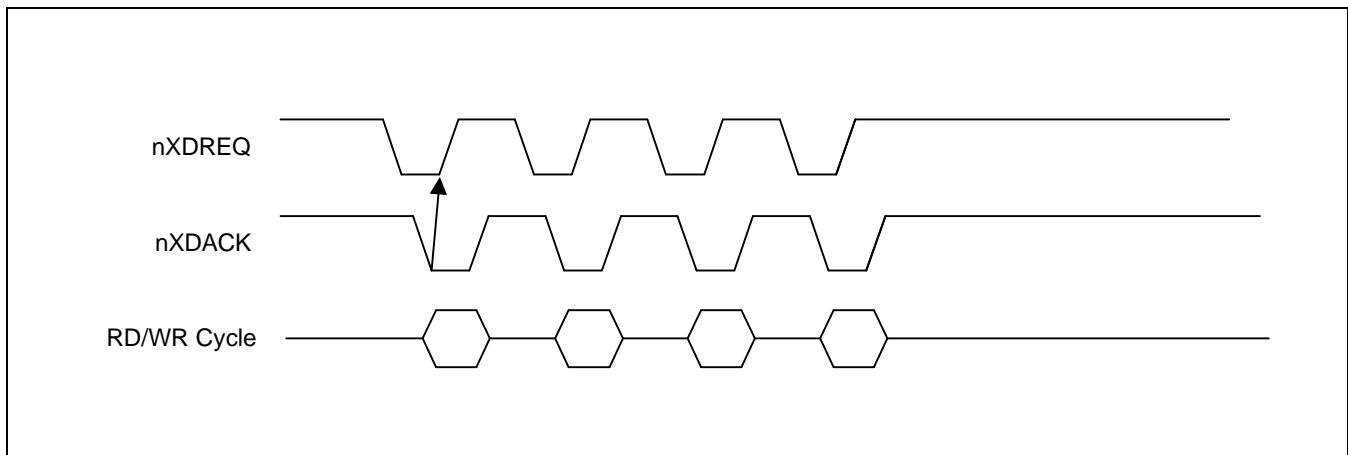
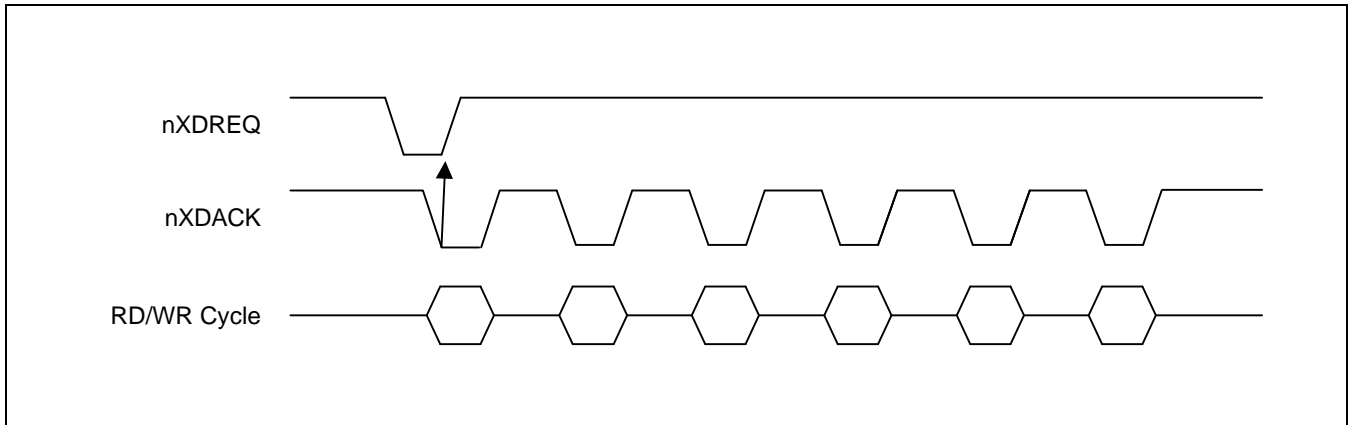

Figure 9-5. External DMA Requests (Single Mode)



**Block Mode**

The assertion of only one GDMA request (nXDREQ or an internal request) causes all of the data, as specified by the control register settings, to be transmitted in a single operation. The GDMA transfer is completed when the transfer counter value reaches zero. The nXDREQ signal can be de-asserted after checking that nXDACK has been asserted.



**Figure 9-6. External DMA Requests (Block Mode)**

**Demand Mode**

In demand mode, the GDMA continues transferring data as long as the GDMA request input (nXDREQ) is held active.

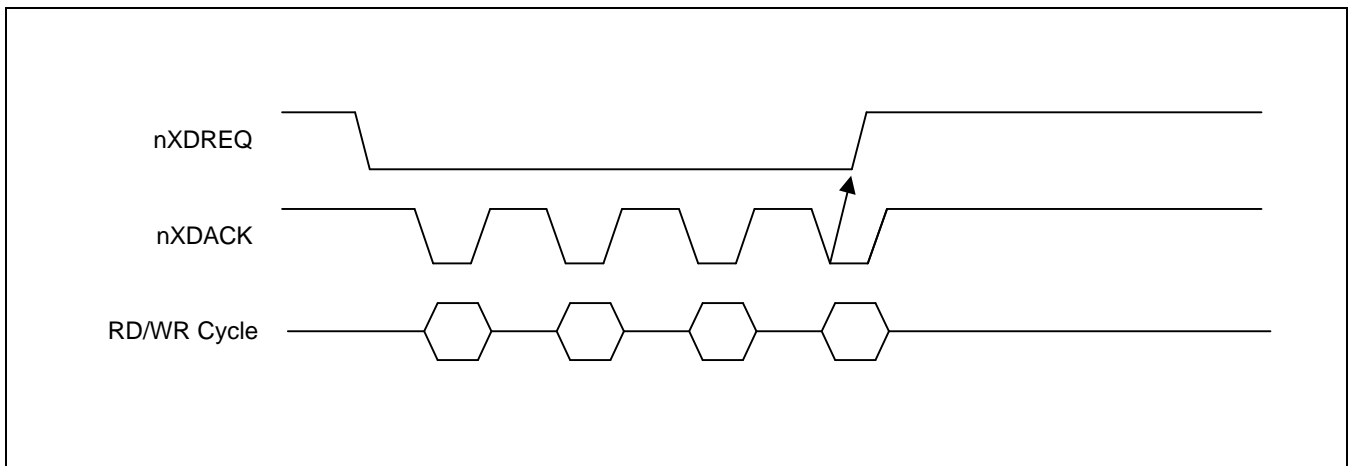
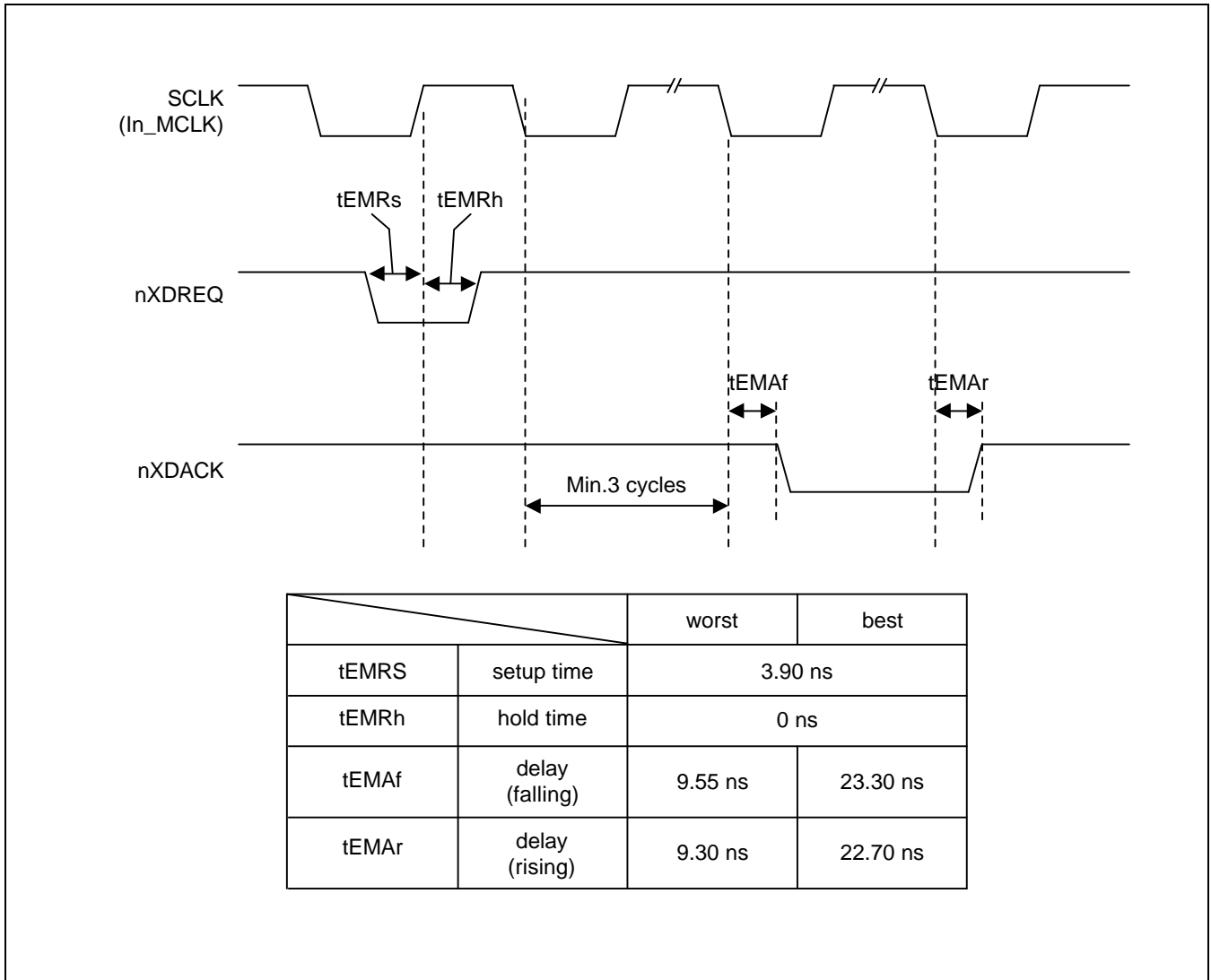

**Figure 9-7. External DMA Requests (Demand Mode)**

**DMA TRANSFER TIMING DATA**

Figure 9-8 provides detailed timing data for GDMA data transfers that are triggered by external DMA requests. Please note that read/write timing depends on which memory banks are selected.

To access ROM banks, which is in multiplexing bus mode, by 4-data burst mode, refer to Figure A-1 and Figure A-2 of appendix A for read/write timing of ROM bank 5.



**Figure 9-8. External DMA Requests Detailed Timing (S3C4510X)**

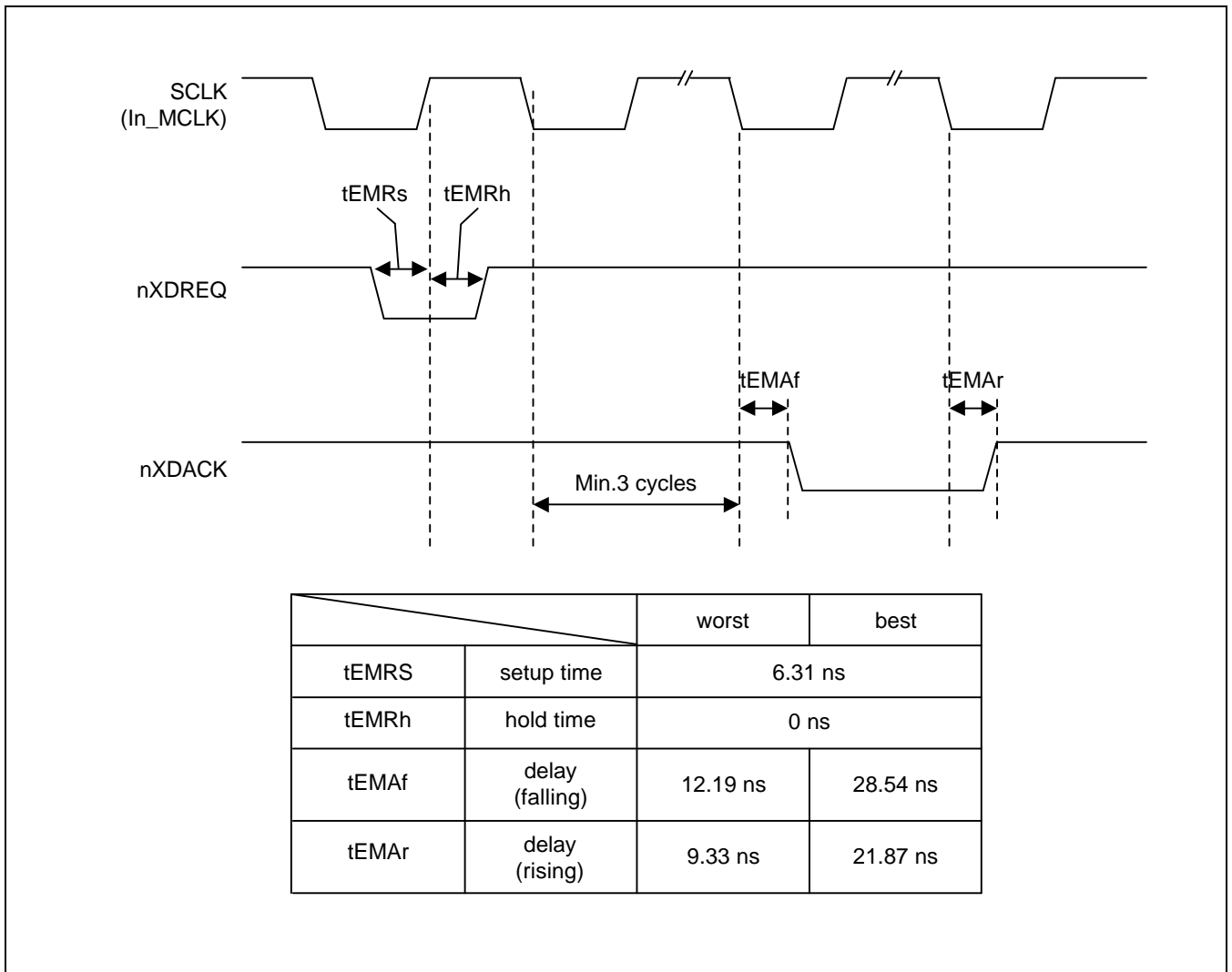
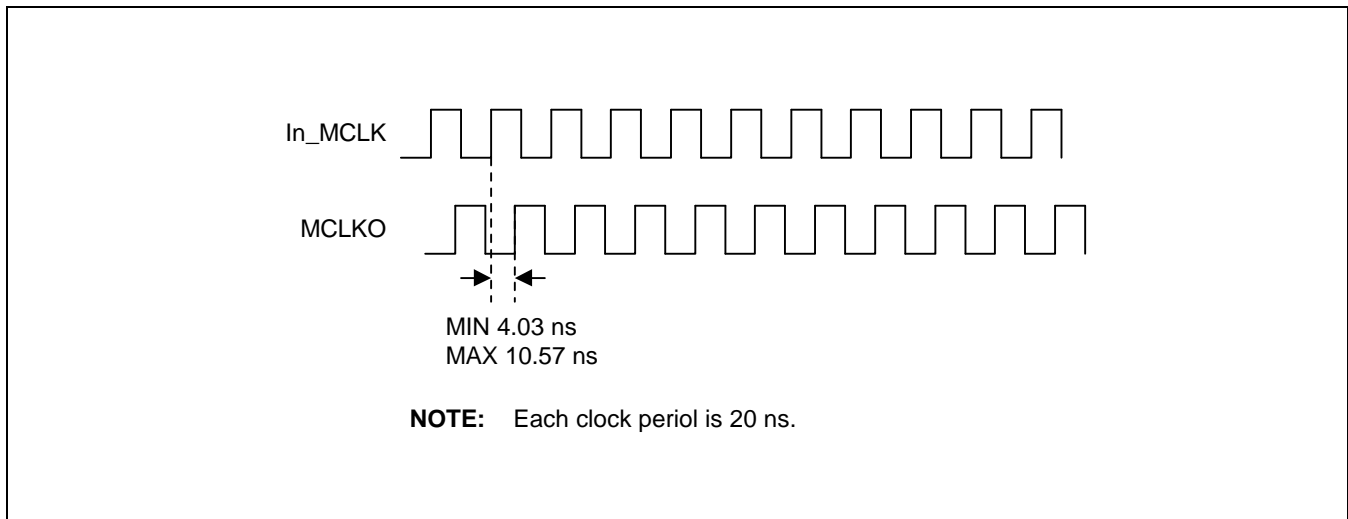

Figure 9-9. External DMA Requests Detailed Timing (S3C4510B)

**CLOCK DESCRIPTION**

The internal clock(In\_MCLK; This is the operating clock on the S3C4510B) differs from mclko(pad out clock). For more clear description, internal clock(In\_MCLK) is used at this timing diagram. Following Figure 9-9 is the relationship of internal clock(In\_MCLK) and mclko(pad out clock). You must think one more step that is the concern with mclko.



**Figure 9-10. MCLKO and SCLK (In\_MCLK)**

**SINGLE AND ONE DATA BURST MODE (GDMACON[11] = 0, [9] = 0 )**

DREQ and DACK signals are active low.

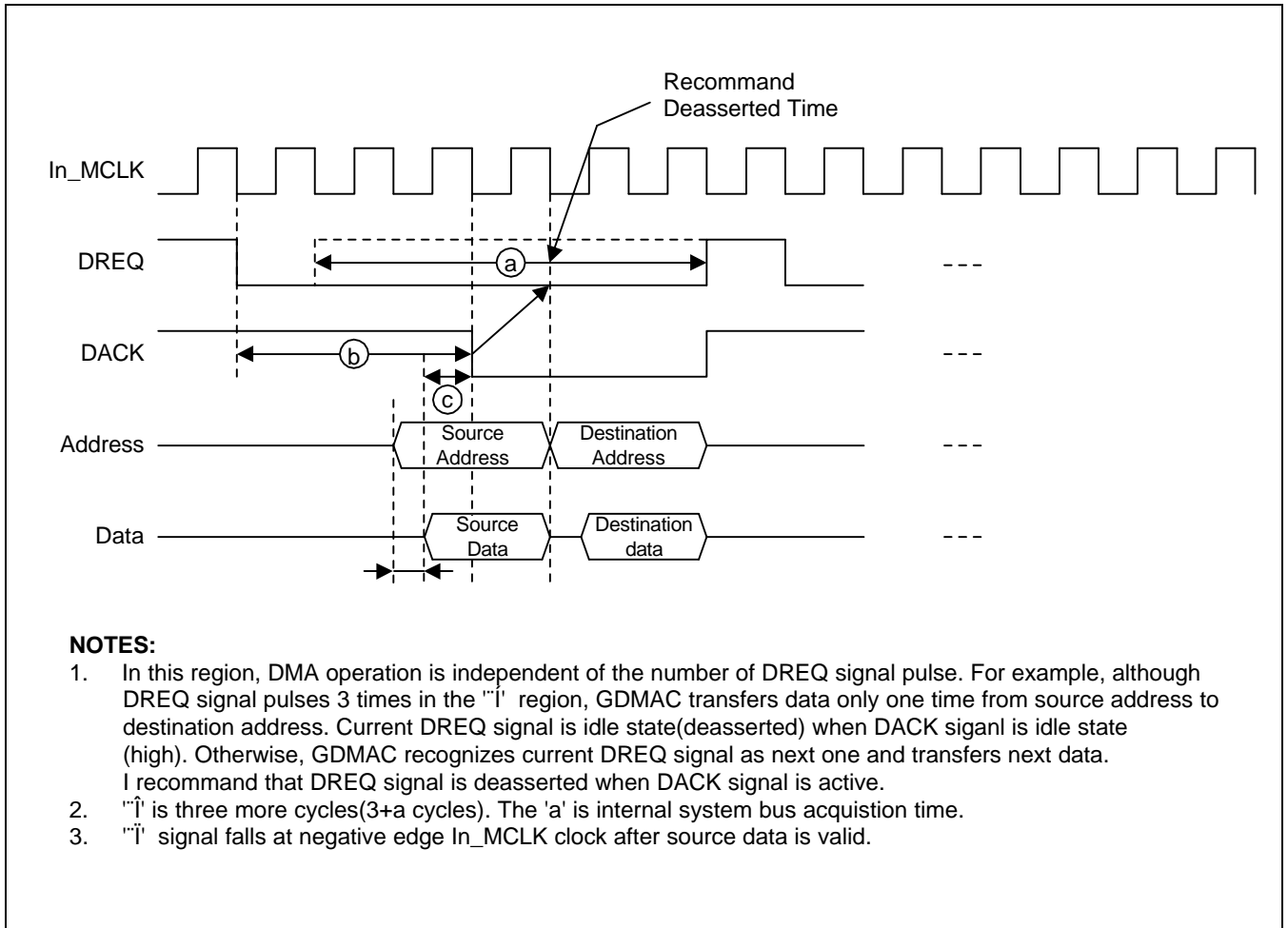
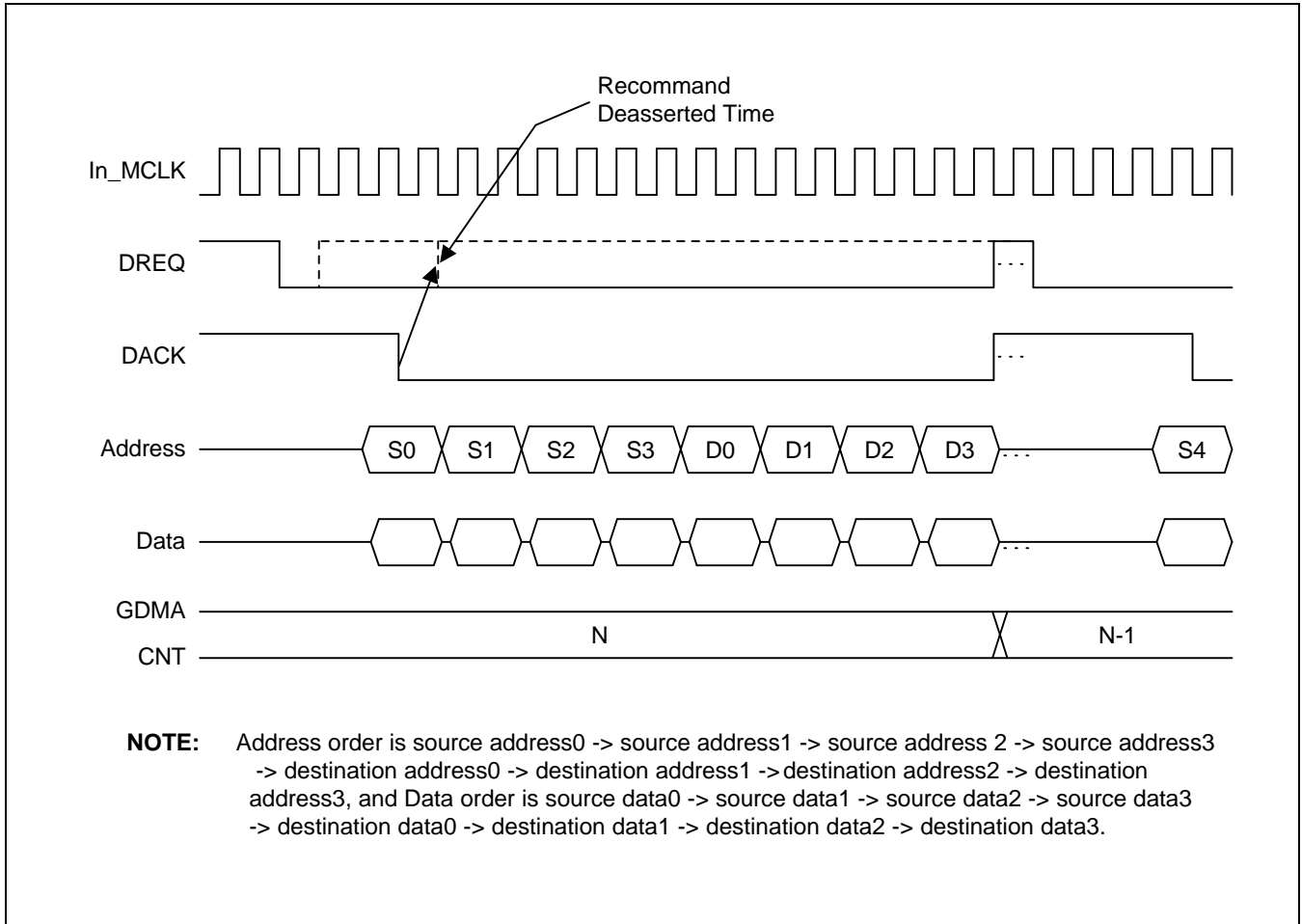

**Figure 9-11. Single and One Data Burst Mode Timing**

**SINGLE AND FOUR DATA BURST MODE (GDMA CON[11] = 0, [9] = 1 )**

DREQ & DACK signals are active low.

In the four data burst mode, GDMA COUNT Register(GDMA CNT) value decreases by 1 after 4 data transfer.

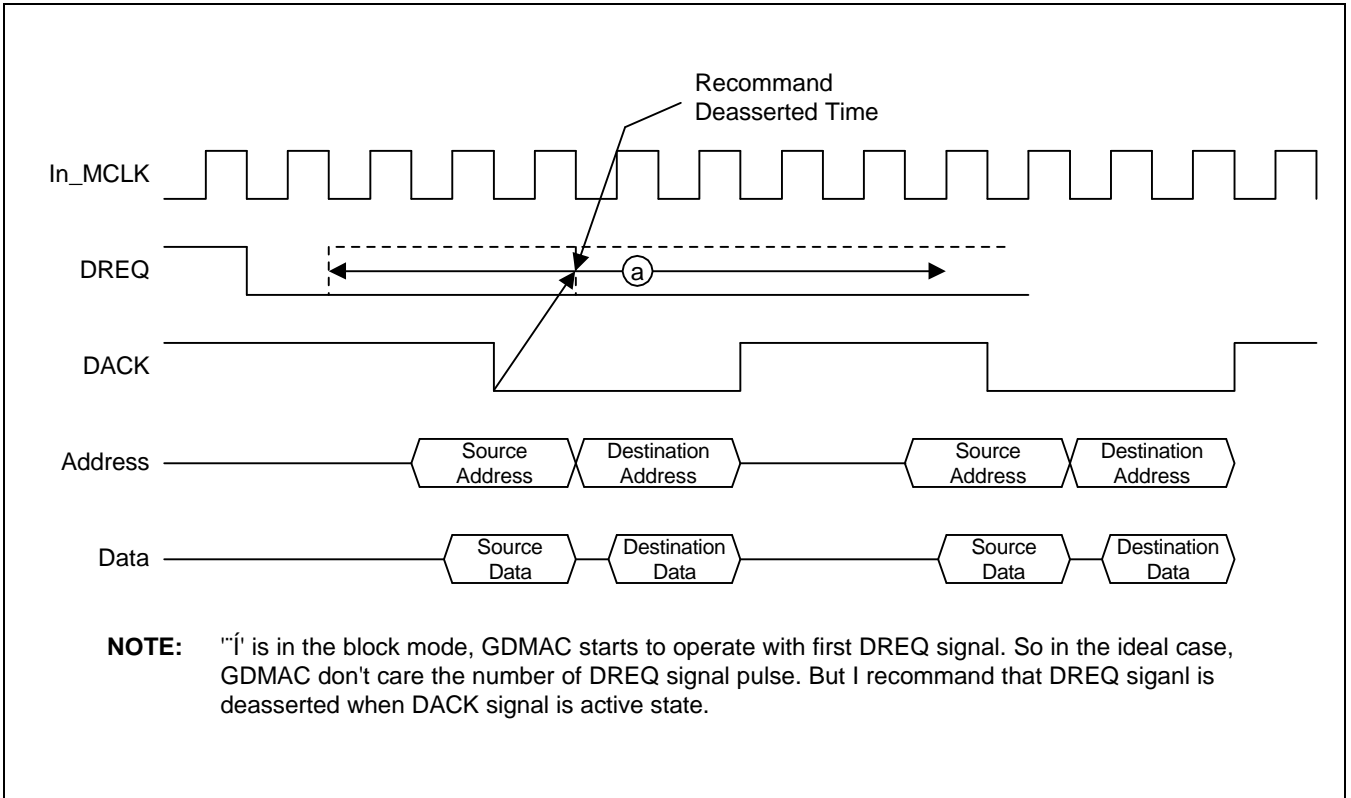

**Figure 9-12. Single and Four Data Burst Mode Timing**

**BLOCK AND ONE DATA BURST MODE (GDMACON[11] = 1, [9] = 0 )**

DREQ and DACK signals are active low.

GDMA transfers data from DREQ signal is active till GDMA COUNT Register consumes.



**Figure 9-13. Block and One Data Burst Mode Timing**

**BLOCK AND FOUR DATA BURST (GDMACON[11] = 1, [9] = 1 )**

This timing diagram is the same with Single and one data burst exception four data burst.

one data burst; source address0 and source data0 → destination address0 and destination data0 → ....

four data burst; source address0 and source data0 → source address1 and source data1 → source address2 and source data2 → source address3 and source data3 → destination address0 and destination data0 → destination address1 and destination data1 → destination address2 and destination data2 → destination address3 and destination data3 → source address4 and source data4 → ....

**NOTE**

In the four data burst mode, GDMA COUNT Register value decreases by 1 after 4 data transfer.

**CONTINUOUS AND ONE BURST MODE (GDMACON[14] = 1, [9] = 0)**

DREQ and DACK signals are active low.

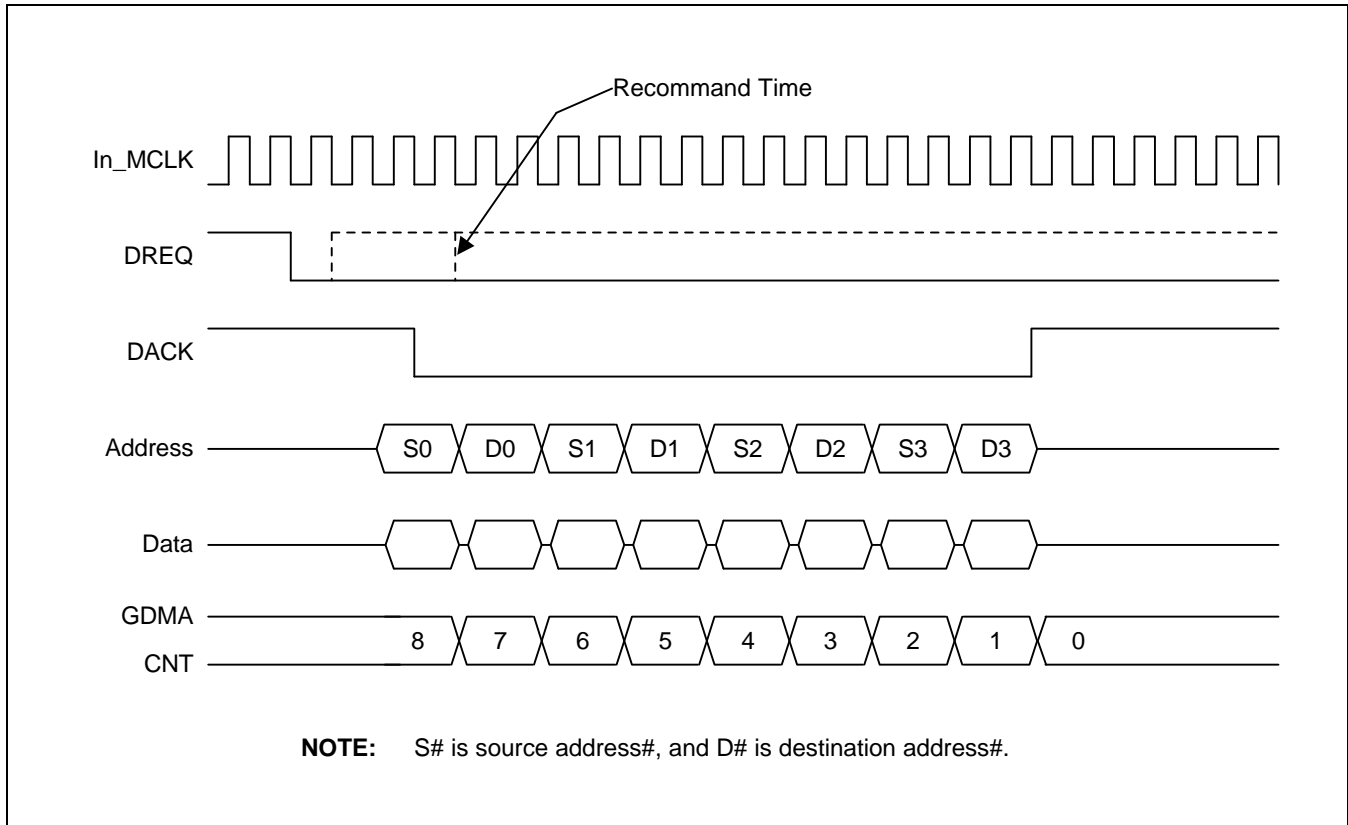

**Figure 9-14. Continuous and One Burst Mode Timing**

**CONTINUOUS AND FOUR DATA BURST MODE (GDMACON[14] = 1, [9] = 1)**

This timing diagram is the same with Continuous and one data burst exception four data burst.

one data burst; source address0 and source data0 → destination address0 and destination data0 → source address1 and source data1 → destination address1 and destination data1 → ...

four data burst; source address0 and source data0 → source address1 and source data1 → source address2 and source data2 → source address3 and source data3 → destination address0 and destination data0 → destination address1 and destination data1 → destination address2 and destination data2 → destination address3 and destination data3 → ...

**NOTE**

In the four data burst mode, GDMA COUNT Register value decreases by 1 after 4 data transfer.



**DEMAND AND ONE DATA BURST MODE (GDMACON[15] = 1, [9] = 0 )**

DREQ and DACK signals are active low.

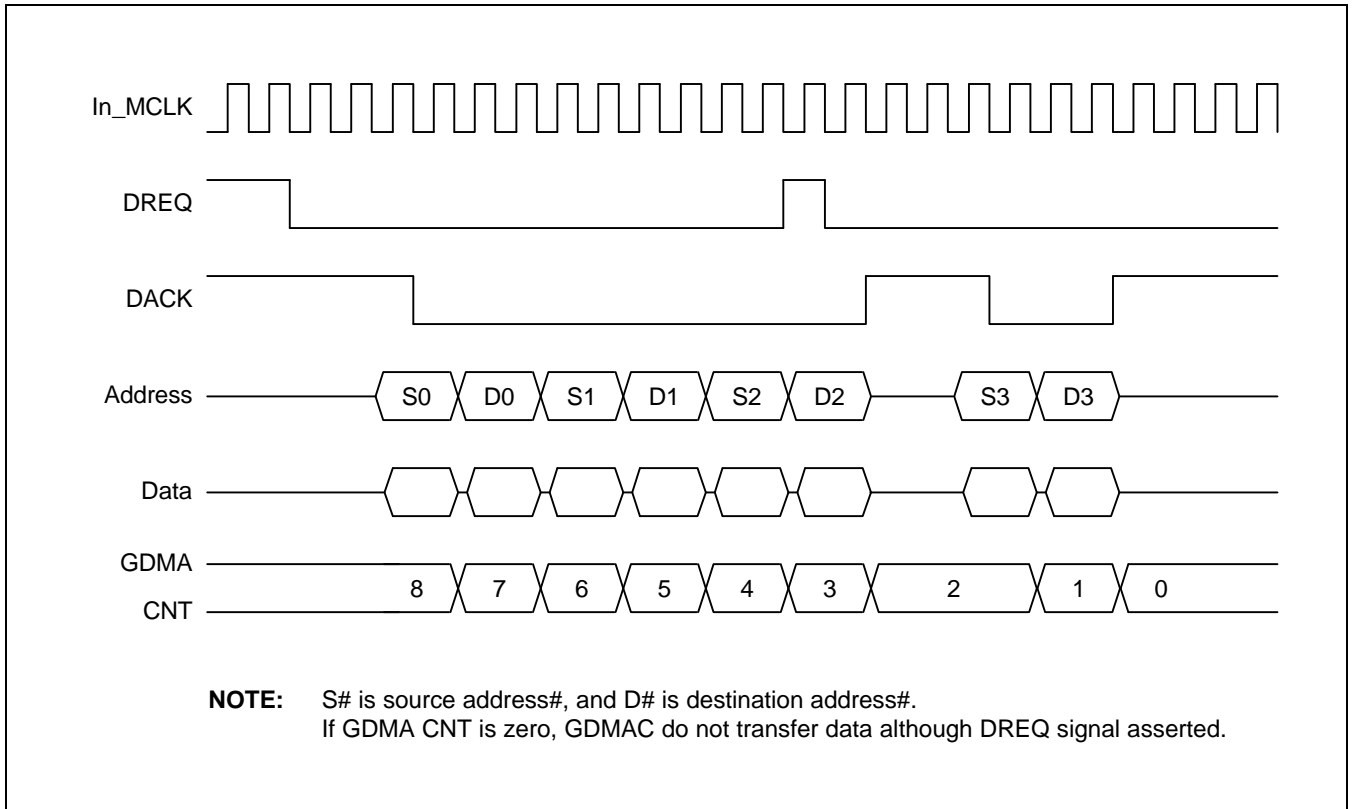

**Figure 9-15. Demand and One Data Burst Mode Timing**

**DEMAND & FOUR DATA BURST MODE ( GDMACON[15] = 1, [9] = 1 )**

This timing diagram is the same with Demand & one data burst exception four data burst.

one data burst; source address0 and source data0 → destination address0 and destination data0 → ...

four data burst; source address0 and source data0 → source address1 and source data1 → source address2 and source data2 → source address3 and source data3 → destination address0 and destination data0 → destination address1 and destination data1 → destination address2 and destination data2 → destination address3 and destination data3 → ...

**NOTE**

If you want to use continuous mode, you must set block mode not single mode.  
If you want to use demand mode, you must set single mode not block mode.

## NOTES

# 10 SERIAL I/O (UART)

## OVERVIEW

The S3C4510B UART (Universal Asynchronous Receiver/Transmitter) unit provides two independent asynchronous serial I/O (SIO) ports. Each port can operate in interrupt-based or DMA-based mode. That is, the UART can generate internal interrupts or DMA requests to transfer data between the CPU and the serial I/O ports.

The most important features of the S3C4510B UART include:

- Programmable baud rates
- Infra-red (IR) transmit/receive
- Insertion of one or two Stop bits per frame
- Selectable 5-bit, 6-bit, 7-bit, or 8-bit data transfers
- Parity checking

Each SIO unit has a baud rate generator, transmitter, receiver, and a control unit, as shown in Figure 10-1. The baud-rate generator can be driven by the internal system clock, MCLK, or by the external clock, UCLK. The transmitter and receiver blocks have independent data buffer registers and data shifters.

Transmit data is written first to the transmit buffer register. From there, it is copied to the transmit shifter and then shifted out by the transmit data pin, UATXDn. Receive data is shifted in by the receive data pin, UARXDn. It is then copied from the shifter to the receive buffer register when one data byte has been received.

The SIO control units provide software controls for mode selection, and for status and interrupt generation.

### NOTE

For the UART Tx interrupt method, you should write dummy byte to UART Tx buffer register before initialize UART. With this, you can generate UART Tx interrupt when Tx Buffer empty.

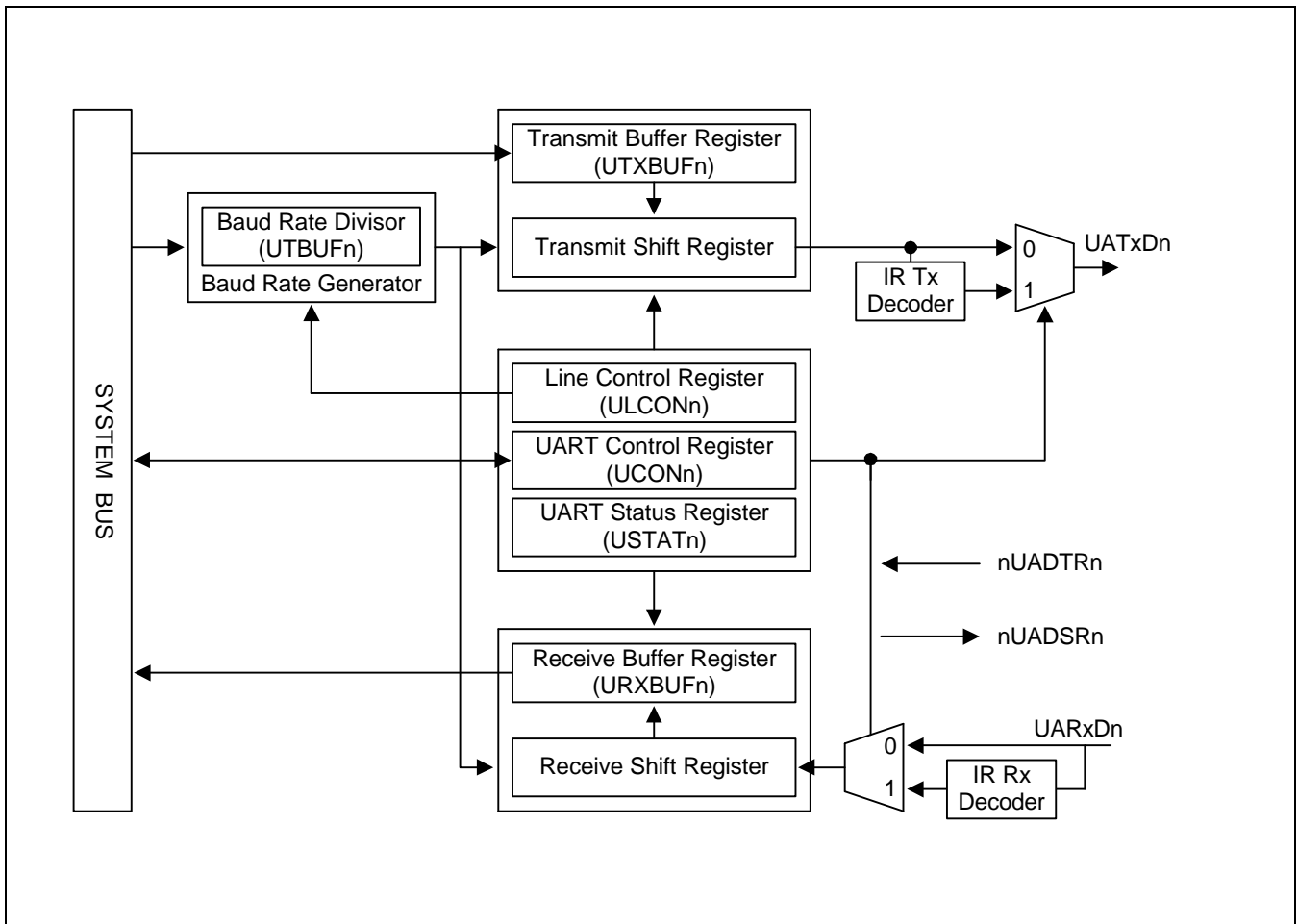

Figure 10-1. Serial I/O Block Diagram

## UART SPECIAL REGISTERS

Table 10-1. UART Special Registers Overview

Register	Offset Address	R/W	Description	Reset Value
ULCON0	0xD000	R/W	UART0 line control register	0x00
ULCON1	0xE000	R/W	UART1 line control register	0x00
UCON0	0xD004	R/W	UART0 control register	0x00
UCON1	0xE004	R/W	UART1 control register	0x00
USTAT0	0xD008	R	UART0 status register	0xC0
USTAT1	0xE008	R	UART1 status register	0xC0
UTXBUF0	0xD00C	W	UART0 transmit buffer register	0xFF
UTXBUF1	0xE00C	W	UART1 transmit buffer register	0xFF
URXBUF0	0xD010	R	UART0 receive buffer register	0xFF
URXBUF1	0xE010	R	UART1 receive buffer register	0xFF
UBRDIV0	0xD014	R/W	UART0 baud rate divisor register	0x00
UBRDIV1	0xE014	R/W	UART1 baud rate divisor register	0x00
BRDCNT0	0xD018	W	UART0 baud rate count register	0x00
BRDCNT1	0xE018	W	UART1 baud rate count register	0x00
BRDCLK0	0xD01C	W	UART0 baud rate clock monitor	0x0
BRDCLK1	0xE01C	W	UART1 baud rate clock monitor	0x0

## UART LINE CONTROL REGISTERS

Table 10-2. ULCON0 and ULCON1 Registers

Registers	Offset Address	R/W	Description	Reset Value
ULCON0	0xD000	R/W	UART0 line control register	0x00
ULCON1	0xE000	R/W	UART1 line control register	0x00

Table 10-3. UART Line Control Register Description

Bit Number	Bit Name	Reset Value
[1:0]	Word length (WL)	This two-bit word length value indicates the number of data bits to be transmitted or received per frame: '00' = 5 bits, '01' = 6 bits, '10' = 7 bits, and '11' = 8 bits.
[2]	Number of Stop bits	This bit specifies how many Stop bits are used to signal end-of-frame (EOF): "0" = one Stop bit per frame and "1" = two Stop bits per frame.
[5:3]	Parity mode (PMD)	The 3-bit parity mode value specifies how parity generation and checking are to be performed during UART transmit and receive operations: '0xx' = no parity, '100' = odd parity, '101' = even parity, '110' = parity is forced/checked as a "1", and '111' = parity forced/checked as a "0".
[6]	Serial Clock Selection	This selection bit specifies the clock source. 0 = Internal (MCLK) 1 = External (UCLK)
[7]	Infra-red mode	The S3C4510B UART block supports infra-red (IR) transmit and receive operations. In IR mode, the transmit period is pulsed at a rate of 3/16 that of the normal serial transmit rate (when the transmit data value in the UTXBUF register is zero). To enable IR mode operation, you set ULCON[7] to "1". Otherwise, the UART operates in normal mode. In IR receive mode, the receiver must detect the 3/16 pulsed period to recognize a zero value in the receiver buffer register, URXBUF, as the IR receive data. When bit [7] is "0", normal UART mode is selected. When it is "1", infra-red Tx/Rx mode is selected.

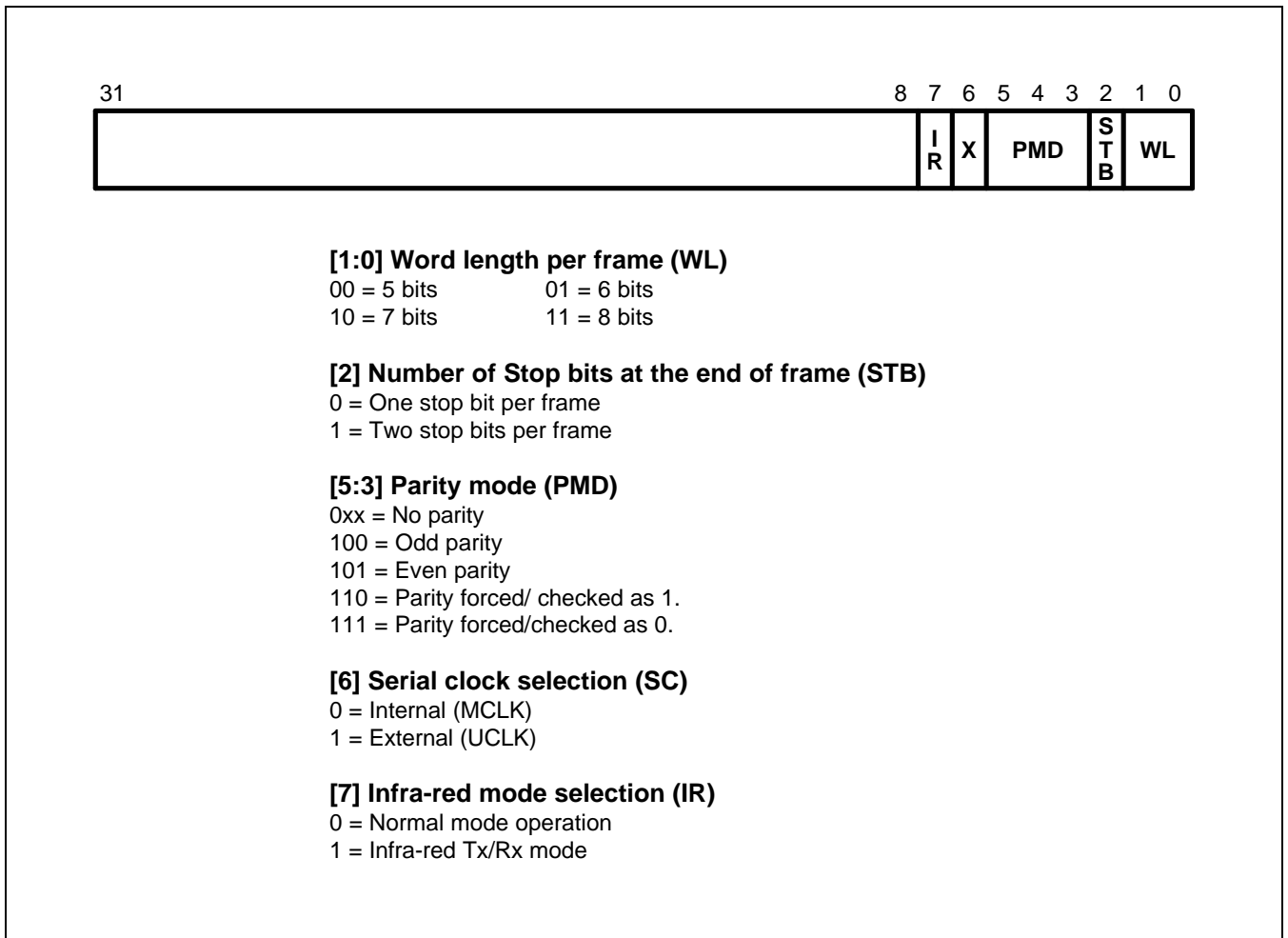

Figure 10-2. UART Line Control Registers

## UART CONTROL REGISTERS

Table 10-4. UCON0 and UCON1 Registers

Registers	Offset Address	R/W	Description	Reset Value
UCON0	0xD004	R/W	UART0 control register	0x00
UCON1	0xE004	R/W	UART1 control register	0x00

Table 10-5. UART Control Register Description

Bit Number	Bit Name	Reset Value
[1:0]	Receive mode (RxM)	This two-bit value determines which function is currently able to read data from the UART receive buffer register, RBR: '00' = disable Rx mode, '01' = interrupt request, '10' = GDMA channel 0 request, and '11' = GDMA channel 1 request.
[2]	Rx status interrupt enable	This bit lets the UART generate an interrupt if an exception (a break, frame error, parity error, or overrun error) occurs during a receive operation.  If this bit is set to "1", the UART generates a receive status interrupt. If this bit is "0", the receive status interrupt is not generated.
[4:3]	Transmit mode (TxM)	This two-bit value determines which function is currently able to write Tx data to the UART transmit buffer register, UTXBUF. '00' = disable Tx mode, '01' = interrupt request, '10' = GDMA channel 0 request, and '11' = GDMA channel 1 request.
[5]	Data set ready (DSR)	Setting UCON[5] causes the S3C4510B to assert its data set ready (DSR) signal output, nUADSR. Clearing this bit to "0" causes the DSR output to be de-asserted.
[6]	Send break	Setting UCON0/1[6] to "1" causes the UART to send a break. If it is "0", a break is not sent.  A break is defined as a continuous Low level signal on the transmit data output with a duration of more than one frame transmission time.  By setting this bit when the transmitter is empty (transmitter empty bit, USTAT[7] = "1"), you can use the transmitter to time the frame. When USTAT[7] is "1", write the transmit buffer register, UTXBUF, with the data to be transmitted. Then, poll the USTAT[7] value. When USTAT[7] returns to "1", clear (reset) the send break bit, UCON0/1[6].
[7]	Look-back mode	Setting this bit causes the UART to enter Loop-back mode. In Loop-back mode, the transmit data output is sent High level and the transmit buffer register, UTXBUF, is internally connected to the receive buffer register, URXBUF.  <b>NOTE:</b> This mode is provided for test purposes only. For normal operation, this bit should always be "0".





## UART STATUS REGISTER

Table 10-6. UCON0 and UCON1 Registers

Registers	Offset Address	R/W	Description	Reset Value
USTAT0	0xD008	R	UART0 status register	0xC0
USTAT1	0xE008	R	UART1 status register	0xC0

Table 10-7. UART Status Register Description

Bit Number	Bit Name	Reset Value
[0]	Overrun error	<p>USTAT[0] is automatically set to "1" whenever an overrun error occurs during a serial data receive operation. The overrun error indicates that the new received data has overwritten old received data before the old data could be read.</p> <p>If the receive status interrupt enable bit, UCON[2] is "1", a receive status interrupt is generated if an overrun error occurs.</p> <p>This bit is automatically cleared to "0" whenever the UART status register (USTAT) is read.</p>
[1]	Parity error	<p>USTAT[1] is automatically set to "1" whenever a parity error occurs during a serial data receive operation. If the receive status interrupt enable bit, UCON[2], is "1", a receive status interrupt is generated if a parity error occurs.</p> <p>This bit is automatically cleared to "0" whenever the UART status register (USTAT) is read.</p>
[2]	Frame error	<p>USTAT[2] is automatically set to "1" whenever a frame error occurs during a serial data receive operation. A frame error occurs when a zero is detected instead of the Stop bit(s).</p> <p>If the receive status interrupt enable bit, UCON[2] is "1", a receive status interrupt is generated if a frame error occurs.</p> <p>The frame error bit is automatically cleared to "0" whenever the UART status register (USTAT) is read.</p>
[3]	Break interrupt	<p>USTAT[3] is automatically set to "1" to indicate that a break signal has been received.</p> <p>If the receive status interrupt enable bit, UCON[2], is "1", a receive status interrupt is generated if a break occurs.</p> <p>The break interrupt bit is automatically cleared to "0" when you read the UART status register.</p>
[4]	Data terminal ready (DTR)	<p>The USTAT[4] bit indicates the current signal level at the data terminal ready (DTR) pins (nUADTR). When this bit is "1", the level at the DTR pin (nUADTR) is Low. When it is "0", the DTR pin is High level.</p>

Table 10-7. UART Status Register Description (Continued)

Bit Number	Bit Name	Reset Value
[5]	Receive data ready	<p>USTAT[5] is automatically set to "1" whenever the receive data buffer register (URXBUF) contains valid data received over the serial port. The receive data can then be read from the URXBUF. When this bit is "0", the URXBUF does not contain valid data.</p> <p>Depending on the current setting of the UART receive mode bits, UCON[1:0], an interrupt or a DMA request is generated when USTAT[5] is "1".</p>
[6]	Tx Buffer register empty	<p>USTAT[6] is automatically set to "1" when the transmit buffer register (UTXBUF) does not contain valid data. In this case, the UTXBUF can be written with the data to be transmitted.</p> <p>When this bit is "0", the UTXBUF contains valid Tx data that has not yet been copied to the transmit shift register. In this case, the UTXBUF cannot be written with new Tx data.</p> <p>Depending on the current setting of the SIO transmit mode bits, UCON[4:3], an interrupt or a DMA request will be generated whenever USTAT[6] is "1".</p>
[7]	Transmit complete (TC)	<p>USTAT[7] is automatically set to "1" when the transmit buffer register has no valid data to transmit and when the Tx shift register is empty. When the transmitter empty bit is "1", it indicates to software that it can now disable the transmitter function block.</p>

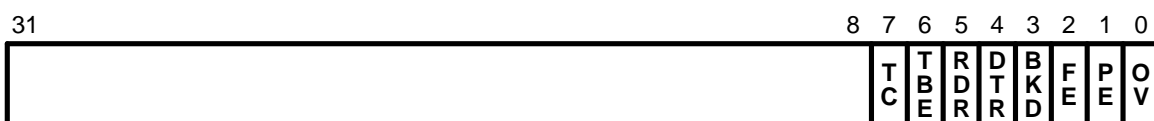
**[0] Overrun error (OV)**

0 = No overrun error during receive

1 = Overrun error (generate receive status interrupt if UCON[2] is 1)

**[1] Parity error (PE)**

0 = No parity error during receive

1 = Parity error (generate receive status interrupt if UCON[2] is 1)

**[2] Frame error (FE)**

0 = No frame error during receive

1 = Frame error (generate receive status interrupt if UCON[2] is 1)

**[3] Break detect (BKD)**

0 = No break received

1 = Break received (generate receive status interrupt if UCON[2] is 1)

**[4] Data terminal ready (DTR)**

0 = DTR pin (nUADTR) is High

1 = DTR pin (nUADTR) is Low

**[5] Receive data ready (RDR)**

0 = No valid data in the receive buffer register

1 = Valid data present in the receive buffer register  
(issue interrupt or DMA request if UCON[1:0] is set)**[6] Transmit buffer register empty (TBE)**

0 = Valid data in transmit holding register

1 = No data in transmit holding register  
(as the setting of UCON[4:3], interrupt or GDMA request is generated)**[7] Transmit complete (TC)**

0 = Transmit in progress

1 = Transmit complete; no data for Tx

Figure 10-4. UART Status Registers

## UART TRANSMIT BUFFER REGISTER

The UART transmit buffer registers, UTXBUF0 and UTXBUF1, contain an 8-bit data value to be transmitted over the UART channel.

**Table 10-8. UXTBUF0 and UXTBUF1 Registers**

Registers	Offset Address	R/W	Description	Reset Value
UTXBUF0	0xD00C	W	UART0 transmit buffer register	0xFF
UTXBUF1	0xE00C	W	UART1 transmit buffer register	0xFF

**Table 10-9. UART Status Register Description**

Bit Number	Bit Name	Reset Value
[7:0]	Transmit data	This field contains the data to be transmitted over the single channel UART. When this register is written, the transmit buffer register empty bit in the status register, USTAT[6], should be "1". This is to prevent overwriting of transmit data that may already be present in the UTXBUF. Whenever the UTXBUF is written with a new value, the transmit register empty bit, USTAT[6], is automatically cleared to "0".

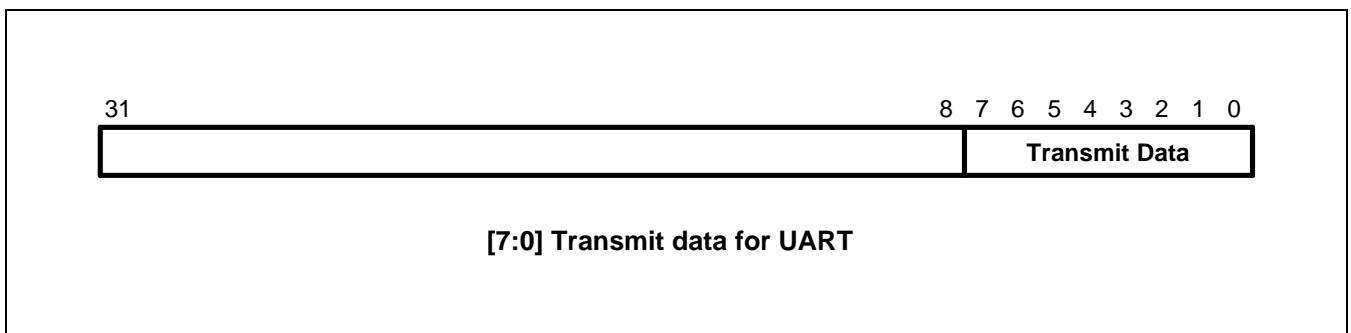

**Figure 10-5. UART Transmit Buffer Registers**

**UART RECEIVE BUFFER REGISTER**

The UART receive buffer registers, URXBUF0 and URXBUF1, contain an 8-bit data value for received serial data.

**Table 10-10. UXRBUF0 and UXRBUF1 Registers**

Registers	Offset Address	R/W	Description	Reset Value
URXBUF0	0xD010	R	UART0 receive buffer register	0xFF
URXBUF1	0xE010	R	UART1 receive buffer register	0xFF

**Table 10-11. UART Transmit Register Description**

Bit Number	Bit Name	Reset Value
[7:0]	Receive data	This field contains the data received over the single channel UART. When the UART finishes receiving a data frame, the receive data ready bit in the UART status register, USTAT[5], should be "1". This prevents reading invalid receive data that may already be present in the URXBUF. Whenever the URXBUF is read, the receive data ready bit(USTAT[5]) is automatically cleared to "0".

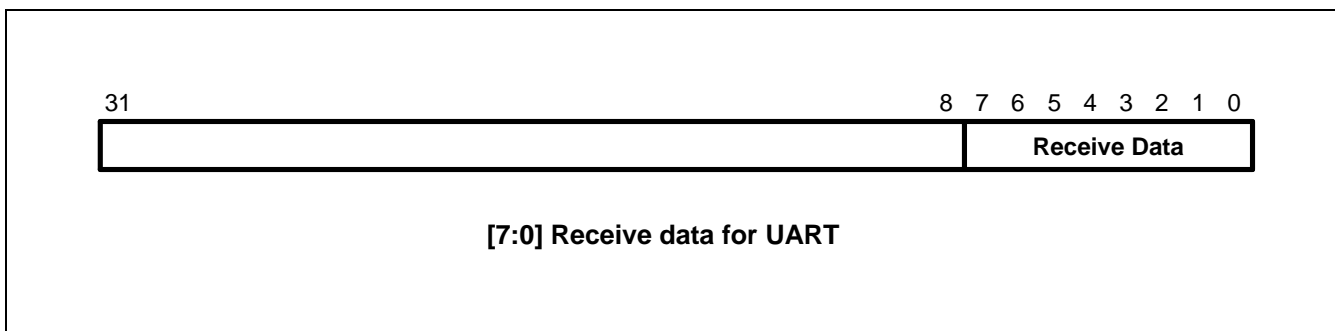

**Figure 10-6. UART Receive Buffer Registers**

### UART BAUD RATE DIVISOR REGISTER

The values stored in the baud rate divisor registers, UBRDIV0 and UBRDIV1, let you determine the serial Tx/Rx clock rate (baud rate) as follows:

$$\text{BRGOUT} = (\text{MCLK2 or UCLK}) / (\text{CNT0} + 1) / (16^{\text{CNT1}}) / 16$$

**Table 10-12. UBRDIV0 and UBRDIV0 Registers**

Registers	Offset Address	R/W	Description	Reset Value
UBRDIV0	0xD014	R/W	UART0 baud rate divisor register	0x00
UBRDIV1	0xE014	R/W	UART1 baud rate divisor register	0x00

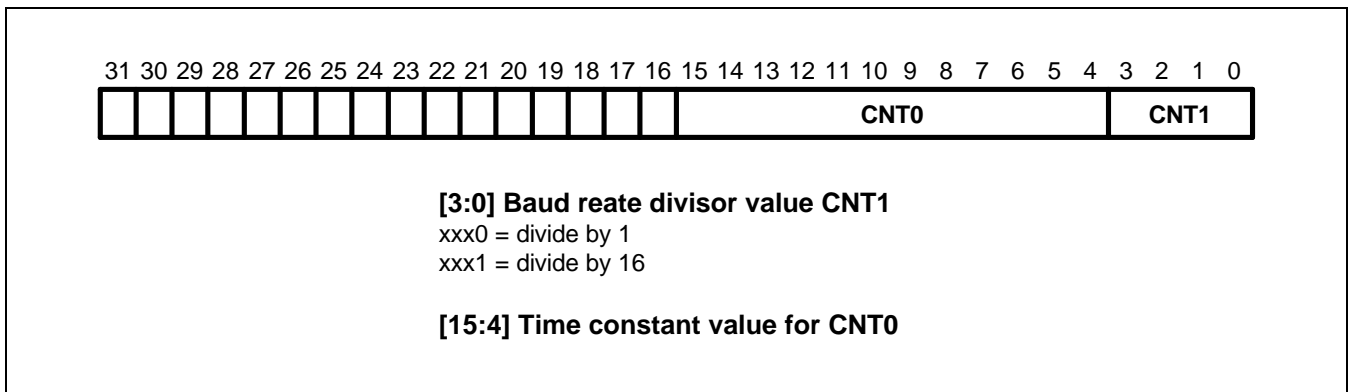

**Figure 10-7. UART Baud Rate Divisor Registers**

**UART BAUD RATE COUNT AND CLOCK REGISTERS**

For test purpose only, the internal baud rate up counters, BRDCNT0 and BRDCNT1, can be directly accessed using register addressing. In addition, the baud rate clock can be monitored through the UART data set ready ports, nUADSR.

If the BRDCLKn monitor value is "1", the baud rate clock can be monitored at the nUADSR pin. If it is "0" (its default value), or if you write a "0" to the BRDCLKn address, the UARD DSR signal output to the nUADSR port depends on the current setting of UART control register bit 5.

**Table 10-13. BRDCNTn and BRDCLKn Registers**

Register	Offset Address	R/W	Description	Reset Value
BRDCNT0	0xD018	W	UART0 baud rate count register	0x0
BRDCNT1	0xE018	W	UART1 baud rate count register	0x0
BRDCLK0	0xD01C	W	UART0 baud rate clock monitor	0x0
BRDCLK1	0xE01C	W	UART1 baud rate clock monitor	0x0

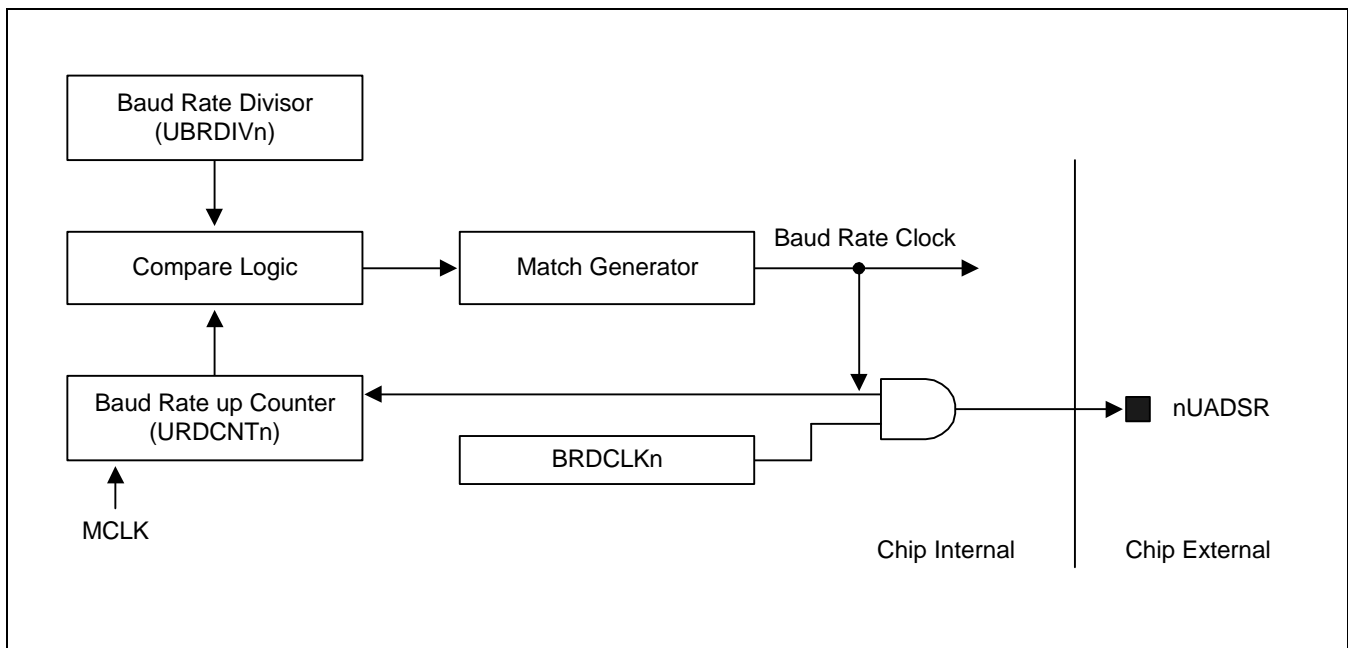

**Figure 10-8. UART Baud Rate Clock Test Scheme**



**UART BAUD RATE EXAMPLES**

UART BRG input clock, MCLK2 is the system clock frequency divided by 2.

If the system clock frequency is 50 MHz and MCLK2 is selected, the maximum BRGOUT output clock rate is MCLK2/16 (= 1.5625 MHz).

UCLK is the external clock input pin for UART0, UART1. UART BRG input clock, MCLK2, UCLK can be selected by UCCON[6] register.

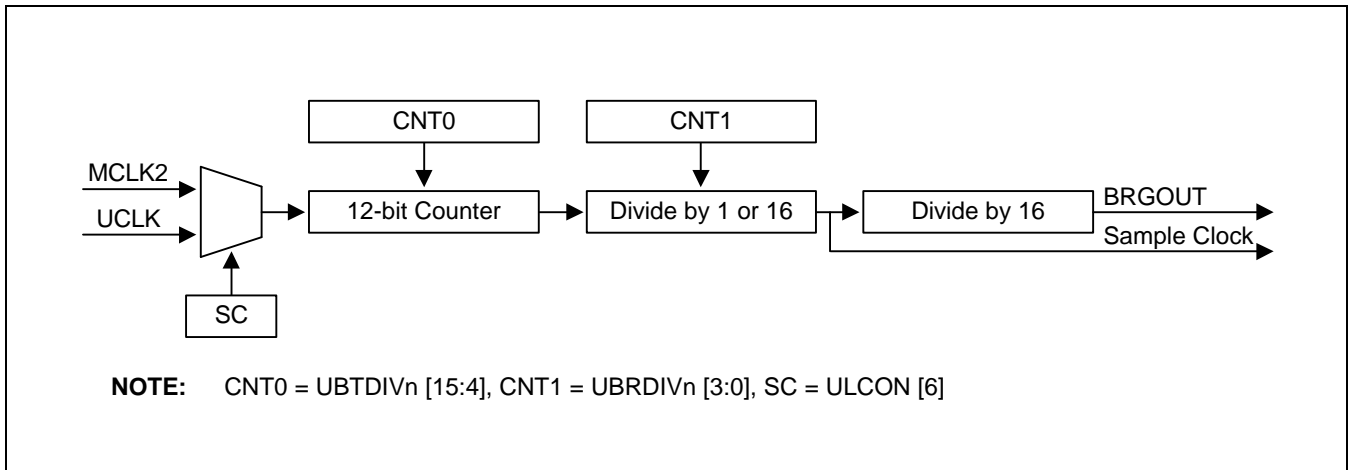

**Figure 10-9. UART Baud Rate Generator (BRG)**

**Table 10-14. Typical Baud Rates Examples of UART**

Baud Rates (BRGOUT)	MCLK2 = 25 MHz				UCLK = 33 MHz			
	CNT0	CNT1	Freq.	Dev.(%)	CNT0	CNT1	Freq.	Dev.(%)
1200	1301	0	1200.1	0.0	1735	1	1200.08	0.0064
2400	650	0	2400.2	0.0	867	1	2400.15	0.0064
4800	324	0	4807.7	0.2	433	0	4800.31	0.0064
9600	162	0	9585.9	- 0.1	216	0	9600.61	0.0064
19200	80	0	19290.1	0.5	108	0	19113.15	0.45
38400	40	0	38109.8	- 0.8	53	0	38580.15	0.47
57600	26	0	57870.4	0.5	35	0	57870.37	0.47
115200	13	0	111607.1	- 3.1	17	0	115740.74	0.47
230400	6	0	223214.28	3.12	8	0	231481.48	0.47
460860	2	0	520833.34	13.01	4	0	416666.66	9.59

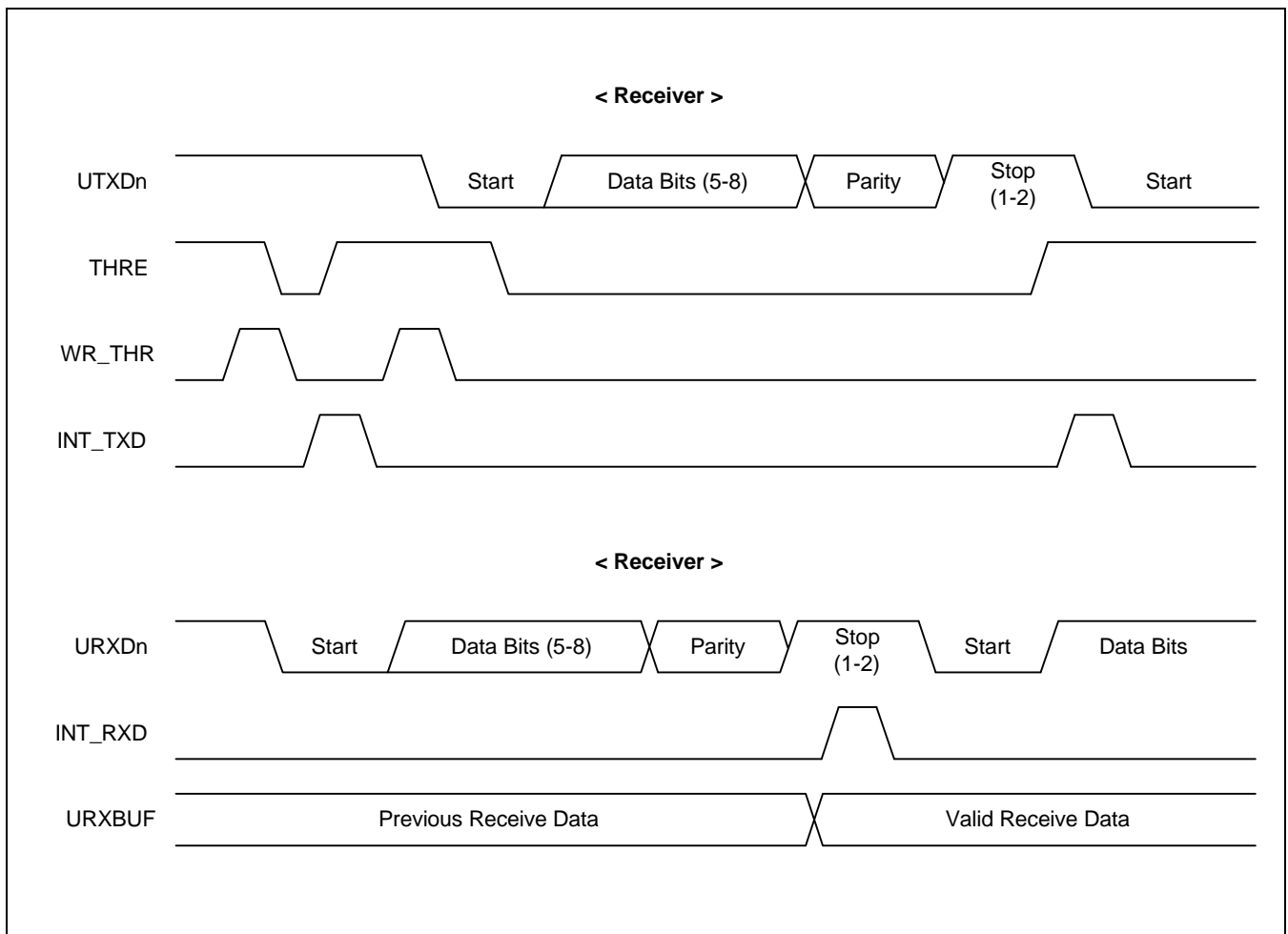

Figure 10-10. Interrupt-Based Serial I/O Timing Diagram (Tx and Rx Only)

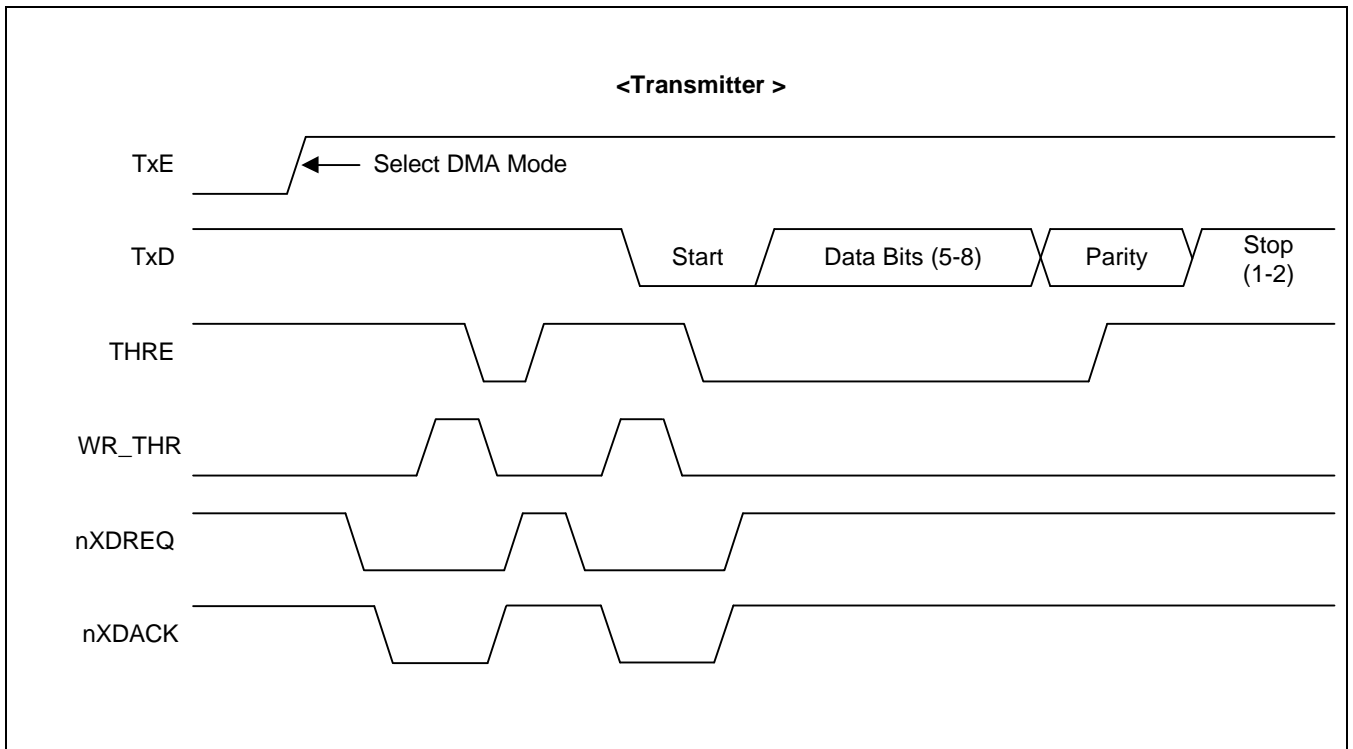

Figure 10-11. DMA-Based Serial I/O Timing Diagram (Tx Only)

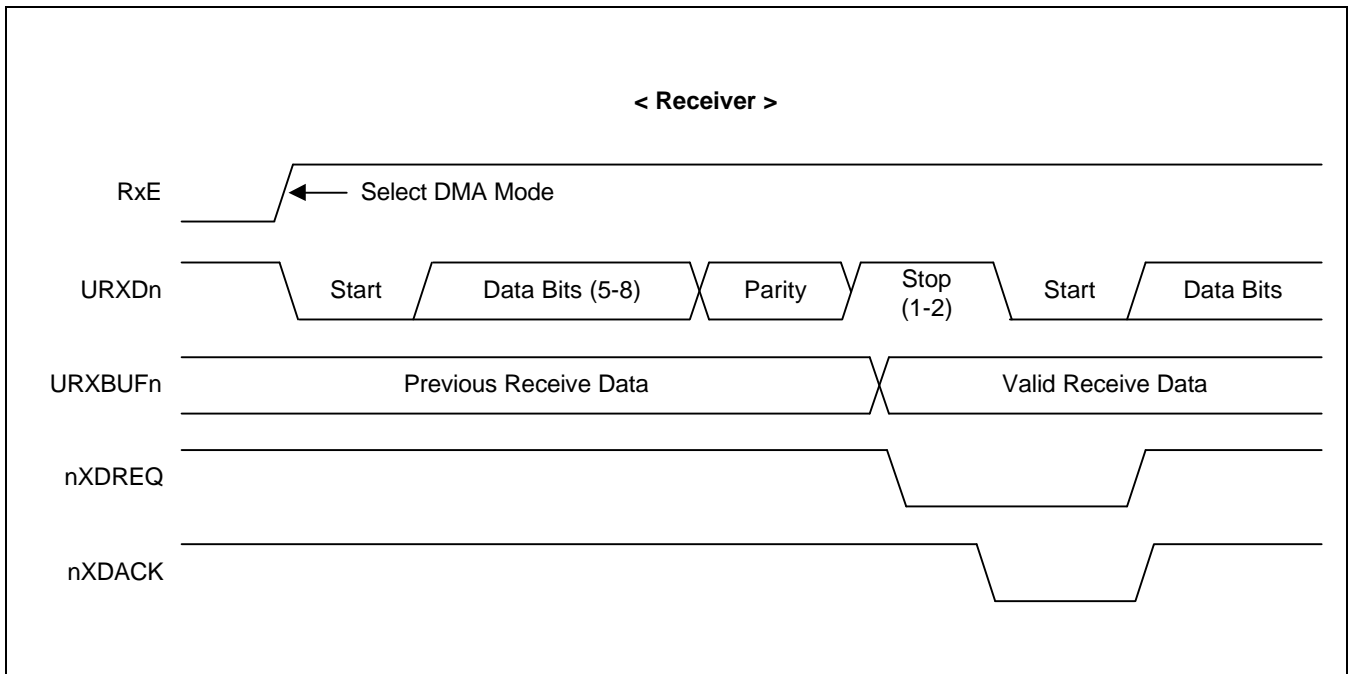

Figure 10-12. DMA-Based Serial I/O Timing Diagram (Rx Only)

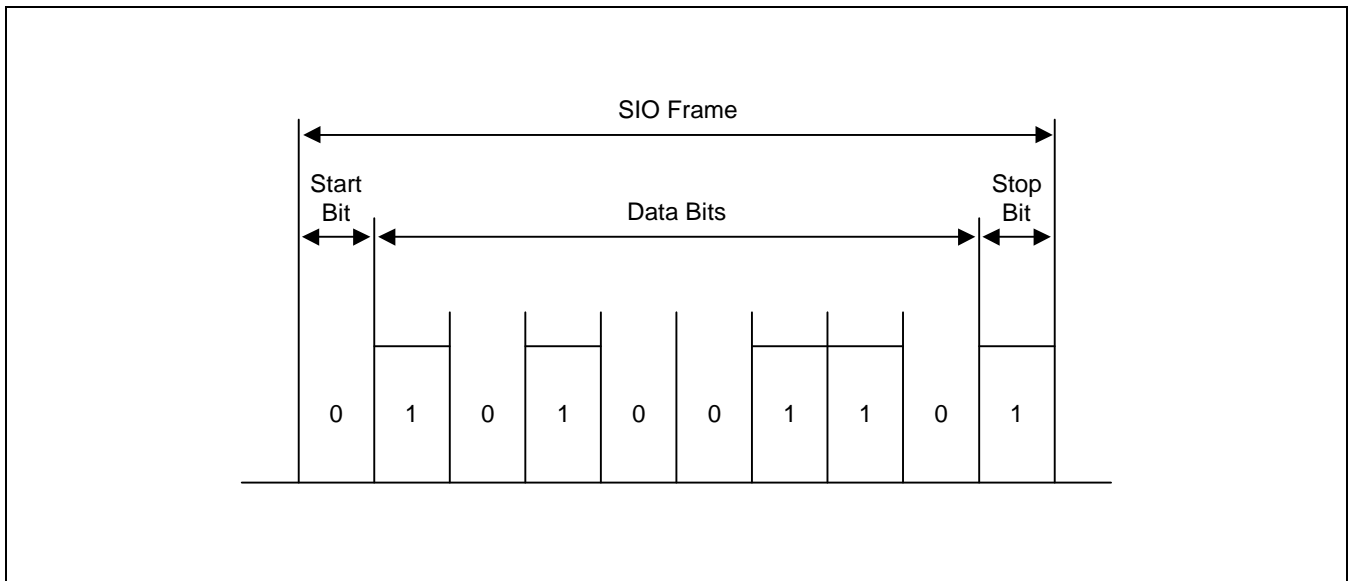

Figure 10-13. Serial I/O Frame Timing Diagram (Normal UART)

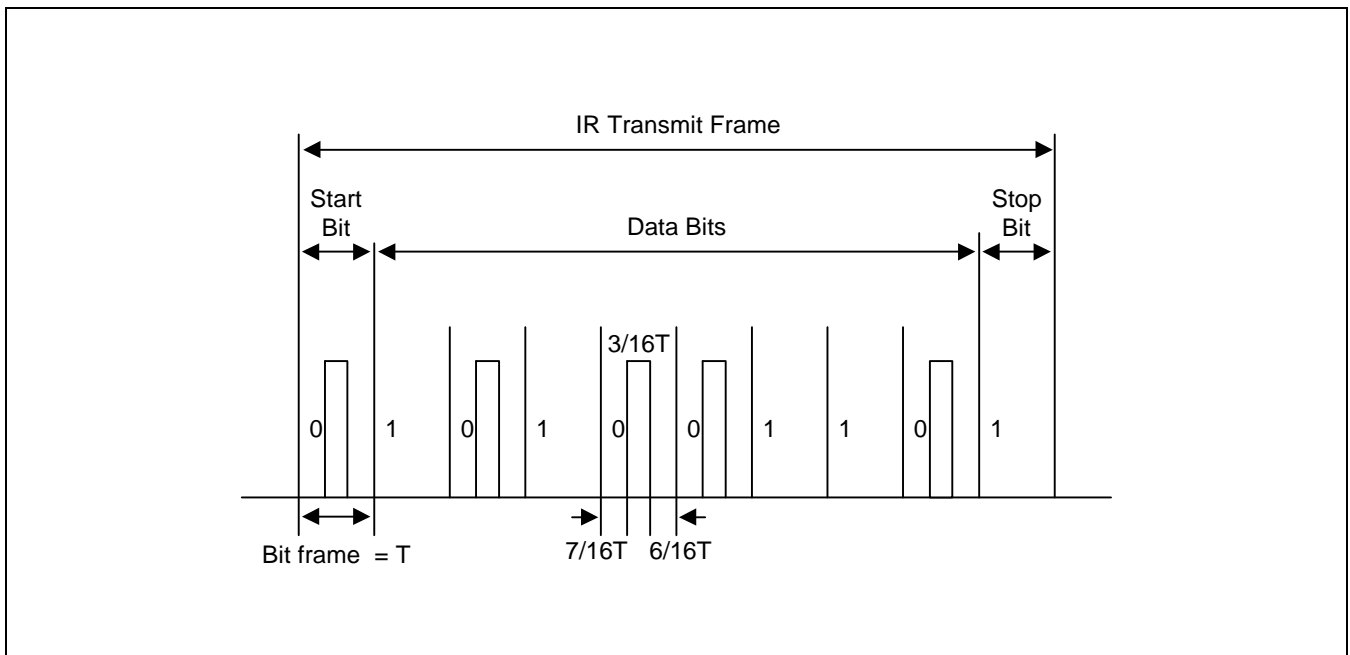

Figure 10-14. Infra-Red Transmit Mode Frame Timing Diagram

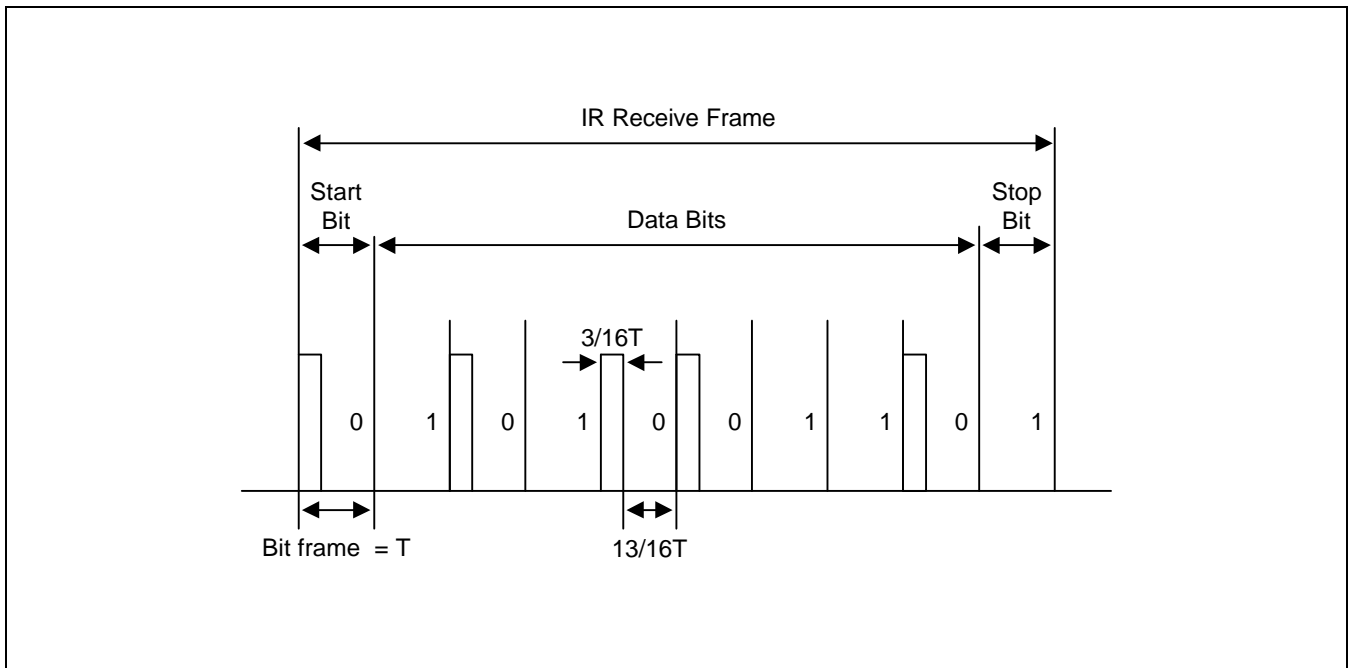

Figure 10-15. Infra-Red Receive Mode Frame Timing Diagram

## NOTES

# 11

## 32-BIT TIMERS

### OVERVIEW

The S3C4510B has two 32-bit timers. These timers can operate in interval mode or in toggle mode. The output signals are TOUT0 and TOUT1, respectively.

You enable or disable the timers by setting control bits in the timer control register, TCON. An interrupt request is generated whenever a timer count-out (down count) occurs.

### INTERVAL MODE OPERATION

In interval mode, a timer generates a one-shot pulse of a preset timer clock duration whenever a time-out occurs. This pulse generates a time-out interrupt that is directly output at the timer's configured output pin (TOUTn). In this case, the timer frequency monitored at the TOUTn pin is calculated as:

$$f_{\text{TOUT}} = f_{\text{MCLK}} / \text{Timer data value}$$

### TOGGLE MODE OPERATION

In toggle mode, the timer pulse continues to toggle whenever a time-out occurs. An interrupt request is generated whenever the level of the timer output signal is inverted (that is, when the level toggles). The toggle pulse is output directly at the configured output pin.

Using toggle mode, you can achieve a flexible timer clock range with 50% duty. In toggle mode, the timer frequency monitored at the TOUTn pin is calculated as follows:

$$f_{\text{TOUT}} = f_{\text{MCLK}} / (2 * \text{Timer data value})$$

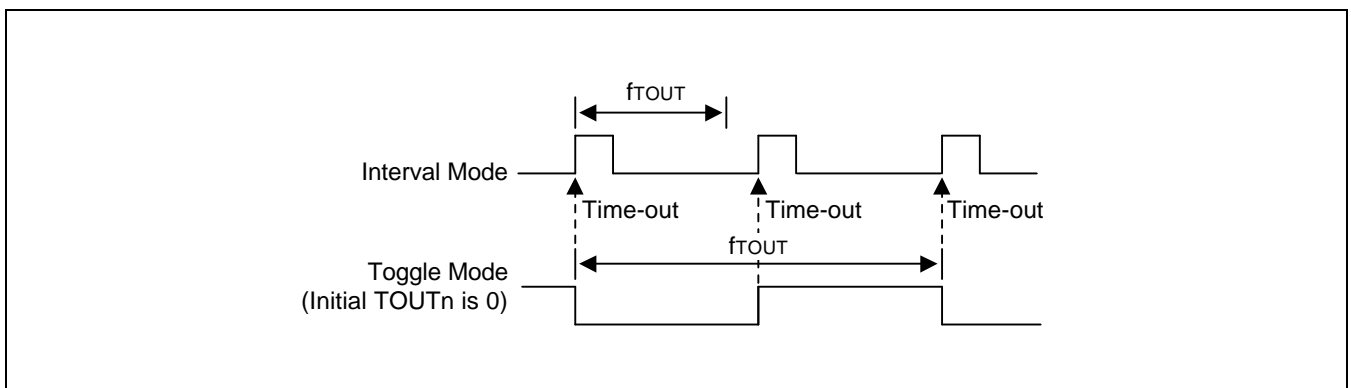

Figure 11-1. Timer Output Signal Timing

### TIMER OPERATION GUIDELINES

The block diagram in Figure 11-2 shows how the 32-bit timers are configured in the S3C4510B. The following guidelines apply to timer functions.

- When a timer is enabled, it loads a data value to its count register and begins decrement the count register value.
- When the timer interval expires, the associated interrupt is generated. The base value is then reloaded and the timer continues decrement its count register value.
- If a timer is disabled, you can write a new base value into its registers.
- If the timer is halted while it is running, the base value is not automatically re-loaded.

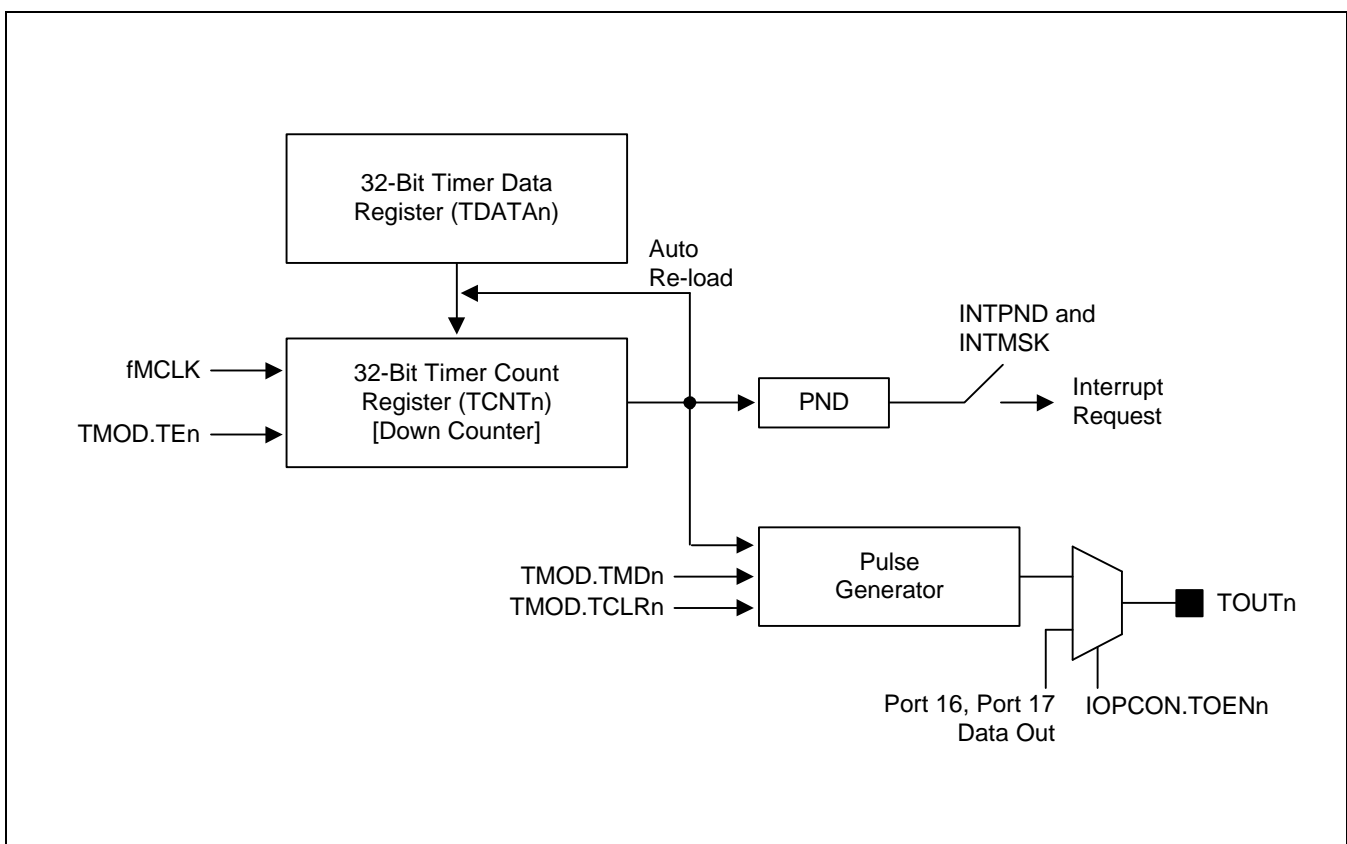

Figure 11-2. 32-Bit Timer Block Diagram



## TIMER MODE REGISTER

The timer mode register, TMOD, is used to control the operation of the two 32-bit timers. TMOD register settings are described in Figure 11-3.

Table 11-1. TMOD Register

Register	Offset Address	R/W	Description	Reset Value
TMOD	0x6000	R/W	Timer mode register	32'h00000000

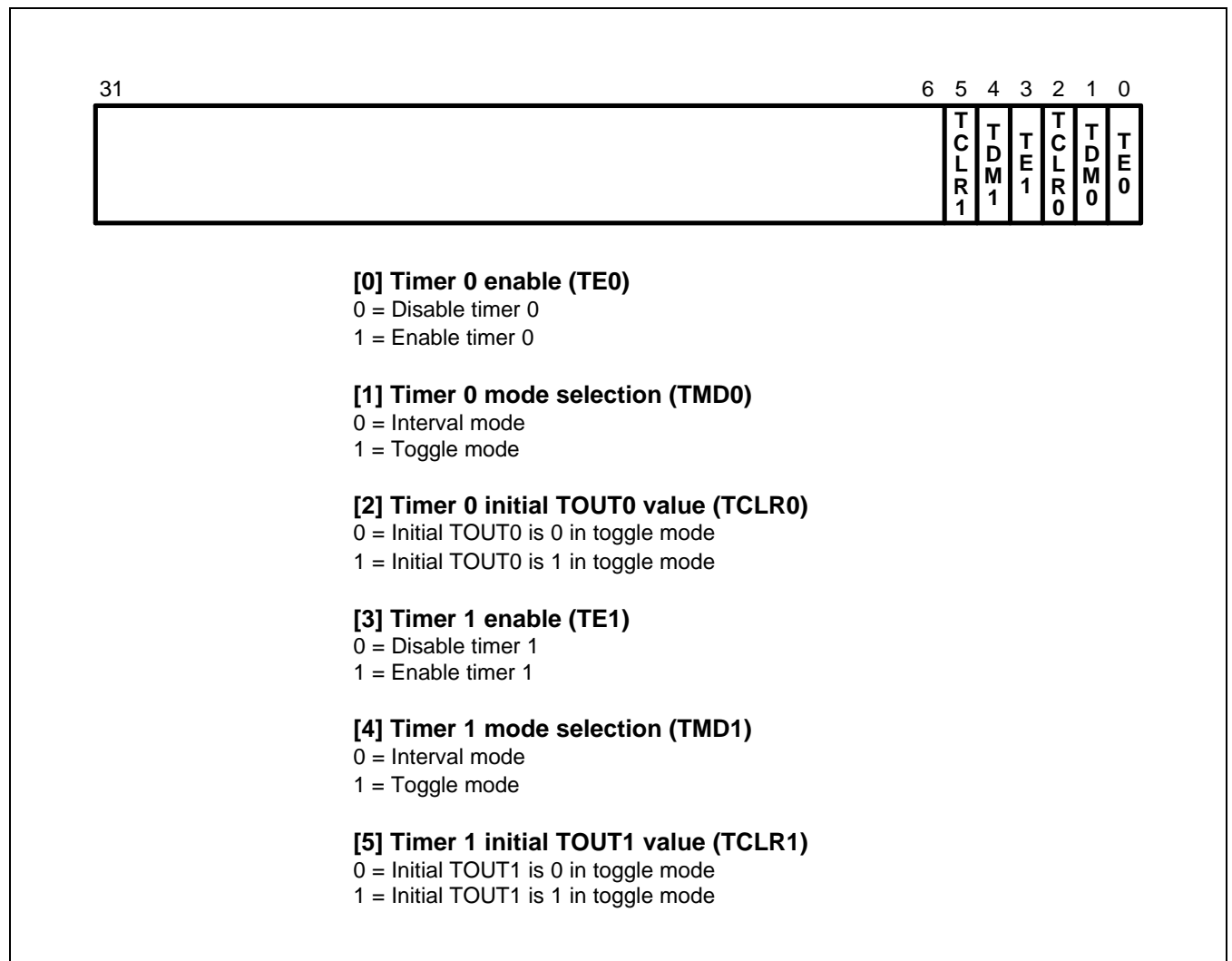

Figure 11-3. Timer Mode Register (TMOD)

## TIMER DATA REGISTERS

The timer data registers, TDATA0 and TDATA1, contain a value that specifies the time-out duration for each timer. The formula for calculating the time-out duration is: (Timer data + 1) cycles.

**Table 11-2. TDATA0 and TDATA1 Registers**

Register	Offset Address	R/W	Description	Reset Value
TDATA0	0x6004	R/W	Timer 0 data register	0x00000000
TDATA1	0x6008	R/W	Timer 1 data register	0x00000000

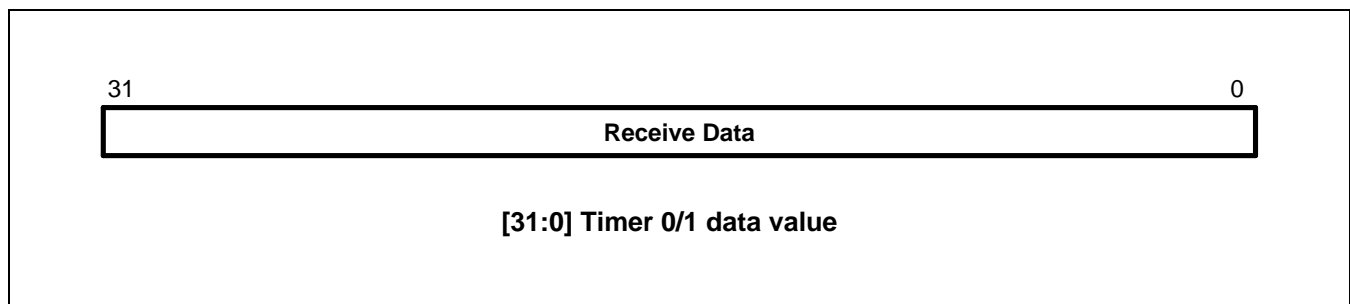

**Figure 11-4. Timer Data Registers (TDATA0, TDATA1)**

## TIMER COUNT REGISTERS

The timer count registers, TCNT0 and TCNT1, contain the current timer 0 and 1 count value, respectively, during normal operation.

**Table 11-3. TCNT0 and TCNT1 Registers**

Register	Offset Address	R/W	Description	Reset Value
TCNT0	0x600C	R/W	Timer 0 counter register	0xFFFFFFFF
TNCT1	0x6010	R/W	Timer 1 counter register	0xFFFFFFFF

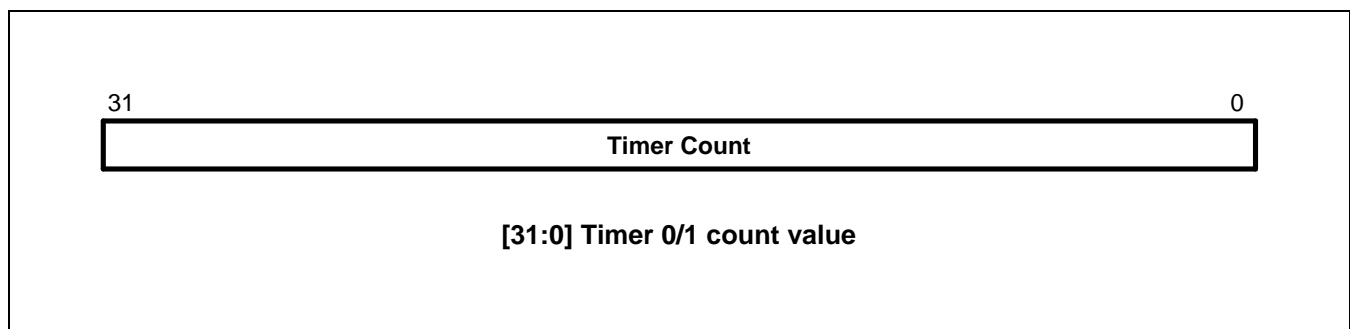

**Figure 11-5. Timer Counter Registers (TCNT0, TCNT1)**

# 12 I/O PORTS

## OVERVIEW

The S3C4510B has 18 programmable I/O ports. You can configure each I/O port to input mode, output mode, or special function mode. To do this, you write the appropriate settings to the IOPMOD and IOPCON registers. User can set filtering for the input ports using IOPCON register.

The modes of the ports from port0 to port7 are determined only by the IOPMOD register. But port[11:8] can be used as xINTREQ[3:0], port[13:12] as nXDREQ[1:0], port[15:14] as nXDACK[1:0], port[16] as TOUT0, or port[17] as TOUT1 depending on the settings in IOPCON register.

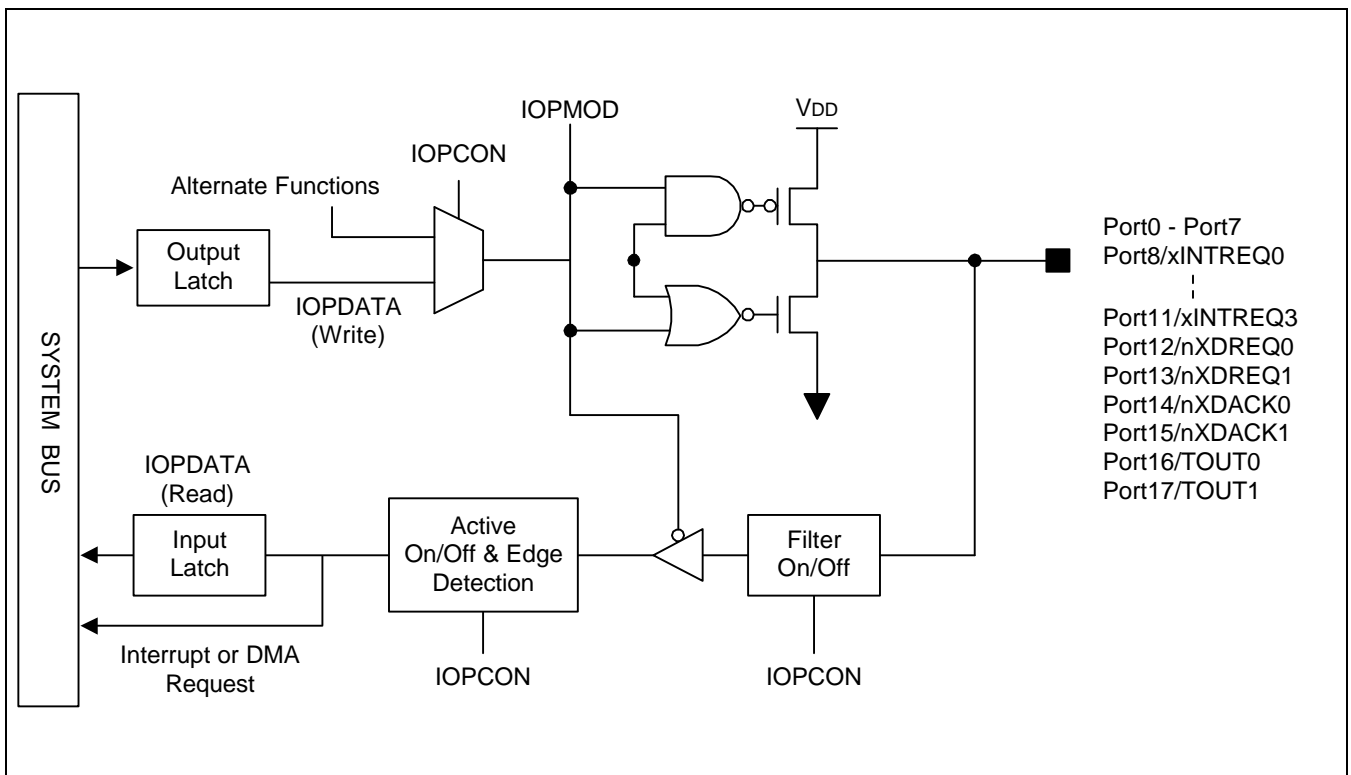

Figure 12-1. I/O Port Function Diagram

## I/O PORT SPECIAL REGISTERS

Three registers control the I/O port configuration: IOPMOD, IOPCON, and IOPDATA. These registers are described in detail below.

### I/O PORT MODE REGISTER (IOPMOD)

The I/O port mode register, IOPMOD, is used to configure the port pins, P17–P0.

#### NOTE

If the port is used for a special function such as an external interrupt request, an external DMA request, or acknowledge signal and timer outputs, its mode is determined by the IOPCON register, not by IOPMOD.

Table 12-1. IOPMOD Register

Register	Offset Address	R/W	Description	Reset Value
IOPMOD	0x5000	R/W	I/O port mode register	0x00000000

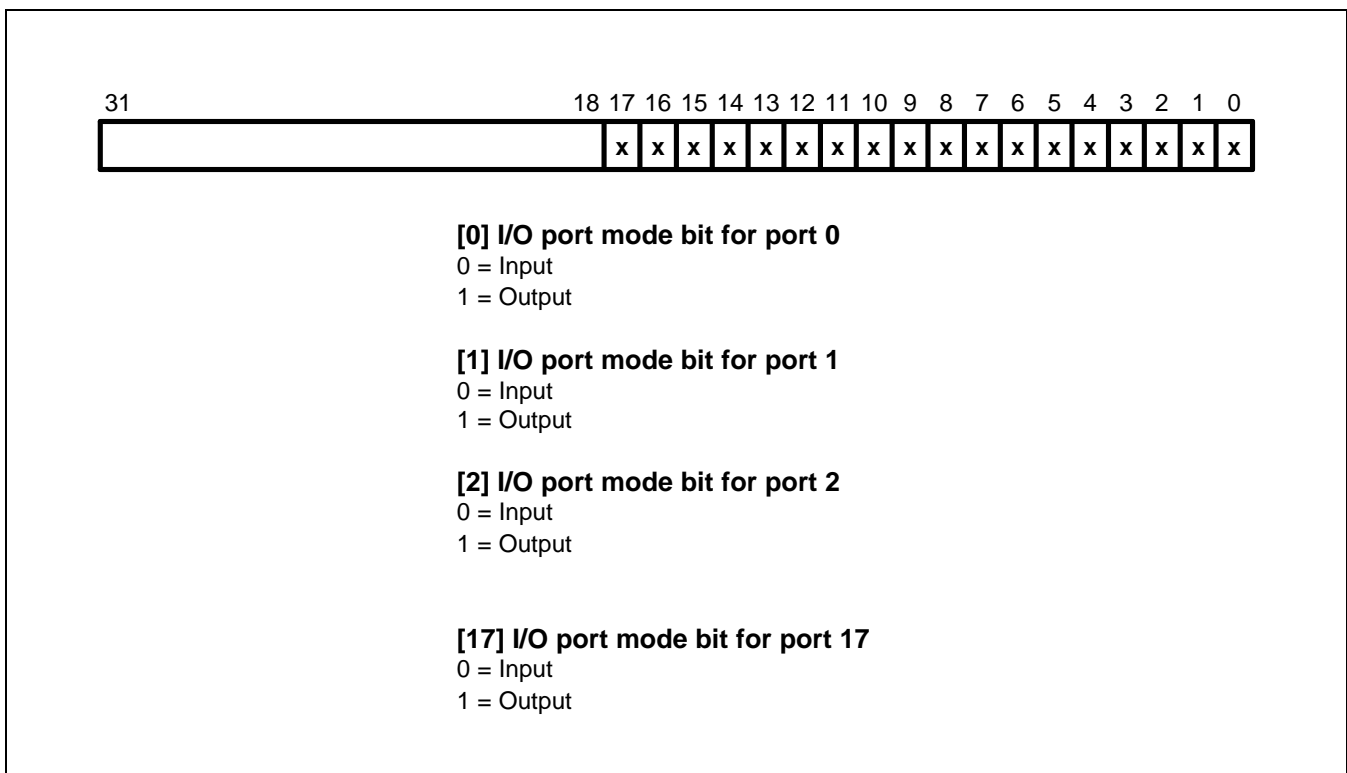

Figure 12-2. I/O Port Mode Register (IOPMOD)

**I/O PORT CONTROL REGISTER (IOPCON)**

The I/O port control register, IOPCON, is used to configure the port pins, P17–P8.

**NOTE**

If the port is used for a special function such as an external interrupt request, an external DMA request, or acknowledge signal and timer outputs, its mode is determined by the IOPCON register, not by IOPMOD.

For the special input ports, S3C4510A provides 3-tap filtering. If the input signal levels are same for the three system clock periods, that level is taken as input for dedicated signals such as external interrupt requests and external DMA requests.

**Table 12-2. IOPCON Register**

Register	Offset Address	R/W	Description	Reset Value
IOPCON	0x5004	R/W	I/O port control register	0x00000000

31	30	29	28	27	26	25	23	22	20	19	15	14	10	9	5	4	3	2	1	0
TOEN1	TOEN0	DAK1	DAK0	DRQ1	DRQ0					XIRQ3		XIRQ2		XIRQ1					XIRQ1	

**[4:0] Control external interrupt request 0 input for port 8 (xIRQ0)**

[4] Port 8 for xINTREQ0

- |                             |                            |
|-----------------------------|----------------------------|
| 0 = Disable                 | 1 = Enable                 |
| [3] 0 = Active Low          | 1 = Active High            |
| [2] 0 = Filtering off       | 1 = Filtering on           |
| [1:0] 00 = Level detection  | 01 = Rising edge detection |
| 10 = Falling edge detection | 11 = Both edge detection   |

**[9:5] Control external interrupt request 1 input for port 9 (xIRQ1)**

(See control external interrupt request 1.)

**[14:10] Control external interrupt request 2 input for port 10 (xIRQ2)**

(See control external interrupt request 2.)

**[19:15] Control external interrupt request 3 input for port 11 (xIRQ3)**

(See control external interrupt request 3.)

**[22:20] Control external DMA request 0 input for port 12 (DRQ0)**

[22] Port 12 for nXDREQ0

- |                        |                  |
|------------------------|------------------|
| 0 = Disable            | 1 = Enable       |
| [21] 0 = Filtering off | 1 = Filtering on |
| [20] 0 = Active Low    | 1 = Active High  |

**[25:23] Control external DMA request 1 input for port 13 (DRQ1)**

[25] Port 13 for nXDREQ1

- |                        |                  |
|------------------------|------------------|
| 0 = Disable            | 1 = Enable       |
| [24] 0 = Filtering off | 1 = Filtering on |
| [23] 0 = Active Low    | 1 = Active High  |

**[27:26] Control external DMA acknowledge 0 output for port 14 (DAK0)**

[27] Port 14 for nXDACK0

- |                     |                 |
|---------------------|-----------------|
| 0 = Disable         | 1 = Enable      |
| [26] 0 = Active Low | 1 = Active High |

**[29:28] Control external DMA acknowledge 1 output for port 15 (DAK1)**

[29] Port 15 for nXDACK1

- |                     |                 |
|---------------------|-----------------|
| 0 = Disable         | 1 = Enable      |
| [28] 0 = Active Low | 1 = Active High |

**[30] Control timeout 0 for port 16 (TOEN0)**

- |             |            |
|-------------|------------|
| 0 = Disable | 1 = Enable |
|-------------|------------|

**[31] Control timeout 1 for port 17 (TOEN1)**

- |             |            |
|-------------|------------|
| 0 = Disable | 1 = Enable |
|-------------|------------|

Figure 12-3. I/O Port Control Register (IOPCON)

**I/O PORT DATA REGISTER (IOPDATA)**

The I/O port data register, IOPDATA, contains one-bit read values for I/O ports that are configured to input mode and one-bit write values for ports that are configured to output mode. Bits[17:0] of the 18-bit I/O port register value correspond directly to the 18 port pins, P17–P0.

**Table 12-3. IOPDATA Register**

Register	Offset Address	R/W	Description	Reset Value
IOPDATA	0x5008	R/W	I/O port data register	Undefined

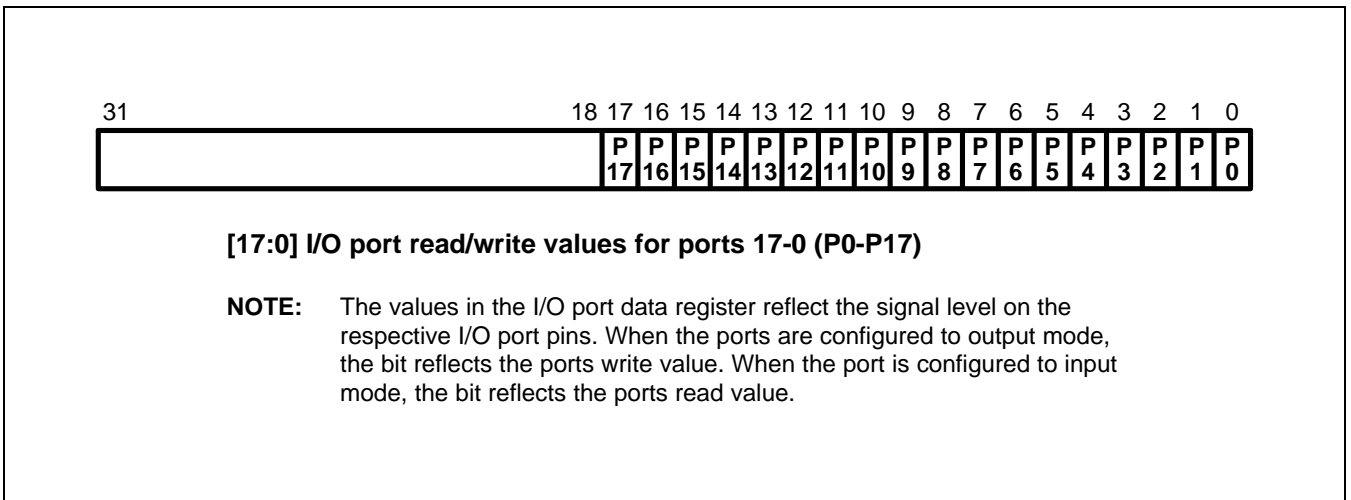

**Figure 12-4. I/O Port Data Register (IOPDATA)**

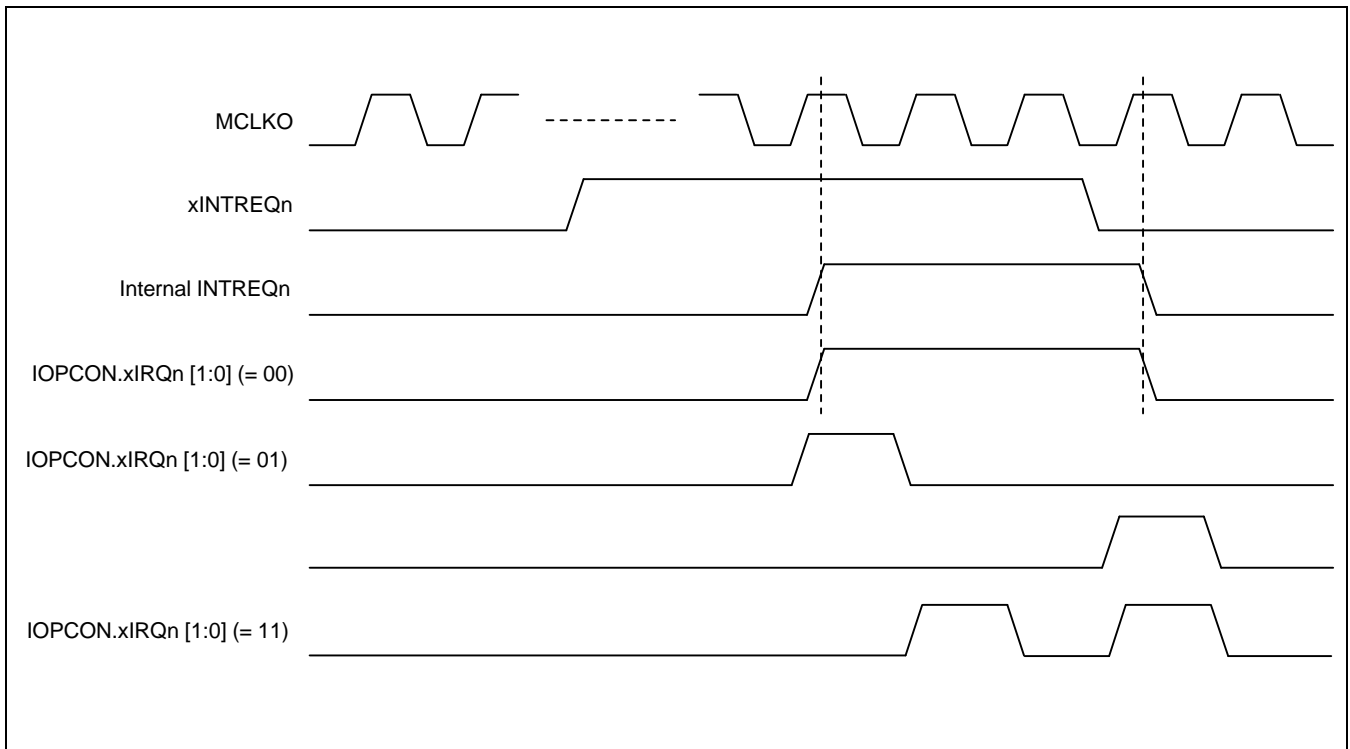

Figure 12-5. External Interrupt Request Timing (Active High)

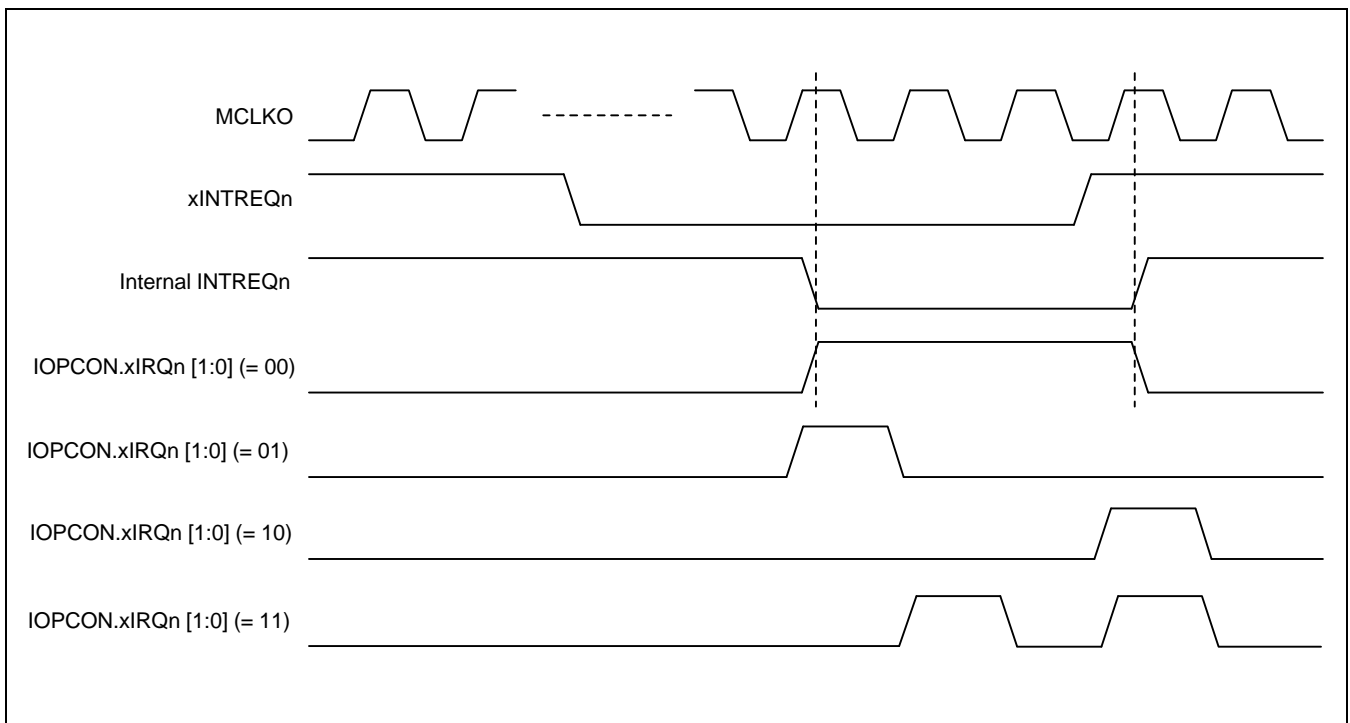

Figure 12-6. External Interrupt Request Timing (Active Low)



# 13

## INTERRUPT CONTROLLER

### OVERVIEW

The S3C4510B interrupt controller has a total of 21 interrupt sources. Interrupt requests can be generated by internal function blocks and at external pins.

The ARM7TDMI core recognizes two kinds of interrupts: a normal interrupt request (IRQ), and a fast interrupt request (FIQ). Therefore all S3C4510B interrupts can be categorized as either IRQ or FIQ. The S3C4510B interrupt controller has an interrupt pending bit for each interrupt source.

Four special registers are used to control interrupt generation and handling:

- Interrupt priority registers. The index number of each interrupt source is written to the pre-defined interrupt priority register field to obtain that priority. The interrupt priorities are pre-defined from 0 to 20.
- Interrupt mode register. Defines the interrupt mode, IRQ or FIQ, for each interrupt source.
- Interrupt pending register. Indicates that an interrupt request is pending. If the pending bit is set, the interrupt pending status is maintained until the CPU clears it by writing a "1" to the appropriate pending register. When the pending bit is set, the interrupt service routine starts whenever the interrupt mask register is "0". The service routine must clear the pending condition by writing a "1" to the appropriate pending bit. This avoids the possibility of continuous interrupt requests from the same interrupt pending bit.
- Interrupt mask register. Indicates that the current interrupt has been disabled if the corresponding mask bit is "1". If an interrupt mask bit is "0" the interrupt will be serviced normally. If the global mask bit (bit 21) is set to "1", no interrupts are serviced. However, the source's pending bit is set if the interrupt is generated. When the global mask bit has been set to "0", the interrupt is serviced.

## INTERRUPT SOURCES

The 21 interrupt sources in the S3C4510B interrupt structure are listed, in brief, as follows:

**Table 13-1. S3C4510B Interrupt Sources**

Index Values	Interrupt Sources
[20]	I <sup>2</sup> C-bus interrupt
[19]	Ethernet controller MAC Rx interrupt
[18]	Ethernet controller MAC Tx interrupt
[17]	Ethernet controller BDMA Rx interrupt
[16]	Ethernet controller BDMA Tx interrupt
[15]	HDLC channel B Rx interrupt
[14]	HDLC channel B Tx interrupt
[13]	HDLC channel A Rx interrupt
[12]	HDLC channel A Tx interrupt
[11]	Timer 1 interrupt
[10]	Timer 0 interrupt
[9]	GDMA channel 1 interrupt
[8]	GDMA channel 0 interrupt
[7]	UART 1 receive and error interrupt
[6]	UART 1 transmit interrupt
[5]	UART 0 receive and error interrupt
[4]	UART 0 transmit interrupt
[3]	External interrupt 3
[2]	External interrupt 2
[1]	External interrupt 1
[0]	External interrupt 0

## INTERRUPT CONTROLLER SPECIAL REGISTERS

### INTERRUPT MODE REGISTER

Bit settings in the interrupt mode register, INTMOD, specify if an interrupt is to be serviced as a fast interrupt (FIQ) or a normal interrupt (IRQ).

**Table 13-2. INTMOD Register**

Register	Offset Address	R/W	Description	Reset Value
INTMOD	0x4000	R/W	Interrupt mode register	0x00000000

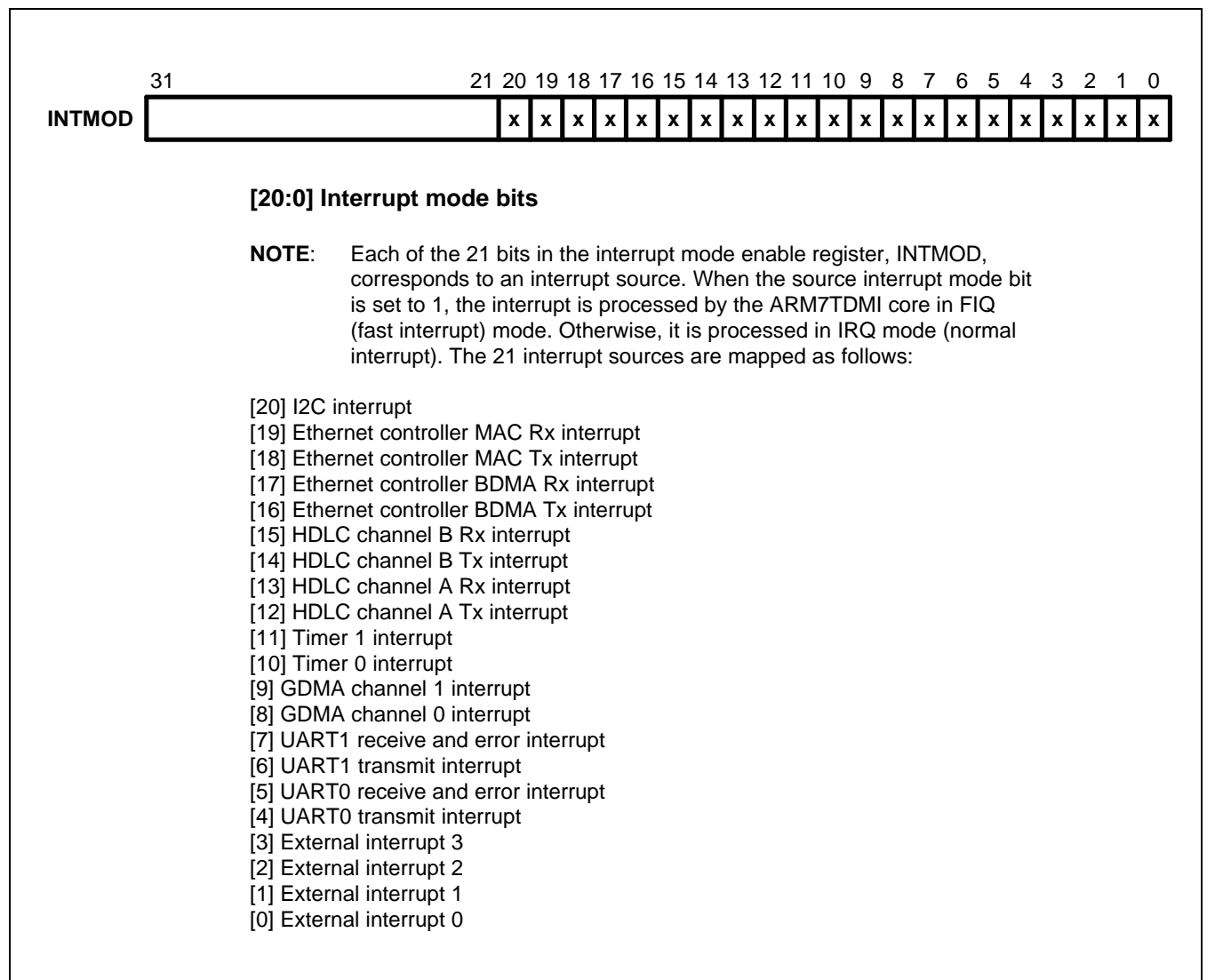

**Figure 13-1. Interrupt Mode Register (INTMOD)**





**INTERRUPT PRIORITY REGISTERS**

The interrupt priority registers, INTPRI0–INTPRI5, contain information about which interrupt source is assigned to the pre-defined interrupt priority field. Each INTPRI $n$  register value determines the priority of the corresponding interrupt source. The lowest priority value is priority 0, and the highest priority value is priority 20.

The index value of each interrupt source is written to one of the above 21 positions (see Figure 13-4). The position value then becomes the written interrupt's priority value. The index value of each interrupt source is listed in Table 13-1.

**Table 13-5. Interrupt Priority Register Overview**

Register	Offset Address	R/W	Description	Reset Value
INTPRI0	0x400C	R/W	Interrupt priority register 0	0x03020100
INTPRI1	0x4010	R/W	Interrupt priority register 1	0x07060504
INTPRI2	0x4014	R/W	Interrupt priority register 2	0x0B0A0908
INTPRI3	0x4018	R/W	Interrupt priority register 3	0x0F0E0D0C
INTPRI4	0x401C	R/W	Interrupt priority register 4	0x13121110
INTPRI5	0x4020	R/W	Interrupt priority register 5	0x00000014

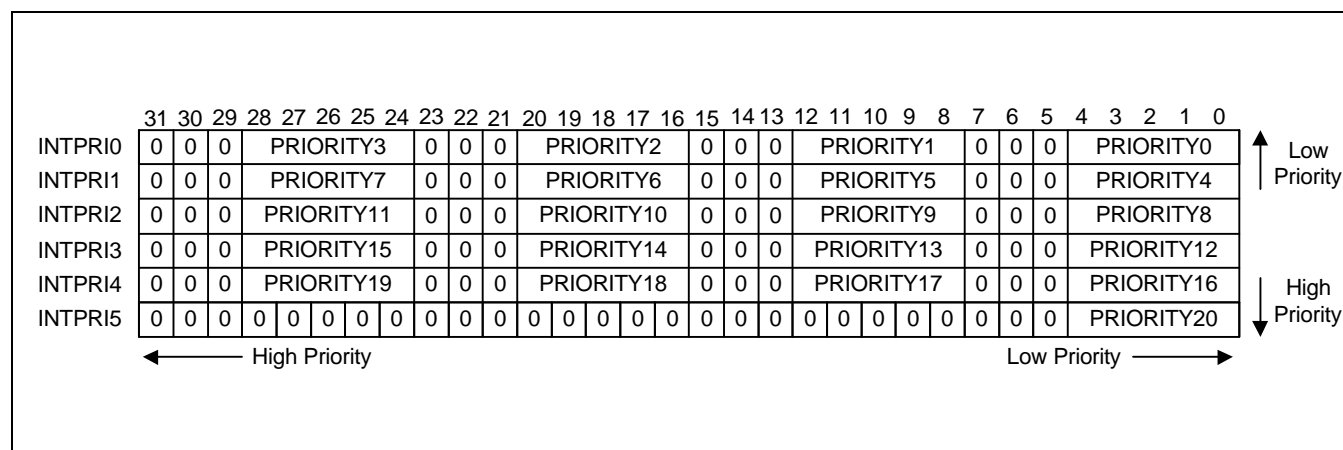

**Figure 13-4. Interrupt Priority Register (INTPRI $n$ )**

## INTERRUPT OFFSET REGISTER

The interrupt offset register, INTOFFSET, contains the interrupt offset address of the interrupt, which has the highest priority among the pending interrupts. The content of the interrupt offset address is "bit position value of the interrupt source << 2".

If all interrupt pending bits are "0" when you read this register, the return value is "0x00000054".

This register is valid only under the IRQ or FIQ mode in the ARM7TDMI. In the interrupt service routine, you should read this register before changing the CPU mode.

INTOSET\_FIQ/INTOSET\_IRQ register can be used to get the highest priority interrupt without CPU mode change. Other usages are similar to INTOFFSET.

### NOTE

If the lowest interrupt priority (priority 0) is pending, the INTOFFSET value will be "0x00000000". The reset value will, therefore, be changed to "0x00000054" (to be differentiated from interrupt pending priority 0).

**Table 13-6. INTOFFSET Register**

Register	Offset Address	R/W	Description	Reset Value
INTOFFSET	0x4024	R	Interrupt offset register	0x00000054
INTOSET_FIQ	0x4030	R	FIQ interrupt offset register	0x00000054
INTOSET_IRQ	0x4034	R	IRQ interrupt offset register	0x00000054

**INTERRUPT PENDING BY PRIORITY REGISTER**

The interrupt pending by priority register, INTPNDPRI, contains interrupt pending bits, which are re-ordered by the INTPRIn register settings. INTPNDPRI[20] is mapped to the interrupt source of whichever bit index is written into the priority 20 field of the INTPRIn registers.

This register is useful for testing. To validate the interrupt pending by priority value, you can obtain the highest priority pending interrupt from the interrupt offset register, INTOFFSET.

**Table 13-7. INTPNDPRI Register**

Register	Offset Address	R/W	Description	Reset Value
INTPNDPRI	0x4028	R	Interrupt pending by priority	0x00000000

**INTERRUPT PENDING TEST REGISTER**

The interrupt pending test register, INTPNDTST, is used to set or clear INTPND and INTPNDPRI. If user writes data to this register, it is written into both the INTPND register and INTPNDPRI register. The interrupt pending test register, INTPNDTST, is also useful for testing.

For INTPND, the same bit position is updated with the new coming data. For INTPNDPRI, the mapping bit position by INTPRIn registers is updated with the new coming data to keep with the contents of the INTPND register.

**Table 13-8. INTPNDTST Register**

Register	Offset Address	R/W	Description	Reset Value
INTPNDTST	0x402C	W	Interrupt pending test register	0x00000000



# 14 ELECTRICAL DATA

## OVERVIEW

This chapter describes the S3C4510B and S3C4510X electrical data.

## ABSOLUTE MAXIMUM RATINGS

Table 14-1. Absolute Maximum Ratings

Parameter	Symbol	Rating		Units
Supply Voltage	$V_{DD}/V_{DDA}$	– 0.3 to 3.8		V
DC input Voltage	$V_{IN}$	3.3 V I/O	– 0.3 to $V_{DD} + 0.3$	V
		5 V-tolerant	– 0.3 to 5.5	
DC input current	$I_{IN}$	$\pm 10$		mA
Operating temperature	$T_{OPR}$	0 to 70		°C
Storage temperature	$T_{STG}$	– 40 to 125		°C

## ABSOLUTE MAXIMUM RATINGS

Table 14-2. Recommended Operating Conditions

Parameter	Symbol	Rating	Units
Supply Voltage	$V_{DD}/V_{DDA}$	3.0 to 3.6	V
Oscillator frequency	$f_{OSC}$	upto 50	MHz
External loop filter capacitance	$L_F$	820	pF
Commercial temperature	$T_A$	0 to 70	°C

**NOTE:** It is strongly recommended that all the supply pins ( $V_{DD}/V_{DDA}$ ) be powered from the same source to avoid power latch-up.

## D.C. ELECTRICAL CHARACTERISTICS

Table 14-3. D.C Electrical Characteristics

 $V_{DD} = 3.3 \text{ V} \pm 0.3 \text{ V}$ ,  $V_{EXT} = 5 \pm 0.25 \text{ V}$ ,  $T_A = 0 \text{ to } 70 \text{ }^\circ\text{C}$  (in case of 5 V-tolerant I/O)

Parameter		Symbol	Conditions	Min	Typ	Max	Unit	
High level input voltage	LVC MOS interface	$V_{IH}^{(1)}$	–	2.0	–	–	V	
Low level input voltage	LVC MOS interface	$V_{IL}^{(1)}$	–	–	–	0.8	V	
Switching threshold		VT	LVC MOS	–	1.4	–	V	
Schmitt trigger positive-going threshold		VT+	LVC MOS	–	–	2.0		
Schmitt trigger negative-going threshold		VT–	LVC MOS	0.8	–	–		
High level input current	Input buffer	$I_{IH}$	$V_{IN} = V_{DD}$	– 10	–	10	$\mu\text{A}$	
	Input buffer with pull-up			10	30	60		
Low level input current	Input buffer	$I_{IL}$	$V_{IN} = V_{SS}$	– 10	–	10	$\mu\text{A}$	
	Input buffer with pull-down			– 60	– 30	– 10		
High level output voltage	Type B1 to B16 <sup>(2)</sup>	$V_{OH}$	$I_{OH} = -1 \mu\text{A}$	$V_{DD} - 0.05$	–	–	V	
	Type B1							2.4
	Type B2							
	Type B4							
	Type B6							
Low level output voltage	Type B1 to B16 <sup>(2)</sup>	$V_{OL}$	$I_{OL} = 1 \mu\text{A}$			0.05	V	
	Type B1							0.4
	Type B2							
	Type B4							
	Type B6							
Tri-state output leakage current		$I_{OZ}$	$V_{OUT} = V_{SS}$ or $V_{DD}$	– 10		10	$\mu\text{A}$	
Maximum operating current		$I_{DD}$	$V_{DD} = 3.6 \text{ V}$ , $f_{MCLK} = 50\text{MHz}$			230	mA	

## NOTES:

- All 5 V-tolerant inputs have less than 0.2 V hysteresis.
- Type B1 means 1 mA output driver cells, and Type B6/B24 means 6 mA/24 mA output driver cells.

Table 14-4. A.C Electrical Characteristics for S3C4510X

(T<sub>A</sub> = 0 to 70 °C, V<sub>DD</sub> = 3.0 V to 3.6 V)

Signal Name	Description	Min	Max	Edge
tMCLKOd	MCLKO delay for Internal Positive Edge Clock (MCLK)	4.03	10.57	P
tEMZ	Memory Control Signal High-Z Time	4.99	12.02	N
tEMRs	ExtMREQ Setup Time		3.90	P
tEMRh	ExtMREQ Hold Time	0		P
tEMAr	ExtMACK Rising Edge Delay Time	9.55	23.30	N
tEMAf	ExtMACK Falling Edge Delay Time	9.30	22.70	N
tADDRh	Address Hold Time	4.75	11.50	N
tADDRd	Address Delay Time	6.76	16.53	N
tNRCS	ROM/SRAM/Flash Bank Chip Select Delay Time	3.24	7.90	N
tNROE	ROM/SRAM or External I/O Bank Output Enable Delay	3.81	9.24	N
tNWB	ROM/SRAM or External I/O Bank Write Byte Enable Delay	3.36	8.13	P
tRDs	Read Data Setup Time		10.82	N
tRDh	Read Data Hold Time	0		N
tWDd	Write Data Delay Time (SRAM or External I/O) (ref:nWBE)	1.86	4.49	N
tWDh	Write Data Hold Time (SRAM or External I/O) (ref:MCLK)	2.05	4.86	N
tNRASf	DRAM Row Address Strobe Active Delay	3.53	8.59	P
tNRASr	DRAM Row Address Strobe Release Delay	4.95	11.99	N
tNCASf	DRAM Column Address Strobe Read Active Delay	3.58	8.70	P
tNCASr	DRAM CAS Signal Release Read Delay Time	3.57	8.62	P
tNCASwf	DRAM Column Address Strobe Write Active Delay	3.60	8.72	N
tNCASwr	DRAM CAS Signal Release Write Delay Time	3.62	8.73	N
tNDWE	DRAM Bank Write Enable Delay Time	3.93	9.54	N
tNDOE	DRAM Bank Out Enable Delay Time	3.80	9.26	N
tNECS	External I/O Bank Chip Select Delay Time	3.58	8.74	N
tWDDd	DRAM Write Data Delay Time (DRAM)	4.96	11.97	N
tWDDh	DRAM Write Data Hold Time (DRAM)	2.70	6.42	N
tWs	External Wait Setup Time		4.82	N
tWh	External Wait Hold Time	0		N

**NOTE:** The edge (N) is calculated from SCLK(MCLK) falling and (P) is rising.

Table 14-5. A.C Electrical Characteristics for S3C4510B

(T<sub>A</sub> = 0 to 70 °C, V<sub>DD</sub> = 3.0 V to 3.6 V)

Signal Name	Description	Min	Max	Edge
tMCLKOd	MCLKO delay for Internal Positive Edge Clock(MCLK)	4.07	9.37	P
tEMZ	Memory Control Signal High-Z Time	5.08	11.76	N
tEMRs	ExtMREQ Setup Time		6.31	P
tEMRh	ExtMREQ Hold Time	0		P
tEMAr	ExtMACK Rising Edge Delay Time	12.19	28.54	N
tEMAf	ExtMACK Falling Edge Delay Time	9.33	21.87	N
tADDRh	Address Hold Time	5.16	12.08	N
tADDRd	Address Delay Time	6.13	14.35	N
tNRCS	ROM/SRAM/Flash Bank Chip Select Delay Time	3.96	9.29	N
tNROE	ROM/SRAM or External I/O Bank Output Enable Delay	3.82	8.96	N
tNWB	ROM/SRAM or External I/O Bank Write Byte Enable Delay	4.70	11.13	P
tRDs	Read Data Setup Time		12.46	N
tRDh	Read Data Hold Time	0		N
tWDd	Write Data Delay Time (SRAM or External I/O) (ref:nWBE)	2.50	5.65	N
tWDh	Write Data Hold Time (SRAM or External I/O) (ref:MCLK)	1.94	4.45	N
tNRASf	DRAM Row Address Strobe Active Delay	3.84	9.00	P
tNRASr	DRAM Row Address Strobe Release Delay	5.70	13.31	N
tNCASf	DRAM Column Address Strobe Read Active Delay	3.77	8.84	P
tNCASr	DRAM CAS Signal Release Read Delay Time	4.23	9.88	P
tNCASwf	DRAM Column Address Strobe Write Active Delay	3.78	8.86	N
tNCASwr	DRAM CAS Signal Release Write Delay Time	4.27	9.99	N
tNDWE	DRAM Bank Write Enable Delay Time	4.81	11.25	N
tNDOE	DRAM Bank Out Enable Delay Time	4.15	9.71	N
tNECS	External I/O Bank Chip Select Delay Time	4.12	9.63	N
tWDDd	DRAM Write Data Delay Time (DRAM)	7.00	16.32	N
tWDDh	DRAM Write Data Hold Time (DRAM)	3.27	7.58	N
tWs	External Wait Setup Time		4.46	N
tWh	External Wait Hold Time	0		N

**NOTE:** The edge (N) is calculated from SCLK(MCLK) falling and (P) is rising.

# 15

## MECHANICAL DATA

### OVERVIEW

This section describes the mechanical data for the S3C4510B 208-pin QFP package.

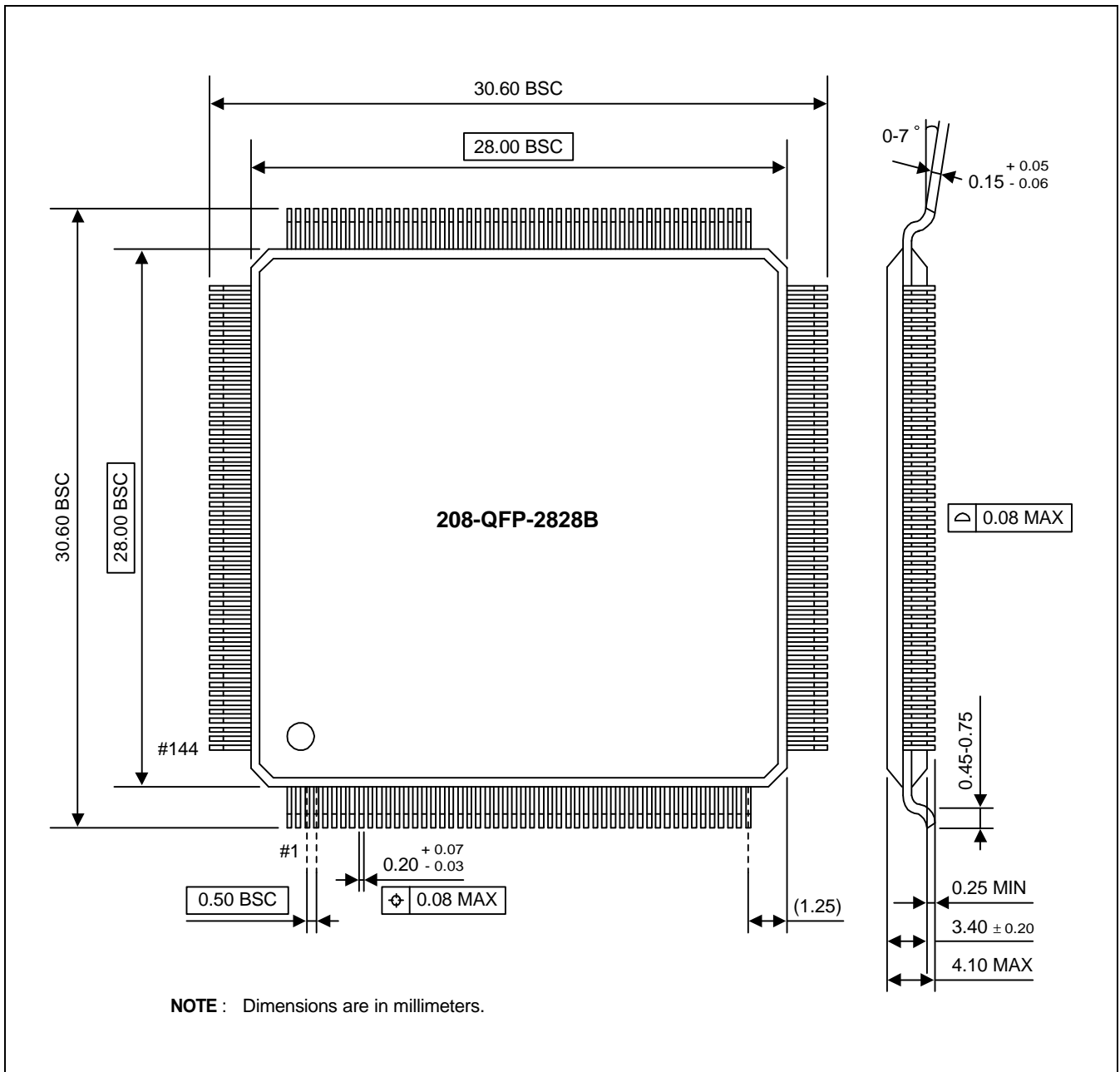

Figure 15-1. 208-QFP-2828B Package Dimensions

# APPENDIX A

## TEST ACCESS PORT

This section describes relevant sections of the IEEE Standard 1149.1 Compatible Test Access Port (TAP). This standard applies to the Test Access Port and Boundary Scan (JTAG) specification, which is supported by the S3C4510B microcontroller.

In test mode, package pads are monitored by the serial scan circuitry. This is done to support connectivity testing during manufacturing, as well as system diagnostics. JTAG control is not used to drive internal data out of the S3C4510B.

To conform with IEEE 1149.1, the S3C4510B has a TAP controller, an instruction register, a bypass register, and an ID register. These components are described in detail below.

**TAP CONTROLLER**

The TAP controller is responsible for interpreting the sequence of logical values on the TMS signal. It is a synchronous state machine which controls the JTAG logic (see Figure B-1). In Figure B-1, the value shown next to each curved arrow represents the value of the TMS signal as it is sampled on the rising edge of the TCK signal.

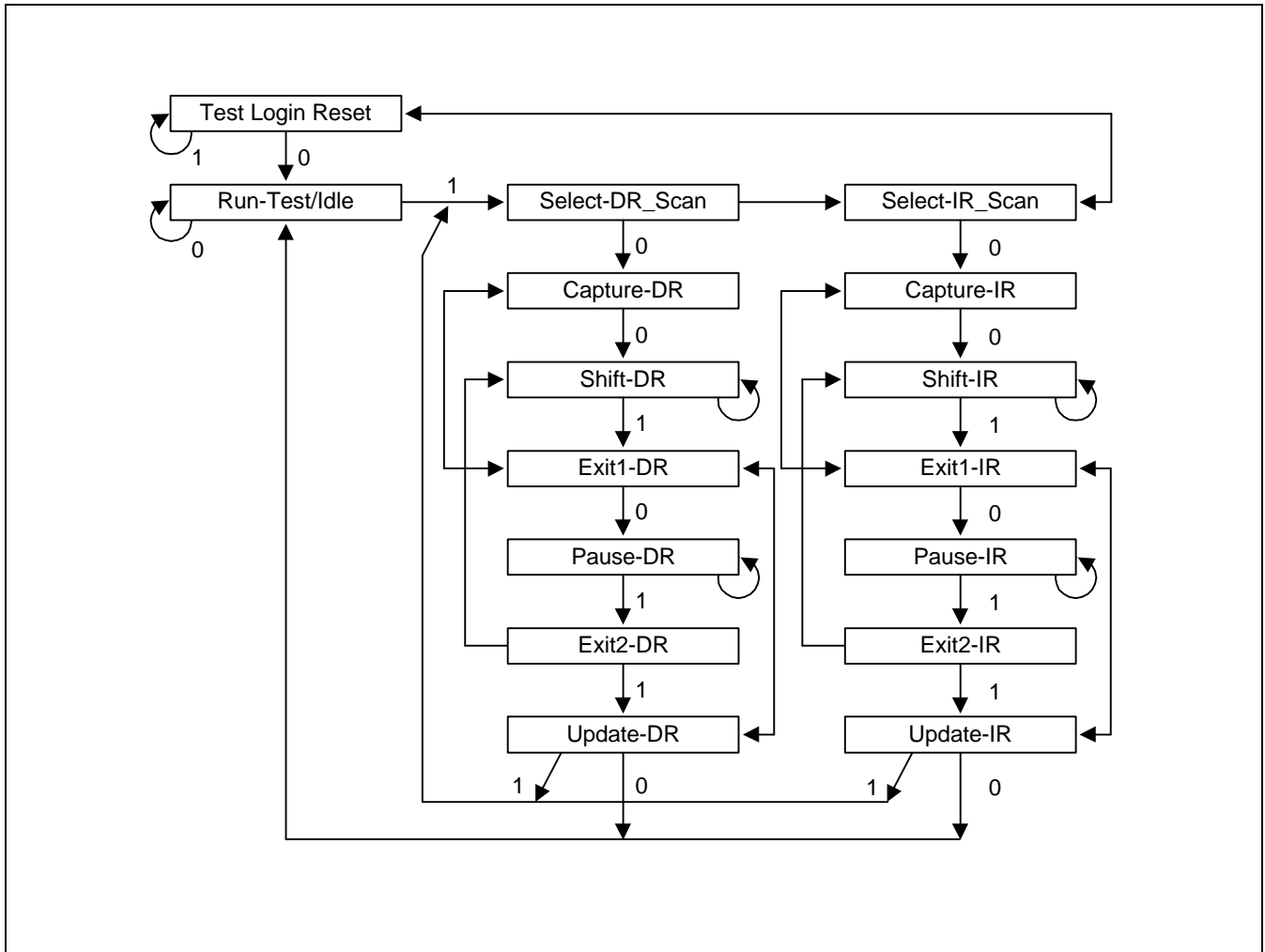

**Figure A-1. TAP Controller State Machine**



## BOUNDARY SCAN REGISTER

The S3C4510B scan chain implementation uses a 233-bit boundary scan register. This register contains bits for all device signals and clock pins, and for associated control signals.

All bi-directional pins have two register bits in the boundary scan register for pin data. Each pin is controlled by an associated control bit in the boundary scan register. The twenty-three bits in the boundary scan register define the output enable signals for associated groups of bi-directional and tri-stateable pins. The control bits and their bit positions are listed in Table B-1.

**Table A-1. Boundary Scan Control Bits**

Name	Bit Number	Name	Bit Number	Name	Bit Number
penb [17]	9	penb [9]	33	penb [1]	57
penb [16]	12	penb [8]	36	penb [0]	60
penb [15]	15	penb [7]	39	d_enb	127
penb [14]	18	penb [6]	42	dis_bus	184
penb [13]	21	penb [5]	45	mdio_oe	192
penb [12]	24	penb [4]	48	txcben	211
penb [11]	27	penb [3]	51	txcaen	222
penb [10]	30	penb [2]	54		

## BOUNDARY SCAN DEFINITIONS

The boundary scan bit definitions are listed in Tables B-2 through B-5:

- The first column in the table defines the bit's ordinal position in the boundary scan register. The shift register cell nearest TDO (that is, the first bit to be shifted out) is defined as bit 0. The last bit to be shifted out is bit number 232.
- The second column refers to one of the four S3C4510B cell types: jtin1, jtbi1, and jtout1.
- The third column lists the pin name of pin-related cells or defines the name of bi-directional control register bits.
- The fourth column lists the pin type. TS-Output indicates a tri-stateable output pin, and OD-I/O denotes an open-drain bi-directional pin.
- The fifth column indicates the associated boundary scan register control bit for bi-directional, tri-state output.

Table A-2. Boundary Scan Definitions (Page 1)

Bit Number	Cell Type	Pin/Cell Name	Pin Type	Output CTL Cell	Bit Number	Cell Type	Pin/Cell Name	Pin Type	Output CTL Cell
0	jtin 1	UARXD1	Input	–	32	jtbi1	P[10]	Input	–
1	jtout 1	nUADSR0	Output	–	33	jtout1	penb[9]	–	–
2	jtout 1	UATXD0	Output	–	34	jtbi1	P[9]o	TS-Output	penb[9]
3	jtin 1	UADTR0	Input	–	35	jtbi1	P[9]i	Input	–
4	jtin 1	UARXD0	Input	–	36	jtout1	penb[8]	–	–
5	jtbi 1	SDA	OD-Output	–	37	jtbi1	P[8]	TS-Output	–
6	jtbi 1	SDA	OD-Input	–	38	jtbi1	P[8]	Input	–
7	jtbi 1	SCL	OD-Output	–	39	jtout1	penb[7]	–	–
8	jtbi 1	SCL	OD-Input	–	40	jtbi1	P[7]	TS-Output	penb[7]
9	jtout 1	pend[17]	–	–	41	jtbi1	P[7]	Input	–
10	jtbi 1	P[17]	TS-Output	penb[17]	42	jtout1	penb[6]	–	–
11	jtbi 1	P[17]	Input	–	43	jtbi1	P[6]	TS-Output	penb[6]
12	jtout 1	penb[16]	–	–	44	jtbi1	P[6]	Input	–
13	jtbi 1	P[16]	TS-Output	penb[16]	45	jtout1	penb[5]	–	–
14	jtbi 1	P[16]	Input	–	46	jtbi1	P[5]	TS-Output	penb[5]
15	jtout 1	penb[15]	–	–	47	jtbi1	P[5]	Input	–
16	jtbi 1	P[15]	TS-Output	penb[15]	48	jtout1	penb[4]	–	–
17	jtbi 1	P[15]	Input	–	49	jtbi1	P[4]	TS-Output	penb[4]
18	jtout 1	penb[14]	–	–	50	jtbi1	P[4]	Input	–
19	jtbi 1	P[14]	TS-Output	penb[14]	51	jtout1	penb[3]	–	–
20	jtbi 1	P[14]	Input	–	52	jtbi1	P[3]	TS-Output	penb[3]
21	jtout 1	penb[13]	–	–	53	jtbi1	P[3]	Input	–
22	jtbi 1	P[13]	TS-Output	penb[13]	54	jtout1	penb[2]	–	–
23	jtbi 1	P[13]	Input	–	55	jtbi1	P[2]	TS-Output	penb[2]
24	jtout 1	penb[12]	–	–	56	jtbi1	P[2]	Input	–
25	jtbi 1	P[12]	TS-Output	penb[12]	57	jtout1	penb[1]	–	–
26	jtbi 1	P[12]	Input	–	58	jtbi1	P[1]o	TS-Output	penb[1]
27	jtout 1	penb[11]	–	–	59	jtbi1	P[1]i	Input	–
28	jtbi 1	P[11]	TS-Output	penb[11]	60	jtout1	penb[0]	–	–
29	jtbi 1	P[11]	Input	–	61	jtbi1	P[0]	TS-Output	penb[0]
30	jtout 1	penb[10]	–	–	62	jtbi1	P[0]	Input	–
31	jtbi 1	P[10]	TS-Output	penb[10]	63	jtbi1	XDATA[31]	TS-Output	denb

Table A-3. Boundary Scan Definitions (Page 2)

Bit Number	Cell Type	Pin/Cell Name	Pin Type	Output CTL Cell	Bit Number	Cell Type	Pin/Cell Name	Pin Type	Output CTL Cell
64	jtbi1	XDATA[31]	Input	–	96	jtbi1	XDATA[15]	Input	–
65	jtbi1	XDATA[30]	TS-Output	denb	97	jtbi1	XDATA[14]	TS-Output	denb
66	jtbi1	XDATA[30]	Input	–	98	jtbi1	XDATA[14]	Input	–
67	jtbi1	XDATA[29]	TS-Output	denb	99	jtbi1	XDATA[13]	TS-Output	denb
68	jtbi1	XDATA[29]	Input	–	100	jtbi1	XDATA[13]	Input	–
69	jtbi1	XDATA[28]	TS-Output	denb	101	jtbi1	XDATA[12]	TS-Output	denb
70	jtbi1	XDATA[28]	Input	–	102	jtbi1	XDATA[12]	Input	–
71	jtbi1	XDATA[27]	TS-Output	denb	103	jtbi1	XDATA[11]	TS-Output	denb
72	jtbi1	XDATA[27]	Input	–	104	jtbi1	XDATA[11]	Input	–
73	jtbi1	XDATA[26]	TS-Output	denb	105	jtbi1	XDATA[10]	TS-Output	denb
74	jtbi1	XDATA[26]	Input	–	106	jtbi1	XDATA[10]	Input	–
75	jtbi1	XDATA[25]	TS-Output	denb	107	jtbi1	XDATA[9]	TS-Output	denb
76	jtbi1	XDATA[25]	Input	–	108	jtbi1	XDATA[9]	Input	–
77	jtbi1	XDATA[24]	TS-Output	denb	109	jtbi1	XDATA[8]	TS-Output	denb
78	jtbi1	XDATA[24]	Input	–	110	jtbi1	XDATA[8]	Input	–
79	jtbi1	XDATA[23]	TS-Output	denb	111	jtbi1	XDATA[7]	TS-Output	denb
80	jtbi1	XDATA[23]	Input	–	112	jtbi1	XDATA[7]	Input	–
81	jtbi1	XDATA[22]	TS-Output	denb	113	jtbi1	XDATA[6]	TS-Output	denb
82	jtbi1	XDATA[22]	Input	–	114	jtbi1	XDATA[6]	Input	–
83	jtbi1	XDATA[21]	TS-Output	denb	115	jtbi1	XDATA[5]	TS-Output	denb
84	jtbi1	XDATA[21]	Input	–	116	jtbi1	XDATA[5]	Input	–
85	jtbi1	XDATA[20]	TS-Output	denb	117	jtbi1	XDATA[4]	TS-Output	denb
86	jtbi1	XDATA[20]	Input	–	118	jtbi1	XDATA[4]	Input	–
87	jtbi1	XDATA[19]	TS-Output	denb	119	jtbi1	XDATA[3]	TS-Output	denb
88	jtbi1	XDATA[19]	Input	–	120	jtbi1	XDATA[3]	Input	–
89	jtbi1	XDATA[18]	TS-Output	denb	121	jtbi1	XDATA[2]	TS-Output	denb
90	jtbi1	XDATA[18]	Input	–	122	jtbi1	XDATA[2]	Input	–
91	jtbi1	XDATA[17]	TS-Output	denb	123	jtbi1	XDATA[1]	TS-Output	denb
92	jtbi1	XDATA[17]	Input	–	124	jtbi1	XDATA[1]	Input	–
93	jtbi1	XDATA[16]	TS-Output	denb	125	jtbi1	XDATA[0]	TS-Output	denb
94	jtbi1	XDATA[16]	Input	–	126	jtbi1	XDATA[0]	Input	–
95	jtbi1	XDATA[15]	TS-Output	denb	127	jtout1	denb	–	–

Table A-4. Boundary Scan Definitions (Page 3)

Bit Number	Cell Type	Pin/Cell Name	Pin Type	Output CTL Cell	Bit Number	Cell Type	Pin/Cell Name	Pin Type	Output CTL Cell
128	jtout1	PADDR[21]	TS-O	dis_bus	160	jtout1	nCAQS[0]	TS-O	dis_bus
129	jtout1	PADDR[20]	TS-O	dis_bus	161	jtout1	nRAS[3]	TS-O	dis_bus
130	jtout1	PADDR[19]	TS-O	dis_bus	162	jtout1	nRAS[2]	TS-O	dis_bus
131	jtout1	PADDR[18]	TS-O	dis_bus	163	jtout1	nRAS[1]	TS-O	dis_bus
132	jtout1	PADDR[17]	TS-O	dis_bus	164	jtout1	nRAS[0]	TS-O	dis_bus
133	jtout1	PADDR[16]	TS-O	dis_bus	165	jtout1	nRCS[5]	TS-O	dis_bus
134	jtout1	PADDR[15]	TS-O	dis_bus	166	jtout1	nRCS[4]	TS-O	dis_bus
135	jtout1	PADDR[14]	TS-O	dis_bus	167	jtout1	nRCS[3]	TS-O	dis_bus
136	jtout1	PADDR[13]	TS-O	dis_bus	168	jtout1	nRCS[2]	TS-O	dis_bus
137	jtout1	PADDR[12]	TS-O	dis_bus	169	jtout1	nRCS[1]	TS-O	dis_bus
138	jtout1	PADDR[11]	TS-O	dis_bus	170	jtin1	CLKSEL	Input	–
139	jtout1	PADDR[10]	TS-O	dis_bus	171	jtin1	nRESET	Input	–
140	jtout1	PADDR[9]	TS-O	dis_bus	172	jtck	MCLK	Input	–
141	jtout1	PADDR[8]	TS-O	dis_bus	173	jtout1	MCLKO	Output	–
142	jtout1	PADDR[7]	TS-O	dis_bus	174	jtin1	CLKOEN	Input	–
143	jtout1	PADDR[6]	TS-O	dis_bus	175	jtout1	nRCS[0]	TS-O	dis_bus
144	jtout1	PADDR[5]	TS-O	dis_bus	176	jtin1	BOSIZE[1]	Input	–
145	jtout1	PADDR[4]	TS-O	dis_bus	177	jtin1	BOSIZE[0]	Input	–
146	jtout1	PADDR[3]	TS-O	dis_bus	178	jtout1	nOE	TS-O	dis_bus
147	jtout1	PADDR[2]	TS-O	dis_bus	179	jtin1	nEWAIT	Input	–
148	jtout1	PADDR[1]	TS-O	dis_bus	180	jtout	nECS[3]	TS-O	dis_bus
149	jtout1	PADDR[0]	TS-O	dis_bus	181	jtout1	nECS[2]	TS-O	dis_bus
150	jtout1	EXTMACK	Output	–	182	jtout1	nECS[1]	TS-O	dis_bus
151	jtin1	EXTMREQ	TS-O	–	183	jtout1	nECS[0]	TS-O	dis_bus
152	jtout1	nWBE[3]	TS-O	dis_bus	184	jtout1	dis_bus	–	–
153	jtout1	nWBE[2]	TS-O	dis_bus	185	jtin1	UCLK	Input	–
154	jtout1	nWBE[1]	TS-O	dis_bus	186	jtin1	TMODE	Input	–
155	jtout1	nWBE[0]	TS-O	dis_bus	187	jtout1	MDC	Output	–
156	jtout1	nDWE	TS-O	dis_bus	188	jtin1	LITTLE	–	–
157	jtout1	nCAS[3]	TS-O	dis_bus	189	jtout1	mdio_oe	–	–
158	jtout1	nCAS[2]	TS-O	dis_bus	190	jtbi1	MDIO	TS-O	mdio_oe
159	jtout1	nCAS[1]	TS-O	dis_bus	191	jtbi1	MDIO	Input	–

Table A-5. Boundary Scan Definitions (Page 4)

Bit Number	Cell Type	Pin/Cell Name	Pin Type	Output CTL Cell	Bit Number	Cell Type	Pin/Cell Name	Pin Type	Output CTL Cell
192	jtout1	TX_EN/ TXEN_10M	Output	–	213	jtin1	nDCDB	Input	–
193	jtin1	TX_CLK/ TXCLK_10 M	Input	–	214	jtin1	nCTSB	Input	–
194	jtout1	TX_ERR/ PCOMP_1 0M	Output	–	215	jtout1	TXDB	Output	–
195	jtout1	TXD3	Output	–	216	jtout1	nRTSB	Output	–
196	jtout1	TXD2	Output	–	217	jtin1	RXDB	Input	–
197	jtout1	TXD1/ LOOP10	Output	–	218	jtout1	nDTRB	Output	–
198	jtout1	TXD0/ TXD_10M	Output	–	219	jtout1	txcaen	–	–
199	jtin1	COL/ COL_10M	Input	–	220	jtbi1	TXCA	Output	txcaen
200	jtin1	RX_CLK/ RXCLK_10 M	Input	–	221	jtbi1	TXCA	Input	–
201	jtin1	RX_ERR	Input	–	222	jtout1	nSYNCA	Output	–
202	jtin1	RXD3	Input	–	223	jtin1	RXCA	Input	–
203	jtin1	RXD2	Input	–	224	jtin1	nDCDA	Input	–
204	jtin1	RXD1	Input	–	225	jtin1	nCTSA	Input	–
205	jtin1	RXD0/ RXD_10M	Input	–	226	jtout1	TXDA	Output	–
206	jtin1	RX_DV/ LINK10	Input	–	227	jtout1	nRTSA	Output	–
207	jtin1	CRS/ CRS_10M	Input	–	228	jtin1	RXDA	Input	–
208	jtout1	txcben	–	–	229	jtout1	nDTRA	Output	–
209	jtbi1	TXCB	TS-Out	txcben	230	jtout1	nUADSR1	Output	–
210	jtbi1	TXCB	Input	–	231	jtout1	UATXD1	Output	–
211	jtout1	nSYNCB	Output	–	232	jtin1	UADTR1	Input	–
212	jtin1	RXCB	Input	–					

NOTE : TS-O is tri-state output.

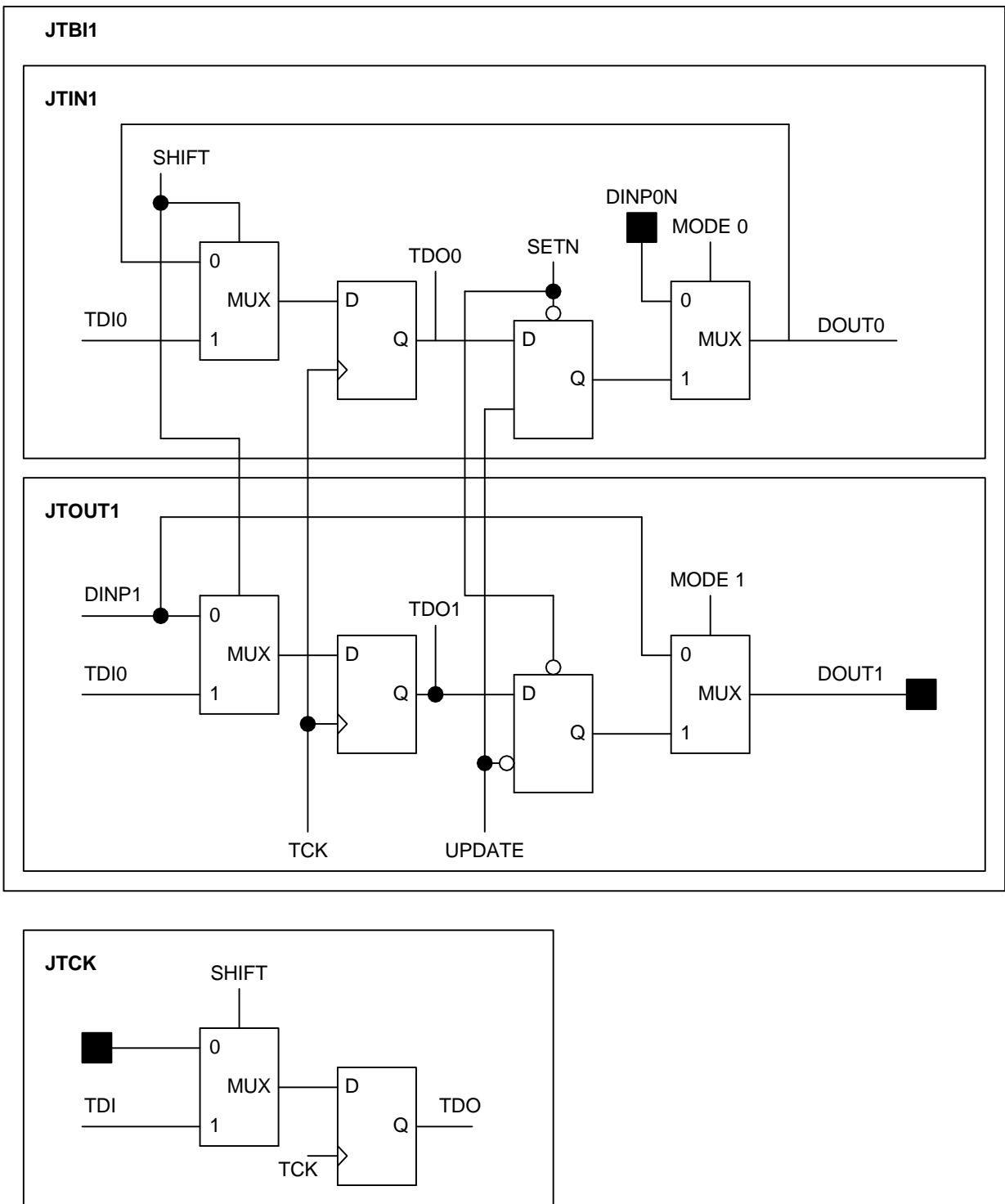

Figure A-2. S3C4510B Scan Cells

## INSTRUCTION REGISTER

The instruction register is four bits in length. There is no parity bit. The fixed value '0001' is loaded into the instruction register during the CAPTURE-IR controller state.

The TAP machines supports the following public instructions. However, the S3C4510B boundary scan logic only supports EXTEST, IDCODE, BYPASS, and SAMPLE/PRELOAD instructions. The remaining instructions are used for ARM7TDMI core testing and debugging.

**Table A-6. Public Instructions**

Instruction	Binary Code
EXTEST	0000
SCAN_N	0010
INTEST	1100
IDCODE	1110
BYPASS	1111
CLAMP	0101
HIGHZ	0111
CLAMPZ	1001
SAMPLE/PRELOAD	0011
RESTART	0100

```
--
Samsung Electronics Co.
-- S3C4510B BSDL
--
-- Version 1.1 01-27-99
-- Revision List:
-- 1) Pin name NC changed to LITTLE
-- 2) 1194 -> 1149
-- Package Type: QFP2828B
--
```

entity S3C4510B is

```
generic (PHYSICAL_PIN_MAP : string := "QFP2828B");
```

```
port (
    nUADTR1      : in    bit;
    UATXD1       : outbit;
    nUADSR1      : outbit;

    nDTRA        : outbit;
    RXDA         : inbit;
    nRTSA        : outbit;
    TXDA         : outbit;
    nCTSA        : inbit;
    nDCDA        : inbit;
    RXCA         : inbit;
    nSYNCA       : outbit;
    TXCA         : inoutbit;
    nDTRB        : outbit;
    RXDB         : inbit;
    nRTSB        : outbit;
    TXDB         : outbit;
    nCTSB        : inbit;
    nDCDB        : inbit;
    RXCB         : inbit;
    nSYNCB       : outbit;
    TXCB         : inoutbit;
```



---

CRS_CRS_10M	: inbit;
RX_DV_LINK10	: inbit;
RXD	: inbit_vector(0 to 3);
RX_ERR	: inbit;
RX_CLK_RXCLK_10M	: inbit;
COL_COL_10M	: inbit;
TXD	: outbit_vector(0 to 3);
TX_ERR_PCOMP_10M	: outbit;
TX_CLK_TXCLK_10M	: inbit;
TX_EN_TXEN_10M	: outbit;
MDIO	: inoutbit;
LITTLE	: inbit;
MDC	: outbit;
TCK	: inbit;
TMS	: inbit;
TDI	: inbit;
TDO	: outbit;
nTRST	: inbit;
TMODE	: inbit;
UCLK	: inbit;
nECS	: outbit_vector(0 to 3);
nEWAIT	: inbit;
nOE	: outbit;
B0SIZE	: inbit_vector(0 to 1);
CLKOEN	: inbit;
MCKO	: outbit;
MCLK	: inbit;
nRESET	: inbit;
CLKSEL	: inbit;
nRCS	: outbit_vector(0 to 5);
nRAS	: outbit_vector(0 to 3);
nCAS	: outbit_vector(0 to 3);
nDWE	: outbit;
nWBE	: outbit_vector(0 to 3);
ExtMREQ	: inbit;
ExtMACK	: outbit;
ADDR	: outbit_vector(0 to 21);
XDATA	: inoutbit_vector(0 to 31);

---

```
P           : inoutbit_vector(0 to 17);
SCL        : inoutbit;
SDA        : inoutbit;
UARXD0     : inbit;
nUADTR0    : inbit;
UATXD0     : outbit;
nUADSR0    : outbit;
UARXD1     : inbit;
VDDP      : linkagebit_vector(0 to 10);
VDDI      : linkagebit_vector(0 to 10);
VSSP      : linkagebit_vector(0 to 11);
VSSI      : linkagebit_vector(0 to 10)
);
```

```
use STD_1149_1_1149.all;
```

```
attribute PIN_MAP of S3C4510B : entity is PHYSICAL_PIN_MAP;
```

```
-- QFP2828B Pin Map
```

```
--
```

```
-- No-connects: 49
```

```
--
```

```
constant QFP2828B : PIN_MAP_STRING :=
```

```
"nUADTR1 : 3, " &
```

```
"UATXD1 : 4, " &
```

```
"nUADSR1 : 5, " &
```

```
"nDTRA : 6, " &
```

```
"RXDA : 7, " &
```

```
"nRTSA : 8, " &
```

```
"TXDA : 9, " &
```

```
"nCTSA : 10, " &
```

```
"nDCDA : 13, " &
```

```
"RXCA : 14, " &
```

```
"nSYNCA : 15, " &
```

```
"TXCA : 16, " &
```

```
"nDTRB : 17, " &
```

```
"RXDB : 18, " &
```

```
"nRTSB : 19, " &
```

```
"TXDB : 20, " &
```

```
"nCTSB : 23, " &
```

```
"nDCDB : 24, " &
```

```
"RXCB : 25, " &
```

```
"nSYNCB : 26, " &
```

```
"TXCB : 27, " &
```

```
"CRS_CRS_10M : 28, " &
```

```
"RX_DV_LINK10 : 29, " &
```

```
"RXD : (30, 33, 34, 35), " &
```

```
"RX_ERR : 36, " &
```

```
"RX_CLK_RXCLK_10M : 37, " &
```

---

```
"COL_COL_10M : 38, " &
"TXD : (39, 40, 43, 44), " &
"TX_ERR_PCOMP_10M : 45, " &
"TX_CLK_TXCLK_10M : 46, " &
"TX_EN_TXEN_10M : 47, " &
"MDIO : 48, " &
"LITTLE : 49, " &
"MDC : 50, " &

"TCK : 58, " &
"TMS : 59, " &
"TDI : 60, " &
"TDO : 61, " &
"nTRST : 62, " &
"TMODE : 63, " &
"UCLK : 64, " &

"nECS : (67, 68, 69, 70), " &

"nEWAIT : 71, " &
"nOE : 72, " &
"B0SIZE : (73, 74), " &

"CLKOEN : 76, " &
"MCLKO : 77, " &
"MCLK : 80, " &
"nRESET : 82, " &
"PCLKSEL : 83, " &

"nRCS : (75, 84, 85, 86, 87, 88), " &
"nRAS : (89, 90, 91, 94), " &
"nCAS : (95, 96, 97, 98), " &
"nDWE : 99, " &
"nWBE : (100, 101, 102, 107), " &

"ExtMREQ : 108, " &
"ExtMACK : 109, " &
-- A0 A1 A2 A3 A4 A5 A6 A7 A8 A9 A10 A11 A12 A13 A14 A15 A16 A17 A18 A19 A20 A21
"ADDR : (110, 111, 112, 113, 114, 115, 116, 117, 120, 121, 122, 123, 124, 125, 126, 127, 128, 129, 132, 133,
134, 135), " &

-- D0 D1 D2 D3 D4 D5 D6 D7 D8 D9 D10 D11 D12 D13 D14 D15 D16 D17 D18 D19 D20
D21 D22 D23 D24 D25 D26 D27 D28 D29 D30 D31
"XDATA : (136, 137, 138, 139, 140, 141, 144, 145, 146, 147, 148, 149, 150, 151, 152, 153, 154, 159, 160,
161,162, 163, 164, 165, 166, 169, 170, 171, 172, 173, 174, 175), " &
```

```
-- P0 P1 P2 P3 P4 P5 P6 P7 P8 P9 P10 P11 P12 P13 P14 P15 P16 P17
"P : (176, 179, 180, 181, 182, 183, 184, 185, 186, 189, 190, 191, 192, 193, 194, 195, 196, 199), " &
"SCL : 200, " &
"SDA : 201, " &
"UARXD0 : 202, " &
"nUADTR0 : 203, " &
"UATXD0 : 204, " &
"nUADSR0 : 205, " &
"UARXD1 : 206, " &
"VDDP : 1, 21, 41, 53, 78, 103, 118, 142, 157, 177, 197, " &
"VDDI : 11, 31, 51, 65, 92, 105, 130, 155, 167, 187, 207, " &
"VSSP : 2, 22, 42, 54, 79, 93, 106, 131, 156, 168, 188, 208, " &
"VSSI : 12, 32, 52, 66, 81, 104, 119, 143, 158, 178, 198 ";
```

attribute TAP\_SCAN\_IN of TDI : signal is true;  
 attribute TAP\_SCAN\_OUT of TDO : signal is true;

attribute TAP\_SCAN\_MODE of TMS : signal is true;

attribute TAP\_SCAN\_RESET of nTRST : signal is true;

attribute TAP\_SCAN\_CLOCK of TCK : signal is true;

attribute INSTRUCTION\_LENGTH of S3C4510B : entity is 4;

attribute INSTRUCTION\_OPCODE of S3C4510B : entity is

```
"EXTEST (0000)," &
"SCAN_N (0010)," &
"INTEST (1100)," &
"IDCODE (1110)," &
"BYPASS (1111)," &
"CLAMP (0101)," &
"HIGHZ (0111)," &
"CLAMPZ (1001)," &
"SAMPLE (0011)," &
"RESTART (0100)";
```

-- S3C4510B's IDCODE is the ARM7TDMI's IDCODE.

attribute REGISTER\_ACCESS of S3C4510B : entity is

```
"0001" &      -- version
"111100" &    -- design center
"0011110000" &      -- sequence number
"11110000111" &    -- Samsung
"1";           -- required by 1149.1
```

attribute REGISTER\_ACCESS of S3C4510B : entity is

```
"IDCODE (IDCODE)," &
"BOUNDARY (INTEST, SAMPLE, EXTEST)," &
"BYPASS (CLAMP, HIGHZ, BYPASS)";
```

attribute BOUNDARY\_CELLS of S3C4510B : entity is "BC\_4, BC\_2, BC\_1";

attribute BOUNDARY\_LENGTH of S3C4510B : entity is 233;

attribute BOUNDARY\_REGISTER of S3C4510B : entity is

```
-- num  cell port      function safe [ccell disval rslt]
```

```
"0 ( BC_2, UARXD1,      input,  X) ," &
"1 ( BC_1, nUADSR0,    output2, X) ," &
"2 ( BC_1, UATXD0,     output2, X) ," &
"3 ( BC_2, nUADTR0,    input,  X) ," &
```

```

"4 ( BC_2, UARXD0,      input,  X) ," &
"5 ( BC_1, SDA,        output3, 1, 5, 1, Z) ," & -- Open-drain Output

"6 ( BC_2, SDA,        input,  X) ," &
"7 ( BC_1, SCL,        output3, 1, 7, 1, Z) ," & -- Open-drain Output
"8 ( BC_2, SCL,        input,  X) ," &

"9 ( BC_1, *,          controlr, 1) ," & --P_ENB(17)
"10 ( BC_1, P(17),     output3, X, 9, 1, Z) ," &
"11 ( BC_2, P(17),     input,  X) ," &

"12 ( BC_1, *,         controlr, 1) ," & --P_ENB(16)
"13 ( BC_1, P(16),     output3, X, 12, 1, Z) ," &
"14 ( BC_2, P(16),     input,  X) ," &

"15 ( BC_1, *,         controlr, 1) ," & --P_ENB(15)
"16 ( BC_1, P(15),     output3, X, 15, 1, Z) ," &
"17 ( BC_2, P(15),     input,  X) ," &

"18 ( BC_1, *,         controlr, 1) ," & --P_ENB(14)
"19 ( BC_1, P(14),     output3, X, 18, 1, Z) ," &
"20 ( BC_2, P(14),     input,  X) ," &

"21 ( BC_1, *,         controlr, 1) ," & --P_ENB(13)
"22 ( BC_1, P(13),     output3, X, 21, 1, Z) ," &
"23 ( BC_2, P(13),     input,  X) ," &

"24 ( BC_1, *,         controlr, 1) ," & --P_ENB(12)
"25 ( BC_1, P(12),     output3, X, 24, 1, Z) ," &
"26 ( BC_2, P(12),     input,  X) ," &

"27 ( BC_1, *,         controlr, 1) ," & --P_ENB(11)
"28 ( BC_1, P(11),     output3, X, 27, 1, Z) ," &
"29 ( BC_2, P(11),     input,  X) ," &

"30 ( BC_1, *,         controlr, 1) ," & --P_ENB(10)
"31 ( BC_1, P(10),     output3, X, 30, 1, Z) ," &
"32 ( BC_2, P(10),     input,  X) ," &
"33 ( BC_1, *,         controlr, 1) ," & --P_ENB(9)
"34 ( BC_1, P(9),      output3, X, 33, 1, Z) ," &
"35 ( BC_2, P(9),      input,  X) ," &

"36 ( BC_1, *,         controlr, 1) ," & --P_ENB(8)
"37 ( BC_1, P(8),      output3, X, 36, 1, Z) ," &
"38 ( BC_2, P(8),      input,  X) ," &

"39 ( BC_1, *,         controlr, 1) ," & --P_ENB(7)
"40 ( BC_1, P(7),      output3, X, 39, 1, Z) ," &
"41 ( BC_2, P(7),      input,  X) ," &

```

```

"42 ( BC_1, *,          controlr, 1) ," & --P_ENB(6)
"43 ( BC_1, P(6),      output3, X,  42, 1, Z) ," &
"44 ( BC_2, P(6),      input,  X) ," &

"45 ( BC_1, *,          controlr, 1) ," & --P_ENB(5)
"46 ( BC_1, P(5),      output3, X,  45, 1, Z) ," &
"47 ( BC_2, P(5),      input,  X) ," &

"48 ( BC_1, *,          controlr, 1) ," & --P_ENB(4)
"49 ( BC_1, P(4),      output3, X,  48, 1, Z) ," &
"50 ( BC_2, P(4),      input,  X) ," &

"51 ( BC_1, *,          controlr, 1) ," & --P_ENB(3)
"52 ( BC_1, P(3),      output3, X,  51, 1, Z) ," &
"53 ( BC_2, P(3),      input,  X) ," &

"54 ( BC_1, *,          controlr, 1) ," & --P_ENB(2)
"55 ( BC_1, P(2),      output3, X,  54, 1, Z) ," &
"56 ( BC_2, P(2),      input,  X) ," &

"57 ( BC_1, *,          controlr, 1) ," & --P_ENB(1)
"58 ( BC_1, P(1),      output3, X,  57, 1, Z) ," &
"59 ( BC_2, P(1),      input,  X) ," &

"60 ( BC_1, *,          controlr, 1) ," & --P_ENB(0)
"61 ( BC_1, P(0),      output3, X,  60, 1, Z) ," &
"62 ( BC_2, P(0),      input,  X) ," &

"63 ( BC_1, XDATA(31), output3, X, 127, 1, Z) ," &
"64 ( BC_2, XDATA(31), input,  X) ," &

"65 ( BC_1, XDATA(30), output3, X, 127, 1, Z) ," &
"66 ( BC_2, XDATA(30), input,  X) ," &

"67 ( BC_1, XDATA(29), output3, X, 127, 1, Z) ," &
"68 ( BC_2, XDATA(29), input,  X) ," &

"69 ( BC_1, XDATA(28), output3, X, 127, 1, Z) ," &
"70 ( BC_2, XDATA(28), input,  X) ," &

"71 ( BC_1, XDATA(27), output3, X, 127, 1, Z) ," &
"72 ( BC_2, XDATA(27), input,  X) ," &

"73 ( BC_1, XDATA(26), output3, X, 127, 1, Z) ," &
"74 ( BC_2, XDATA(26), input,  X) ," &

"75 ( BC_1, XDATA(25), output3, X, 127, 1, Z) ," &
"76 ( BC_2, XDATA(25), input,  X) ," &

```



---

"77 ( BC_1, XDATA(24), "78 ( BC_2, XDATA(24),	output3, X, 127, 1, Z) ," & input, X) ," &
"79 ( BC_1, XDATA(23), "80 ( BC_2, XDATA(23),	output3, X, 127, 1, Z) ," & input, X) ," &
"81 ( BC_1, XDATA(22), "82 ( BC_2, XDATA(22),	output3, X, 127, 1, Z) ," & input, X) ," &
"83 ( BC_1, XDATA(21), "84 ( BC_2, XDATA(21),	output3, X, 127, 1, Z) ," & input, X) ," &
"85 ( BC_1, XDATA(20), "86 ( BC_2, XDATA(20),	output3, X, 127, 1, Z) ," & input, X) ," &
"87 ( BC_1, XDATA(19), "88 ( BC_2, XDATA(19),	output3, X, 127, 1, Z) ," & input, X) ," &
"89 ( BC_1, XDATA(18), "90 ( BC_2, XDATA(18),	output3, X, 127, 1, Z) ," & input, X) ," &
"91 ( BC_1, XDATA(17), "92 ( BC_2, XDATA(17),	output3, X, 127, 1, Z) ," & input, X) ," &
"93 ( BC_1, XDATA(16), "94 ( BC_2, XDATA(16),	output3, X, 127, 1, Z) ," & input, X) ," &
"95 ( BC_1, XDATA(15), "96 ( BC_2, XDATA(15),	output3, X, 127, 1, Z) ," & input, X) ," &
"97 ( BC_1, XDATA(14), "98 ( BC_2, XDATA(14),	output3, X, 127, 1, Z) ," & input, X) ," &
"99 ( BC_1, XDATA(13), "100 ( BC_2, XDATA(13),	output3, X, 127, 1, Z) ," & input, X) ," &
"101 ( BC_1, XDATA(12), "102 ( BC_2, XDATA(12),	output3, X, 127, 1, Z) ," & input, X) ," &
"103 ( BC_1, XDATA(11), "104 ( BC_2, XDATA(11),	output3, X, 127, 1, Z) ," & input, X) ," &
"105 ( BC_1, XDATA(10), "106 ( BC_2, XDATA(10),	output3, X, 127, 1, Z) ," & input, X) ," &
"107 ( BC_1, XDATA(9), "108 ( BC_2, XDATA(9),	output3, X, 127, 1, Z) ," & input, X) ," &
"109 ( BC_1, XDATA(8),	output3, X, 127, 1, Z) ," &

---

```

"110 ( BC_2, XDATA(8),      input,  X) ," &

"111 ( BC_1, XDATA(7),      output3, X, 127, 1, Z) ," &
"112 ( BC_2, XDATA(7),      input,  X) ," &

"113 ( BC_1, XDATA(6),      output3, X, 127, 1, Z) ," &
"114 ( BC_2, XDATA(6),      input,  X) ," &

"115 ( BC_1, XDATA(5),      output3, X, 127, 1, Z) ," &
"116 ( BC_2, XDATA(5),      input,  X) ," &

"117 ( BC_1, XDATA(4),      output3, X, 127, 1, Z) ," &
"118 ( BC_2, XDATA(4),      input,  X) ," &

"119 ( BC_1, XDATA(3),      output3, X, 127, 1, Z) ," &
"120 ( BC_2, XDATA(3),      input,  X) ," &

"121 ( BC_1, XDATA(2),      output3, X, 127, 1, Z) ," &
"122 ( BC_2, XDATA(2),      input,  X) ," &

"123 ( BC_1, XDATA(1),      output3, X, 127, 1, Z) ," &
"124 ( BC_2, XDATA(1),      input,  X) ," &

"125 ( BC_1, XDATA(0),      output3, X, 127, 1, Z) ," &
"126 ( BC_2, XDATA(0),      input,  X) ," &

"127 ( BC_1, *,             controlr, 1) ," & --DATAOUT_ENB

"128 ( BC_1, ADDR(21),       output3, X, 184, 1, Z) ," &
"129 ( BC_1, ADDR(20),       output3, X, 184, 1, Z) ," &
"130 ( BC_1, ADDR(19),       output3, X, 184, 1, Z) ," &
"131 ( BC_1, ADDR(18),       output3, X, 184, 1, Z) ," &
"132 ( BC_1, ADDR(17),       output3, X, 184, 1, Z) ," &
"133 ( BC_1, ADDR(16),       output3, X, 184, 1, Z) ," &
"134 ( BC_1, ADDR(15),       output3, X, 184, 1, Z) ," &
"135 ( BC_1, ADDR(14),       output3, X, 184, 1, Z) ," &
"136 ( BC_1, ADDR(13),       output3, X, 184, 1, Z) ," &
"137 ( BC_1, ADDR(12),       output3, X, 184, 1, Z) ," &
"138 ( BC_1, ADDR(11),       output3, X, 184, 1, Z) ," &
"139 ( BC_1, ADDR(10),       output3, X, 184, 1, Z) ," &
"140 ( BC_1, ADDR(9),        output3, X, 184, 1, Z) ," &
"141 ( BC_1, ADDR(8),        output3, X, 184, 1, Z) ," &
"142 ( BC_1, ADDR(7),        output3, X, 184, 1, Z) ," &
"143 ( BC_1, ADDR(6),        output3, X, 184, 1, Z) ," &
"144 ( BC_1, ADDR(5),        output3, X, 184, 1, Z) ," &
"145 ( BC_1, ADDR(4),        output3, X, 184, 1, Z) ," &
"146 ( BC_1, ADDR(3),        output3, X, 184, 1, Z) ," &
"147 ( BC_1, ADDR(2),        output3, X, 184, 1, Z) ," &
"148 ( BC_1, ADDR(1),        output3, X, 184, 1, Z) ," &
"149 ( BC_1, ADDR(0),        output3, X, 184, 1, Z) ," &

```

```

"150 ( BC_1, ExtMACK,      output2, X) ," &
"151 ( BC_2, ExtMREQ,     input,  X) ," &

"152 ( BC_1, nWBE(3),     output3, X,  184, 1, Z) ," &
"153 ( BC_1, nWBE(2),     output3, X,  184, 1, Z) ," &
"154 ( BC_1, nWBE(1),     output3, X,  184, 1, Z) ," &
"155 ( BC_1, nWBE(0),     output3, X,  184, 1, Z) ," &

"156 ( BC_1, nDWE,        output3, X,  184, 1, Z) ," &

"157 ( BC_1, nCAS(3),     output3, X,  184, 1, Z) ," &
"158 ( BC_1, nCAS(2),     output3, X,  184, 1, Z) ," &
"159 ( BC_1, nCAS(1),     output3, X,  184, 1, Z) ," &
"160 ( BC_1, nCAS(0),     output3, X,  184, 1, Z) ," &

"161 ( BC_1, nRAS(3),     output3, X,  184, 1, Z) ," &
"162 ( BC_1, nRAS(2),     output3, X,  184, 1, Z) ," &
"163 ( BC_1, nRAS(1),     output3, X,  184, 1, Z) ," &
"164 ( BC_1, nRAS(0),     output3, X,  184, 1, Z) ," &

"165 ( BC_1, nRCS(5),     output3, X,  184, 1, Z) ," &
"166 ( BC_1, nRCS(4),     output3, X,  184, 1, Z) ," &
"167 ( BC_1, nRCS(3),     output3, X,  184, 1, Z) ," &
"168 ( BC_1, nRCS(2),     output3, X,  184, 1, Z) ," &
"169 ( BC_1, nRCS(1),     output3, X,  184, 1, Z) ," &

"170 ( BC_2, CLKSEL,      input,  X) ," &
"171 ( BC_2, nRESET,      input,  X) ," &
"172 ( BC_4, MCLK,         input,  X) ," &
"173 ( BC_1, MCLKO,        output2, X) ," &
"174 ( BC_2, CLKOEN,       input,  X) ," &

"175 ( BC_1, nRCS(0),     output3, X,  184, 1, Z) ," &

"176 ( BC_2, B0SIZE(1),    input,  X) ," &
"177 ( BC_2, B0SIZE(0),    input,  X) ," &

"178 ( BC_1, nOE,         output3, X,  184, 1, Z) ," &

"179 ( BC_2, nEWAIT,       input,  X) ," &

"180 ( BC_1, nECS(3),     output3, X,  184, 1, Z) ," &
"181 ( BC_1, nECS(2),     output3, X,  184, 1, Z) ," &
"182 ( BC_1, nECS(1),     output3, X,  184, 1, Z) ," &
"183 ( BC_1, nECS(0),     output3, X,  184, 1, Z) ," &

```

```

"184 ( BC_1, *,          controlr, 1) ," & --DIS_BUS

"185 ( BC_2, UCLK,      input, X) ," &
"186 ( BC_2, TMODE,    input, X) ," &

"187 ( BC_1, MDC,      output2, X) ," &
"188 ( BC_2, LITTLE,  input, X) ," &

"189 ( BC_1, *,          controlr, 1) ," & --MDIO_OE
"190 ( BC_1, MDIO,      output3, X, 189, 1, Z) ," &
"191 ( BC_2, MDIO,      input, X) ," &

"192 ( BC_1, TX_EN_TXEN_10M, output2, X) ," &
"193 ( BC_2, TX_CLK_TXCLK_10M, input, X) ," &
"194 ( BC_1, TX_ERR_PCOMP_10M, output2, X) ," &
"195 ( BC_1, TXD3,      output2, X) ," &
"196 ( BC_1, TXD2,      output2, X) ," &
"197 ( BC_1, TXD1_LOOP10, output2, X) ," &
"198 ( BC_1, TXD0_TXD_10M, output2, X) ," &
"199 ( BC_2, COL_COL_10M, input, X) ," &
"200 ( BC_2, RX_CLK_RXCLK_10M, input, X) ," &
"201 ( BC_2, RX_ERR,    input, X) ," &
"202 ( BC_2, RXD3,      input, X) ," &
"203 ( BC_2, RXD2,      input, X) ," &
"204 ( BC_2, RXD1,      input, X) ," &
"205 ( BC_2, RXD0_RXD_10M, input, X) ," &
"206 ( BC_2, RX_DV_LINK10, input, X) ," &
"207 ( BC_2, CRS_CRS_10M, input, X) ," &

"208 ( BC_1, *,          controlr, 1) ," & --TXCBEN
"209 ( BC_1, TXCB,      output3, X, 208, 1, Z) ," &
"210 ( BC_2, TXCB,      input, X) ," &

"211 ( BC_1, nSYNCB,    output2, X) ," &
"212 ( BC_2, RXCB,      input, X) ," &
"213 ( BC_2, nDCDB,     input, X) ," &
"214 ( BC_2, nCTSB,     input, X) ," &
"215 ( BC_1, TXDB,      output2, X) ," &
"216 ( BC_1, nRTSB,     output2, X) ," &
"217 ( BC_2, RXDB,      input, X) ," &
"218 ( BC_1, nDTRB,     output2, X) ," &

"219 ( BC_1, *,          controlr, 1) ," & --TXCAEN
"220 ( BC_1, TXCA,      output3, X, 219, 1, Z) ," &
"221 ( BC_2, TXCA,      input, X) ," &

```

```
"222 ( BC_1, nSYNCA,      output2, X) ," &  
"223 ( BC_2, RXCA,       input,  X) ," &  
"224 ( BC_2, nDCDA,      input,  X) ," &  
"225 ( BC_2, nCTSA,      input,  X) ," &  
"226 ( BC_1, TXDA,       output2, X) ," &  
"227 ( BC_1, nRTSA,      output2, X) ," &  
"228 ( BC_2, RXDA,       input,  X) ," &  
"229 ( BC_1, nDTRA,      output2, X) ," &  
"230 ( BC_1, nUADSR1,    output2, X) ," &  
"231 ( BC_1, UATXD1,     output2, X) ," &  
"232 ( BC_2, nUADTR1,    input,  X) " ;  
end S3C4510B;
```

## NOTES