

**INTRODUCTION**

The KS8620 consists of on-chip PCM encoders, decoders (PCM CODECs) and PCM line filter. This device provide all the functions required to interface a full-duplex voice telephone circuit, digital answering phone. This device is designed to perform the transmit encoding and receive decoding as well as the transmit and receive filtering function in PCM system. Also it is intended to be used at the analog termination of a PCM line / trunk. This device provide the Band pass filtering of the analog signals prior to encoding and after decoding. This combination device performs the encoding and decoding of voice and call progress tones as well as the signaling and supervision information.

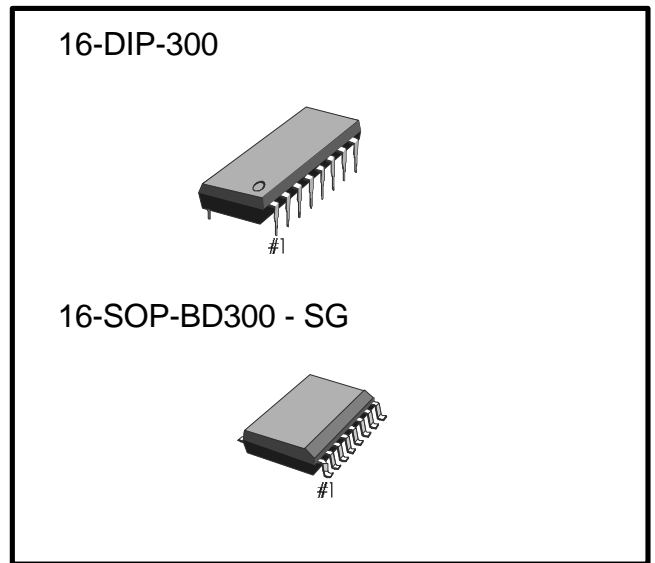

**ORDERING INFORMATION**

Device	Package	Operating Temperature
KS8620N	16-DIP-300	0°C ~ + 70°C
KS8620D	16-SOP- BD300 - SG	

**FEATURES**

- Complete CODEC and filtering system
- Encoding / Decoding : 8 bits  $\mu$ -law PCM
- On-chip auto zero, sample and hold, and precision voltage references
- Low power dissipation : 60mW ( operating )  
3mW ( standby )
- $\pm 5V$  operation
- TTL or CMOS compatible
- Automatic power down

**PIN CONFIGURATION**

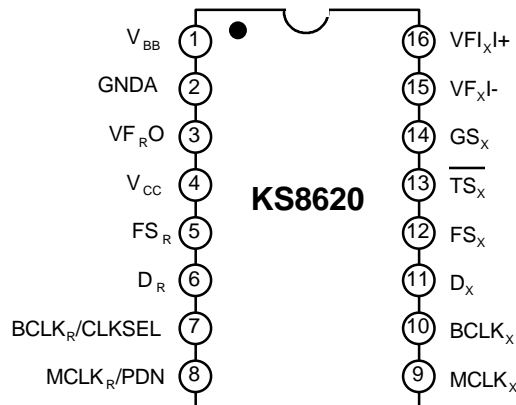

BLOCK DIAGRAM

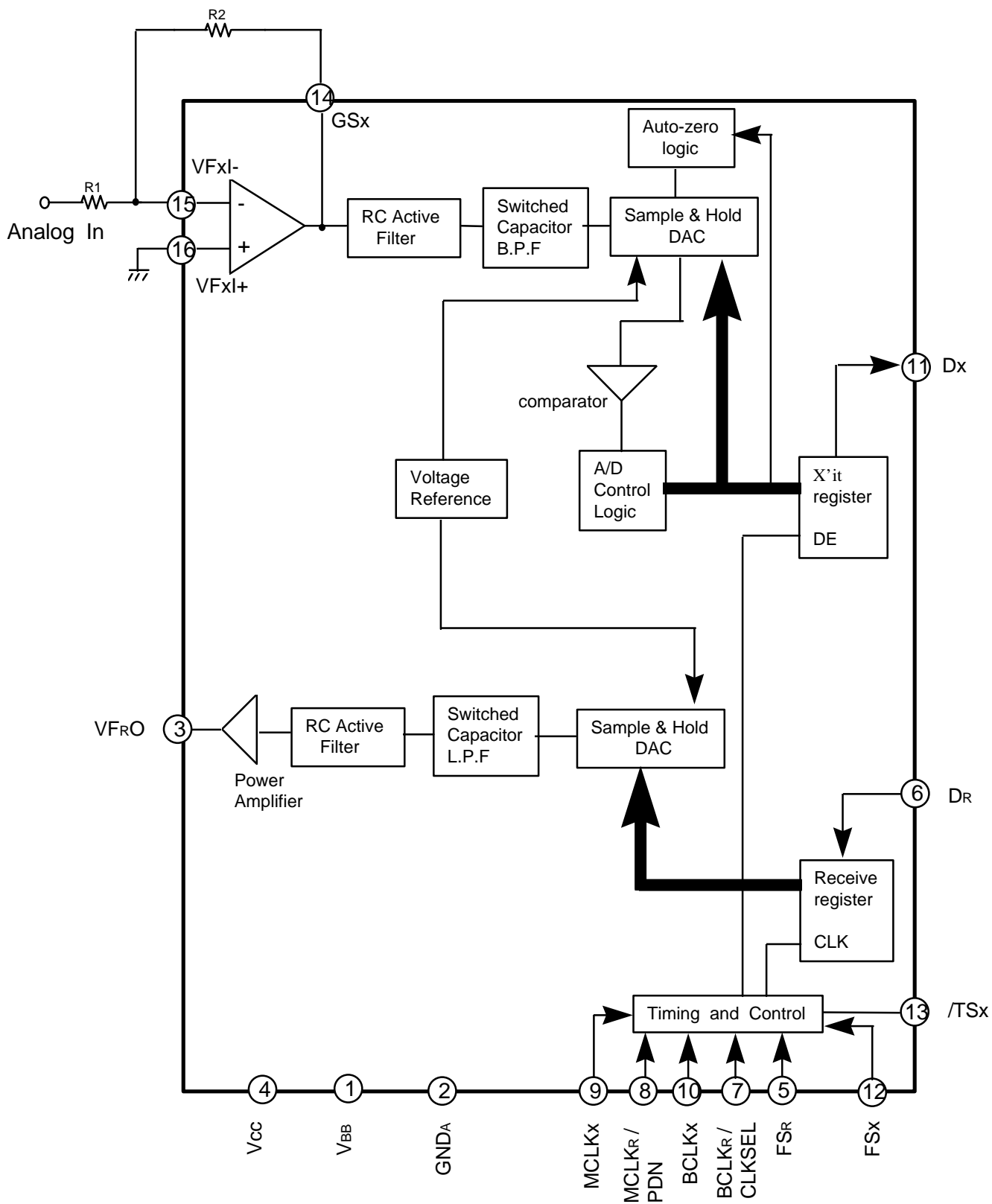

Fig 1. Block Diagram

## PIN DESCRIPTION

Pin No	Symbol	Description
1	V <sub>BB</sub>	V <sub>BB</sub> = -5V ± 5%
2	GND <sub>A</sub>	Analog ground
3	VF <sub>R</sub> O	Analog output of the receiver filter
4	V <sub>CC</sub>	V <sub>CC</sub> = +5V ± 5%
5	FS <sub>R</sub>	Receive frame sync pulse. 8KHz pulse train.
6	D <sub>R</sub>	PCM data input
7	BCLK <sub>R</sub> / CLKSEL	Logic input which selects either 1.536MHz / 1.544MHz or 2.048MHz for master clock in normal operation and BCLK <sub>x</sub> is used for both TX and RX directions. Alternately direct clock input available, vary from 64KHz to 2.048MHz.
8	MCLK <sub>R</sub> / PDN	When MCLK <sub>R</sub> is connected continuously high, the device goes powered down. Normally connected continuously low, MCLK <sub>x</sub> is selected for all DAC timing. Alternately direct 1.536MHz / 1.544MHz or 2.048MHz clock input is available.
9	MCLK <sub>X</sub>	1.536MHz / 1.544MHz or 2.048MHz clock input is available
10	BCLK <sub>X</sub>	May be vary from 64KHz 2.048MHz, but BCLK <sub>x</sub> is externally tied with MCLK <sub>x</sub> in normal operation.
11	D <sub>X</sub>	PCM data output.
12	FS <sub>X</sub>	TX frame sync pulse. 8KHz pulse train.
13	TS <sub>X</sub>	Changed from high to low during the encoder timeslot. Open drain output.
14	GS <sub>X</sub>	Analog output of the TX input amplifier. Used to set gain through external resistor between pin 14 to pin 15.
15	VF <sub>X</sub> I-	Inverting input stage of the TX analog signal.
16	VF <sub>X</sub> I+	Non-inverting input stage of the TX analog signal.

## ABSOLUTE MAXIMUM RATINGS ( Ta = 25 °C)

Characteristic	Symbol	Value	Unit
Positive Supply Voltage	V <sub>CC</sub>	+7	V
Negative Supply Voltage	V <sub>BB</sub>	-7	V
Voltage at any Analog Input or Output	V <sub>I(A)</sub>	V <sub>CC</sub> + 0.3 to V <sub>BB</sub> - 0.3	V
Voltage at any Digital Input or Output	V <sub>I(D)</sub>	V <sub>CC</sub> + 0.3 to GND <sub>A</sub> - 0.3	V
Operating Temperature Range	T <sub>a</sub>	0 to 70	°C
Storage Temperature Range	T <sub>STG</sub>	-65 to +150	°C
Lead Temperature Range ( soldering , 10 sec )	T <sub>LEAD</sub>	300	°C

**ELECTRICAL CHARACTERISTICS**(Unless otherwise specified :  $T_a = 0^{\circ}\text{C}$  to  $70^{\circ}\text{C}$  ,  $V_{CC} = 5\text{V} \pm 5\%$ ,  $V_{BB} = -5\text{V} \pm 5\%$ ,  $GND_A = 0\text{V}$  )

Characteristic	System	Test Conditions	Min	Typ	Max	Unit
Power Dissipation						
Power down Current	$I_{CC}(\text{down})$	No Load		0.5	3.0	mA
	$I_{BB}(\text{down})$	No Load		0.05	1.0	
Active Current	$I_{CC}(A)$	No Load		6.0	10	mA
	$I_{BB}(A)$	No Load		6.0	10	
Digital Interface						
Input Low Voltage	$V_{IL}$				0.6	V
Input High Voltage	$V_{IH}$		2.2			V
Input Low Current	$I_{IL}$	$GND_A < V_{IN} < V_{IL}$ , all digital input	-15		15	$\mu\text{A}$
Input High Current	$I_{IH}$	$V_{IH} < V_{IN} < V_{CC}$	-15		15	$\mu\text{A}$
Output Low Voltage	$V_{OL}$	$D_x$ , $I_L = 3.2\text{mA}$			0.4	V
		$SIG_R$ , $I_L = 1.0\text{mA}$			0.4	
		$/TS_x$ , $I_L = 3.2\text{mA}$ , open drain			0.4	
Output High Voltage	$V_{OH}$	$D_x$ , $I_H = -3.2\text{mA}$	2.4			V
		$SIG_R$ , $I_H = -1.0\text{mA}$	2.4			
Output Current in High impedance state ( Tri - state )	$I_{OH(HZ)}$	$D_x$ , $GND_A < V_o < V_{CC}$	-15		15	$\mu\text{A}$
Analog Interface with Receiver Filter						
Output Resistance	$R_o$	pin $V_{FRO}$		1	3	$\Omega$
Load Resistance	$R_L$	$V_{FRO} = + / - 2.5\text{V}$	600			$\Omega$
Load Capacitance	$C_L$				500	pF
Output DC offset voltage	$V_{OO(RX)}$		-200		200	mV
Analog Interface with Transmit input Amp						
Input Leakage Current	$I_{LKG}$	$-2.5\text{V} < V < +2.5\text{V}$ , $V_{FXL+}$ or $V_{FXL-}$	-200		200	nA
Input Resistance	$R_I$	$-2.5\text{V} < V < +2.5\text{V}$ , $V_{FXL+}$ or $V_{FXL-}$	10			$\text{M}\Omega$
Output Resistance	$R_o$	closed loop , unity gain		1	3	$\Omega$
Load Resistance	$R_L$	$GS_x$	10			$\text{K}\Omega$
Load Capacitance	$C_L$	$GS_x$			50	pF
Output Dynamic Range	$V_{OD(TX)}$	$GS_x$ , $R_L < 10\text{K}\Omega$	+/-2.8			V
Voltage Gain	$G_v$	$V_{FXL+}$ to $GS_x$	5,000			V / V
Unity Gain bandwidth	$BW$		1	2		MHz
Offset Voltage	$V_{IO(TX)}$		-20		20	mV
Common - mode Voltage	$V_{CM(TX)}$	$CMRR_xA > 60\text{dB}$	-2.5		2.5	V
Common mode rejection ratio	CMRR	DC test	55			dB
Power supply rejection ratio	PSRR	DC test	55			dB

**TIMING CHARACTERISTICS**(Unless otherwise specified : Ta = 0°C to 70°C, Vcc = 5V ±5%, VBB = -5V ±5%, GND<sub>A</sub> = 0V )

Characteristic	System	Test Conditions	Min	Typ	Max	Unit
Frequency of Master Clock	f <sub>MCK</sub>	Depends on the device used and the BCLK <sub>R</sub> /CLKSEL pin. MCLK <sub>x</sub> and MCLK <sub>R</sub>		1.536		MHz
				1.544		
				2.048		
Rise time of Bit Clock	t <sub>r(BCK)</sub>	t <sub>PB</sub> = 488ns			50	nS
Fall Time of Bit Clock	t <sub>f(BCK)</sub>	t <sub>PB</sub> = 488ns			50	nS
Hold Time for Bit Clock low to Frame sync	t <sub>H(LFS)</sub>	Long Frame only	0			nS
Hold Time for Bit Clock High to Frame sync	t <sub>H(HFS)</sub>	Short Frame only	0			nS
Set-up Time from Frame sync to Bit Clock low	t <sub>SU(FBCL)</sub>	Long Frame only	80			nS
Delay time from BCLK <sub>x</sub> High to data valid	t <sub>D(HDV)</sub>	Load = 150pF + 2 LSTTL loads	0		180	nS
Delay time to /TS <sub>x</sub> low	t <sub>D(TSXL)</sub>	Load = 150pF + 2 LSTTL loads			140	nS
Delay time from BCLK <sub>x</sub> low to data output disable	t <sub>D(LDD)</sub>		50		165	nS
Delay Time to valid data from FS <sub>x</sub> or BCLK <sub>x</sub> .	t <sub>D(VD)</sub>	CL = 0 pF to 150 pF Whichever comes later.	20		165	nS
Set-up Time from DR valid to BCLK <sub>x/R</sub> low	t <sub>SU(DRBL)</sub>		50			nS
Hold time from BCLK <sub>x/R</sub> low to DR invalid	t <sub>H(BLDR)</sub>		50			nS
Set-up time from FS <sub>x/R</sub> to BCLK <sub>x/R</sub> low	t <sub>SU(FBLS)</sub>	Short Frame sync pulse ( 1 or 2 bit clock periods long ) : note1	50			nS
Width of master clock High	t <sub>W(MCKH)</sub>	MCLK <sub>x</sub> and MCLK <sub>R</sub>	160			nS
Width of master clock Low	t <sub>W(MCKL)</sub>	MCLK <sub>x</sub> and MCLK <sub>R</sub>	160			nS
Rise Time of Master clock	t <sub>r(MCK)</sub>	MCLK <sub>x</sub> and MCLK <sub>R</sub>			50	nS
Fall Time of Master clock	t <sub>f(MCK)</sub>	MCLK <sub>x</sub> and MCLK <sub>R</sub>			50	nS
Set-up time from BCLK <sub>x</sub> High ( FS <sub>x</sub> in Long Frame Sync mode ) to MCLK <sub>x</sub> falling edge	t <sub>SU(BHMF)</sub>	1`st bit clock after the leading edge of FS <sub>x</sub>	50			nS
Period of Bit Clock	t <sub>CK</sub>		485	488	15,725	nS
Width of Bit clock High	t <sub>W(BCKH)</sub>	V <sub>IH</sub> = 2.2V	160			nS
Width of Bit clock Low	t <sub>W(BCKL)</sub>	V <sub>IL</sub> = 0.6V	160			nS
Hold time from BCLK <sub>x/R</sub> to FS <sub>x/R</sub> low	t <sub>H(BLFL)</sub>	Short Frame sync pulse ( 1 or 2 bit clock periods long ) : note1	100			nS

**TRANSMISSION CHARACTERISTICS**

(Unless otherwise specified : Ta = 0°C to 70°C, Vcc = 5V ±5%, VBB = -5V ±5%, GND<sub>A</sub> = 0V, f = 1.02KHz  
Vin = 0dBm0, transmit input amplifier connected for unity-gain, non-inverting )

Characteristic	System	Test Conditions	Min	Typ	Max	Unit
Amplitude Response						
Receive Gain, Absolute	$G_{V(ARX)}$	Ta=25°C, Vcc = 5V, VBB = -5V Input = Digital code sequence for 0dBm0 signal at 1020Hz	-1.5		1.5	dB
Receive Gain, Relative to $G_{V(RRX)}$	$G_{V(RRX)}$	f = 0Hz to 3000Hz f = 3300Hz f = 3400Hz f = 4000Hz	-0.6 -0.55 -1.5		0.5 0.5 1.5	dB
Absolute Receive Gain Variations with temperature	$\Delta G_{V(ARX)} / \Delta T$	Ta = 0°C to 70°C			± 0.1	dB
Receive Gain Variations with level	$\Delta G_{V(RXL)}$	Sinusoidal test method; reference input PCM code correspond to an ideally encoded -10dBm0 signal PCM level = -40dBm0 to +3dBm0 PCM level = -50dBm0 to -40dBm0	-0.4 -0.8		0.4 0.8	dB
Receive output drive level		R <sub>L</sub> = 600Ω	-2.5		2.5	V
Absolute level	$V_{O(RX)}$ $V_{AL}$	Norminal 0dBm0 level is same as 4 dBm ( 600Ω )		1.2276		Vrms
Max overload level	$V_{OL(MAX)}$	Max overload level ( 3.17dBm0)		2.501		V <sub>PK</sub>
Transmit gain, absolute	$G_{V(ATX)}$	Ta = 25°C, Vcc = 5V, VBB = -5V Input at GSx = 0dBm0 at 1020Hz	-1.5		1.5	dB
Transmit gain, relative to $G_{V(ATX)}$	$G_{V(RTX)}$	f = 16 Hz f = 50 Hz f = 60 Hz f = 200 Hz f = 300 Hz - 3000Hz f = 3300 Hz f = 3400 Hz f = 4000 Hz f = 4600 Hz and above, mesaure response from 0 Hz to 4 KHz			-35 -25 -21 -0.5 0.5 0.5 -1.5 -1.5 -25	dB

## TRANSMISSION CHARACTERISTICS ( Continued )

Characteristic	System	Test Conditions	Min	Typ	Max	Unit
Absolute transmit gain variations with temperature	$\Delta G_{V(ATX)} / \Delta T$	Ta = 0°C to 70°C			± 0.1	dB
Transmit gain variations with level	$\Delta G_{V(TXL)}$	Sinusoidal test method ; Reference level = -10dBm0 VF <sub>X</sub> ! + = -40dBm0 to +3dB0 VF <sub>X</sub> ! + = -50dBm0 to -40dB0	-0.4 -0.8		0.4 0.8	dB
Envelope Delay Distortion with Frequency						
Receive Delay, Absolute	t <sub>D(ARX)</sub>	f = 1600Hz			200	µs
Receive Delay, Relative to t <sub>D(ARX)</sub>	t <sub>D(RRX)</sub>	f = 500Hz - 1000Hz f = 1000Hz - 1600Hz f = 1600Hz - 2600Hz f = 2600Hz - 2800Hz f = 2800Hz - 3000Hz	-40 -30		90 125 175	µs
Transmit Delay, Absolute	t <sub>D(ATX)</sub>	f = 1600Hz			315	µs
Transmit Delay, Relative to t <sub>D(ATX)</sub>	t <sub>D(RTX)</sub>	f = 500Hz - 600Hz f = 600Hz - 800Hz f = 800Hz - 1000Hz f = 1000Hz - 1600Hz f = 1600Hz - 2600Hz f = 2600Hz - 2800Hz f = 2800Hz - 3000Hz			220 145 75 40 75 105 155	µs
Noise						
Receive Noise, C Message Weighted	N <sub>RXC</sub>	PCM code equals alternating positive and negative zero, KS8620			18	dBrnC0
Transmit Noise, C Message Weighted	N <sub>TXC</sub>	KS8620			15	dBrnC0

## TRANSMISSION CHARACTERISTICS ( Continued )

Characteristic	System	Test Conditions	Min	Typ	Max	Unit
Noise, Single Frequency	NSF	f = 0KHz to 100KHz, loop around measurement, $V_{Fxl+} = 0V_{rms}$			-53	dBm0
Positive Power Supply Rejection, Transmit	$PSRR_{(PTX)}$	$V_{Fxl+} = 0 V_{rms}$ , $V_{CC} = 5.0 V_{DC} + 100mV_{ms}$ f = 0KHz - 50KHz	25			dB
Negative Power Supply Rejection, Transmit	$PSRR_{(NTX)}$	$V_{Fxl+} = 0 V_{rms}$ , $V_{BB} = -5.0 V_{DC} + 100mV_{rms}$ f = 0KHz - 50KHz	25			dB
Positive Power Supply Rejection, Receive	$PSRR_{(PRX)}$	PCM code equals positive zero $V_{CC} = 5.0V_{DC} + 100mV_{rms}$ f = 0Hz - 4000Hz f = 4KHz - 25KHz	25 25			dB dB
Negative Power Supply Rejection, Receive	$PSRR_{(NRX)}$	PCM code equals positive zero $V_{BB} = -5.0V_{DC} + 100mV_{rms}$ f = 0Hz - 4000Hz f = 4KHz - 25KHz	25 25			dB dB
Spurious Out-Band Signals at the Channel Output	SOS	Loop around measurement, 0dBm0, 300Hz - 3400Hz input PCM applied to $D_R$ , Measure individual image signals at $V_{FR0}$ 4600Hz - 7600Hz 7600Hz - 100,000Hz			-28 -35	dB
Distortion						
Signal to Total Distortion Transmit or Receive Half-Channel	$THD_{TX}$ $THD_{RX}$	Sinusoidal test method ; level = 3.0dBm0 = 0dBm0 to 30dBm0 = -40dBm0 XMT RCV	28 30 25 25			dB



**TRANSMISSION CHARACTERISTICS ( Continued )**

Characteristic	System	Test Conditions	Min	Typ	Max	Unit
Single Frequency Disotrtion, Transmit	THD <sub>SF(TX)</sub>				-41	-dB
Single Frequency Distortion, Receive	THD <sub>SF(RX)</sub>				-41	-dB
Intermodulation Distortion	THD <sub>IMD</sub>	Loop around measurement, VF <sub>XI+</sub> = -4dBm0 to -21dBm0, two frequencies in the range 300Hz - 3400Hz			-35	-dB
Crosstalk						
Transmit to Receive Crosstalk, 0dBm0 Transmit level	CT <sub>(TX-RX)</sub>	f = 300Hz - 3400Hz D <sub>R</sub> = Steady PCM code		-90	-75	dB
Reveive to Transmit Crosstalk, 0dBm0 Receive level	CT <sub>(RX-TX)</sub>	f = 300Hz - 3400Hz, VFXI = 0V		-90	-70 (note1)	dB

Note 1. CT<sub>(RX-TX)</sub> is measured with a -40dBm0 activating signal applied at VF<sub>XI+</sub>

**ENCODING FORMAT AT D<sub>X</sub> OUTPUT**

	$\mu$ -Law PCM : KS8620
V <sub>IN</sub> ( at GS <sub>X</sub> ) = + Full Scale	1 0 0 0 0 0 0 0
V <sub>IN</sub> ( at GS <sub>X</sub> ) = 0V	1 1 1 1 1 1 1 1 0 1 1 1 1 1 1 1
V <sub>IN</sub> ( at GS <sub>X</sub> ) = - Full Scale	0 0 0 0 0 0 0 0