

8M x 8bit CMOS Dynamic RAM with Extended Data Out

DESCRIPTION

This is a family of 8,388,608 x 8 bit Extended Data Out Mode CMOS DRAMs. Extended Data Out Mode offers high speed random access of memory cells within the same row. Refresh cycle(4K Ref. or 8K Ref.), access time (-45, -5 or -6), package type (SOJ or TSOP-II) are optional features of this family. All of this family have $\overline{\text{CAS}}$ -before- $\overline{\text{RAS}}$ refresh, $\overline{\text{RAS}}$ -only refresh and Hidden refresh capabilities. This 8Mx8 EDO Mode DRAM family is fabricated using Samsung's advanced CMOS process to realize high band-width, low power consumption and high reliability.

FEATURES

• **Part Identification**

- KM48C8004B(5.0V, 8K Ref.)
- KM48C8104B(5.0V, 4K Ref.)

• **Active Power Dissipation**

Unit : mW

Speed	8K	4K
-45	550	715
-5	495	660
-6	440	605

• **Refresh Cycles**

Part NO.	Refresh cycle	Refresh time
		Normal
KM48C8004B*	8K	64ms
KM48C8104B	4K	

- * Access mode & $\overline{\text{RAS}}$ only refresh mode : 8K cycle/64ms
- $\overline{\text{CAS}}$ -before- $\overline{\text{RAS}}$ & Hidden refresh mode : 4K cycle/64ms

• **Performance Range**

Speed	t _{RAC}	t _{CAC}	t _{RC}	t _{HPC}
-45	45ns	12ns	74ns	17ns
-5	50ns	13ns	84ns	20ns
-6	60ns	15ns	104ns	25ns

- Extended Data Out Mode operation
- $\overline{\text{CAS}}$ -before- $\overline{\text{RAS}}$ refresh capability
- $\overline{\text{RAS}}$ -only and Hidden refresh capability
- Fast parallel test mode capability
- TTL(5.0V) compatible inputs and outputs
- Early Write or output enable controlled write
- JEDEC Standard pinout
- Available in Plastic SOJ and TSOP(II) packages
- +5.0V±10% power supply

FUNCTIONAL BLOCK DIAGRAM

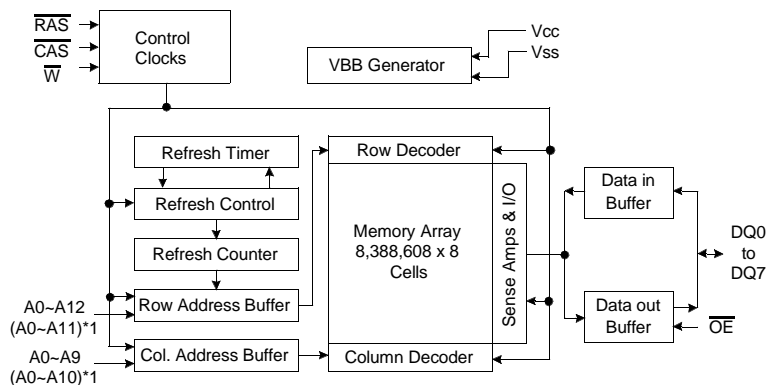

Note) *1 : 4K Refresh

SAMSUNG ELECTRONICS CO., LTD. reserves the right to change products and specifications without notice.

PIN CONFIGURATION (Top Views)

• KM48V80(1)04BK

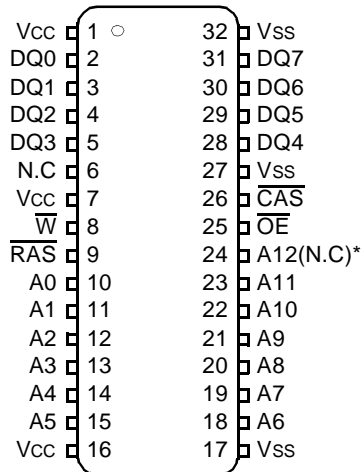

(K : 400mil SOJ)

• KM48V80(1)04BS

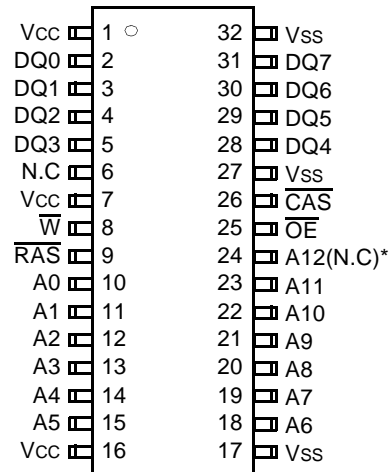

(S : 400mil TSOP(II))

* (N.C) : N.C for 4K Refresh product

Pin Name	Pin Function
A0 - A12	Address Inputs(8K Product)
A0 - A11	Address Inputs(4K Product)
DQ0 - 7	Data In/Out
Vss	Ground
\overline{RAS}	Row Address Strobe
\overline{CAS}	Column Address Strobe
\overline{W}	Read/Write Input
\overline{OE}	Data Output Enable
Vcc	Power(+5.0V)
N.C	No Connection

ABSOLUTE MAXIMUM RATINGS

Parameter	Symbol	Rating	Units
Voltage on any pin relative to Vss	V _{IN} , V _{OUT}	-1.0 to +7.0	V
Voltage on Vcc supply relative to Vss	V _{CC}	-1.0 to +7.0	V
Storage Temperature	T _{stg}	-55 to +150	°C
Power Dissipation	P _D	1	W
Short Circuit Output Current	I _{OS}	50	mA

* Permanent device damage may occur if "ABSOLUTE MAXIMUM RATINGS" are exceeded. Functional operation should be restricted to the conditions as detailed in the operational sections of this data sheet. Exposure to absolute maximum rating conditions for extended periods may affect device reliability.

RECOMMENDED OPERATING CONDITIONS (Voltage referenced to Vss, T_A= 0 to 70°C)

Parameter	Symbol	Min	Typ	Max	Units
Supply Voltage	V _{CC}	4.5	5.0	5.5	V
Ground	V _{SS}	0	0	0	V
Input High Voltage	V _{IH}	2.4	-	V _{CC} +1.0* ¹	V
Input Low Voltage	V _{IL}	-1.0* ²	-	0.8	V

*1 : V_{CC}+2.0V at pulse width ≤ 20ns which is measured at V_{CC}

*2 : -2.0 at pulse width ≤ 20ns which is measured at V_{SS}

DC AND OPERATING CHARACTERISTICS (Recommended operating conditions unless otherwise noted.)

Parameter	Symbol	Min	Max	Units
Input Leakage Current (Any input 0 ≤ V _{IN} ≤ V _{CC} +0.5V, all other pins not under test=0 Volt)	I _{I(L)}	-5	5	uA
Output Leakage Current (Data out is disabled, 0V ≤ V _{OUT} ≤ V _{CC})	I _{O(L)}	-5	5	uA
Output High Voltage Level(I _{OH} =-5mA)	V _{OH}	2.4	-	V
Output Low Voltage Level(I _{OL} =4.2mA)	V _{OL}	-	0.4	V

DC AND OPERATING CHARACTERISTICS (Continued)

Symbol	Power	Speed	Max		Units
			KM48C8004B	KM48C8104B	
I _{CC1}	Don't care	-45	100	130	mA
		-5	90	120	mA
		-6	80	110	mA
I _{CC2}	Normal	Don't care	2	2	mA
I _{CC3}	Don't care	-45	100	130	mA
		-5	90	120	mA
		-6	80	110	mA
I _{CC4}	Don't care	-45	110	120	mA
		-5	100	110	mA
		-6	90	100	mA
I _{CC5}	Normal	Don't care	1	1	mA
I _{CC6}	Don't care	-45	100	130	mA
		-5	90	120	mA
		-6	80	110	mA

I_{CC1}* : Operating Current (\overline{RAS} and \overline{CAS} , Address cycling @trc=min.)

I_{CC2} : Standby Current ($\overline{RAS}=\overline{CAS}=\overline{W}=V_{IH}$)

I_{CC3}* : \overline{RAS} -only Refresh Current ($\overline{CAS}=V_{IH}$, \overline{RAS} , Address cycling @trc=min.)

I_{CC4}* : Extended Data Out Mode Current ($\overline{RAS}=V_{IL}$, \overline{CAS} , Address cycling @tHPC=min.)

I_{CC5} : Standby Current ($\overline{RAS}=\overline{CAS}=\overline{W}=V_{CC}-0.2V$)

I_{CC6}* : \overline{CAS} -Before- \overline{RAS} Refresh Current (\overline{RAS} and \overline{CAS} cycling @trc=min)

***Note :** I_{CC1}, I_{CC3}, I_{CC4} and I_{CC6} are dependent on output loading and cycle rates. Specified values are obtained with the output open. I_{CC} is specified as an average current. In I_{CC1}, I_{CC3} and I_{CC6}, address can be changed maximum once while $\overline{RAS}=V_{IL}$. In I_{CC4}, address can be changed maximum once within one EDO mode cycle time, tHPC.

CAPACITANCE ($T_A=25^\circ\text{C}$, $V_{CC}=5.0\text{V}$, $f=1\text{MHz}$)

Parameter	Symbol	Min	Max	Units
Input capacitance [A0 ~ A12]	C _{IN1}	-	5	pF
Input capacitance [$\overline{\text{RAS}}$, $\overline{\text{CAS}}$, $\overline{\text{W}}$, $\overline{\text{OE}}$]	C _{IN2}	-	7	pF
Output capacitance [DQ0 - DQ7]	C _{DQ}	-	7	pF

AC CHARACTERISTICS ($0^\circ\text{C} \leq T_A \leq 70^\circ\text{C}$, See note 1,2)

 Test condition : $V_{CC}=5.0\text{V} \pm 10\%$, $V_{ih}/V_{il}=2.4/0.8\text{V}$, $V_{oh}/V_{ol}=2.0/0.8\text{V}$

Parameter	Symbol	-45		-5		-6		Units	Note
		Min	Max	Min	Max	Min	Max		
Random read or write cycle time	t _{RC}	74		84		104		ns	
Read-modify-write cycle time	t _{RWC}	101		113		138		ns	
Access time from $\overline{\text{RAS}}$	t _{RAC}		45		50		60	ns	3,4,10
Access time from $\overline{\text{CAS}}$	t _{CAC}		12		13		15	ns	3,4,5
Access time from column address	t _{AA}		23		25		30	ns	3,10
$\overline{\text{CAS}}$ to output in Low-Z	t _{CLZ}	3		3		3		ns	3
Output buffer turn-off delay from $\overline{\text{CAS}}$	t _{CEZ}	3	13	3	13	3	13	ns	6,14
$\overline{\text{OE}}$ to output in Low-Z	t _{OLZ}	3		3		3		ns	3
Transition time (rise and fall)	t _T	1	50	1	50	1	50	ns	2
$\overline{\text{RAS}}$ precharge time	t _{RP}	25		30		40		ns	
$\overline{\text{RAS}}$ pulse width	t _{RAS}	45	10K	50	10K	60	10K	ns	
$\overline{\text{RAS}}$ hold time	t _{RSH}	8		8		10		ns	
$\overline{\text{CAS}}$ hold time	t _{CSH}	35		38		40		ns	
$\overline{\text{CAS}}$ pulse width	t _{CAS}	7	5K	8	10K	10	10K	ns	
$\overline{\text{RAS}}$ to $\overline{\text{CAS}}$ delay time	t _{RCD}	11	33	11	37	14	45	ns	4
$\overline{\text{RAS}}$ to column address delay time	t _{RAD}	9	22	9	25	12	30	ns	10
$\overline{\text{CAS}}$ to $\overline{\text{RAS}}$ precharge time	t _{CRP}	5		5		5		ns	
Row address set-up time	t _{ASR}	0		0		0		ns	
Row address hold time	t _{RAH}	7		7		10		ns	
Column address set-up time	t _{ASC}	0		0		0		ns	
Column address hold time	t _{CAH}	7		7		10		ns	
Column address to $\overline{\text{RAS}}$ lead time	t _{RAL}	23		25		30		ns	
Read command set-up time	t _{RCS}	0		0		0		ns	8
Read command hold time referenced to $\overline{\text{CAS}}$	t _{RCH}	0		0		0		ns	8
Read command hold time referenced to $\overline{\text{RAS}}$	t _{RRH}	0		0		0		ns	
Write command hold time	t _{WCH}	7		7		10		ns	
Write command pulse width	t _{WP}	6		7		10		ns	
Write command to $\overline{\text{RAS}}$ lead time	t _{RWL}	8		8		10		ns	
Write command to $\overline{\text{CAS}}$ lead time	t _{CWL}	7		7		10		ns	
Data set-up time	t _{DS}	0		0		0		ns	9

AC CHARACTERISTICS (Continued)

Parameter	Symbol	-45		-5		-6		Units	Note
		Min	Max	Min	Max	Min	Max		
Data hold time	t _{DH}	7		7		10		ns	9
Refresh period (4K, Normal)	t _{REF}		64		64		64	ms	
Refresh period (8K, Normal)	t _{REF}		64		64		64	ms	
Write command set-up time	t _{WCS}	0		0		0		ns	7
$\overline{\text{CAS}}$ to $\overline{\text{W}}$ delay time	t _{CWD}	24		27		32		ns	7
$\overline{\text{RAS}}$ to $\overline{\text{W}}$ delay time	t _{RWD}	57		64		77		ns	7
Column address to $\overline{\text{W}}$ delay time	t _{AWD}	35		39		47		ns	7
$\overline{\text{CAS}}$ set-up time ($\overline{\text{CAS}}$ -before- $\overline{\text{RAS}}$ refresh)	t _{CSR}	5		5		5		ns	
$\overline{\text{CAS}}$ hold time ($\overline{\text{CAS}}$ -before- $\overline{\text{RAS}}$ refresh)	t _{CHR}	10		10		10		ns	
$\overline{\text{RAS}}$ to $\overline{\text{CAS}}$ precharge time	t _{RPC}	5		5		5		ns	
Access time from $\overline{\text{CAS}}$ precharge	t _{CPA}		24		28		35	ns	3
Hyper Page cycle time	t _{HPC}	17		20		25		ns	13
Hyper Page read-modify-write cycle time	t _{HPRWC}	47		47		56		ns	13
$\overline{\text{CAS}}$ precharge time (Hyper page cycle)	t _{CP}	6.5		7		10		ns	
$\overline{\text{RAS}}$ pulse width (Hyper page cycle)	t _{RASP}	45	200K	50	200K	60	200K	ns	
$\overline{\text{RAS}}$ hold time from $\overline{\text{CAS}}$ precharge	t _{RHCP}	24		30		35		ns	
$\overline{\text{OE}}$ access time	t _{OEA}		12		13		15	ns	
$\overline{\text{OE}}$ to data delay	t _{OED}	8		10		13		ns	
$\overline{\text{CAS}}$ precharge to $\overline{\text{W}}$ delay time	t _{CPWD}	36		41		52		ns	
Output buffer turn off delay time from $\overline{\text{OE}}$	t _{OEZ}	3	11	3	13	3	13	ns	6
$\overline{\text{OE}}$ command hold time	t _{OEH}	5		5		5		ns	
Write command set-up time (Test mode in)	t _{WTS}	10		10		10		ns	11
Write command hold time (Test mode in)	t _{WTH}	10		10		10		ns	11
$\overline{\text{W}}$ to $\overline{\text{RAS}}$ precharge time ($\overline{\text{C}}$ -B- $\overline{\text{R}}$ refresh)	t _{WRP}	10		10		10		ns	
$\overline{\text{W}}$ to $\overline{\text{RAS}}$ hold time ($\overline{\text{C}}$ -B- $\overline{\text{R}}$ refresh)	t _{WRH}	10		10		10		ns	
Output data hold time	t _{DOH}	4		5		5		ns	
Output buffer turn off delay from $\overline{\text{RAS}}$	t _{REZ}	3	13	3	13	3	13	ns	6,14
Output buffer turn off delay from $\overline{\text{W}}$	t _{WEZ}	3	13	3	13	3	13	ns	6
$\overline{\text{W}}$ to data delay	t _{WED}	8		15		15		ns	
$\overline{\text{OE}}$ to $\overline{\text{CAS}}$ hold time	t _{OCH}	5		5		5		ns	
$\overline{\text{CAS}}$ hold time to $\overline{\text{OE}}$	t _{CHO}	5		5		5		ns	
$\overline{\text{OE}}$ precharge time	t _{OEP}	5		5		5		ns	
$\overline{\text{W}}$ pulse width (Hyper page cycle)	t _{WPE}	5		5		5		ns	
$\overline{\text{RAS}}$ pulse width ($\overline{\text{C}}$ -B- $\overline{\text{R}}$ self refresh)	t _{RASS}	100		100		100		us	15,16,17
$\overline{\text{RAS}}$ precharge time ($\overline{\text{C}}$ -B- $\overline{\text{R}}$ self refresh)	t _{RPS}	74		90		110		ns	15,16,17
$\overline{\text{CAS}}$ hold time ($\overline{\text{C}}$ -B- $\overline{\text{R}}$ self refresh)	t _{CHS}	-50		-50		-50		ns	15,16,17

TEST MODE CYCLE
(Note 11)

Parameter	Symbol	-45		-5		-6		Units	Note
		Min	Max	Min	Max	Min	Max		
Random read or write cycle time	t _{RC}	79		89		109		ns	
Read-modify-write cycle time	t _{RWC}	110		121		145		ns	
Access time from $\overline{\text{RAS}}$	t _{RAC}		50		55		65	ns	3,4,10,12
Access time from $\overline{\text{CAS}}$	t _{CAC}		17		18		20	ns	3,4,5,12
Access time from column address	t _{AA}		28		30		35	ns	3,10,12
$\overline{\text{RAS}}$ pulse width	t _{RAS}	50	10K	55	10K	65	10K	ns	
$\overline{\text{CAS}}$ pulse width	t _{CAS}	12	10K	13	10K	15	10K	ns	
$\overline{\text{RAS}}$ hold time	t _{RSH}	18		18		20		ns	
$\overline{\text{CAS}}$ hold time	t _{CSH}	39		43		50		ns	
Column Address to $\overline{\text{RAS}}$ lead time	t _{RAL}	28		30		35		ns	
$\overline{\text{CAS}}$ to $\overline{\text{W}}$ delay time	t _{CWD}	29		35		39		ns	7
$\overline{\text{RAS}}$ to $\overline{\text{W}}$ delay time	t _{RWD}	62		72		84		ns	7
Column Address to $\overline{\text{W}}$ delay time	t _{AWD}	40		47		54		ns	7
Hyper Page cycle time	t _{HPC}	22		25		30		ns	13
Hyper Page read-modify-write cycle time	t _{HPRWC}	52		53		61		ns	13
$\overline{\text{RAS}}$ pulse width (Hyper page cycle)	t _{RASP}	50	200K	55	200K	65	200K	ns	
Access time from $\overline{\text{CAS}}$ precharge	t _{CPA}		29		33		40	ns	3
$\overline{\text{OE}}$ access time	t _{OE A}		17		18		20	ns	
$\overline{\text{OE}}$ to data delay	t _{OE D}	13		18		20		ns	
$\overline{\text{OE}}$ command hold time	t _{OE H}	13		18		20		ns	

NOTES

1. An initial pause of 200us is required after power-up followed by any 8 $\overline{\text{RAS}}$ -only refresh or $\overline{\text{CAS}}$ -before- $\overline{\text{RAS}}$ refresh cycles before proper device operation is achieved.
2. $V_{IH}(\text{min})$ and $V_{IL}(\text{max})$ are reference levels for measuring timing of input signals. Transition times are measured between $V_{IH}(\text{min})$ and $V_{IL}(\text{max})$ and are assumed to be 2ns for all inputs.
3. Measured with a load equivalent to 2 TTL load and 100pF.
4. Operation within the $t_{\text{RCD}}(\text{max})$ limit insures that $t_{\text{RAC}}(\text{max})$ can be met. $t_{\text{RCD}}(\text{max})$ is specified as a reference point only. If t_{RCD} is greater than the specified $t_{\text{RCD}}(\text{max})$ limit, then access time is controlled exclusively by t_{CAC} .
5. Assumes that $t_{\text{RCD}} \geq t_{\text{RCD}}(\text{max})$.
6. This parameter defines the time at which the output achieves the open circuit condition and is not referenced to V_{oh} or V_{ol} .
7. t_{WCS} , t_{RWD} , t_{CWD} and t_{AWD} are non restrictive operating parameters. They are included in the data sheet as electrical characteristics only. If $t_{\text{WCS}} \geq t_{\text{WCS}}(\text{min})$, the cycle is an early write cycle and the data output will remain high impedance for the duration of the cycle. If $t_{\text{CWD}} \geq t_{\text{CWD}}(\text{min})$, $t_{\text{RWD}} \geq t_{\text{RWD}}(\text{min})$ and $t_{\text{AWD}} \geq t_{\text{AWD}}(\text{min})$, then the cycle is a read-modify-write cycle and the data output will contain the data read from the selected address. If neither of the above conditions is satisfied, the condition of the data out is indeterminate.
8. Either t_{RCH} or t_{RRH} must be satisfied for a read cycle.
9. These parameters are referenced to $\overline{\text{CAS}}$ falling edge in early write cycles and to $\overline{\text{W}}$ falling edge in $\overline{\text{OE}}$ controlled write cycle and read-modify-write cycles.
10. Operation within the $t_{\text{RAD}}(\text{max})$ limit insures that $t_{\text{RAC}}(\text{max})$ can be met. $t_{\text{RAD}}(\text{max})$ is specified as a reference point only. If t_{RAD} is greater than the specified $t_{\text{RAD}}(\text{max})$ limit, then access time is controlled by t_{AA} .
11. These specifications are applied in the test mode.
12. In test mode read cycle, the value of t_{RAC} , t_{AA} , t_{CAC} is delayed by 2ns to 5ns for the specified values. These parameters should be specified in test mode cycles by adding the above value to the specified value in this data sheet.
13. $t_{\text{ASC}} \geq 6\text{ns}$, Assume $t_{\text{T}} = 2.0\text{ns}$
14. If $\overline{\text{RAS}}$ goes high before $\overline{\text{CAS}}$ high going, the open circuit condition of the output is achieved by $\overline{\text{CAS}}$ high going. If $\overline{\text{CAS}}$ goes high before $\overline{\text{RAS}}$ high going, the open circuit condition of the output is achieved by $\overline{\text{RAS}}$ high going.
15. If $t_{\text{RASS}} \geq 100\text{us}$, then $\overline{\text{RAS}}$ precharge time must use t_{RPS} instead of t_{RP} .
16. For $\overline{\text{RAS}}$ -only refresh and burst $\overline{\text{CAS}}$ -before- $\overline{\text{RAS}}$ refresh mode, 4096(4K/8K) cycles of burst refresh must be executed within 64ms before and after self refresh, in order to meet refresh specification.
17. For distributed $\overline{\text{CAS}}$ -before- $\overline{\text{RAS}}$ with 15.6us interval $\overline{\text{CAS}}$ -before- $\overline{\text{RAS}}$ refresh should be executed with in 15.6us immediately before and after self refresh in order to meet refresh specification.

READ CYCLE

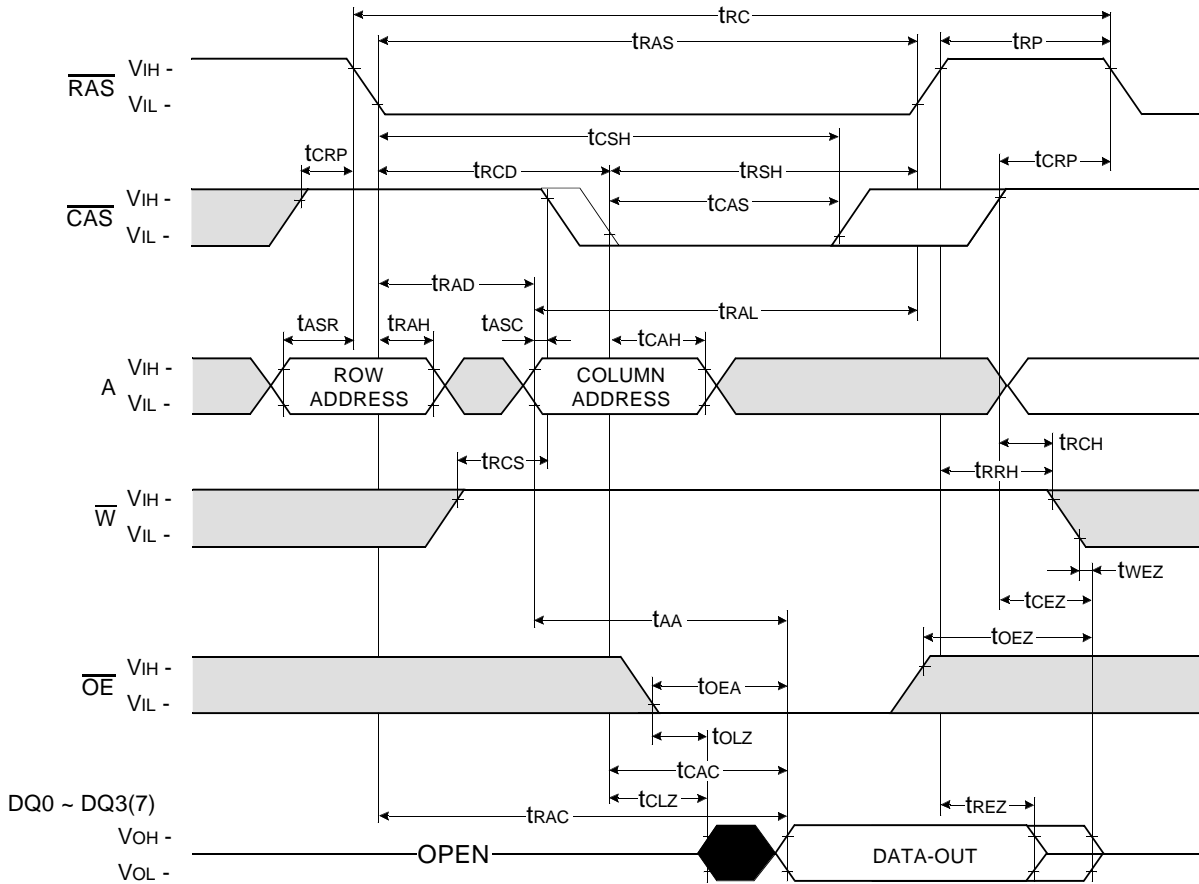

Don't care
 Undefined

WRITE CYCLE (EARLY WRITE)

NOTE : DOUT = OPEN

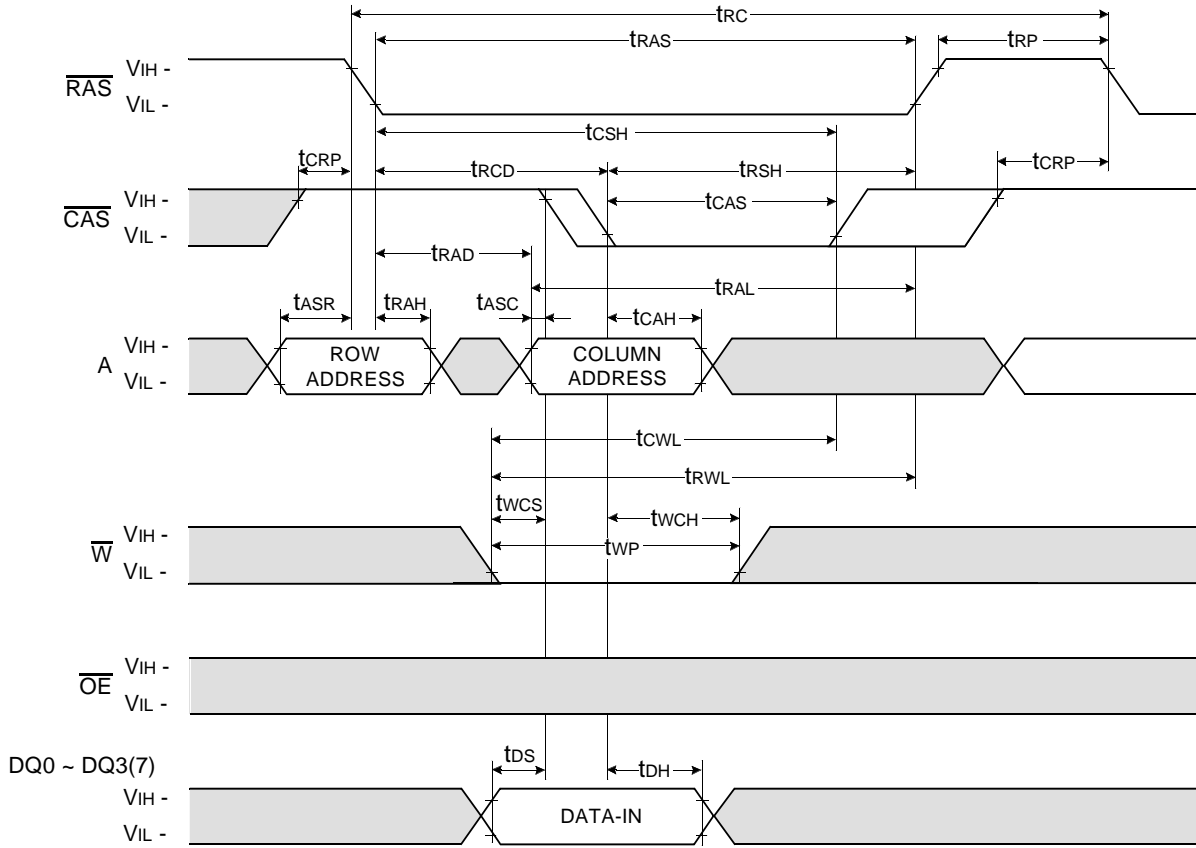

Don't care
 Undefined

WRITE CYCLE (\overline{OE} CONTROLLED WRITE)

NOTE : DOUT = OPEN

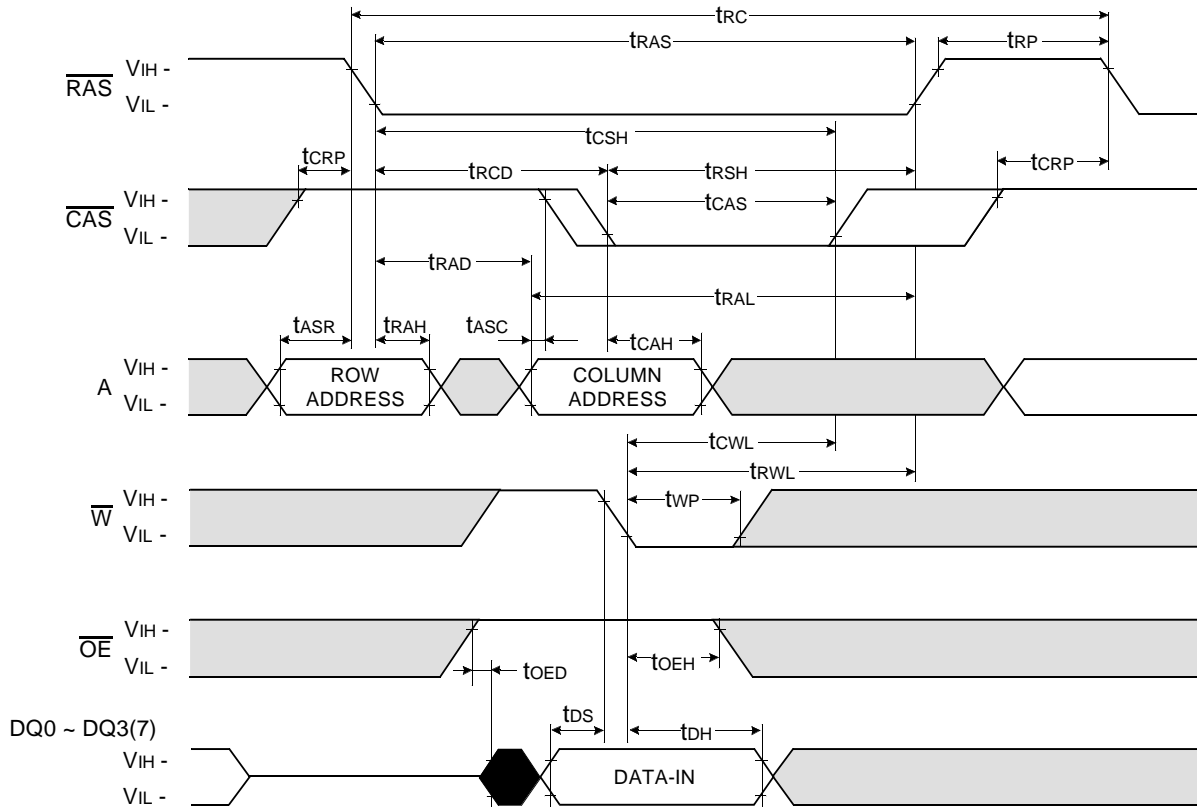

□ Don't care
 ■ Undefined

READ - MODIFY - WRITE CYCLE

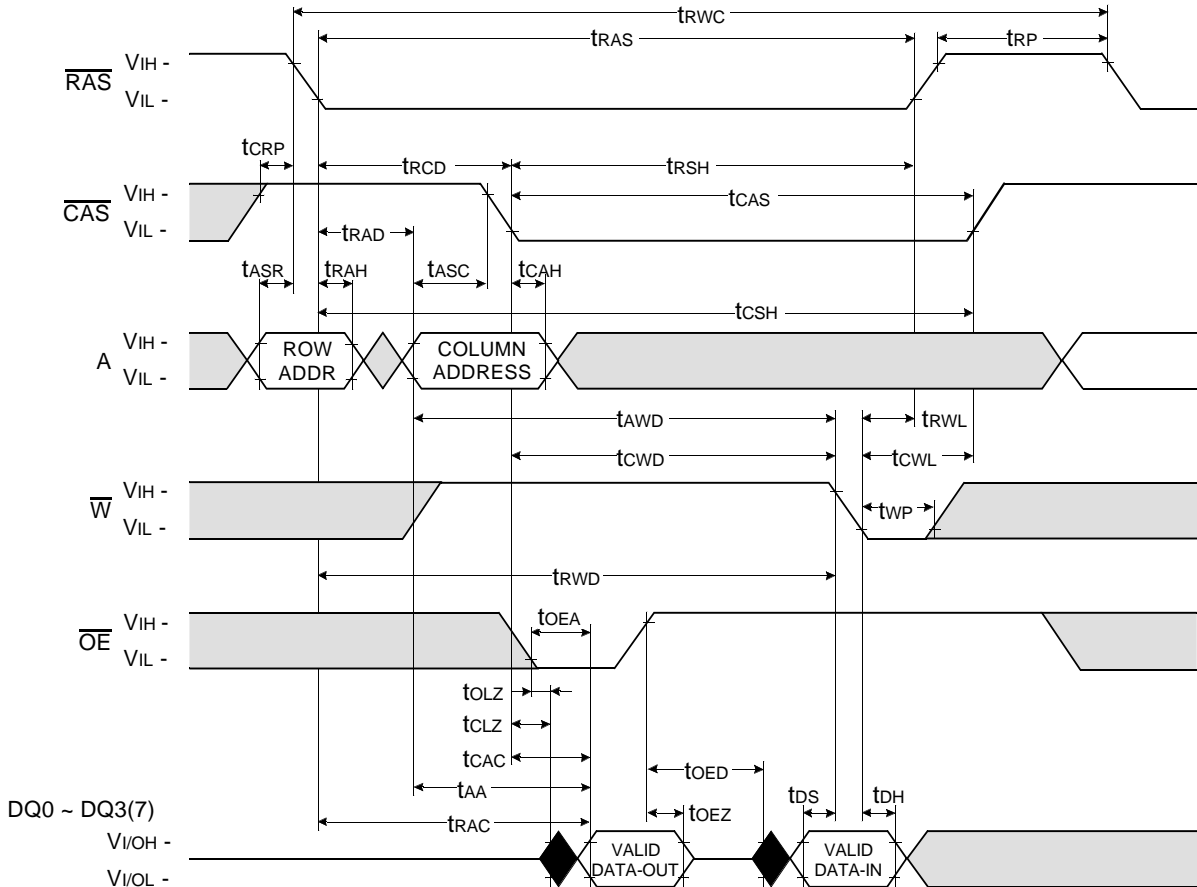

Don't care
 Undefined

HYPER PAGE WRITE CYCLE (EARLY WRITE)

NOTE : DOUT = OPEN

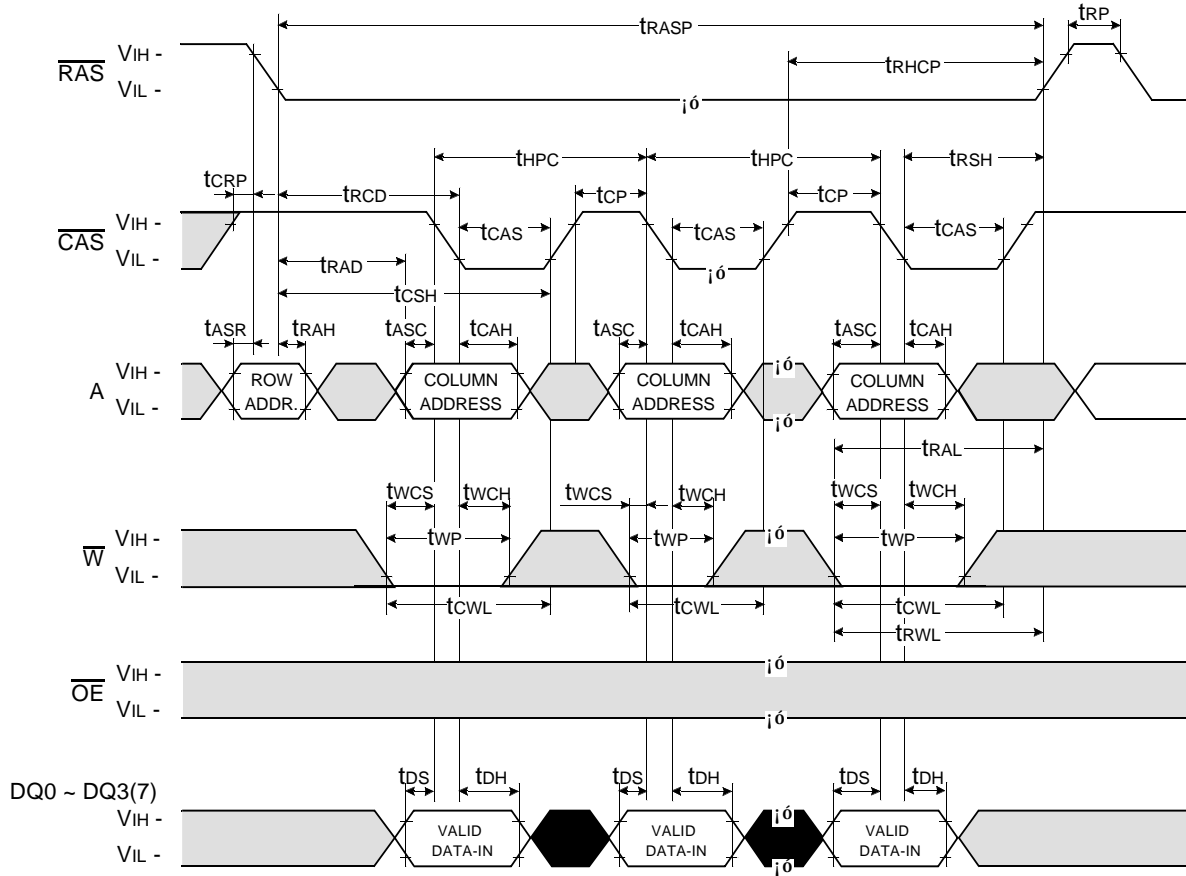

□ Don't care

■ Undefined

HYPER PAGE READ AND WRITE MIXED CYCLE

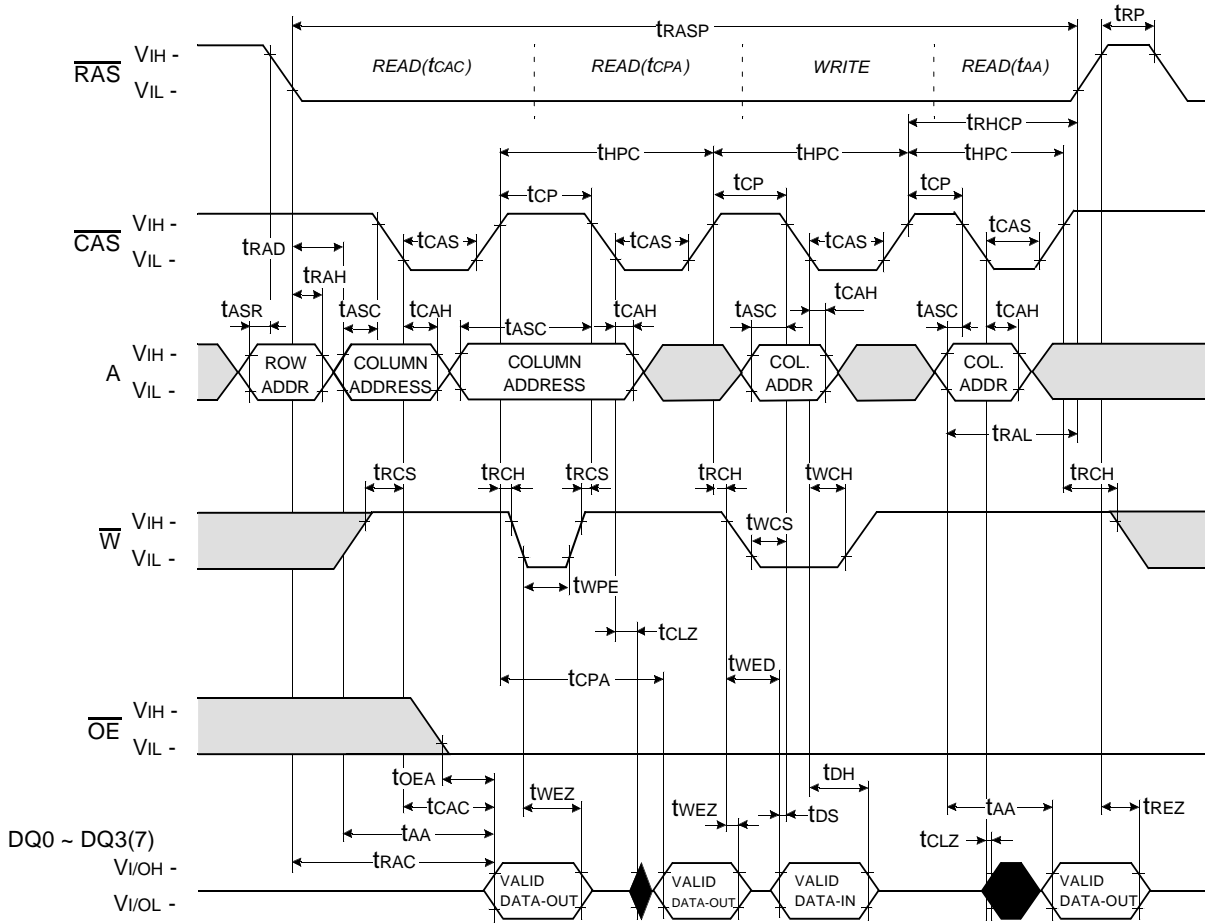

Don't care
 Undefined

$\overline{\text{RAS}}$ - ONLY REFRESH CYCLE*

NOTE : $\overline{\text{W}}$, $\overline{\text{OE}}$, DIN = Don't care

DOUT = OPEN

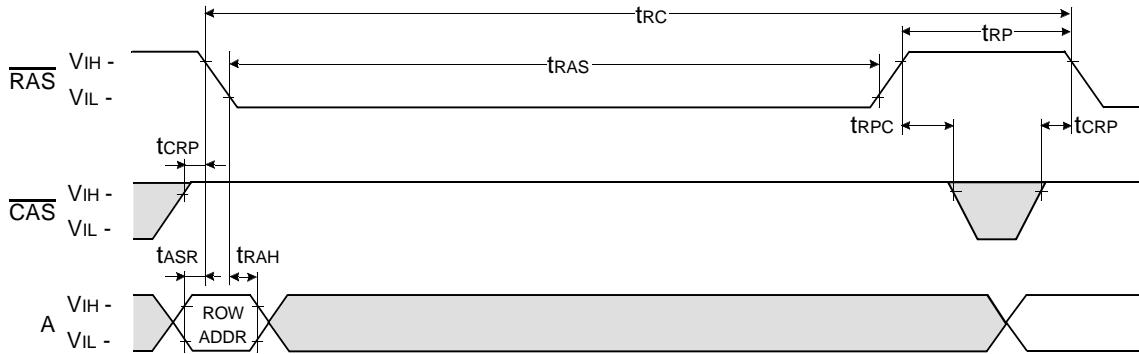

$\overline{\text{CAS}}$ - BEFORE - $\overline{\text{RAS}}$ REFRESH CYCLE

NOTE : $\overline{\text{OE}}$, A = Don't care

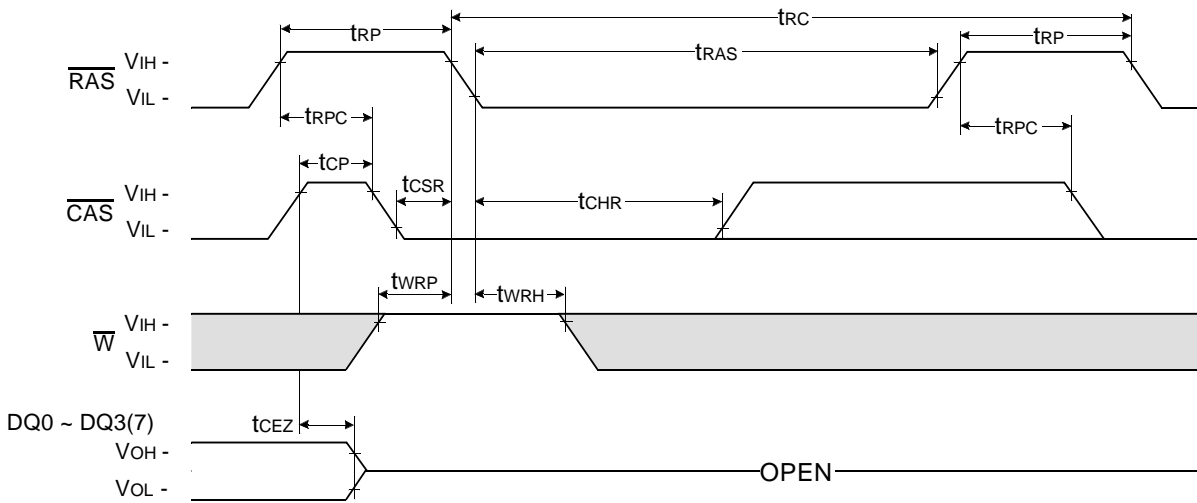

□ Don't care

■ Undefined

HIDDEN REFRESH CYCLE (READ)

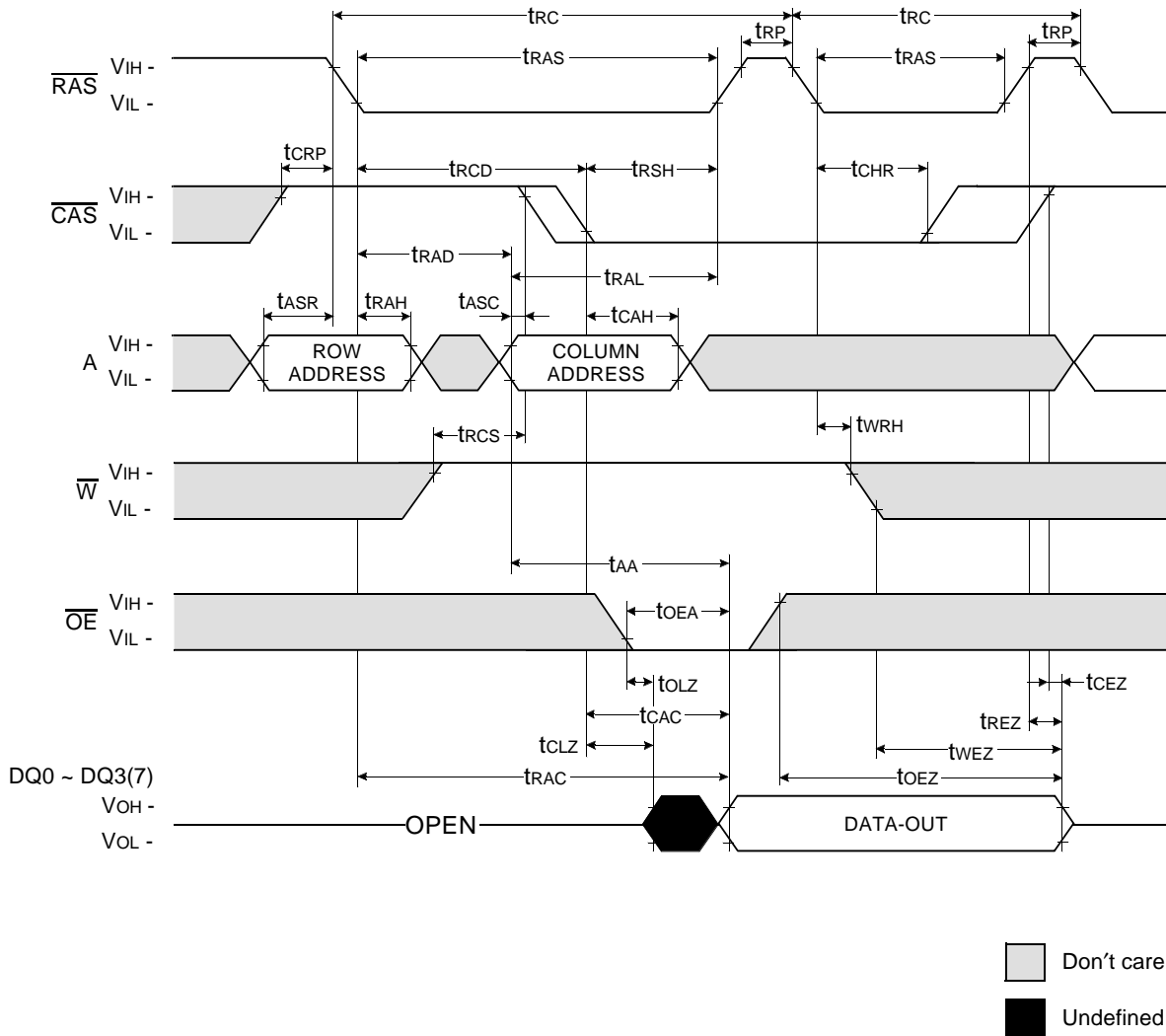

* In Hidden refresh cycle of 64Mb A-die & B-die, when \overline{CAS} signal transits from Low to High, the valid data may be cut off.

HIDDEN REFRESH CYCLE (WRITE)

NOTE : DOUT = OPEN

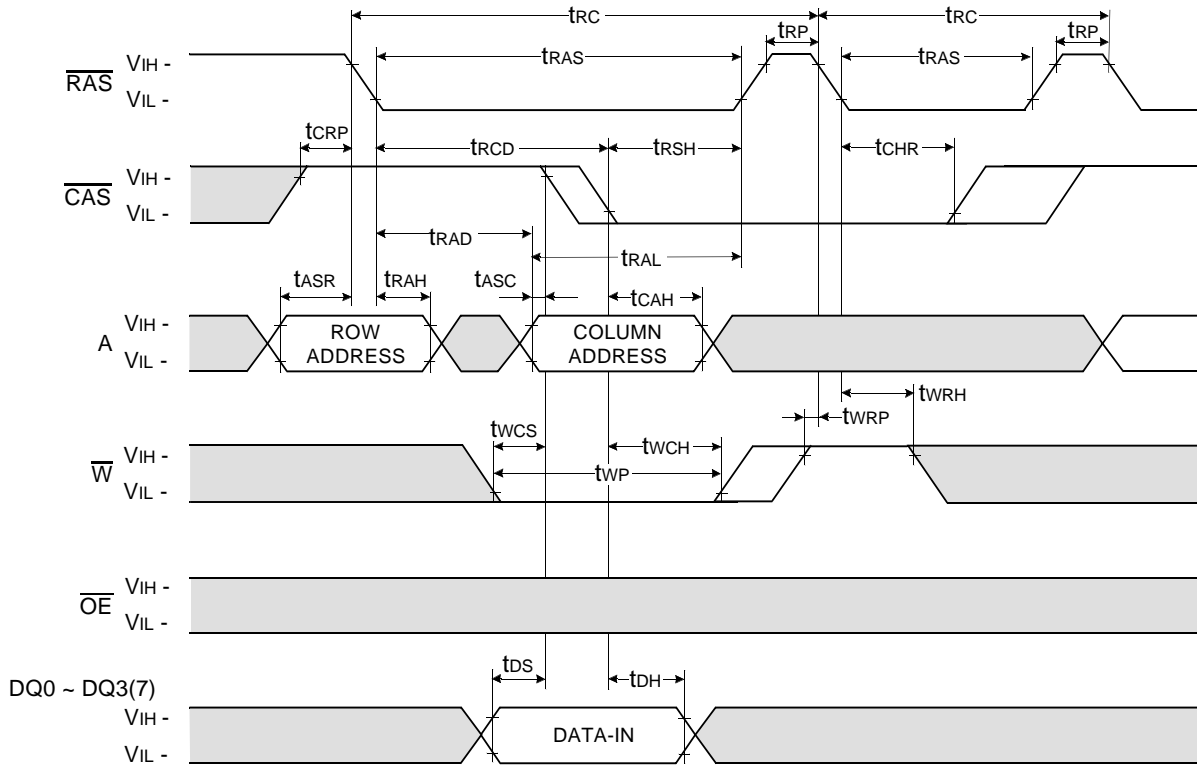

Don't care
 Undefined

$\overline{\text{CAS}}$ - BEFORE - $\overline{\text{RAS}}$ SELF REFRESH CYCLE

NOTE : $\overline{\text{OE}}$, A = Don't care

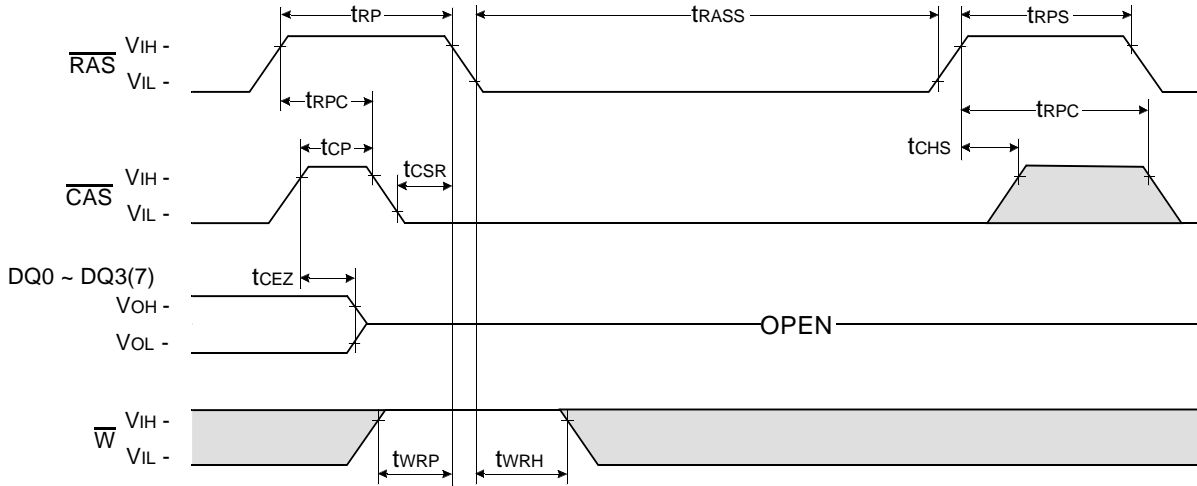

TEST MODE IN CYCLE

NOTE : $\overline{\text{OE}}$, A = Don't care

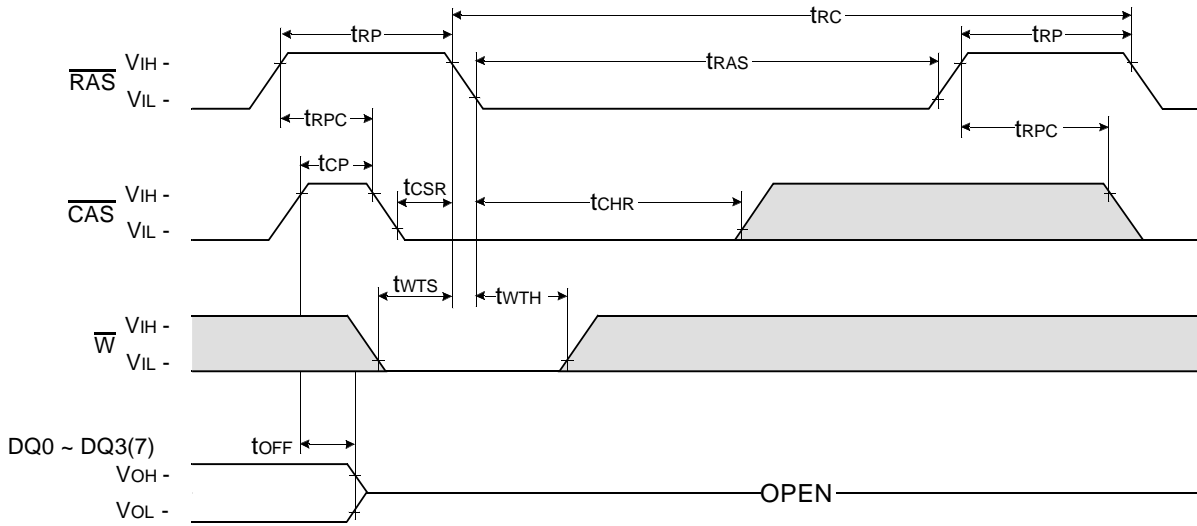

Don't care
 Undefined

PACKAGE DIMENSION

