

SI-3000N Series

3-Terminal, Full-Mold, Low Dropout Voltage Dropper Type

■Features

- Compact full-mold package (equivalent to TO220)
- Output current: 1.0A
- Low dropout voltage: $V_{DIF} \leq 1V$ (at $I_o = 1.0A$)
- Built-in foldback overcurrent, overvoltage, thermal protection circuits

■Applications

- For stabilization of the secondary stage of switching power supplies
- Electronic equipment

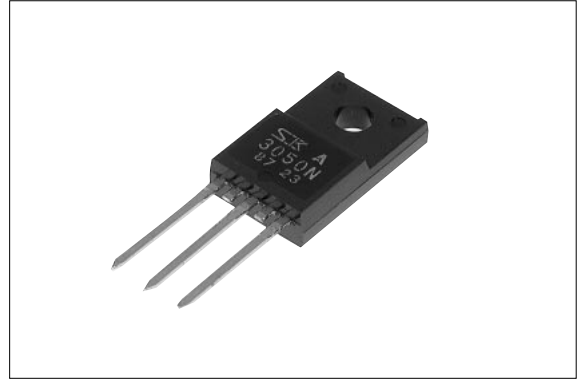

■Absolute Maximum Ratings

($T_a = 25^\circ C$)

Parameter	Symbol	Ratings			Unit
		SI-3050N	SI-3090N/3120N	SI-3150N	
DC Input Voltage	V_{IN}	25	30	35	V
DC Output Current	I_o	1.0 ²			A
Power Dissipation	P_{D1}	14(With infinite heatsink)			W
	P_{D2}	1.5(Without heatsink, stand-alone operation)			W
Junction Temperature	T_j	-40 to +125			$^\circ C$
Ambient Operating Temperature	T_{op}	-30 to +100			$^\circ C$
Storage Temperature	T_{stg}	-40 to +125			$^\circ C$
Thermal Resistance (junction to case)	$R_{th(j-c)}$	7.0			$^\circ C/W$
Thermal Resistance (junction to ambient air)	$R_{th(j-a)}$	66.7(Without heatsink, stand-alone operation)			$^\circ C/W$

■Electrical Characteristics

(Ta=25°C unless otherwise specified)

Parameter	Symbol	Ratings												Unit			
		SI-3050N			SI-3090N			SI-3120N			SI-3150N						
		min.	typ.	max.	min.	typ.	max.	min.	typ.	max.	min.	typ.	max.				
Input Voltage	V _{IN}	6 ³		15 ²	10 ³		20 ²	13 ³		25 ²	16 ³		27 ²	V			
Output Voltage	SI-3000N ^{*1}	V _O			4.80	5.00	5.20	8.64	9.00	9.36	11.52	12.00	12.48	14.40	15.00	15.60	V
	SI-3000NA	V _O			4.90	5.00	5.10	8.82	9.00	9.18	11.76	12.00	12.24	14.70	15.00	15.30	V
Dropout Voltage	V _{DIF}				0.5						0.5			V			
	Conditions	V _{IN} =8V, I _O =0.5A			V _{IN} =12V, I _O =0.5A			V _{IN} =15V, I _O =0.5A			V _{IN} =18V, I _O =0.5A						
	Conditions	I _O ≤0.5A															
Line Regulation	ΔV _{OLINE}				10			18			24			30			mV
	Conditions	V _{IN} =6 to 15V, I _O =0.5A			V _{IN} =10 to 20V, I _O =0.5A			V _{IN} =13 to 25V, I _O =0.5A			V _{IN} =16 to 27V, I _O =0.5A						
	Conditions	I _O ≤1.0A															
Load Regulation	ΔV _{OLOAD}				40			70			93			120			mV
	Conditions	V _{IN} =8V, I _O =0 to 1.0A			V _{IN} =12V, I _O =0 to 1.0A			V _{IN} =15V, I _O =0 to 1.0A			V _{IN} =18V, I _O =0 to 1.0A						
Temperature Coefficient of Output Voltage	ΔV _O /ΔT _a				±0.5			±1.0			±1.5			±1.5			mV/°C
	Conditions	V _{IN} =8V, I _O =5mA, T _J =0 to 100°C			V _{IN} =12V, I _O =5mA, T _J =0 to 100°C			V _{IN} =15V, I _O =5mA, T _J =0 to 100°C			V _{IN} =18V, I _O =5mA, T _J =0 to 100°C						
Ripple Rejection	R _{REJ}				54			54			54			54			dB
	Conditions	V _{IN} =8V, f=100 to 120Hz			V _{IN} =12V, f=100 to 120Hz			V _{IN} =15V, f=100 to 120Hz			V _{IN} =18V, f=100 to 120Hz						
Quiescent Circuit Current	I _q				3			3			3			3			mA
	Conditions	V _{IN} =8V, I _O =0A			V _{IN} =12V, I _O =0A			V _{IN} =15V, I _O =0A			V _{IN} =18V, I _O =0A						
Overcurrent Protection Starting Current ^{*4,5}	I _{S1}	1.2			1.2			1.2			1.2			A			
	Conditions	V _{IN} =8V			V _{IN} =12V			V _{IN} =15V			V _{IN} =18V						

*1: "A" may be indicated to the right of the Sanken logo.

*2: V_{IN(max)} and I_{O(max)} are restricted by the relation P_{D(max)}=(V_{IN}-V_O)•I_O=14(W).

*3: Refer to the dropout voltage.(Refer to Setting DC Input Voltage on page 7.)

*4: I_{S1} is specified at -5(%) drop point of output voltage V_O on the condition that V_{IN}=V_O+3V, I_O=0.5A.

*5: A foldback type overcurrent protection circuit is built into the IC regulator. Therefore, avoid using it for the following applications as it may cause starting errors:

- (1) Constant current load (2) Plus/minus power (3) Series power (4) V_O adjustment by raising ground voltage

■Outline Drawing

(unit: mm)

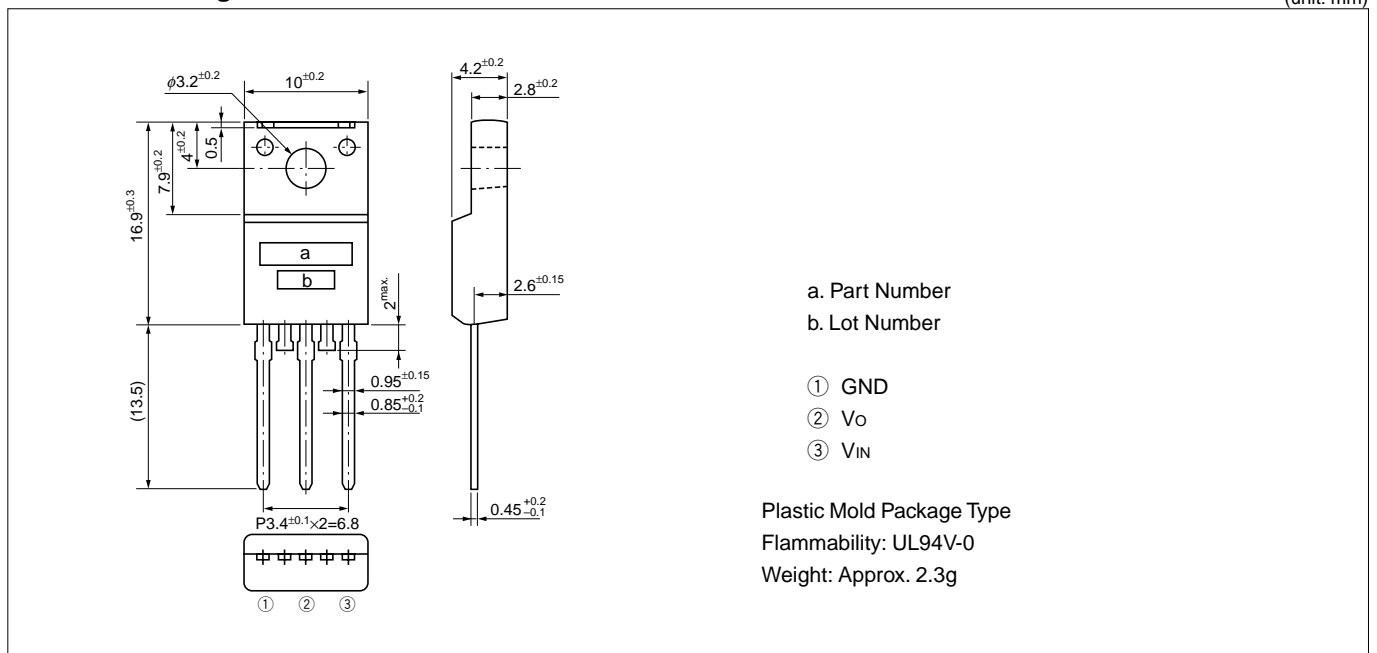

■Block Diagram

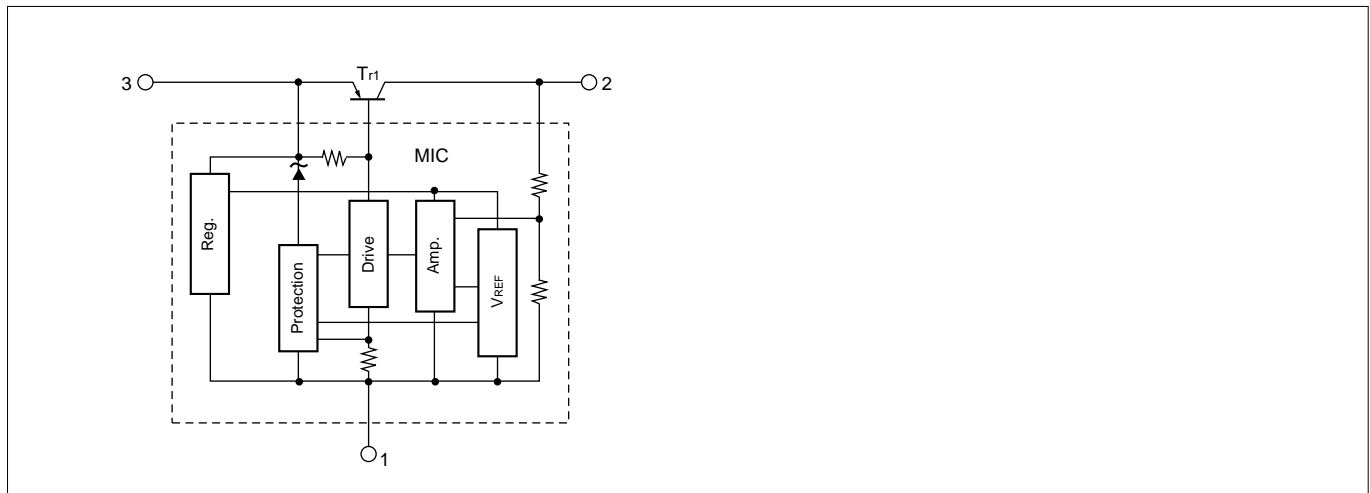

■Standard External Circuit

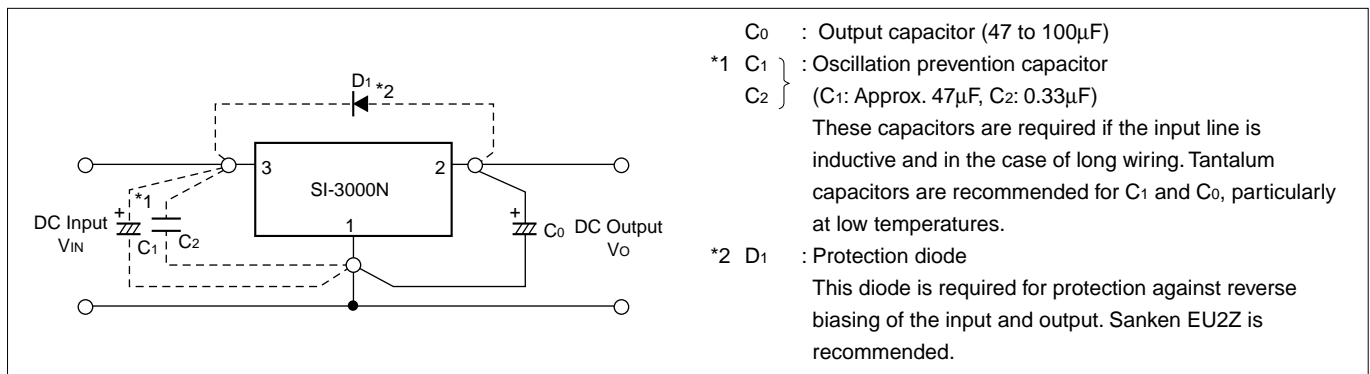

■ T_a - P_D Characteristics

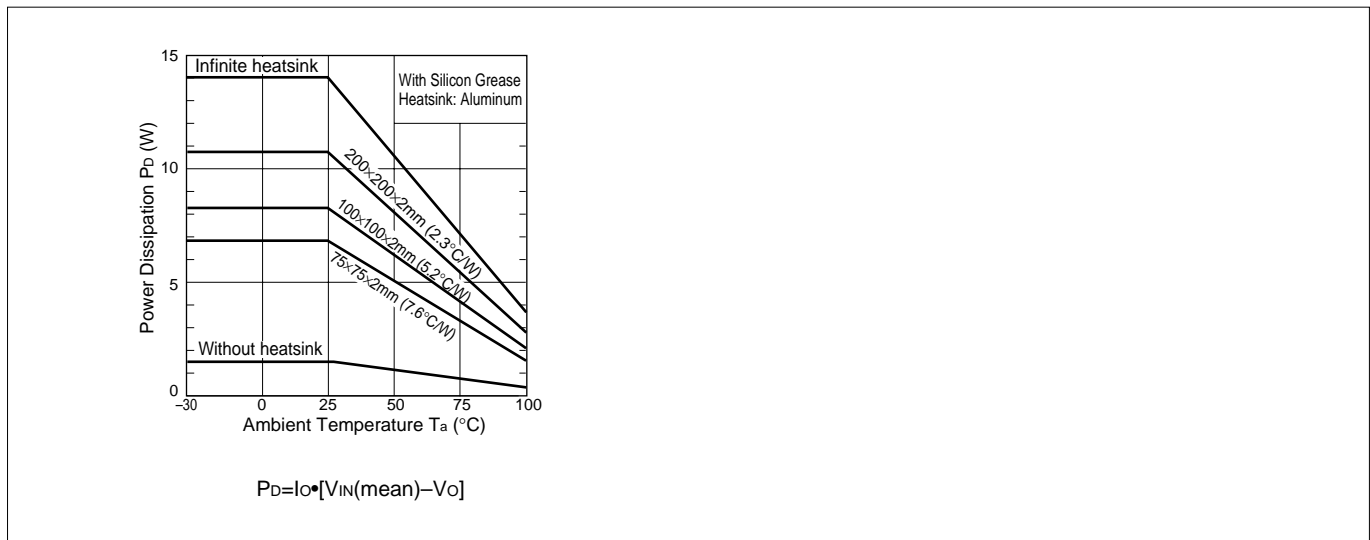

■Typical Characteristics

($T_a=25^\circ\text{C}$)

I_o vs. V_{DIF} Characteristics

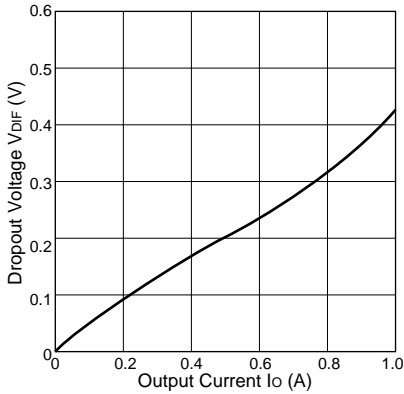

Temperature Coefficient of Output Voltage(SI-3050N)

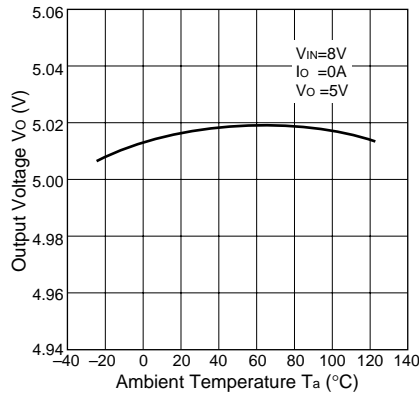

Rise Characteristics(SI-3050N)

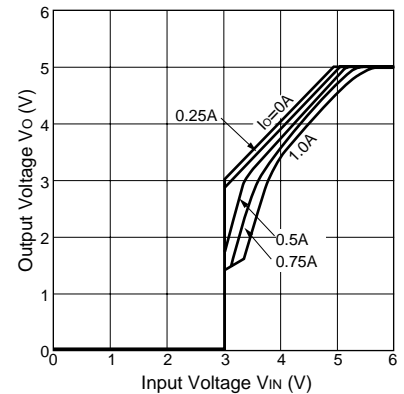

Rise Characteristics(SI-3120N)

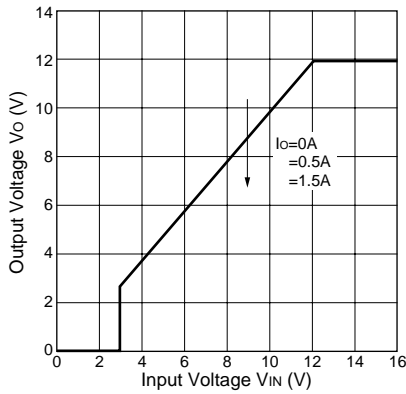

Overcurrent Protection Characteristics(SI-3050N)

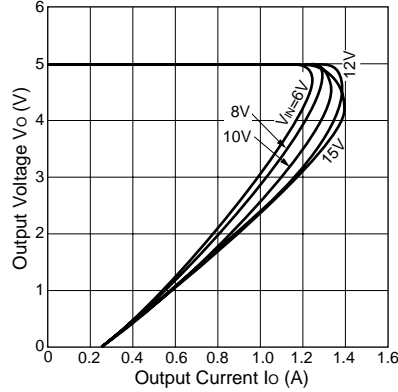

Overcurrent Protection Characteristics(SI-3120N)

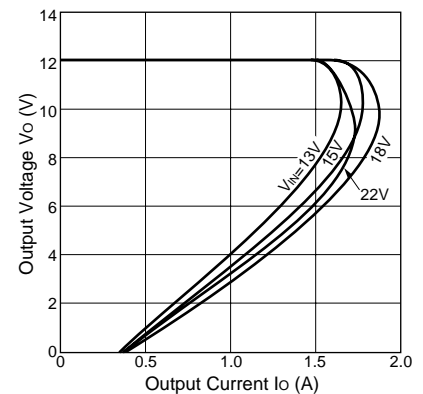

Thermal Protection Characteristics(SI-3050N)

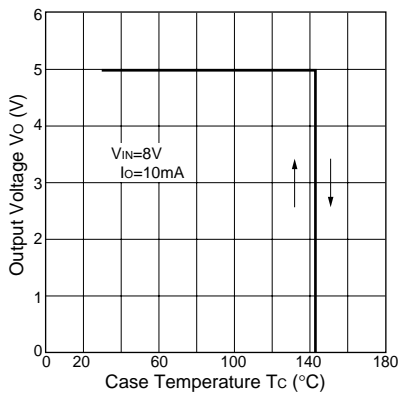

Note on Thermal Protection:

The thermal protection circuit is intended for protection against heat during instantaneous short-circuiting. Its operation is not guaranteed for short-circuiting over extended periods of time.