

# 2-Phase Stepper Motor Unipolar Driver ICs

## Absolute Maximum Ratings

(Ta=25°C)

Parameter	Symbol	Ratings			Units
		SLA7027MU	SLA7024M	SLA7026M	
Motor supply voltage	V <sub>CC</sub>	46			V
FET Drain-Source voltage	V <sub>DSS</sub>	100			V
Control supply voltage	V <sub>S</sub>	46			V
TTL input voltage	V <sub>IN</sub>	7			V
Reference voltage	V <sub>REF</sub>	2			V
Output current	I <sub>O</sub>	1	1.5	3	A
Power dissipation	P <sub>D1</sub>	4.5 (Without Heatsink)			W
	P <sub>D2</sub>	35 (T <sub>C</sub> =25°C)			W
Channel temperature	T <sub>ch</sub>	+150			°C
Storage temperature	T <sub>stg</sub>	-40 to +150			°C

## Electrical Characteristics

Parameter	Symbol	Ratings									Units
		SLA7027MU			SLA7024M			SLA7026M			
		min	typ	max	min	typ	max	min	typ	max	
Control supply current	I <sub>S</sub>		10	15		10	15		10	15	mA
	Condition	V <sub>S</sub> =44V			V <sub>S</sub> =44V			V <sub>S</sub> =44V			
Control supply voltage	V <sub>S</sub>	10	24	44	10	24	44	10	24	44	V
FET Drain-Source voltage	V <sub>DSS</sub>	100			100			100			V
	Condition	V <sub>S</sub> =44V, I <sub>DSS</sub> =250μA			V <sub>S</sub> =44V, I <sub>DSS</sub> =250μA			V <sub>S</sub> =44V, I <sub>DSS</sub> =250μA			
FET ON voltage	V <sub>DS</sub>			0.85			0.6			0.85	V
	Condition	I <sub>D</sub> =1A, A <sub>V</sub> S=14V			I <sub>D</sub> =1A, V <sub>S</sub> =14V			I <sub>D</sub> =3A, V <sub>S</sub> =14V			
FET drain leakage current	I <sub>DSS</sub>			4			4			4	mA
	Condition	V <sub>DSS</sub> =100V, V <sub>S</sub> =44V			V <sub>DSS</sub> =100V, V <sub>S</sub> =44V			V <sub>DSS</sub> =100V, V <sub>S</sub> =44V			
FET diode forward voltage	V <sub>SD</sub>			1.2			1.1			2.3	V
	Condition	I <sub>D</sub> =1A			I <sub>D</sub> =1A			I <sub>D</sub> =3A			
TTL input current	I <sub>IH</sub>			40			40			40	μA
	Condition	V <sub>IH</sub> =2.4V, V <sub>S</sub> =44V			V <sub>IH</sub> =2.4V, V <sub>S</sub> =44V			V <sub>IH</sub> =2.4V, V <sub>S</sub> =44V			
	I <sub>IL</sub>			-0.8			-0.8			-0.8	mA
	Condition	V <sub>IL</sub> =0.4V, V <sub>S</sub> =44V			V <sub>IL</sub> =0.4V, V <sub>S</sub> =44V			V <sub>IL</sub> =0.4V, V <sub>S</sub> =44V			
TTL input voltage (Active High)	V <sub>IH</sub>	2			2			2			V
	Condition	I <sub>D</sub> =1A			I <sub>D</sub> =1A			I <sub>D</sub> =3A			
	V <sub>IL</sub>			0.8			0.8			0.8	
	Condition	V <sub>DSS</sub> =100V			V <sub>DSS</sub> =100V			V <sub>DSS</sub> =100V			
TTL input voltage (Active Low)	V <sub>IH</sub>	2			2			2			V
	Condition	V <sub>DSS</sub> =100V			V <sub>DSS</sub> =100V			V <sub>DSS</sub> =100V			
	V <sub>IL</sub>			0.8			0.8			0.8	
	Condition	I <sub>D</sub> =1A			I <sub>D</sub> =1A			I <sub>D</sub> =3A			
Switching time	T <sub>r</sub>		0.5			0.5			0.5		μs
	Condition	V <sub>S</sub> =24V, I <sub>D</sub> =0.8A			V <sub>S</sub> =24V, I <sub>D</sub> =1A			V <sub>S</sub> =24V, I <sub>D</sub> =1A			
	T <sub>stg</sub>		0.7			0.7			0.7		
	Condition	V <sub>S</sub> =24V, I <sub>D</sub> =0.8A			V <sub>S</sub> =24V, I <sub>D</sub> =1A			V <sub>S</sub> =24V, I <sub>D</sub> =1A			
	T <sub>f</sub>		0.1			0.1			0.1		
	Condition	V <sub>S</sub> =24V, I <sub>D</sub> =0.8A			V <sub>S</sub> =24V, I <sub>D</sub> =1A			V <sub>S</sub> =24V, I <sub>D</sub> =1A			

Internal Block Diagram

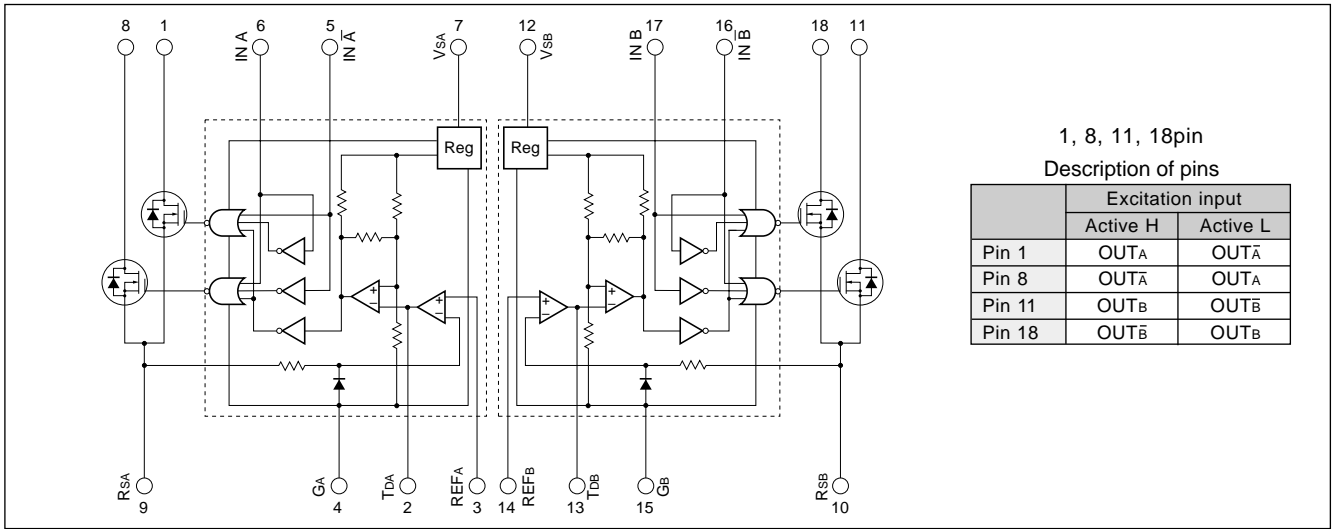
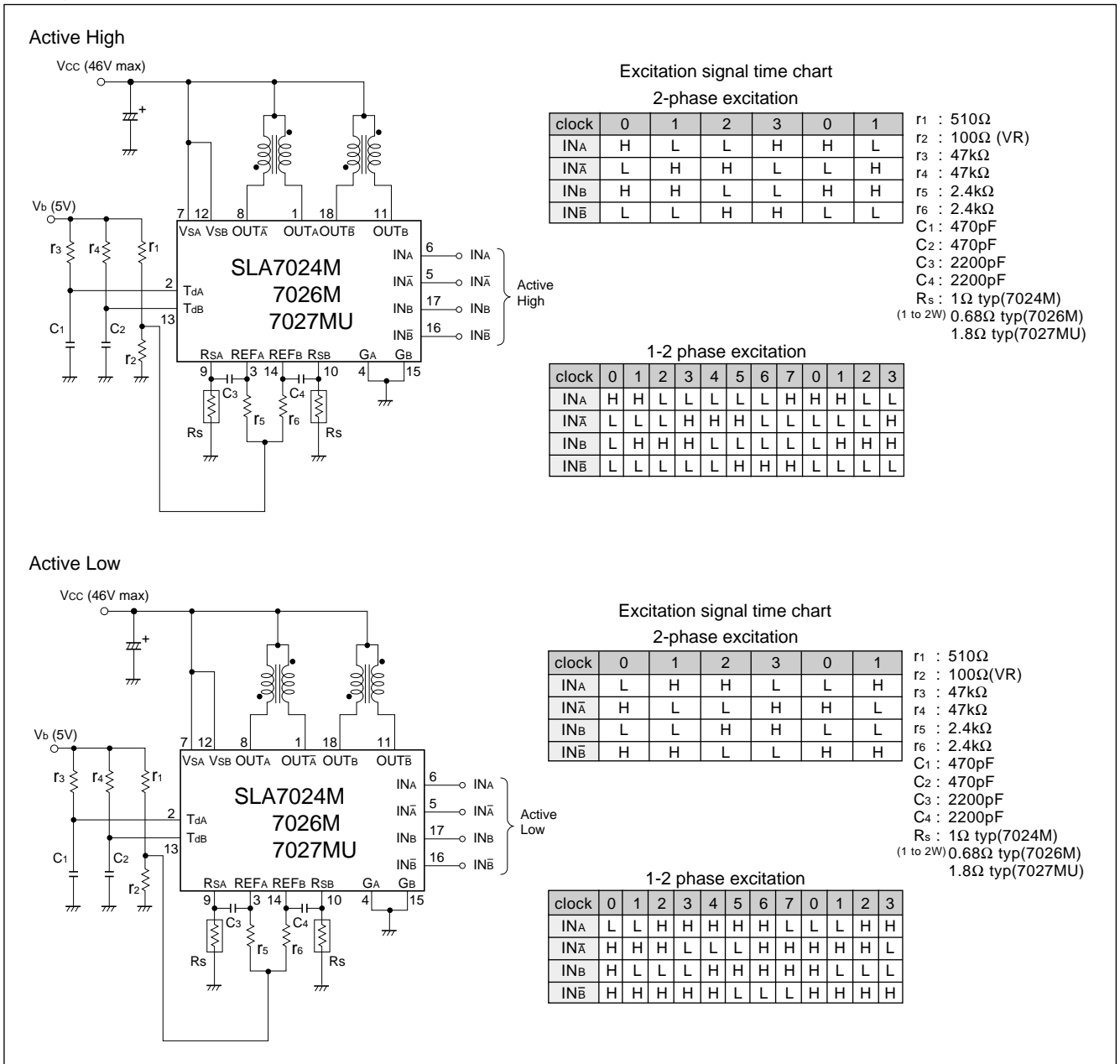
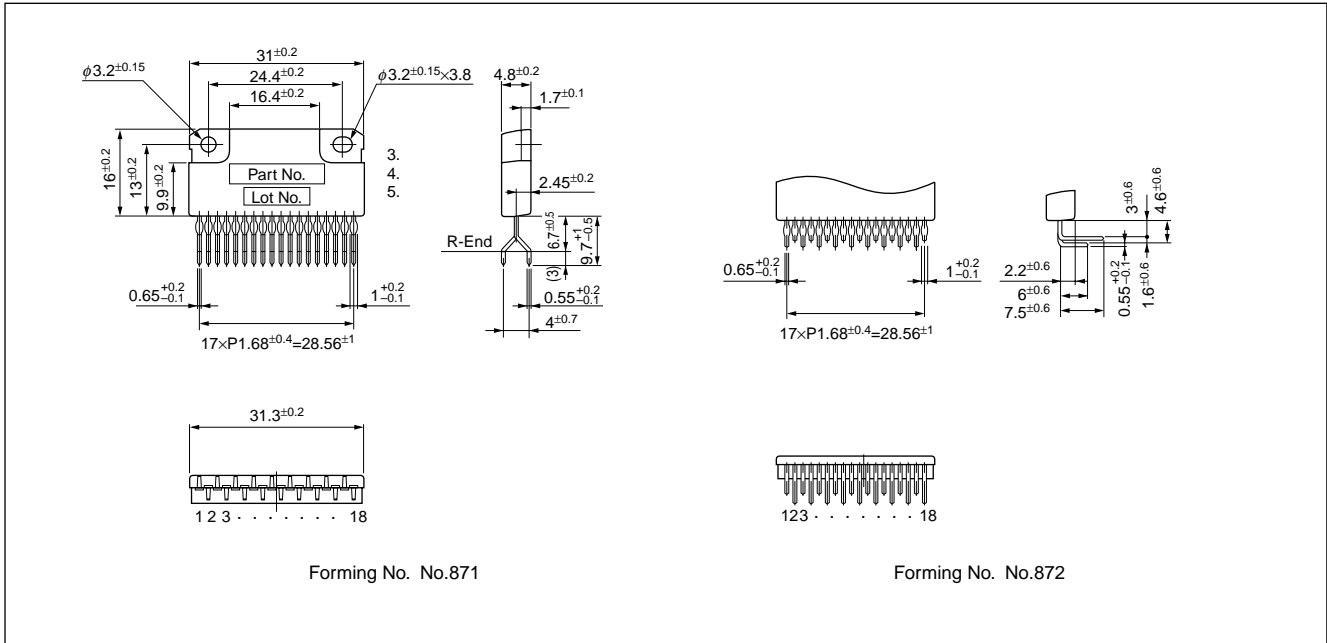

Diagram of Standard External Circuit(Recommended Circuit Constants)



External Dimensions

(Unit: mm)



# Application Notes

## Determining the Output Current

Fig. 1 shows the waveform of the output current (motor coil current). The method of determining the peak value of the output current ( $I_o$ ) based on this waveform is shown below.

(Parameters for determining the output current  $I_o$ )

$V_b$ : Reference supply voltage

$r_1, r_2$ : Voltage-divider resistors for the reference supply voltage

$R_s$ : Current sense resistor

(1) Normal rotation mode

$I_o$  is determined as follows when current flows at the maximum level during motor rotation. (See Fig.2.)

$$I_o \cong \frac{r_2}{r_1+r_2} \cdot \frac{V_b}{R_s} \dots\dots\dots (1)$$

(2) Power down mode

The circuit in Fig.3 ( $r_x$  and  $T_r$ ) is added in order to decrease the coil current.  $I_o$  is then determined as follows.

$$I_{OPD} \cong \frac{1}{1 + \frac{r_1(r_2+r_x)}{r_2 \cdot r_x}} \cdot \frac{V_b}{R_s} \dots\dots\dots (2)$$

Equation (2) can be modified to obtain equation to determine  $r_x$ .

$$r_x = \frac{1}{\frac{1}{r_1} \left( \frac{V_b}{R_s \cdot I_{OPD}} - 1 \right) - \frac{1}{r_2}}$$

Fig. 4 and 5 show the graphs of equations (1) and (2) respectively.

Fig. 1 Waveform of coil current (Phase A excitation ON)

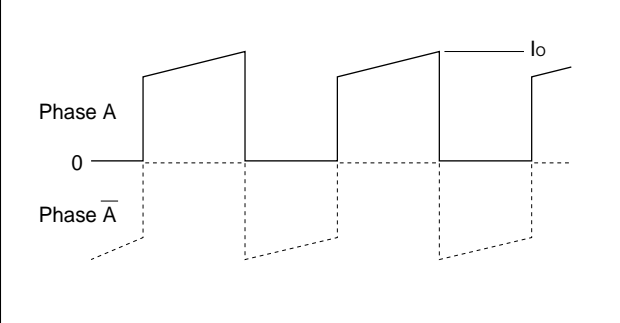

Fig. 2 Normal mode

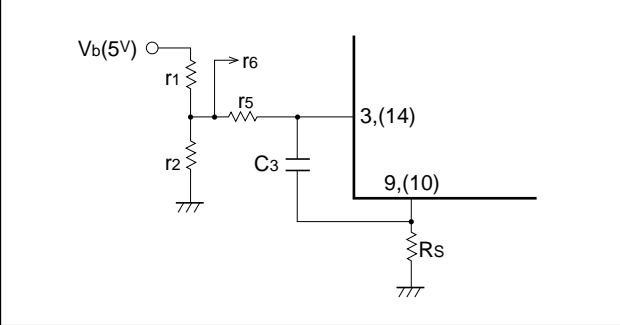

Fig. 3 Power down mode

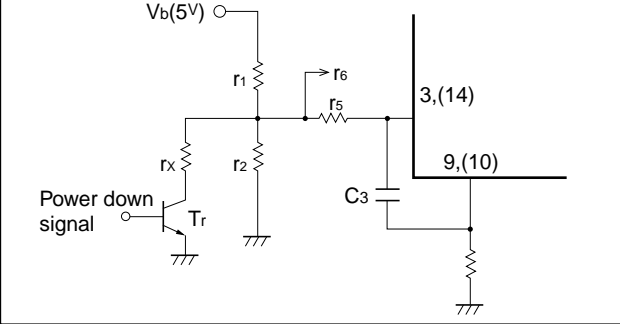

Fig. 4 Output current  $I_o$  vs. Current sense resistor  $R_s$

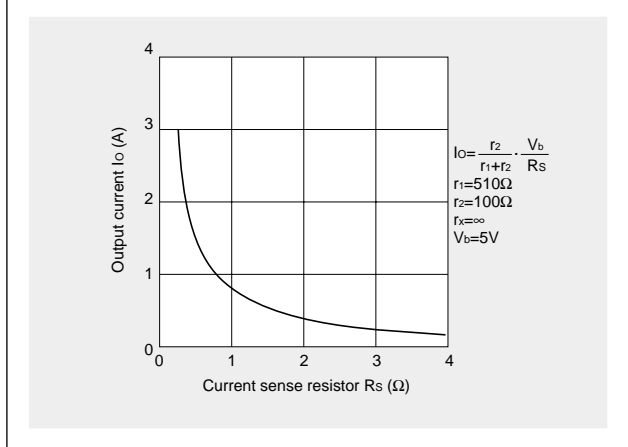
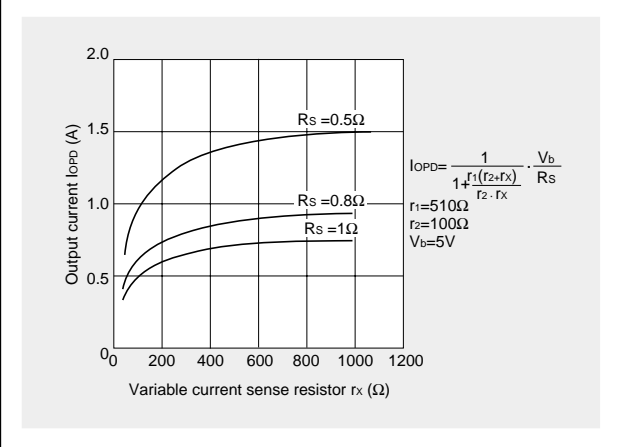

Fig. 5 Output current  $I_{OPD}$  vs. Variable current sense resistor  $r_x$



**(NOTE)**

Ringing noise is produced in the current sense resistor  $R_s$  when the MOSFET is switched ON and OFF by chopping. This noise is also generated in feedback signals from  $R_s$  which may therefore cause the comparator to malfunction. To prevent chopping malfunctions,  $r_5(r_6)$  and  $C_3(C_4)$  are added to act as a noise filter.

However, when the values of these constants are increased, the response from  $R_s$  to the comparator becomes slow. Hence the value of the output current  $I_o$  is somewhat higher than the calculated value.

**Determining the chopper frequency**

Determining  $T_{OFF}$

The SLA7000M series are self-excited choppers. The chopping OFF time  $T_{OFF}$  is fixed by  $r_3/C_1$  and  $r_4/C_2$  connected to terminal Td.

$T_{OFF}$  can be calculated using the following formula:

$$T_{OFF} \approx -r_3 \cdot C_1 \ln\left(1 - \frac{2}{V_b}\right) = -r_4 \cdot C_2 \ln\left(1 - \frac{2}{V_b}\right)$$

The circuit constants and the  $T_{OFF}$  value shown below are recommended.

$T_{OFF} = 12\mu s$  at  $r_3=47k\Omega$ ,  $C_1=500pF$ ,  $V_b=5V$

**Fig. 6 Chopper frequency vs. Motor coil resistance**

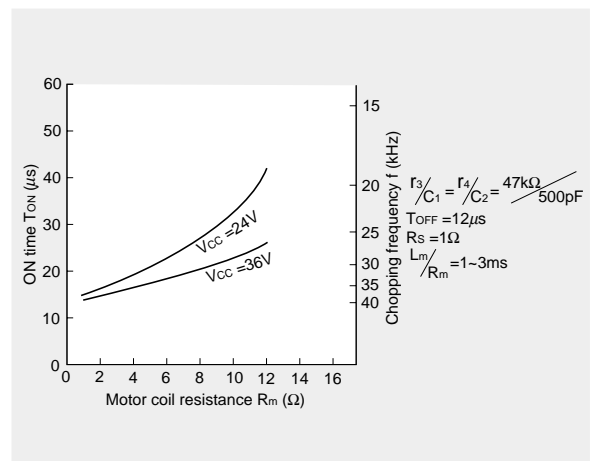

**Chopper frequency vs. Supply voltage**

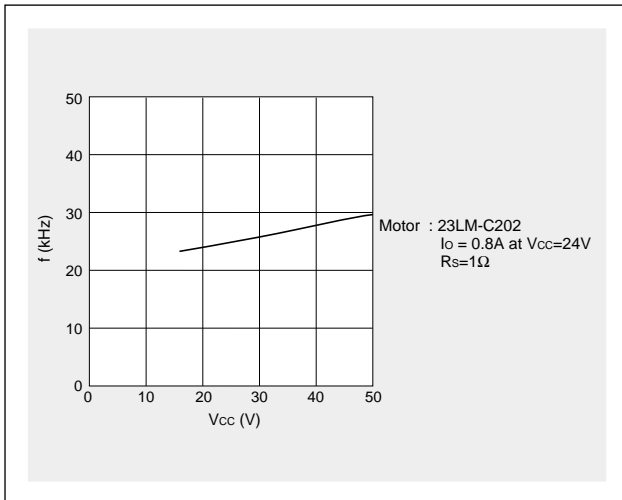

**Chopper frequency vs. Output current**

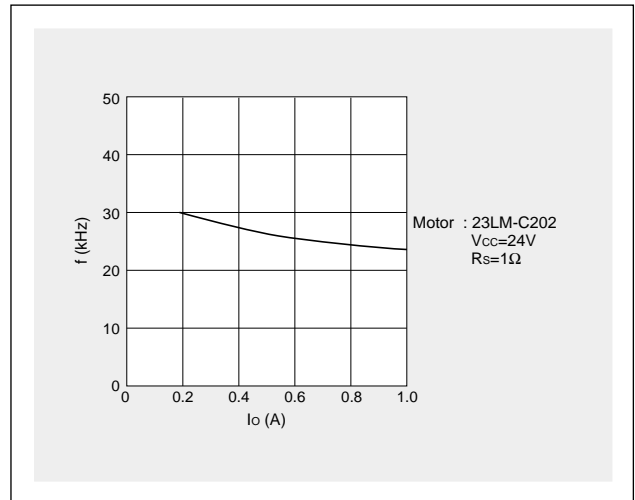

**Thermal Design**

An outline of the method for calculating heat dissipation is shown below.

(1) Obtain the value of  $P_H$  that corresponds to the motor coil current  $I_o$  from Fig. 7 "Heat dissipation per phase  $P_H$  vs. Output current  $I_o$ ."

(2) The power dissipation  $P_{diss}$  is obtained using the following formula.

2-phase excitation:  $P_{diss} \cong 2P_H + 0.015 \times V_s$  (W)

1-2 phase excitation:  $P_{diss} \cong \frac{3}{2} P_H + 0.015 \times V_s$  (W)

(3) Obtain the temperature rise that corresponds to the calculated value of  $P_{diss}$  from Fig. 8 "Temperature rise."

**Fig. 7 Heat dissipation per phase  $P_H$  vs. Output current  $I_o$**

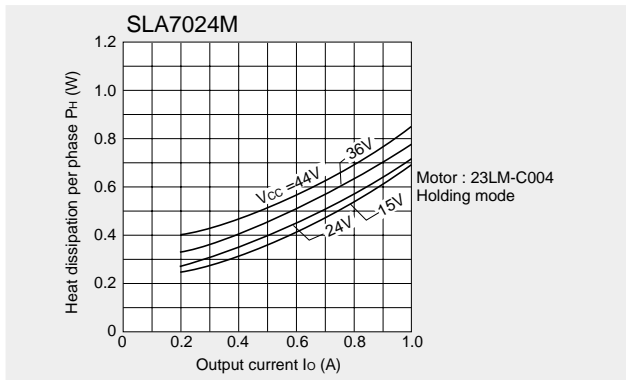
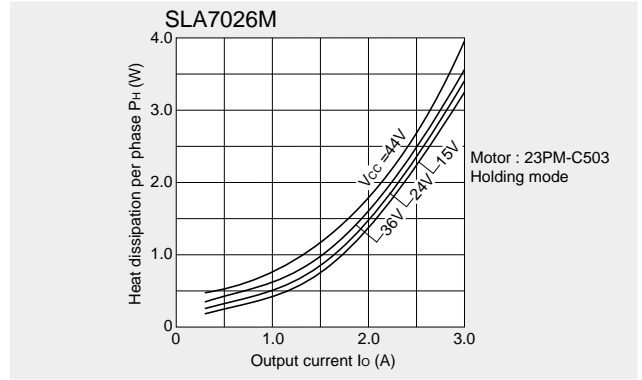
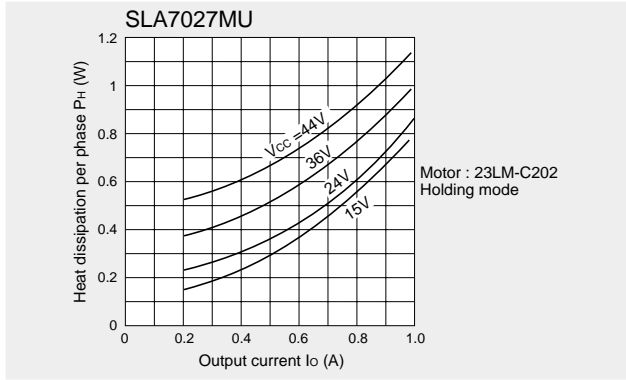

**Fig. 8 Temperature rise**

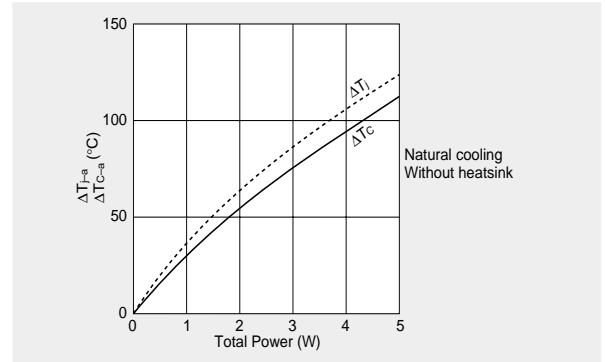

**Thermal characteristics**

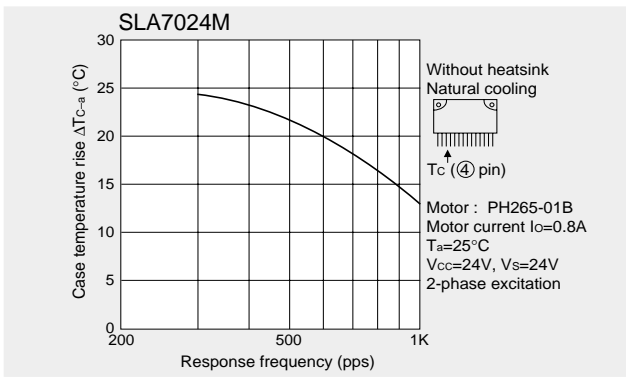
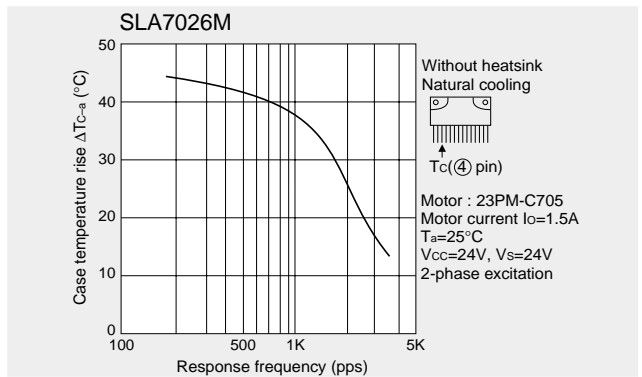
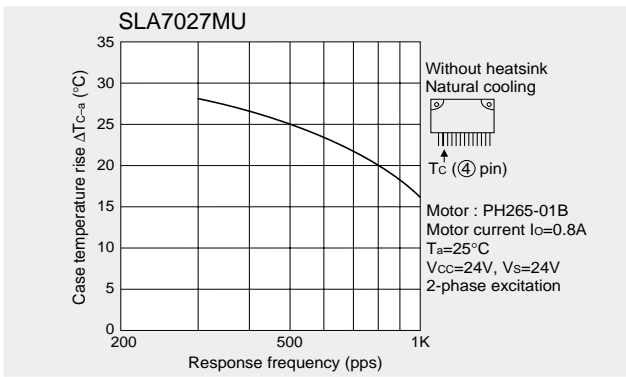

Supply Voltage  $V_{CC}$  vs. Supply Current  $I_{CC}$

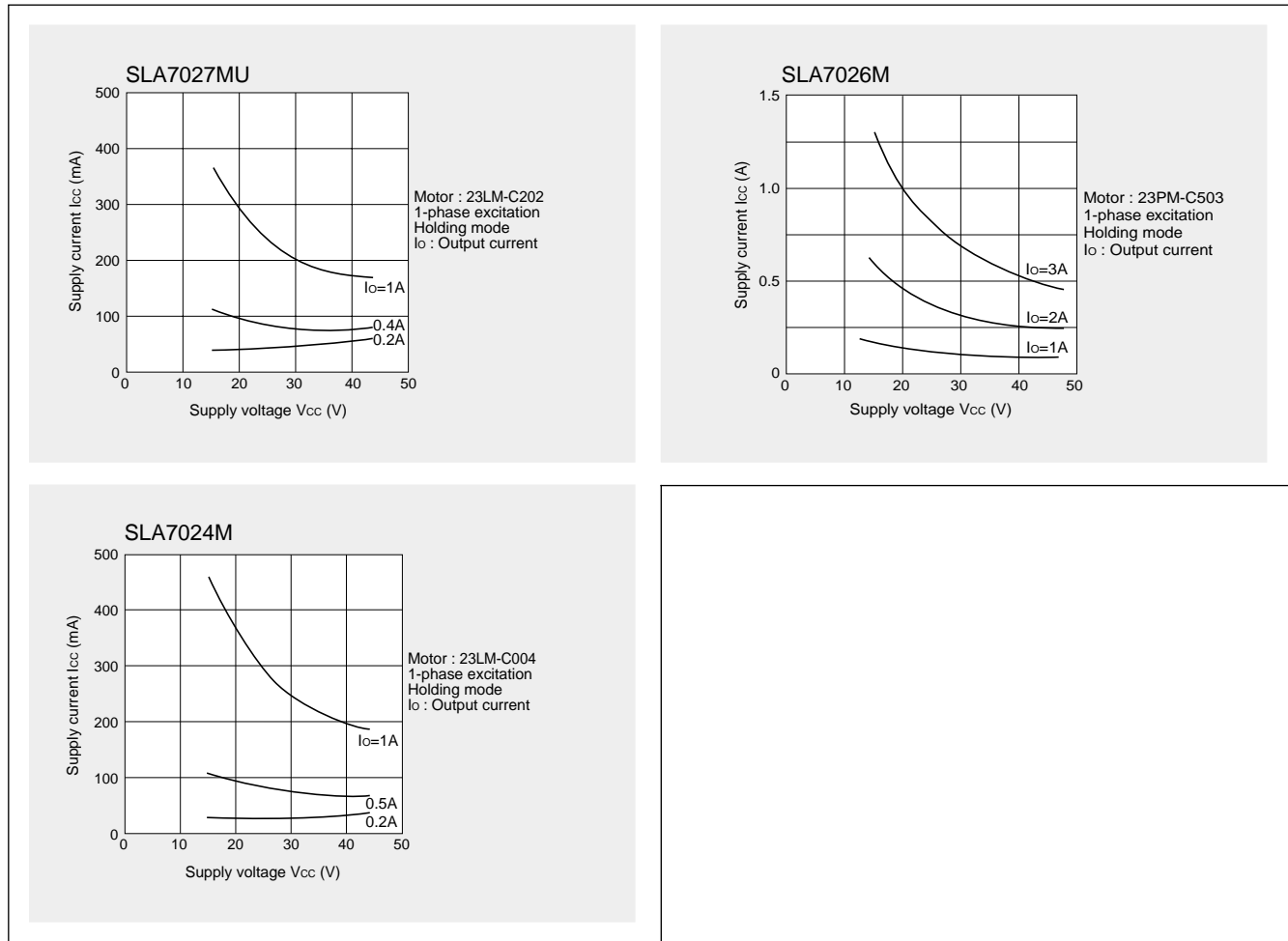

Note

The excitation input signals of the SLA7027MU, SLA7024M and SLA7026M can be used as either Active High or Active Low. Note, however, that the corresponding output (OUT) changes depending on the input (IN).

Active High

Input	Corresponding output
$IN_A$ (pin6)	$OUT_A$ (pin1)
$IN_{\bar{A}}$ (pin5)	$OUT_{\bar{A}}$ (pin8)
$IN_B$ (pin17)	$OUT_B$ (pin11)
$IN_{\bar{B}}$ (pin16)	$OUT_{\bar{B}}$ (pin18)

Active Low

Input	Corresponding output
$IN_A$ (pin6)	$OUT_{\bar{A}}$ (pin8)
$IN_{\bar{A}}$ (pin5)	$OUT_A$ (pin1)
$IN_B$ (pin17)	$OUT_{\bar{B}}$ (pin18)
$IN_{\bar{B}}$ (pin16)	$OUT_B$ (pin11)