

2-Phase Stepper Motor Unipolar Driver ICs

Absolute Maximum Ratings

(Ta=25°C)

Parameter	Symbol	Ratings				Units
		SLA7022MU	SLA7029M	SMA7022MU	SMA7029M	
Motor supply voltage	V _{CC}	46				V
FET Drain-Source voltage	V _{DSS}	100				V
Control supply voltage	V _S	46				V
TTL input voltage	V _{IN}	7				V
Reference voltage	V _{REF}	2				V
Output current	I _O	1	1.5	1	1.5	A
Power dissipation	P _{D1}	4.5 (Without Heatsink)		4.0 (Without Heatsink)		W
	P _{D2}	35 (T _C =25°C)		28(T _C =25°C)		W
Channel temperature	T _{ch}	+150				°C
Storage temperature	T _{stg}	-40 to +150				°C

Electrical Characteristics

(Ta=25°C)

Parameter	Symbol	Ratings												Units
		SLA7022MU			SLA7029M			SMA7022MU			SMA7029M			
		min	typ	max	min	typ	max	min	typ	max	min	typ	max	
Control supply current	I _S		10	15		10	15		10	15		10	15	mA
	Condition	V _S =44V			V _S =44V			V _S =44V			V _S =44V			
Control supply voltage	V _S	10	24	44	10	24	44	10	24	44	10	24	44	V
FET Drain-Source voltage	V _{DSS}	100			100			100			100			V
	Condition	V _S =44V, I _{DSS} =250 μA			V _S =44V, I _{DSS} =250 μA			V _S =44V, I _{DSS} =250 μA			V _S =44V, I _{DSS} =250 μA			
FET ON voltage	V _{DS}			0.85			0.6			0.85			0.6	V
	Condition	I _D =1A, V _S =14V			I _D =1A, V _S =14V			I _D =1A, V _S =14V			I _D =1A, V _S =14V			
FET drain leakage current	I _{DSS}			4			4			4			4	mA
	Condition	V _{DSS} =100V, V _S =44V			V _{DSS} =100V, V _S =44V			V _{DSS} =100V, V _S =44V			V _{DSS} =100V, V _S =44V			
FET diode forward voltage	V _{SD}			1.2			1.1			1.2			1.1	V
	Condition	I _D =1A			I _D =1A			I _D =1A			I _D =1A			
TTL input current	I _{IH}			40			40			40			40	μA
	Condition	V _{IH} =2.4V, V _S =44V			V _{IH} =2.4V, V _S =44V			V _{IH} =2.4V, V _S =44V			V _{IH} =2.4V, V _S =44V			
	I _{IL}			-0.8			-0.8			-0.8			-0.8	mA
	Condition	V _{IL} =0.4V, V _S =44V			V _{IL} =0.4V, V _S =44V			V _{IL} =0.4V, V _S =44V			V _{IL} =0.4V, V _S =44V			
TTL input voltage (Active High)	V _{IH}	2			2			2			2			V
	Condition	I _D =1A			I _D =1A			I _D =1A			I _D =1A			
	V _{IL}			0.8			0.8			0.8			0.8	
	Condition	V _{DSS} =100V			V _{DSS} =100V			V _{DSS} =100V			V _{DSS} =100V			
TTL input voltage (Active Low)	V _{IH}	2			2			2			2			V
	Condition	V _{DSS} =100V			V _{DSS} =100V			V _{DSS} =100V			V _{DSS} =100V			
	V _{IL}			0.8			0.8			0.8			0.8	
	Condition	I _D =1A			I _D =1A			I _D =1A			I _D =1A			
Switching time	T _r		0.5			0.5			0.5			0.5		μs
	Condition	V _S =24V, I _D =0.8A			V _S =24V, I _D =1A			V _S =24V, I _D =0.8A			V _S =24V, I _D =1A			
	T _{stg}		0.7			0.7			0.7			0.7		
	Condition	V _S =24V, I _D =0.8A			V _S =24V, I _D =1A			V _S =24V, I _D =0.8A			V _S =24V, I _D =1A			
	T _f		0.1			0.1			0.1			0.1		
Condition	V _S =24V, I _D =0.8A			V _S =24V, I _D =1A			V _S =24V, I _D =0.8A			V _S =24V, I _D =1A				

Internal Block Diagram

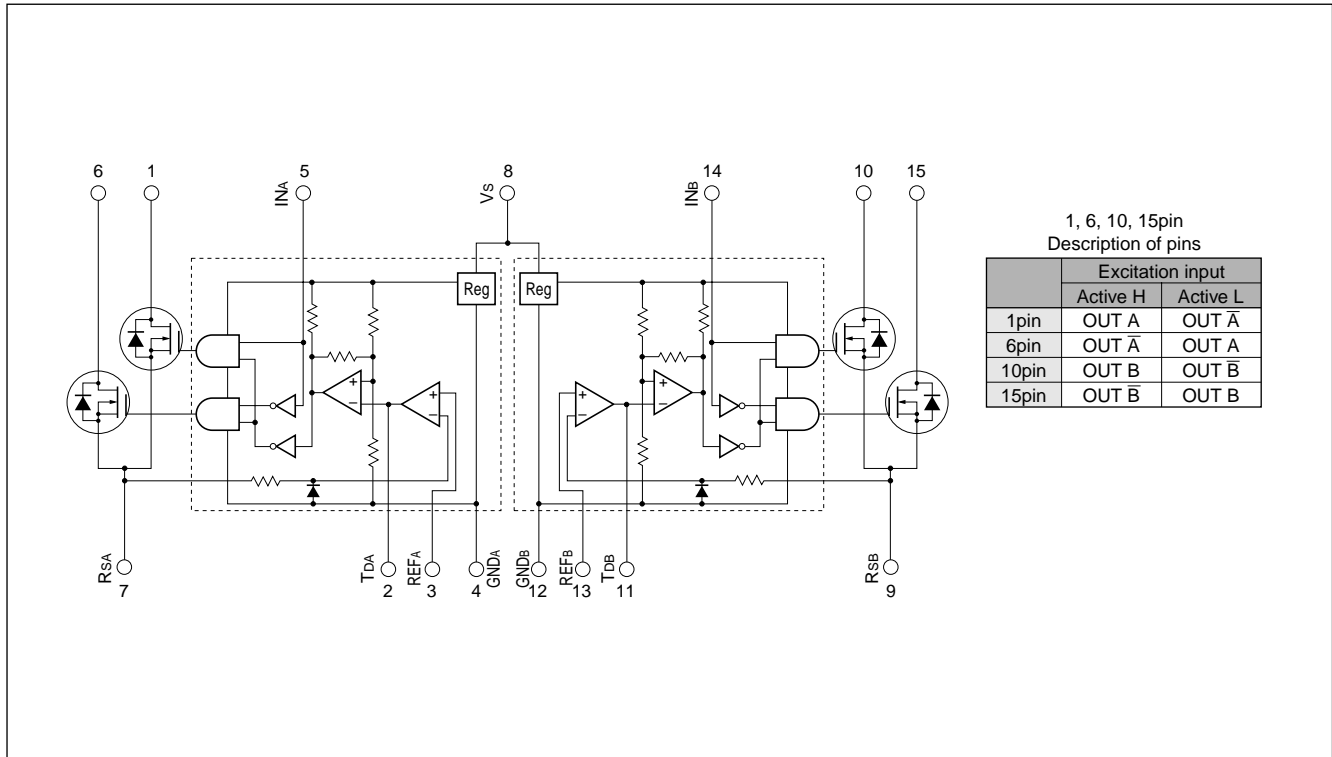
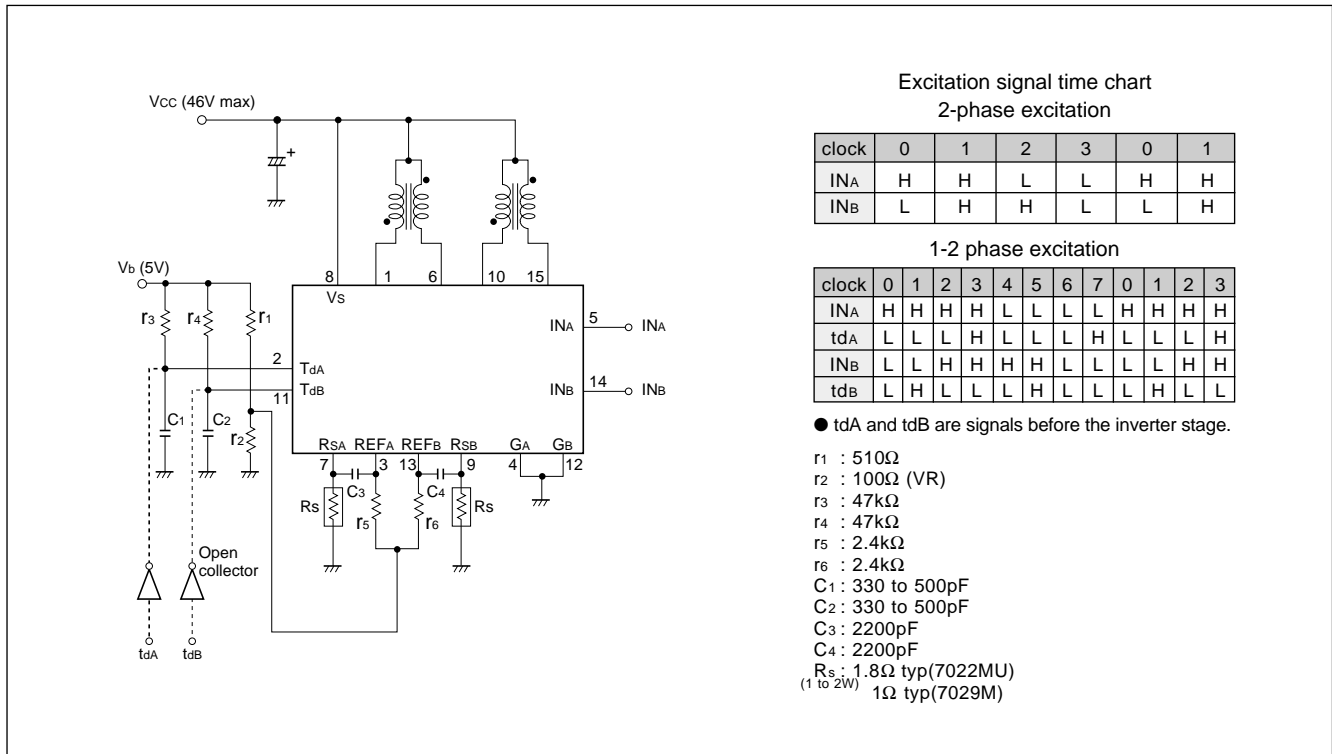
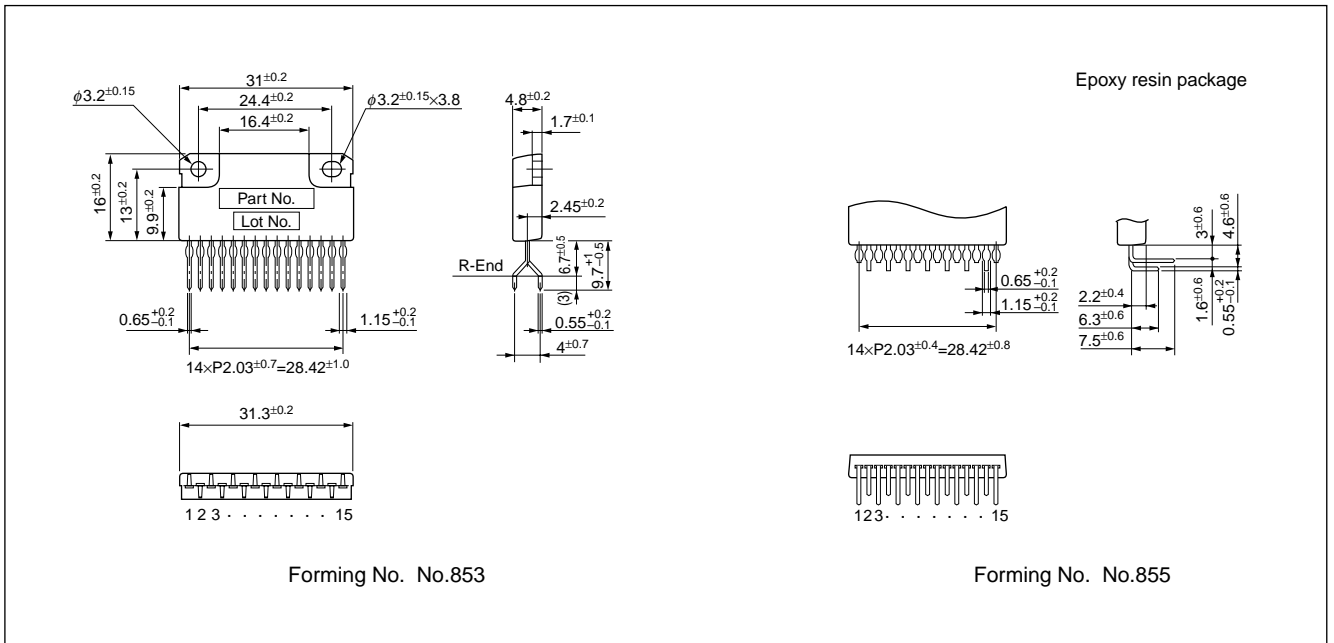

Diagram of Standard External Circuit (Recommended Circuit Constants)



External Dimensions SLA7022MU/SLA7029M

(Unit: mm)



External Dimensions SMA7022MU/SMA7029MA

(Unit: mm)

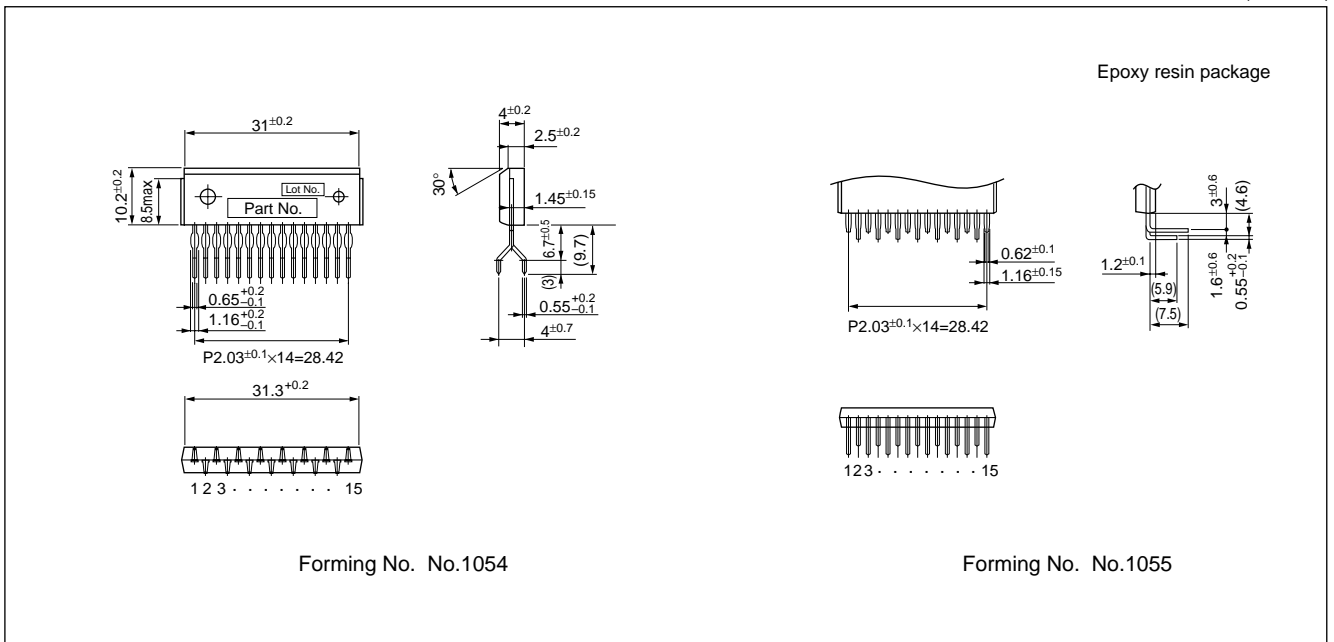

Application Notes

Determining the Output Current

Fig. 1 shows the waveform of the output current (motor coil current). The method of determining the peak value of the output current (I_o) based on this waveform is shown below.

(Parameters for determining the output current I_o)

V_b : Reference supply voltage

r_1, r_2 : Voltage-divider resistors for the reference supply voltage

R_s : Current sense resistor

(1) Normal rotation mode

I_o is determined as follows when current flows at the maximum level during motor rotation. (See Fig.2.)

$$I_o \cong \frac{r_2}{r_1+r_2} \cdot \frac{V_b}{R_s} \dots\dots\dots (1)$$

(2) Power down mode

The circuit in Fig.3 (r_x and T_r) is added in order to decrease the coil current. I_o is then determined as follows.

$$I_{OPD} \cong \frac{1}{1 + \frac{r_1(r_2+r_x)}{r_2 \cdot r_x}} \cdot \frac{V_b}{R_s} \dots\dots\dots (2)$$

Equation (2) can be modified to obtain equation to determine r_x .

$$r_x = \frac{1}{\frac{1}{r_1} \left(\frac{V_b}{R_s \cdot I_{OPD}} - 1 \right) - \frac{1}{r_2}}$$

Fig. 4 and 5 show the graphs of equations (1) and (2) respectively.

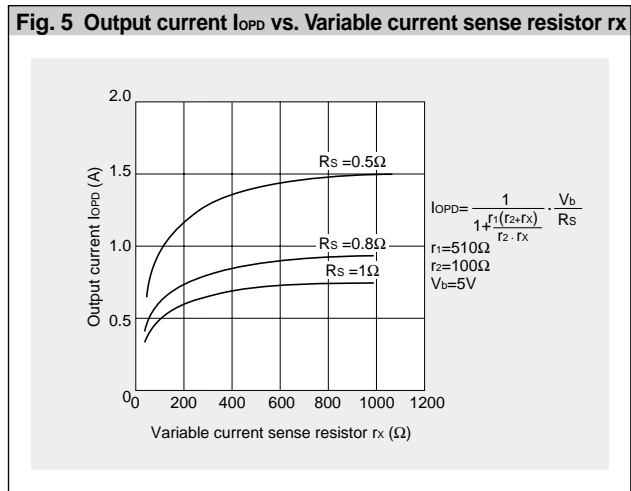
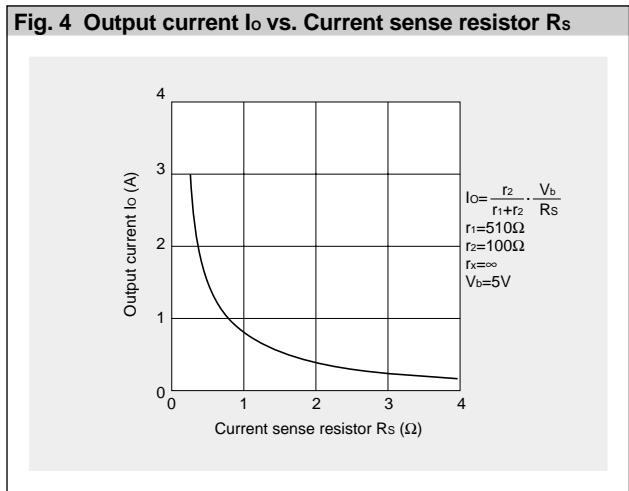
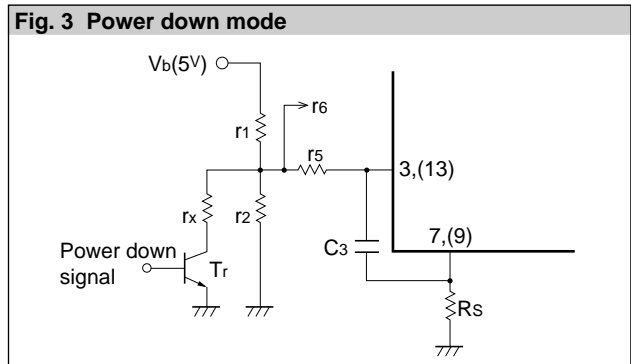
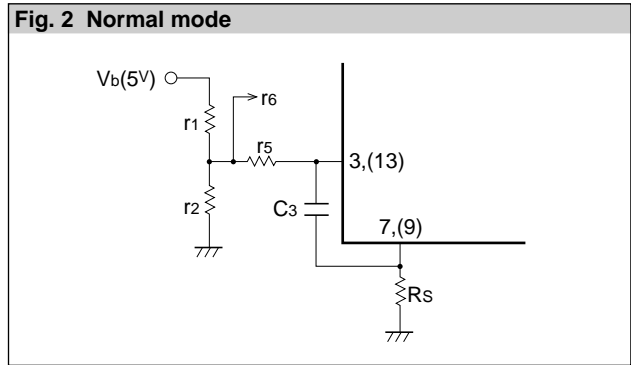
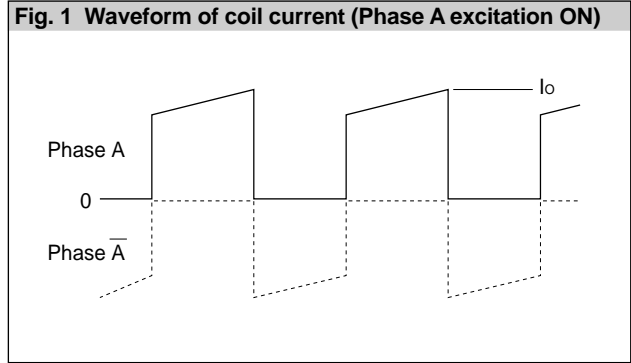

(NOTE)

Ringing noise is produced in the current sense resistor R_s when the MOSFET is switched ON and OFF by chopping. This noise is also generated in feedback signals from R_s which may therefore cause the comparator to malfunction. To prevent chopping malfunctions, $r_5(r_6)$ and $C_3(C_4)$ are added to act as a noise filter.

However, when the values of these constants are increased, the response from R_s to the comparator becomes slow. Hence the value of the output current I_o is somewhat higher than the calculated value.

Determining the chopper frequency

Determining T_{OFF}

The SLA7000M and SMA7000M series are self-excited choppers. The chopping OFF time T_{OFF} is fixed by r_3/C_1 and r_4/C_2 connected to terminal Td.

T_{OFF} can be calculated using the following formula:

$$T_{OFF} \approx -r_3 \cdot C_1 \ln\left(1 - \frac{2}{V_b}\right) \approx -r_4 \cdot C_2 \ln\left(1 - \frac{2}{V_b}\right)$$

The circuit constants and the T_{OFF} value shown below are recommended.

$T_{OFF} = 12\mu s$ at $r_3=47k\Omega$, $C_1=500pF$, $V_b=5V$

Fig. 6 Chopper frequency vs. Motor coil resistance

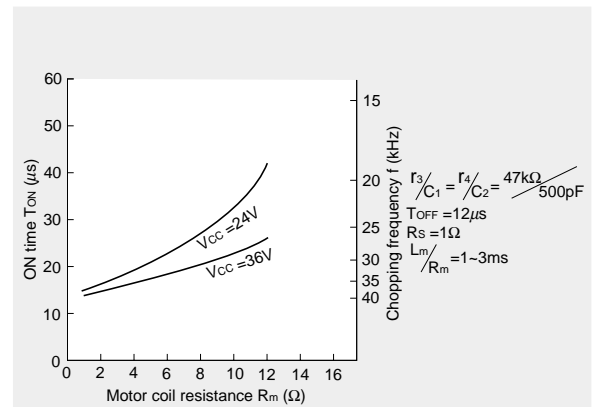

Chopper frequency vs. Supply voltage

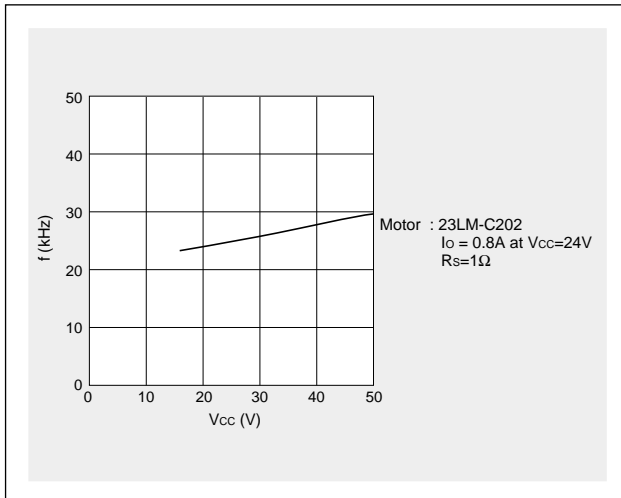

Chopper frequency vs. Output current

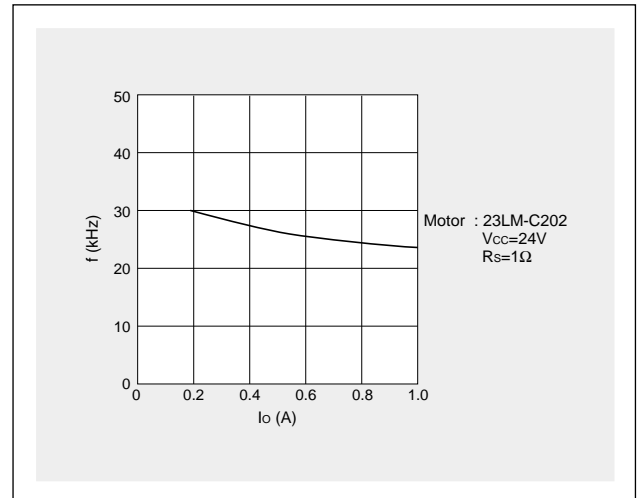

Thermal Design

An outline of the method for calculating heat dissipation is shown below.

- (1) Obtain the value of P_H that corresponds to the motor coil current I_o from Fig. 7 "Heat dissipation per phase P_H vs. Output current I_o ."

- (2) The power dissipation P_{diss} is obtained using the following formula.

2-phase excitation: $P_{diss} \cong 2P_H + 0.015 \times V_s$ (W)

1-2 phase excitation: $P_{diss} \cong \frac{3}{2} P_H + 0.015 \times V_s$ (W)

- (3) Obtain the temperature rise that corresponds to the calculated value of P_{diss} from Fig. 8 "Temperature rise."

Fig. 7 Heat dissipation per phase P_H vs. Output current I_o

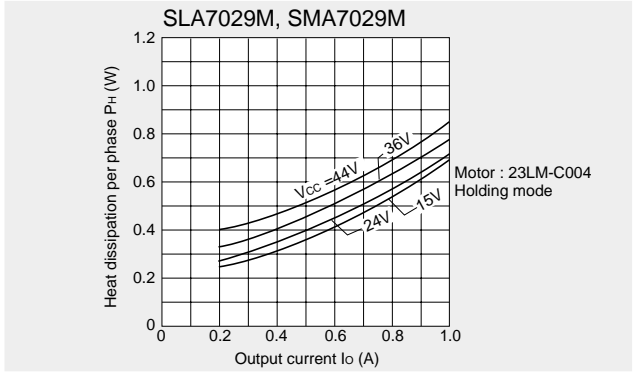
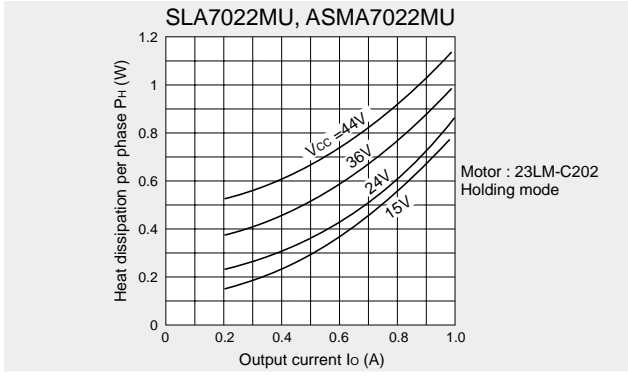
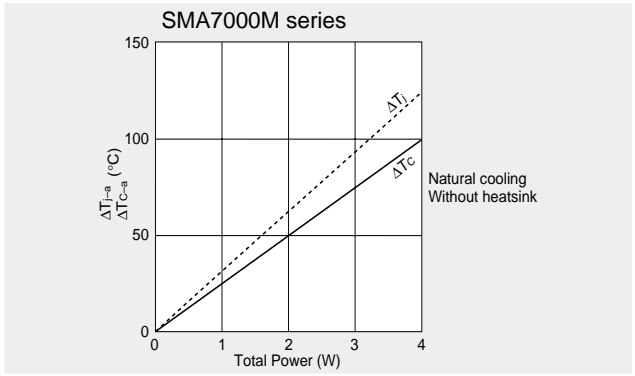
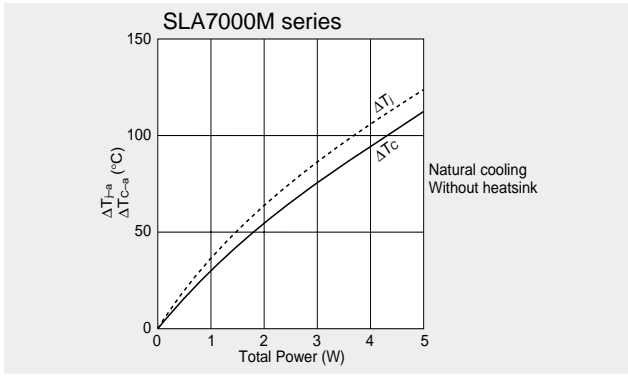
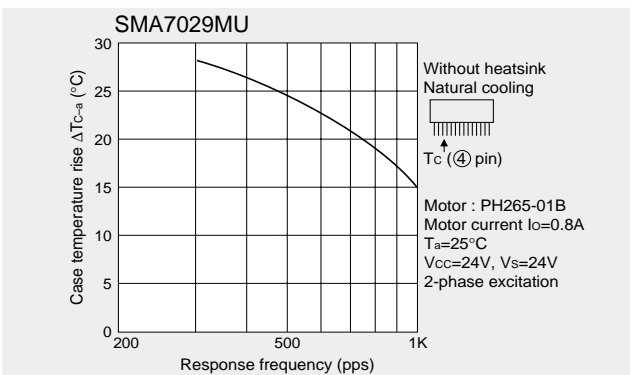
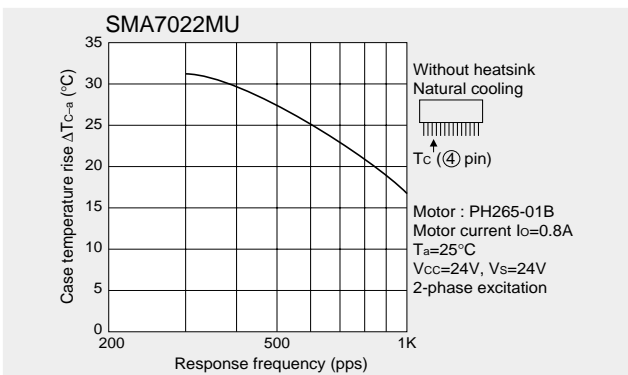
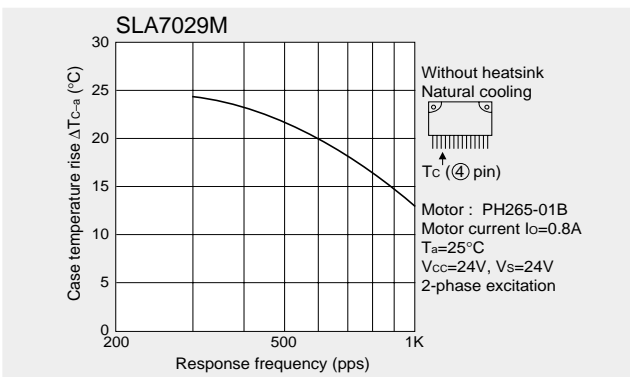
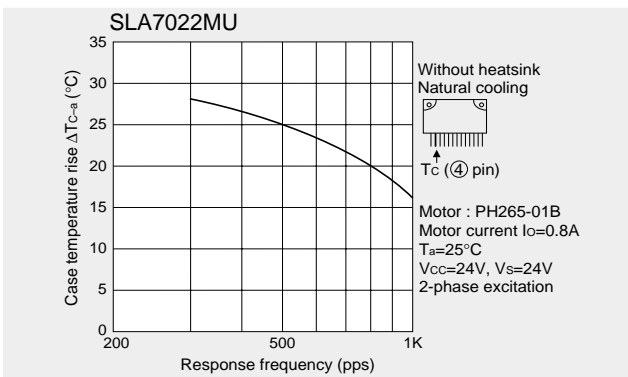

Fig. 8 Temperature rise



Thermal characteristics



■ Supply Voltage V_{CC} vs. Supply Current I_{CC}

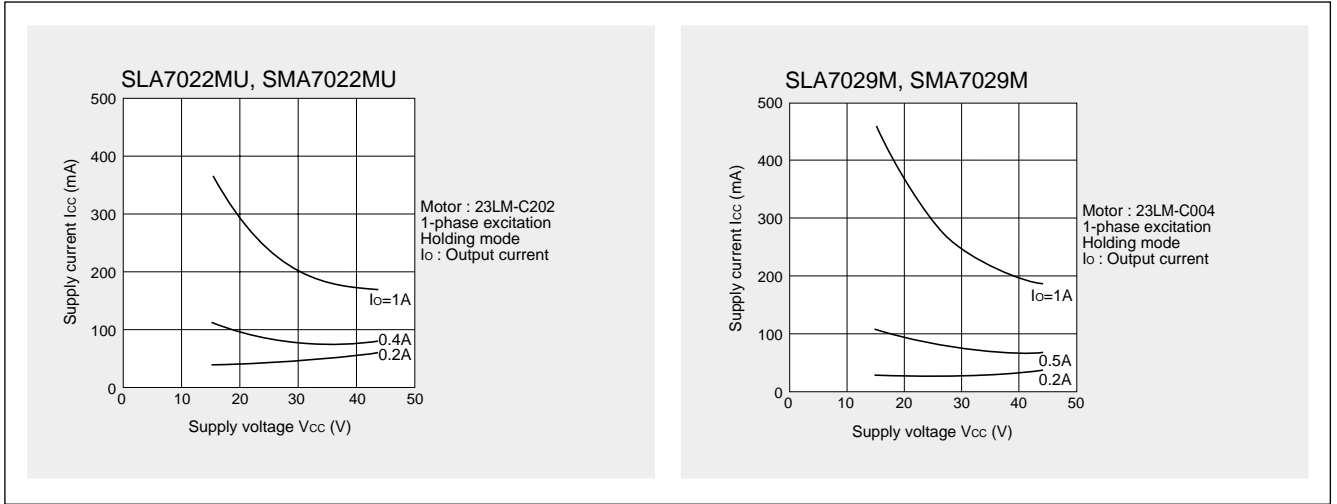

■ Torque Characteristics

