

TRANSISTOR MODULE (Hi-β)

QCA300BA60



UL;E76102 (M)

QCA300BA60 is a dual Darlington power transistor module which has series-connected **ULTRA HIGH** h_{FE} , high speed, high power Darlington transistor. Each transistor has a reverse paralleled fast recovery diode (trr : 200ns). The mounting base of the module is electrically isolated from semiconductor elements for simple heatsink construction,

- $I_C=300A$, $V_{CEX}=600V$
- Low saturation voltage for higher efficiency.
- ULTRA HIGH DC current gain h_{FE} . $h_{FE} \geq 750$
- Isolated mounting base
- V_{EBO} 10V for faster switching speed.

(Applications)

Motor Control (VVF), AC/DC Servo, UPS, Switching Power Supply, Ultrasonic Application

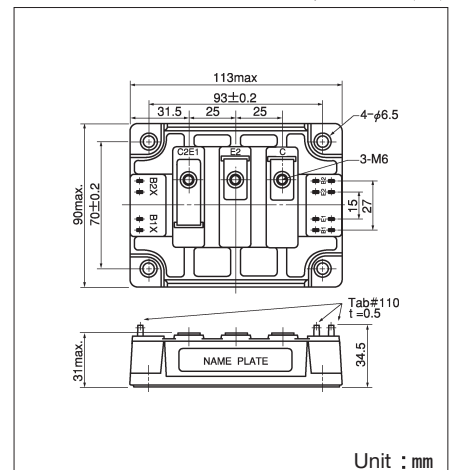
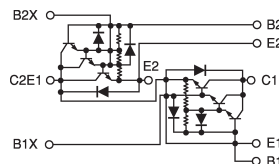

Unit : mm

Maximum Ratings

($T_j=25^\circ C$)

Symbol	Item	Conditions	Ratings		
			QCA300BA60	Unit	
V_{CBO}	Collector-Base Voltage		600	V	
V_{CEX}	Collector-Emitter Voltage	$V_{BE} = -2V$	600	V	
$V_{CEX(sus)}$	Collector-Emitter sustaining voltage	$I_C=60V$ $I_{B2} = -5A$	600	V	
V_{EBO}	Emitter-Base Voltage		10	V	
I_C	Collector Current	() =pw \leq 1ms	300 (600)	A	
$-I_C$	Reverse Collector Current		300	A	
I_B	Base Current		18	A	
P_T	Total power dissipation	$T_C=25^\circ C$	1380	W	
T_j	Junction Temperature		-40~+150	$^\circ C$	
T_{stg}	Storage Temperature		-40~+125	$^\circ C$	
V_{iso}	Isolation Voltage	A.C.1minute	2500	V	
	Mounting Torque	Mounting (M6)	Recommended Value 2.5~3.9 (25~40)	4.7 (48)	N·m (kgf·cm)
		Terminal (M6)	Recommended Value 2.5~3.9 (25~40)	4.7 (48)	
	Mass	Typical Value	675	g	

Electrical Characteristics

($T_j=25^\circ C$)

Symbol	Item	Conditions	Ratings			Unit
			Min.	Typ.	Max.	
I_{CBO}	Collector Cut-off Current	$V_{CB} = V_{CBO}$			4.0	mA
I_{EBO}	Emitter Cut-off Current	$V_{EB} = V_{EBO}$			500	mA
h_{FE}	D.C. Current Gain	$I_C=300A$, $V_{CE}=2.5V$	750			
$V_{CE(sat)}$	Collector-Emitter Saturation Voltage	$I_C=300A$, $I_B=400mA$			2.5	V
$V_{BE(sat)}$	Base-Emitter Saturation Voltage	$I_C=300A$, $I_B=400mA$			3.0	V
t_{on}	Switching Time	On Time			2.0	μs
t_s		Storage Time	$V_{CC}=300V$, $I_C=300A$ $I_{B1}=0.6A$, $I_{B2}=-6A$		8.0	
t_f		Fall Time			2.0	
V_{ECO}	Collector-Emitter Reverse Voltage	$I_C = -300A$			2.2	V
trr	Reverse Recovery time	$V_{CC}=300V$, $I_C = -300A$, $-di/dt=300A/\mu s$, $V_{BE} = -5V$		200		ns
$R_{th(j-c)}$	Thermal Impedance (junction to case)	Transistor part			0.08	$^\circ C/W$
		Diode part			0.35	

