

CMOS 8-bit Single Chip Microcomputer

**Piggyback/
evaluator type**

Description

The CXP81900 is a CMOS 8-bit single chip micro-computer of piggyback/evaluator combined type, which is developed for evaluating the function of the CXP81952/81960.

Features

- A wide instruction set (213 instructions) which cover various types of data.
 - 16-bit operation/multiplication and division/boolean bit operation instructions
- Minimum instruction cycle 250ns at 16MHz operation (4.5 to 5.5V)
 333ns at 12MHz operation (3.0 to 5.5V)
 122µs at 32kHz operation
- Applicable EPROM LCC type 27C256, LCC type 27C512
 (Maximum 60Kbytes are available.)
- Incorporated RAM capacity 2048 bytes
- Peripheral functions
 - A/D converter 8-bit, 12-channel, successive approximation method
 (Conversion time of 20µs/16MHz)
 - Serial interface Incorporated buffer RAM
 (Auto transfer for 1 to 32 bytes), 1 channel
 Incorporated 8-bit and 8-stage FIFO
 (Auto transfer for 1 to 8 bytes), 1 channel
 - Timer 8-bit timer, 8-bit timer/counter
 19-bit time base timer
 32kHz timer/counter
 - High precision timing pattern generator PPG 19-pin, 32-stage programmable
 RTG 5 pins, 2 channels
 - PWM/DA gate output PWM output 12 bits, 2 channels
 (Repetitive frequency 62.5kHz/16MHz)
 DA gate pulse output 13 bits, 4channels
 - FRC capture unit Incorporated 26-bit and 8-stage FIFO
 - PWM output 14 bits, 1 channel
 - Remote control receiving circuit 8-bit pulse measurement counter with on-chip 6-stage FIFO
 - General purpose prescaler 7 bits (PG5 input frequency division, FRC capture possible.)
 - HSYNC counter 12-bit event counter (SYNC1 input count)
- Interruption 20 factors, 15 vectors, multi-interruption possible
- Standby mode SLEEP/STOP
- Package 100-pin ceramic PQFP

Note) Mask option depends on the type of the CXP81900. Refer to the Products List for details.

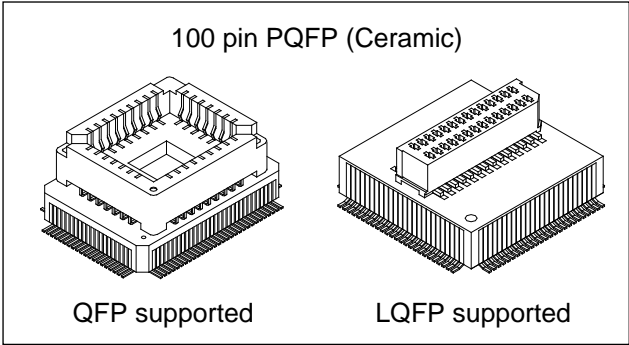

Structure

Silicon gate CMOS IC

Sony reserves the right to change products and specifications without prior notice. This information does not convey any license by any implication or otherwise under any patents or other right. Application circuits shown, if any, are typical examples illustrating the operation of the devices. Sony cannot assume responsibility for any problems arising out of the use of these circuits.

Pin Assignment in Piggyback Mode (LQFP package)

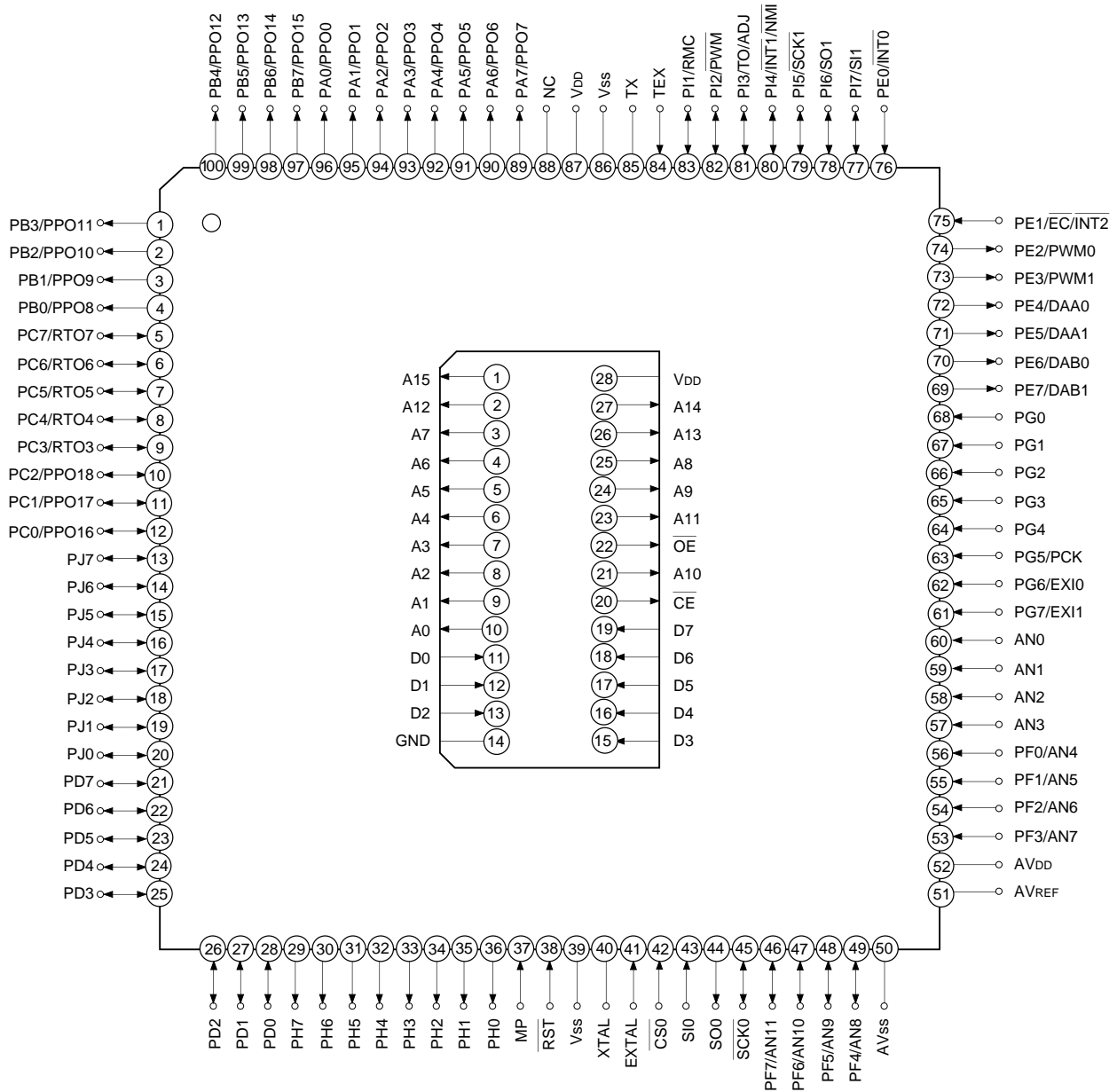

- Note)**
1. NC (Pin 88) is always connected to V_{DD}.
 2. V_{SS} (Pins 39 and 86) are both connected to GND.
 3. MP (Pin 37) is always connected to GND.

Pin Assignment in Evaluator Mode (QFP package)

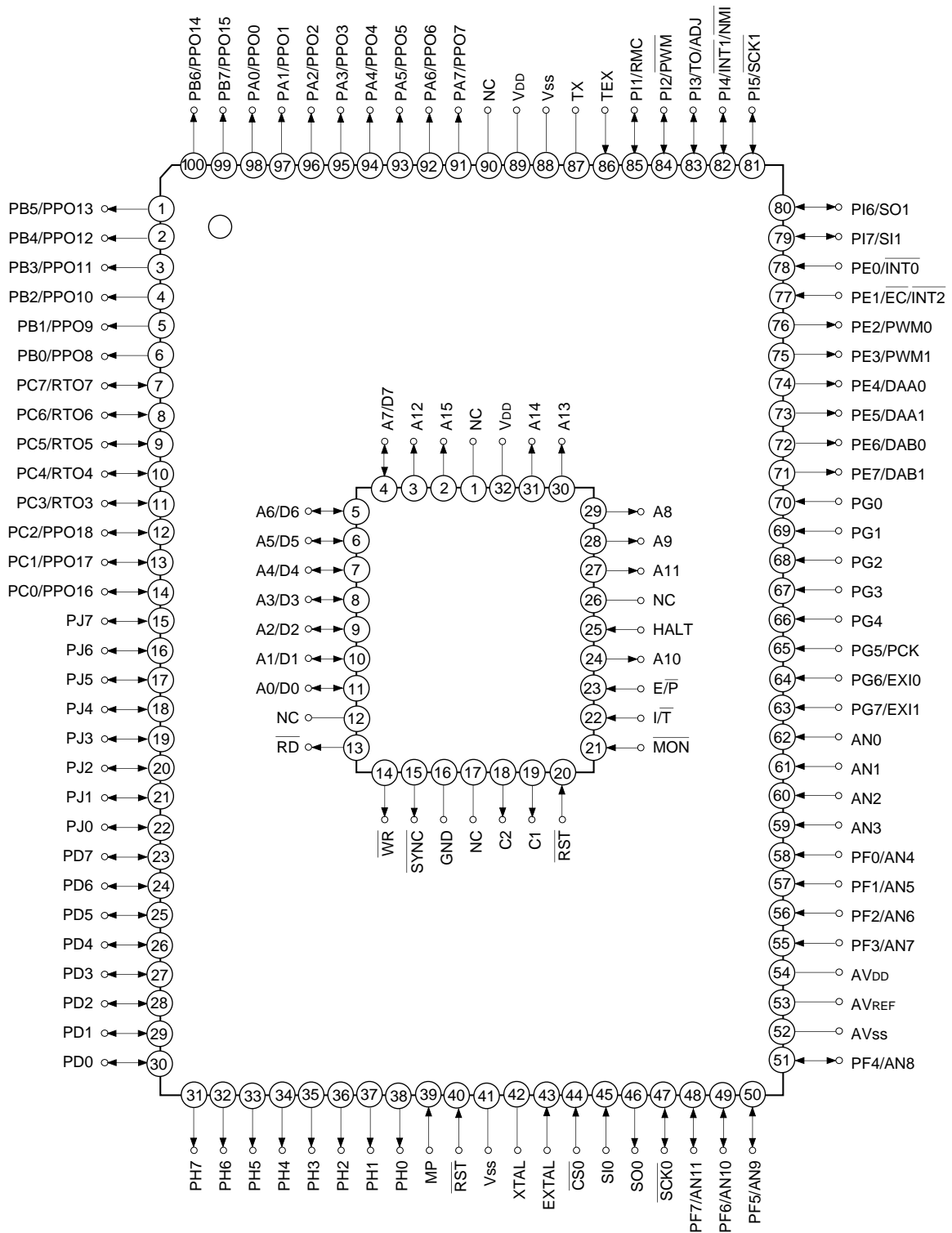

- Note)**
1. NC (Pin 90) is always connected to V_{DD}.
 2. V_{SS} (Pins 41 and 88) are both connected to GND.
 3. MP (Pin 39) is always connected to GND.

Pin Assignment in Evaluator Mode (LQFP package)

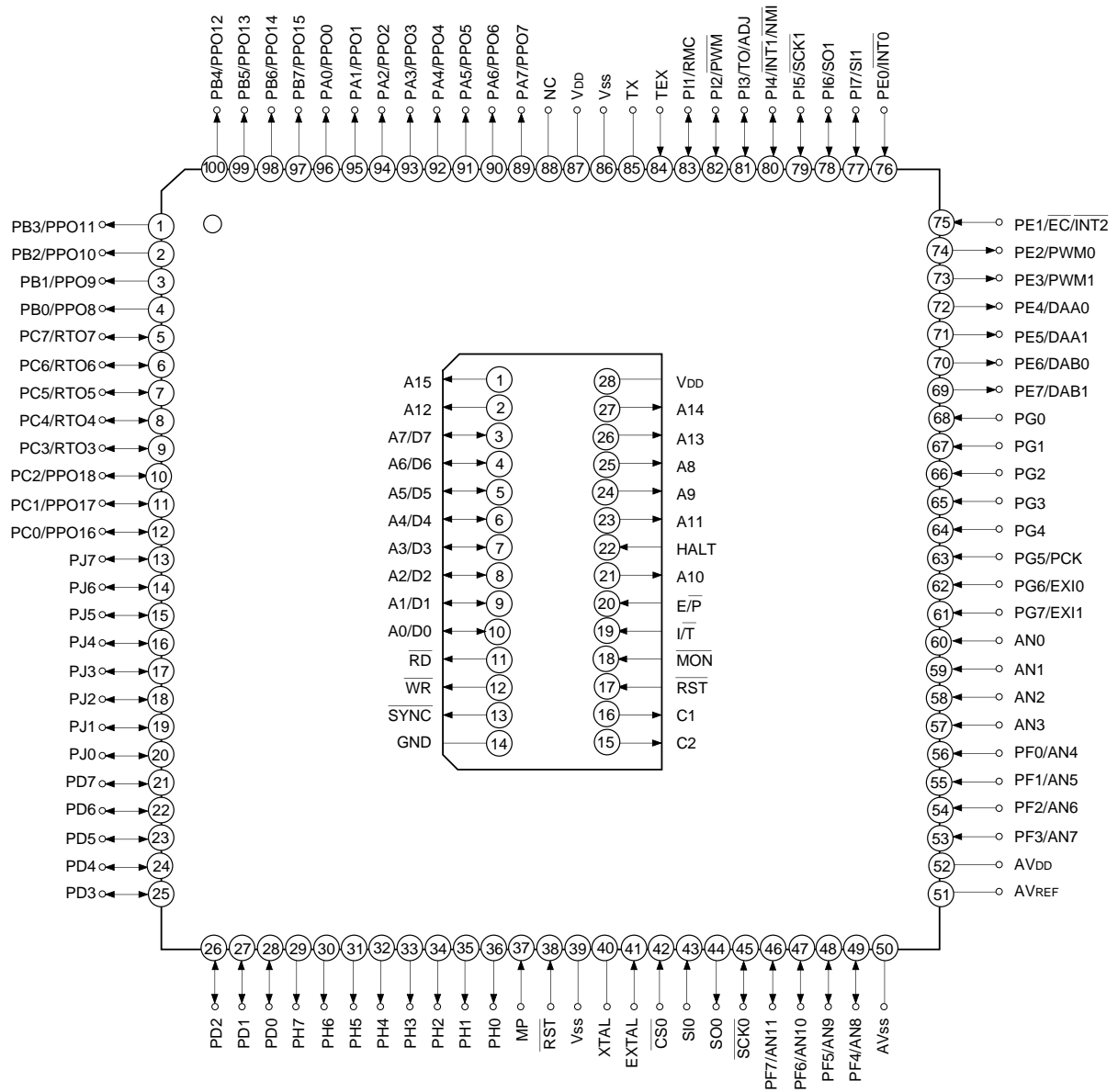

- Note)**
1. NC (Pin 88) is always connected to VDD.
 2. Vss (Pins 39 and 86) are both connected to GND.
 3. MP (Pin 37) is always connected to GND.

EPROM Read Timing ($T_a = -20$ to $+75^\circ\text{C}$, $V_{DD} = 3.0$ to 5.5V , $V_{SS} = 0\text{V}$)

Item	Symbol	Pin	Min.	Max.	Unit
Address → data input delay time	t_{ACC}	A0 to A15 D0 to D7		100*1	ns
				75*2	
Address → data hold time	t_{IH}	A0 to A15 D0 to D7	0		ns

*1 At 12MHz operation ($V_{DD} = 4.5$ to 5.5V)

*2 At 12MHz operation ($V_{DD} = 3.0$ to 5.5V), At 16MHz operation ($V_{DD} = 4.5$ to 5.5V)

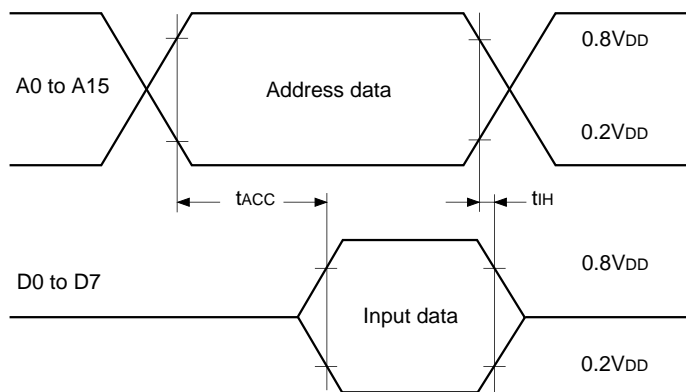

Products List

Option item	Products				
	Mask product		Piggyback/evaluator product		
	CXP81952	CXP81960	CXP81900-U03Q CXP81900-U03R	CXP81900-U04Q CXP81900-U04R	CXP81900-U06R
Package	100-pin plastic QFP/LQFP		100-pin ceramic PQFP		
ROM capacity	52Kbytes	60Kbytes	EPROM 60Kbytes		
			$27\text{C}512 \times 1$	$27\text{C}512 \times 1$	$27\text{C}256 \times 2$
Pull-up resistor for reset pin	Existent/Non-existent		Existent		
Supply voltage	3.0 to 5.5V		4.5 to 5.5V	3.0 to 5.5V	3.0 to 5.5V

Piggyback mode/evaluator mode can be switched as shown below.

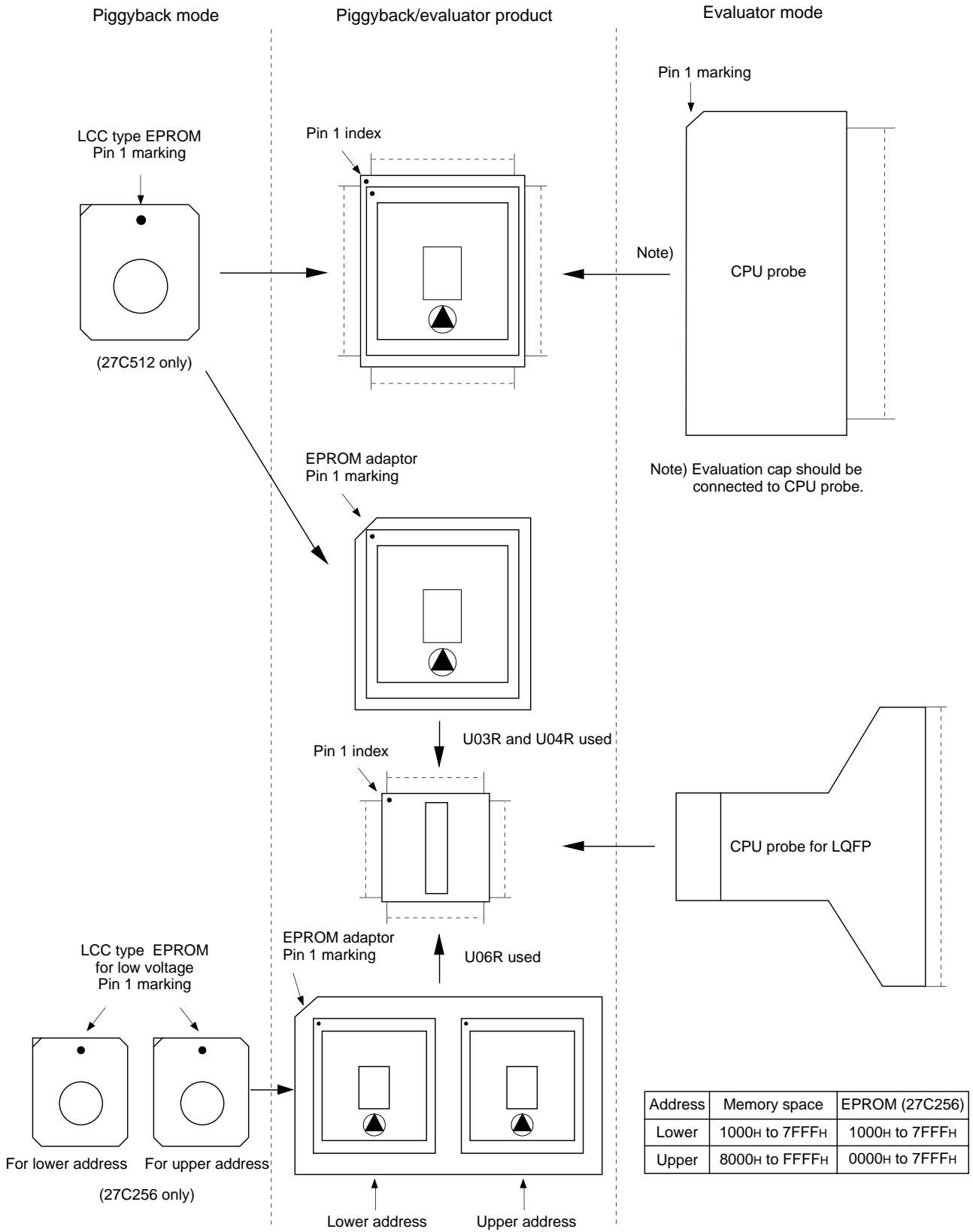

Package Outline Unit: mm

100PIN PQFP (CERAMIC)

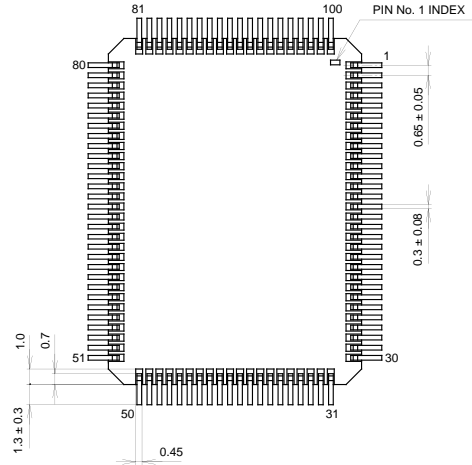
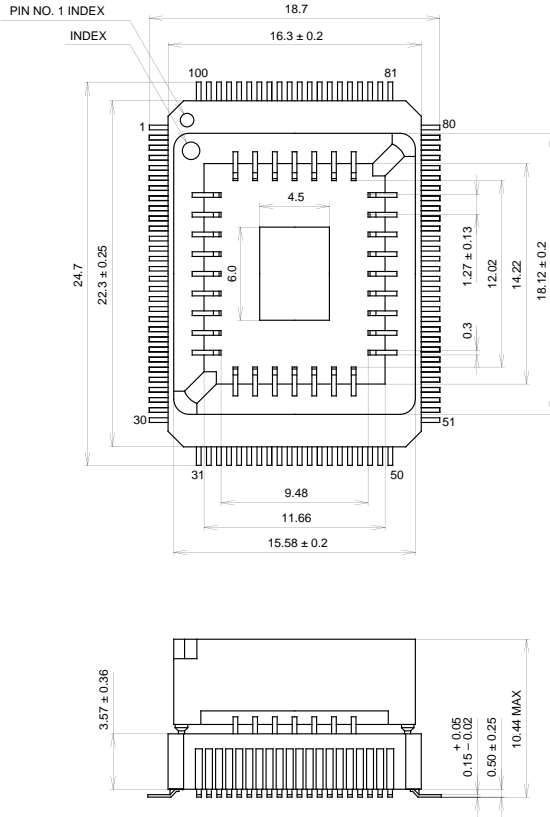

PACKAGE STRUCTURE

SONY CODE	PQFP-100C-L01
EIAJ CODE	AQFP100-C-0000-A
JEDEC CODE	

PACKAGE MATERIAL	CERAMIC
LEAD TREATMENT	GOLD PLATING
LEAD MATERIAL	42 ALLOY
PACKAGE WEIGHT	5.7g

100PIN PQFP (CERAMIC)

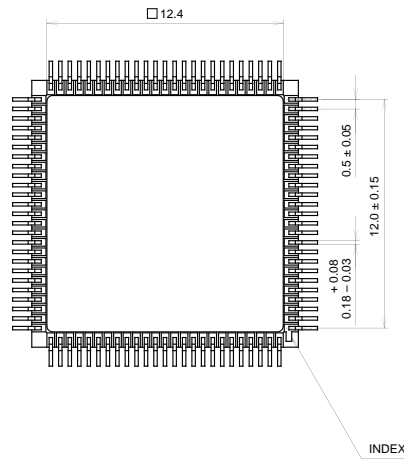
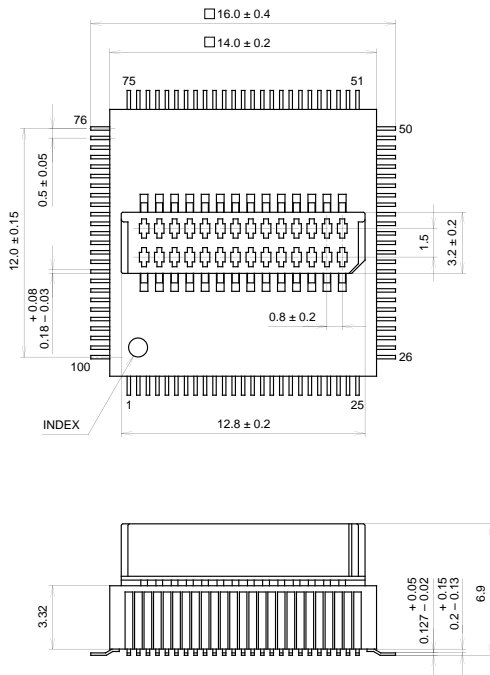

PACKAGE STRUCTURE

SONY CODE	PQFP-100C-L02
EIAJ CODE	AQFP100-C-1414-A
JEDEC CODE	

PACKAGE MATERIAL	CERAMIC
LEAD TREATMENT	GOLD PLATING
LEAD MATERIAL	42 ALLOY
PACKAGE WEIGHT	2.2g