

US Audio Multiplexing Decoder

Description

The CXA2134Q is an IC designed as a decoder for the Zenith TV Multi-channel System and also corresponds with I²C bus. Functions include stereo demodulation, SAP (Separate Audio Program) demodulation, dbx noise reduction and sound processor. Various kinds of filters are built in this IC. Adjustment, mode control and sound processor control are all executed through I²C bus.

Features

- Alignment-free VCO and filter
 - Audio multiplexing decoder
 - dbx noise reduction decoder
 - sound processor
 - Two external inputs
 - Quasi-surround
 - Bass control
 - Treble control
 - Volume control
- are all included in a single chip. Almost any sort of signal processing is possible through this IC.
- Input level, separation adjustments and each mode control are possible through I²C bus.

48 pin QFP (Plastic)

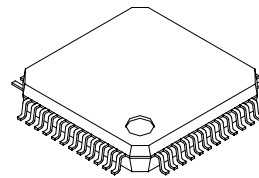

Applications

TV, VCR and other decoding systems for US audio multiplexing TV broadcasting

Structure

Bipolar silicon monolithic IC

Absolute Maximum Ratings (Ta = 25°C)

• Supply voltage	V _{CC}	11	V
• Operating temperature	T _{opr}	-20 to +75	°C
• Storage temperature	T _{stg}	-65 to +150	°C
• Allowable power dissipation	P _D	0.6	W

Range of Operating Supply Voltage

	9 ± 0.5	V
--	---------	---

* A license of the dbx-TV noise reduction system is required for the use of this device.

Sony reserves the right to change products and specifications without prior notice. This information does not convey any license by any implication or otherwise under any patents or other right. Application circuits shown, if any, are typical examples illustrating the operation of the devices. Sony cannot assume responsibility for any problems arising out of the use of these circuits.

Block Diagram

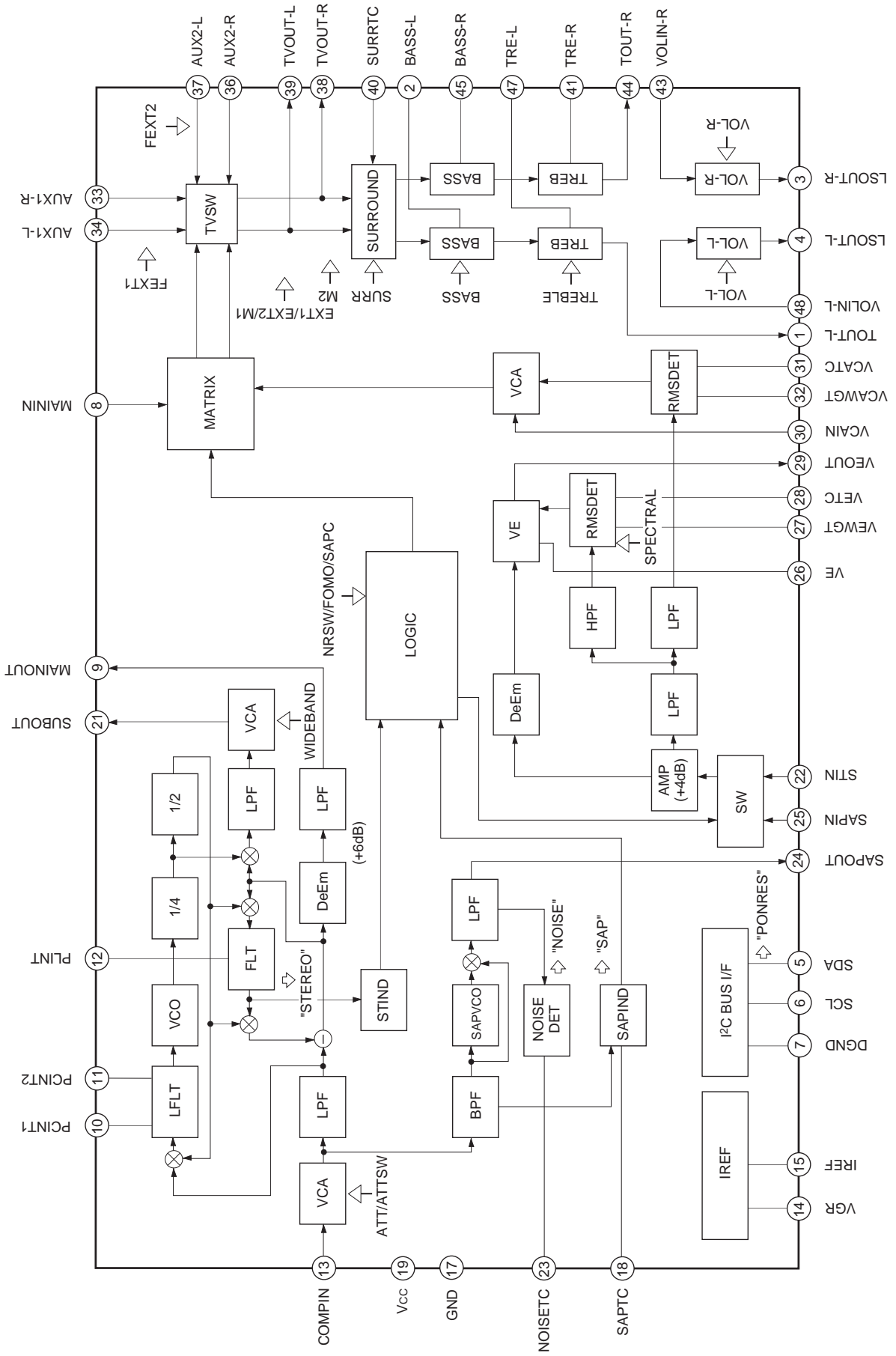

Pin Configuration (Top View)

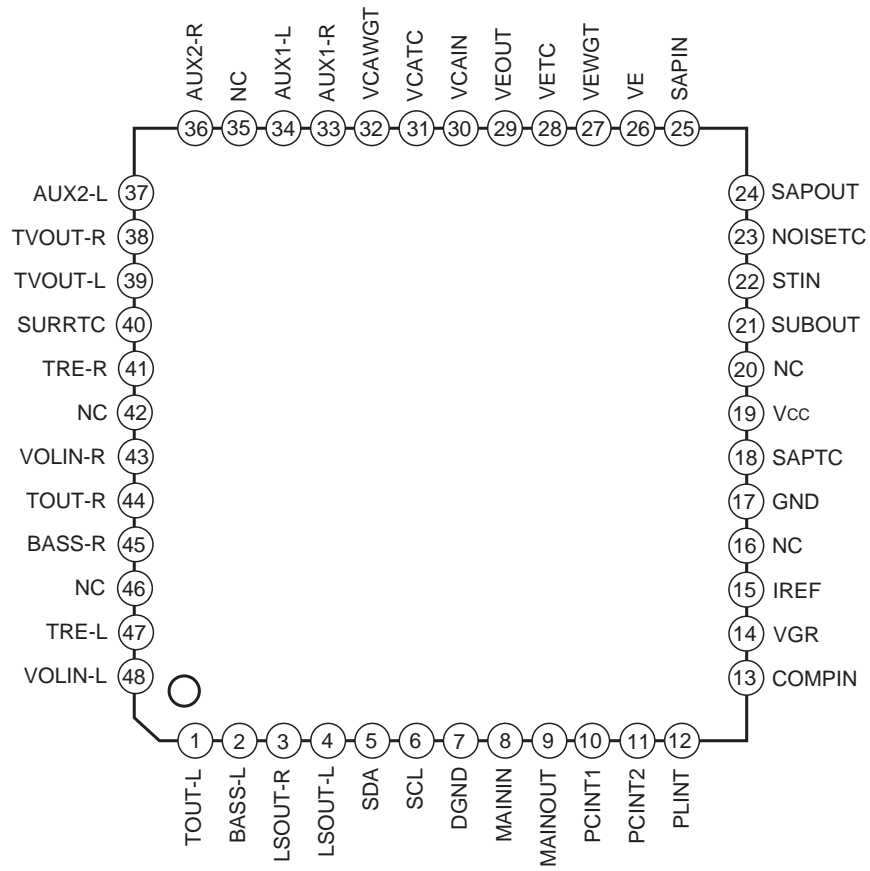

Pin Description

(Ta = 25°C, Vcc = 9V)

Pin No.	Symbol	Pin voltage	Equivalent circuit	Description
1	TOUT-L	4.0V		Treble output pin. (Left channel)
44	TOUT-R	4.0V		Treble output pin. (Right channel)
2	BASS-L	4.0V		Bass filter pin. (Left channel)
45	BASS-R	4.0V		Bass filter pin. (Right channel)
3	LSOUT-R	4.0V		LSOUT right channel output pin.
4	LSOUT-L	4.0V		LSOUT left channel output pin.
5	SDA	—		Serial data I/O pin. $V_{IH} > 3.0V$ $V_{IL} < 1.5V$

Pin No.	Symbol	Pin voltage	Equivalent circuit	Description
6	SCL	—		Serial clock input pin. $V_{IH} > 3.0V$ $V_{IL} < 1.5V$
7	DGND	—		Digital block GND.
8	MAININ	4.0V		Input pin of (L + R) signal from MAINOUT (Pin 9).
9	MAINOUT	4.0V		(L + R) signal output pin.

Pin No.	Symbol	Pin voltage	Equivalent circuit	Description
10	PCINT1	4.0V		Stereo block PLL loop filter integrating pin.
11	PCINT2	4.0V		
12	PLINT	5.1V		Pilot cancel circuit loop filter integrating pin. (Connect a 1μF capacitor between this pin and GND.)
13	COMPIN	4.0V		Audio multiplexing signal input pin.

Pin No.	Symbol	Pin voltage	Equivalent circuit	Description
14	VGR	1.3V		<p>Band gap reference output pin. (Connect a 10μF capacitor between this pin and GND.)</p>
15	IREF	1.3V		<p>Set the filter and VCO reference current. The reference current is adjusted with the BUS DATA based on the current which flows to this pin. (Connect a 62kΩ (\pm1%) resistor between this pin and GND.)</p>
17	GND	—		<p>Analog block GND.</p>
18	SAPTC	4.5V		<p>Set the time constant for the SAP carrier detection circuit. (Connect a 4.7μF capacitor between this pin and GND.)</p>
19	Vcc	—		<p>Supply voltage pin.</p>

Pin No.	Symbol	Pin voltage	Equivalent circuit	Description
21	SUBOUT	4.0V		(L – R) signal output pin.
22	STIN	4.0V		Input pin of (L – R) signal from SUBOUT (Pin 21).
25	SAPIN	4.0V		Input pin of (SAP) signal from SUPOINT (Pin 24).
23	NOISETC	3.0V		Set the time constant for the noise detection circuit. (Connect a 4.7μF capacitor between this pin and GND.)
24	SAPOUT	4.0V		SAP FM detector output pin.

Pin No.	Symbol	Pin voltage	Equivalent circuit	Description
26	VE	4.0V		<p>Variable de-emphasis integrating pin. (Connect a 2700pF capacitor and a 3.3kΩ resistor in series between this pin and GND.)</p>
27	VEWGT	4.0V		<p>Weight the variable de-emphasis control effective value detection circuit. (Connect a 0.047μF capacitor and a 3kΩ resistor in series between this pin and GND.)</p>
28	VETC	1.7V		<p>Determine the restoration time constant of the variable de-emphasis control effective value detection circuit. (The specified restoration time constant can be obtained by connecting a 3.3μF capacitor between this pin and GND.)</p>
29	VEOUT	4.0V		<p>Variable de-emphasis output pin. (Connect a 4.7μF non-polar capacitor between Pins 29 and 30.)</p>

Pin No.	Symbol	Pin voltage	Equivalent circuit	Description
30	VCAIN	4.0V		VCA input pin. Input the variable de-emphasis output signal from Pin 29 via a coupling capacitor.
31	VCATC	1.7V		Determine the restoration time constant of the VCA control effective value detection circuit. (The specified restoration time constant can be obtained by connecting a 10µF capacitor between this pin and GND.)
32	VCAWGT	4.0V		Weight the VCA control effective value detection circuit. (Connect a 1µF capacitor and a 3.9kΩ resistor in series between this pin and GND.)
33	AUX1-R	4.0V		Right channel external input 1 pin.
34	AUX1-L	4.0V		Left channel external input 1 pin.
36	AUX2-R	4.0V		Right channel external input 2 pin.
37	AUX2-L	4.0V		Left channel external input 2 pin.

Pin No.	Symbol	Pin voltage	Equivalent circuit	Description
38	TVOUT-R	4.0V		TVOUT right channel output pin.
39	TVOUT-L	4.0V		TVOUT left channel output pin.
40	SURRTC	4.0V		Set the center frequency of the Surround circuit phase shifter. The frequency is determined by the built-in resistor and the external capacitor. (Connect a 0.022μF capacitor between this pin and GND.)
41	TRE-R	4.0V		Treble filter pin. (Right channel)
47	TRE-L	4.0V		Treble filter pin. (Left channel)
43	VOLIN-R	4.0V		Volume right channel input pin.
48	VOLIN-L	4.0V		Volume left channel input pin.
16 20 35 42 46	NC	—		

Electrical Characteristics
 COMPIN input level
 (100% modulation level)

Main (L + R) (Pre-Emphasis: OFF) = 245mVrms
 SUB (L - R) (dbx-TV: OFF) = 490mVrms
 Pilot = 49mVrms
 SAP Carrier = 147mVrms
 f_H = 15.734kHz

(T_a = 25°C, V_{CC} = 9V)

No.	Item	Signal	Mode	Input pin	Input signal	Measurement conditions	Filter	Output pin	Min.	Typ.	Max.	Unit
1	Current consumption	I _{CC}		—	No signal			19	37	47	57	mA
2	Main output level	V _{main}	MONO	13	Mono 1kHz 100% mod. Pre-em. ON			38/39	440	490	540	mVrms
3	Main de-emphasis frequency response	FC _{deem}	MONO	13	Mono 5kHz 30% mod. Pre-em. ON	20 log ('5k/'1k')		38/39	-1.2	0	1.0	dB
4	Main LPF frequency response	FC _{main}	MONO	13	Mono 12kHz 30% mod. Pre-em. ON	20 log ('12k/'1k')		38/39	-3.0	-1.0	1.0	dB
5	Main distortion	THD _m	MONO	13	Mono 1kHz 100% mod. Pre-em. ON		15kLPF	38/39	—	0.1	0.5	%
6	Main overload distortion	THD _{mmax}	MONO	13	Mono 1kHz 200% mod. Pre-em. ON		15kLPF	38/39	—	0.15	0.5	%
7	Main S/N	SN _{main}	MONO	13	Mono 1kHz, Pre-em. ON	20 log ('100%/0%')	15kLPF	38/39	61	69	—	dB
8	Sub output level	V _{sub}	ST	13	SUB (L-R), 1kHz, 100% mod., NR OFF			21	150	190	230	mVrms
9	Sub LPF frequency response	FC _{sub}	ST	13	SUB (L-R) 12kHz, 30% mod., NR OFF	20 log ('12k/'1k')		21	-3.0	-0.5	1.0	dB
10	Sub distortion	THD _{sub}	ST	13	SUB (L-R) 1kHz, 100% mod., NR OFF		15kLPF	21	—	0.1	1.0	%
11	Sub overload distortion	THD _{smax}	ST	13	SUB (L-R), 1kHz, 200% mod., NR OFF		15kLPF	21	—	0.2	2.0	%
12	Sub S/N	SN _{sub}	ST	13	SUB (L-R) 1kHz, NR OFF	20 log ('100%/0%')	15kLPF	21	56	64	—	dB
13	Crosstalk Stereo → SAP	CT _{st}	SAP	13	ST-L (R), 1kHz, 100% mod., NR ON, SAP Carrier (5H)	20 log ('NRSW = 0/'NRSW = 1')	1kBPf	39	60	70	—	dB
14	Sub pilot leak	PC _{sub}	ST	13	PILOT (fh) 0dB	0dB = 49mVrms	fh BPF	21	—	-38	-27	dB
15	Stereo ON level	TH _{st}				0dB = 49mVrms						
16	Stereo ON/OFF hysteresis			13	Change PILOT (fh) Level			BUS RETURN	-9.0	-6.0	-3.0	dB
						20 log ('on level/'off level')			3.5	6.0	8.5	dB

No.	Item	Symbol	Mode	Input pin	Input signal	Measurement conditions	Filter	Output pin	Min.	Typ.	Max.	Unit
17	SAP output level	Vsap	SAP	13	SAP 1kHz 100% mod. NR OFF			24	130	160	190	mVrms
18	SAP LPF frequency response	FCsap	SAP	13	SAP 10kHz, 30% mod. NR OFF	20 log ('10k'/1k')		24	-3.0	0	2.5	dB
19	SAP distortion	THDsap	SAP	13	SAP 1kHz 100% mod. NR OFF		15kLPF	24	—	2.5	6.0	%
20	SAP S/N	SNSap	SAP	13	SAP 1kHz, NR OFF	20 log ('100%/10%')	15kLPF	24	46	55	—	dB
21	Cross talk SAP → Stereo	CTSap	ST	13	SAP 1kHz 100% mod. NR ON, Pilot (f _H)	20 log (NRSW = 1/NRSW = 0)	1kBPf	39	60	70	—	dB
22	SAP ON level	THsap	SAP	13	Change SAP Carrier (5f _H) Level	0dB = 147mVrms		BUS RETURN	-12.0	-9.0	-6.5	dB
23	SAP ON/OFF hysteresis	HYSap				20 log ('on level'/off level')			2.0	4.0	6.0	dB
24	ST separation 1 L → R	STLsep1	ST	13	ST-L 300Hz 30% mod. NR ON	20 log ('Lch'/Rch')	15kLPF	38/39	23	35	—	dB
25	ST separation 1 R → L	STRsep1	ST	13	ST-R 300Hz 30% mod. NR ON	20 log ('Rch'/Lch')	15kLPF	38/39	23	35	—	dB
26	ST separation 2 L → R	STLsep2	ST	13	ST-L 3kHz 30% mod. NR ON	20 log ('Lch'/Rch')	15kLPF	38/39	23	35	—	dB
27	ST separation 2 R → L	STRsep2	ST	13	ST-R 3kHz 30% mod. NR ON	20 log ('Rch'/Lch')	15kLPF	38/39	23	35	—	dB
28	TVOUT output level	Vtv	EXT	33/34 36/37	Sine wave 1kHz, 490mVrms			38/39	440	490	540	mVrms
29	TVOUT mute amount	MUtv1	INT	13	Mono 1kHz 100% mod. Pre-em. ON	20 log (M1 = "0"/M1 = "1")	1kBPf	38/39	—	-95	-80	dB
30		MUtv2	EXT	33/34 36/37	Sine wave 1kHz, 490mVrms	20 log (M1 = "0"/M1 = "1")			—	-95	-80	dB
31	LSOUT output level	Vls	INT	13	Mono 1kHz 100% mod. Pre-em. ON			3/4	440	490	540	mVrms
32			EXT	33/34 36/37	Sine wave 1kHz, 490mVrms				440	490	540	mVrms
33	LSOUT cross talk EXT → INT	CTIs	INT	33/34 36/37	Sine wave 1kHz, 490mVrms		1kBPf	3/4	—	-75	-60	dB
34	LSOUT cross talk INT → EXT		EXT	13	Mono 1kHz 100% mod. Pre-em. ON		1kBPf	3/4	—	-90	-80	dB

No.	Item	Symbol	Mode	Input pin	Input signal	Measurement conditions	Filter	Output pin	Min.	Typ.	Max.	Unit
35	LSOUT mute amount	MUls	EXT	33/34 36/37	Sine wave 1kHz, 490mVrms	20 log (M2 = "0"/M2 = "1")	1kBPf	3/4	—	-90	-80	dB
36	LSOUT DC offset	OSls	INT EXT	—	No signal	Mute (M2 = "0")/ DC difference when there is no signal		3/4	-25	0	25	mV
37	LSOUT distortion	THDls	EXT	33/34 36/37	Sine wave 1kHz, 490mVrms		15kLPf	3/4	—	0.01	0.5	%
38	LSOUT S/N	SNls	EXT	33/34 36/37	Sine wave 1kHz, 490mVrms		15kLPf	3/4	67	77	—	dB
39	LSOUT overload distortion	THDlsmax	EXT	33/34 36/37	Sine wave 1kHz, 2Vrms		15kLPf	3/4	—	0.03	0.5	%
40	Bass maximum value	TBmax	EXT	33/34 36/37	Sine wave 100Hz, 490mVrms	BASS = "3F"		3/4	9	11	13	dB
41	Bass minimum value	TBmin	EXT	33/34 36/37	Sine wave 100Hz, 490mVrms	BASS = "0"		3/4	-13	-11	-9	dB
42	Treble maximum value	TTmax	EXT	33/34 36/37	Sine wave 10kHz, 490mVrms	TREBLE = "3F"		3/4	9	11	13	dB
43	Treble minimum value	TTmin	EXT	33/34 36/37	Sine wave 10kHz, 490mVrms	TREBLE = "0"		3/4	-13	-11	-9	dB
44	Volume minimum value	VOLmin	EXT	33/34 36/37	Sine wave 1kHz, 490mVrms	VOL-L = "0", VOL-R = "0"	1kBPf	3/4	—	-90	-80	dB
45	SURROUND frequency response 1	Sr1	EXT	34/37	Sine wave 330Hz, 490mVrms			4	1.5	3.0	4.8	dB
46	SURROUND frequency response 2	Sr2	EXT	34/37	Sine wave 10kHz, 490mVrms			4	4.5	6.0	7.5	dB

Adjustment Method

The resistor data is set to the standard value.

1. ATT adjustment

- 1) Input a 100Hz, 245mVrms sine wave signal to COMPIN and monitor the TVOUT-L output level. Then, adjust the "ATT" data for ATT adjustment so that the TVOUT-L output goes to the standard value (490mVrms).
- 2) Adjustment range: $\pm 20\%$
Adjustment bits: 4 bits

2. Separation adjustment

- 1) Input ST-L signal (modulation factor 30%, frequency 300Hz NR-ON) to COMPIN. At this time, adjust the "WIDEBAND" adjustment data to reduce TVOUT-R output to the minimum.
- 2) Next, set the frequency only of the input signal to 3kHz and adjust the "SPECTRAL" adjustment data to reduce TVOUT-R output to the minimum.
- 3) The adjustments in 1 and 2 above are performed to optimize the separation.
- 4) "WIDEBAND" "SPECTRAL"
Adjustment range: $\pm 30\%$ Adjustment range: $\pm 15\%$
Adjustment bits: 6 bits Adjustment bits: 6 bits

Note) Adjust this IC through tuner and IF when this IC is mounted on the set.

Register Specifications

Slave address

Slave receiver	Slave transmitter
84H (1000 0100)	85H (1000 0101)

Register table

Sub address		Data							
MSB	LSB	BIT7	BIT6	BIT5	BIT4	BIT3	BIT2	BIT1	BIT0
****0000		*		TEST-DA	TEST1	ATT			
****0001		*		SPECTRAL					
****0010		*		WIDEBAND					
****0011		*	M2	EXT1	EXT2	NRSW	FOMO	SAPC	M1
****0100		*			SURR	ATTSW	*	FEXT1	FEXT2
****0101		*		BASS					
****0110		*		TREBLE					
****0111		*		VOL-L					
****1000		*		VOL-R					

*: Don't care

Status registers

STA1	STA2	STA3	STA4	STA5	STA6	STA7	STA8
BIT7	BIT6	BIT5	BIT4	BIT3	BIT2	BIT1	BIT0
POWER ON RESET	STEREO	SAP	NOISE	—	—	—	—

Note) The microcomputer reads both SAP and NOISE status and judges SAP discrimination.

Description of Registers

Control registers

Register	Number of bits	Classification*1	Standard setting	Contents
ATT	4	A	9	Input level adjustment
SPECTRAL	6	A	1F	Adjustment of stereo separation (3kHz)
WIDEBAND	6	A	1F	Adjustment of stereo separation (300Hz)
TEST-DA	1	T	0	DAC test mode
TEST1	1	T	0	Test mode
VOL-L	6	U	3F	Left channel volume control
VOL-R	6	U	3F	Right channel volume control
BASS	6	U	1F	Bass control
TREBLE	6	U	1F	Treble control
SURR	1	U	0	Quasi-surround function ON/OFF
NRSW	1	U	0	Selection of the output signal (Stereo mode, SAP mode)
FOMO	1	U	0	Forced MONO. (Left channel only is MONO during SAP output.)
EXT1	1	U	0	Selection of TV mode or external input mode
EXT2	1	U	0	Selection of external input 1 mode or external input 2 mode (EXT1 = 1)
FEXT1	1	U	0	External input 1 forced MONO
FEXT2	1	U	0	External input 2 forced MONO
M1	1	U	1	Selection of TVOUT mute function ON/OFF
M2	1	U	1	Selection of LSOUT mute function ON/OFF
ATTSW	1	S	0	Main VCA ON/OFF
SAPC	1	S	0	Selection of SAP mode or L + R mode according to the presence of SAP broadcasting

*1 Classification U: User control
A: Adjustment
S: Proper to set
T: Test

Status registers

Register	Number of bits	Contents
PONRES	1	POWER ON RESET detection; 1: RESET
STEREO	1	Stereo discrimination of the COMPIN input signal; 1: Stereo
SAP	1	SAP discrimination of the COMPIN input signal; 1: SAP
NOISE	1	Noise level discrimination of the SAP input signal; 1: Noise

Description of Control Registers

ATT (4): Perform input level adjustment.

0 = Level Min.

F = Level Max.

SPECTRAL (6): Perform high frequency ($f_s = 3\text{kHz}$) separation adjustment.

0 = Level Max.

3F = Level Min.

WIDEBAND (6): Perform low frequency ($f_s = 300\text{Hz}$) separation adjustment.

0 = Level Min.

3F = Level Max.

TEST-DA (1): Set DAC output test mode.

0 = Normal mode

1 = DAC output test mode

In addition, the following outputs are present at Pin 39.

TVOUT-L (Pin 39): DA control DC level

TEST1 (1): Monitor SAPBPF and NRBPF outputs.

0 = Normal mode

1 = SAPBPF, NRBPF outputs

In addition, the following outputs are present at Pins 39 and 38.

TVOUT-L (Pin 39): SAP BPF OUT

TVOUT-R (Pin 38): NR BPF OUT

VOL-L (6): LSOUT-L output signal level control

0 = Volume Min.

3F= Volume Max.

-1.25 dB/STEP

VOL-R (6): LSOUT-R output signal level control

0 = Volume Min.

3F= Volume Max.

-1.25 dB/STEP

BASS (6): LSOUT output bass control

0 = Bass Min.

1F = Bass Center

3F = Bass Max.

TREBLE (6): LSOUT output treble control

0 = Treble Min.

1F = Treble Center

3F = Treble Max.

- SURR (1): Surround function selection
0 = Surround OFF
1 = Surround ON
- NRSW (1): Select stereo mode or SAP mode
0 = Stereo mode
1 = SAP mode
- FOMO (1): Select forced MONO mode
0 = Normal mode
1 = Forced MONO mode
- EXT1 (1): Select TV mode or external input mode for TVOUT output.
0 = TV mode
1 = External input mode
- EXT2 (1): Select external input [1] mode or external input [2] mode for TVOUT output. (EXT1 = 1)
0 = External input [1] mode
1 = External input [2] mode
- FEXT1 (1): Turn external input [1] to forced MONO.
0 = Normal mode
1 = External input [1] is forced MONO.
Input the same signal to both AUX1-L and AUX1-R.
- FEXT2 (1): Turn external input [2] to forced MONO
0 = Normal mode
1 = External input [2] is forced MONO
Input the same signal to both AUX2-L and AUX2-R.
- M1 (1): Mute the TVOUT-L and TVOUT-R output.
0 = Mute ON
1 = Mute OFF
- M2 (1): Mute the LSOUT-L and LSOUT-R output.
0 = Mute ON
1 = Mute OFF
- ATTSW (1) Select BYPASS SW of MVCA
0 = Normal mode
1 = MVCA is passed
- SAPC (1): Select the SAP signal output mode
When there is no SAP signal, the conditions for selecting SAP output are selected by SAPC.
0 = L + R output is selected
1 = SAP output is selected

Description of Mode Control

	SAPC = 0	SAPC = 1
NRSW	<p>“Select dbx input and TV decoder output” Conditions: FOMO = 0 NRSW = 0 (MONO or ST output)</p> <ul style="list-style-type: none"> • During ST input: left channel: L, right channel: R • During other input: left channel: L + R, right channel: L + R <p>NRSW = 1 (SAP output)</p> <ul style="list-style-type: none"> • When there is “SAP” during SAP discrimination – left channel: SAP, right channel: SAP • When there is “No SAP”, output is the same as when NRSW = 0. 	<p>“Select dbx input and TV decoder output” Conditions: FOMO = 0 NRSW = 0 (MONO or ST output)</p> <p>As on the left</p> <p>NRSW = 1 (SAP output)</p> <ul style="list-style-type: none"> • Regardless of the presence of SAP discrimination, dbx input: “SAP” left channel: SAP, right channel: SAP However, when there is no SAP, SAPOUT output is soft muted (–7dB)
FOMO	<p>“Forced MONO”</p>	
	<p>FOMO = 1</p> <ul style="list-style-type: none"> • During SAP output: left channel: L + R, right channel: SAP • During ST or MONO output: left channel: L + R, right channel: L + R 	
SAPC	<p>Change the selection conditions for “MONO or ST output” and “SAP output”.</p> <p>SAPC = 0: Switch to SAP output when there is SAP discrimination. Do not switch to SAP output when there is no SAP discrimination.</p> <p>SAPC = 1: Switch to SAP output regardless of whether there is SAP discrimination.</p>	

Decoder Output and Mode Control Table 1 (SAPC = 1)

Input signal mode	Mode detection			Mode control			dbx input	Output	
	ST	SAP	NOISE	NRSW	FOMO	SAPC		Lch	Rch
MONO*1	0	0	0	0	*	1	MUTE	L + R	L + R
	0	0	0	1	0	1	SAP	SAP	SAP
	0	0	0	1	1	1	SAP	L + R	SAP
	0	*	1	0	*	1	MUTE	L + R	L + R
	0	*	1	1	0	1	(SAP)	(SAP)	(SAP)
	0	*	1	1	1	1	(SAP)	L + R	(SAP)
STEREO*1	1	0	*	0	0	1	L - R	L	R
	1	0	*	0	1	1	MUTE	L + R	L + R
	1	1	1	0	0	1	L - R	L	R
	1	1	1	0	1	1	MUTE	L + R	L + R
	1	0	0	1	0	1	SAP	SAP	SAP
	1	0	0	1	1	1	SAP	L + R	SAP
	1	*	1	1	0	1	(SAP)	(SAP)	(SAP)
	1	*	1	1	1	1	(SAP)	L + R	(SAP)
MONO & SAP	0	1	*	0	0	1	MUTE	L + R	L + R
	0	1	*	0	1	1	MUTE	L + R	L + R
	0	1	0	1	0	1	SAP	SAP	SAP
	0	1	0	1	1	1	SAP	L + R	SAP
	0	1	1	1	0	1	(SAP)	(SAP)	(SAP)
	0	1	1	1	1	1	(SAP)	L + R	(SAP)
STEREO & SAP	1	1	*	0	0	1	L - R	L	R
	1	1	*	0	1	1	MUTE	L + R	L + R
	1	1	0	1	0	1	SAP	SAP	SAP
	1	1	0	1	1	1	SAP	L + R	SAP
	1	1	1	1	0	1	(SAP)	(SAP)	(SAP)
	1	1	1	1	1	1	(SAP)	L + R	(SAP)

Note

(SAP) : The SAPOUT output signal is soft muted (approximately -7dB).

The signal is soft muted when NOISE = 1.

* : Don't care.

*1 SAP or NOISE discrimination may be made during MONO or STEREO input when the noise is input in the weak electric field.

Then microcomputer reads "NOISE" status from IC and decides whether SAP is output.

"NOISE" status rises earlier than "SAP" status when the amount of noise is increased to COMPIN.

Decoder Output and Mode Control Table 2 (SAPC = 0)

Input signal mode	Mode detection			Mode control			dbx input	Output	
	ST	SAP	NOISE	NRSW	FOMO	SAPC		Lch	Rch
MONO *1	0	0	*	*	*	0	MUTE	L + R	L + R
	0	1	1	0	0	0	MUTE	L + R	L + R
	0	1	1	0	1	0	MUTE	L + R	L + R
	0	1	1	1	0	0	(SAP)	(SAP)	(SAP)
	0	1	1	1	1	0	(SAP)	L + R	(SAP)
STEREO *1	1	0	*	0	0	0	L - R	L	R
	1	0	*	0	1	0	MUTE	L + R	L + R
	1	0	*	1	0	0	L - R	L	R
	1	0	*	1	1	0	MUTE	L + R	L + R
	1	1	1	0	0	0	L - R	L	R
	1	1	1	0	1	0	MUTE	L + R	L + R
	1	1	1	1	0	0	(SAP)	(SAP)	(SAP)
	1	1	1	1	1	0	(SAP)	L + R	(SAP)
MONO & SAP	0	1	0	0	0	0	MUTE	L + R	L + R
	0	1	0	0	1	0	MUTE	L + R	L + R
	0	1	0	1	0	0	SAP	SAP	SAP
	0	1	0	1	1	0	SAP	L + R	SAP
	0	1	1	0	0	0	MUTE	L + R	L + R
	0	1	1	0	1	0	MUTE	L + R	L + R
	0	1	1	1	0	0	(SAP)	(SAP)	(SAP)
	0	1	1	1	1	0	(SAP)	L + R	(SAP)
STEREO & SAP	1	1	0	0	0	0	L - R	L	R
	1	1	0	0	1	0	MUTE	L + R	L + R
	1	1	0	1	0	0	SAP	SAP	SAP
	1	1	0	1	1	0	SAP	L + R	SAP
	1	1	1	0	0	0	L - R	L	R
	1	1	1	0	1	0	MUTE	L + R	L + R
	1	1	1	1	0	0	(SAP)	(SAP)	(SAP)
	1	1	1	1	1	0	(SAP)	L + R	(SAP)

Note

(SAP) : The SAPOUT output signal is soft muted (approximately -7dB).

The signal is soft muted when NOISE = 1.

* : Don't care.

*1 SAP or NOISE discrimination may be made during MONO or STEREO input when the noise is input in the weak electric field.

Then microcomputer reads "NOISE" status from IC and decides whether SAP is output.

"NOISE" status rises earlier than "SAP" status when the amount of noise is increased to COMPIN.

Mode Control Table 3

	M1	EXT1	EXT2	FEXT1	FEXT2	TVOUT-L	TVOUT-R
1	0	–	–	–	–	MUTE	MUTE
2	1	0	–	–	–	TV (L)	TV (R)
3	1	1	0	0	–	AUX1-L	AUX1-R
4	1	1	0	1	–	AUX1-L	AUX1-L
5	1	1	1	–	0	AUX2-L	AUX2-R
6	1	1	1	–	1	AUX2-L	AUX2-L

TV (L) / TV (R) are selected in MATRIX

TV (L): MONO, ST-L, SAP

TV (R): MONO, ST-R, SAP

Description of Operation

The US audio multiplexing system possesses the base-band spectrum shown in Fig. 1.

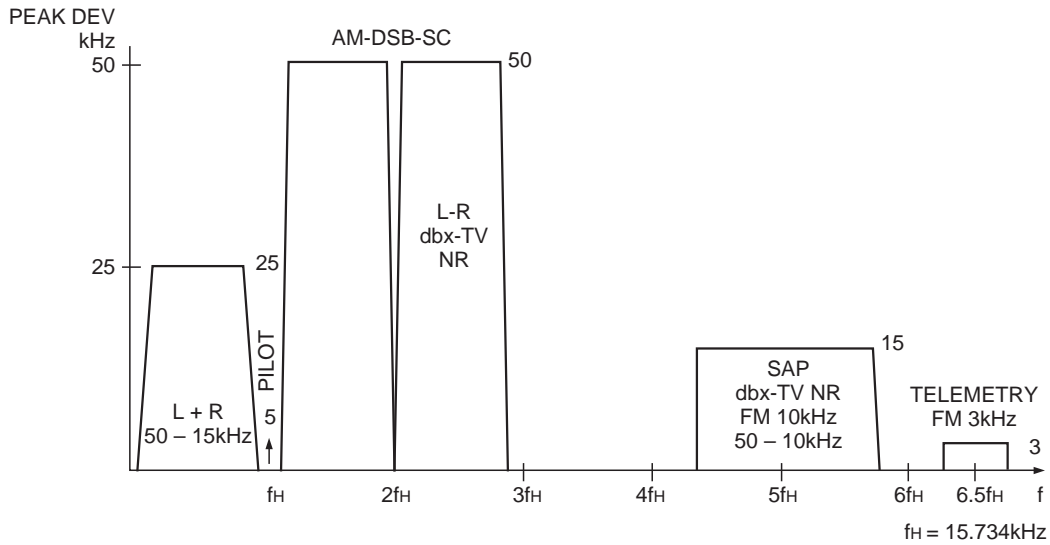

Fig. 1. Base-band spectrum

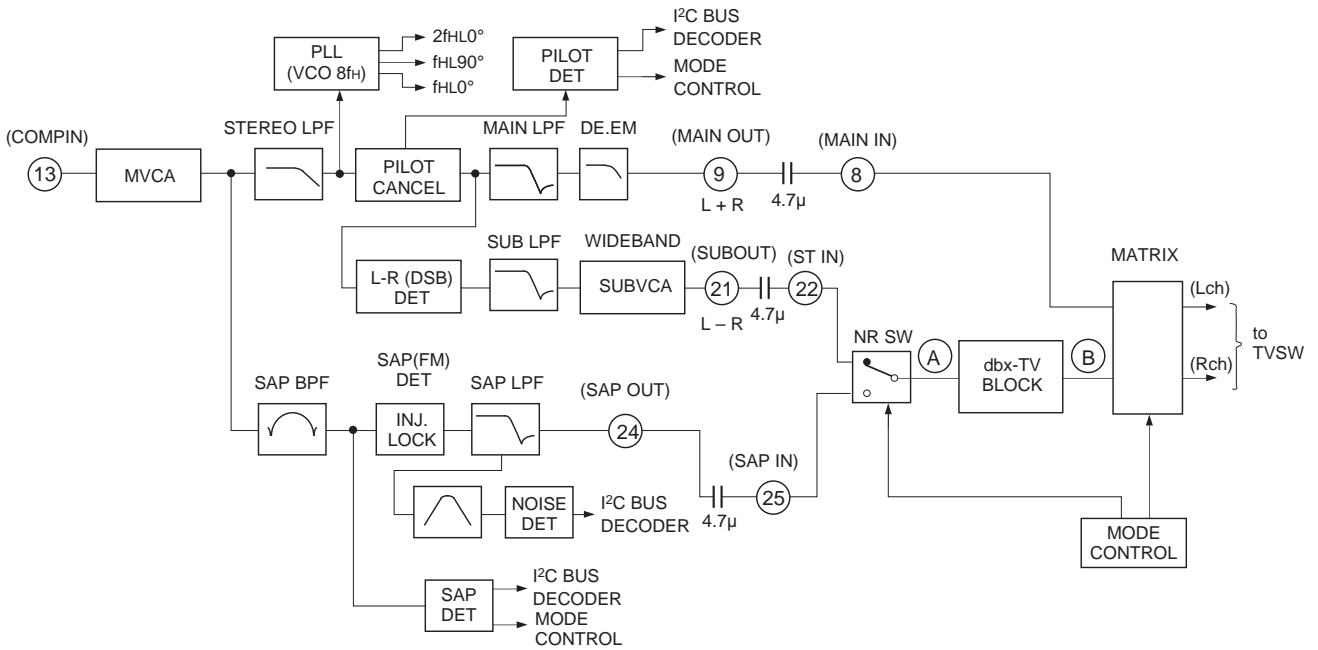

Fig. 2. Overall block diagram (See Fig. 3 for the dbx-TV block)

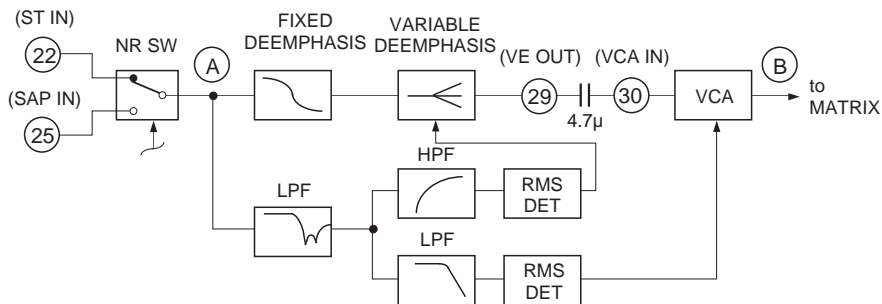

Fig 3. dbx-TV block

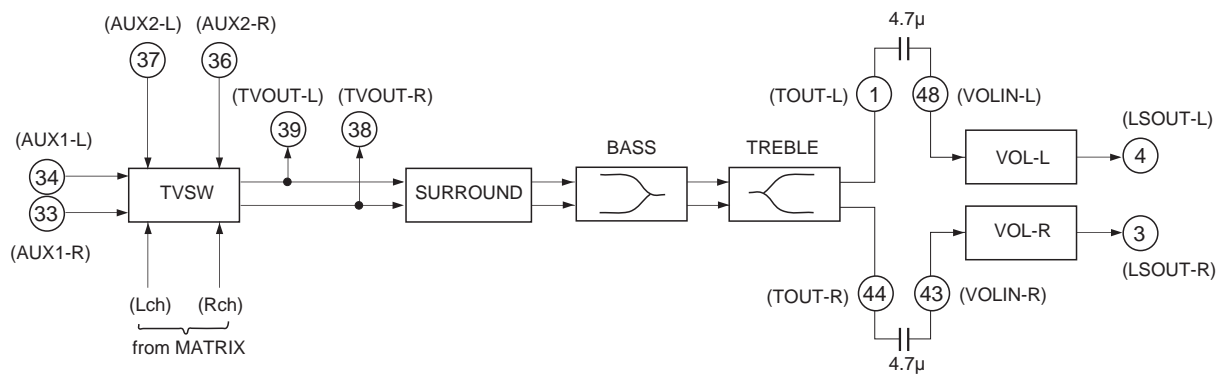

Fig. 4. Sound processor block

(1) L + R (MAIN)

After the audio multiplexing signal input from COMPIN (Pin 13) passes through MVCA, the SAP signal and telemetry signal are suppressed by STEREO LPF. Next, the pilot signals are canceled. Finally, the L – R signal and SAP signal are removed by MAIN LPF, and the frequency response is flattened (de-emphasized) and input to the matrix.

(2) L – R (SUB)

The L – R signal follows the same course as L + R before the pilot signal is canceled. L – R has no carrier signal, as it is a suppressed-carrier double-sideband amplitude modulated signal (DSB-AM modulated). For this reason, the pilot signal is used to regenerate the carrier signal (quasi-sine wave) to be used for the demodulation of the L – R signal. In the last stage, the residual high frequency components are removed by SUB LPF and the L – R signal is input to the dbx-TV block via the NRSW circuit after passing through SUBVCA.

(3) SAP

SAP is an FM signal using 5fH as a carrier as shown in the Fig. 1. First, the SAP signal only is extracted using SAP BPF. Then, this is subjected to FM detection. Finally, residual high frequency components are removed and frequency response flattened using SAP LPF, and the SAP signal is input to the dbx-TV block via the NRSW circuit. When there is no SAP signal, the Pin 24 output is soft muted.

(4) Mode discrimination

Stereo discrimination is performed by detecting the pilot signal amplitude. SAP discrimination is performed by detecting the 5fH carrier amplitude. NOISE discrimination is performed by detecting the noise near 25kHz after FM detection of SAP signal.

(5) dbx-TV block

Either the L – R signal or SAP signal input respectively from ST IN (Pin 22) or SAP IN (Pin 25) is selected by the mode control and input to the dbx-TV block.

The input signal then passes through the fixed de-emphasis circuit and is applied to the variable de-emphasis circuit. The signal output from the variable de-emphasis circuit passes through an external capacitor and is applied to VCA (voltage control amplifier). Finally, the VCA output is converted from a current to a voltage using an operational amplifier and then input to the matrix.

The variable de-emphasis circuit transmittance and VCA gain are respectively controlled by Each of effective value detection circuits. Each of the effective value detection circuits passes the input signal through a predetermined filter for weighting before the effective value of the weighted signal is detected to provide the control signal.

(6) Matrix, TVSW

The signals (L + R, L – R, SAP) input to "MATRIX" become the outputs for the ST-L, ST-R, MONO and SAP signals according to the BUS data and whether there is ST / SAP discrimination.

"TVSW" switches the "MATRIX" output signal, external input signal (input to AUX1-L, R), external input signal (input to AUX2-L, R) and external forced MONO.

(7) Sound processor block

The sound processor block contains "SURROUND" (quasi-surround function), "BASS/TREBLE" tone control functions, and "VOLUME".

• Surround

At "SURROUND", the L and R differential components are phase-shifted and these components are added to the left and right channels.

When surround is OFF (SURR = 0)

Inputs are output as is.

$$\begin{cases} L_{out} = L_{in} \\ R_{out} = R_{in} \end{cases}$$

When surround is ON (SURR = 1)

$$\begin{cases} L_{out} = L_{in} - \frac{1 - j\omega RC}{1 + j\omega RC} (L_{in} - R_{in}) \\ R_{out} = R_{in} + \frac{1 - j\omega RC}{1 + j\omega RC} (L_{in} - R_{in}) \end{cases}$$

$$\begin{cases} R = 24k\Omega \text{ (On-chip)} \end{cases}$$

$$\begin{cases} C = 0.022\mu\text{F} \text{ (Externally attached to Pin 40)} \end{cases}$$

(L_{in}, L_{out}) and R_{in}, (R_{out}) indicate the left- and right- channel I/O of the surround circuit.

(8) Others

"MVCA" is a VCA which adjusts the input signal level to the standard level of this IC.

"Bias" supplies the reference voltage and reference current to the other blocks. The current flowing to the resistor connecting IREF (Pin 15) with GND become the reference current.

Application Circuit

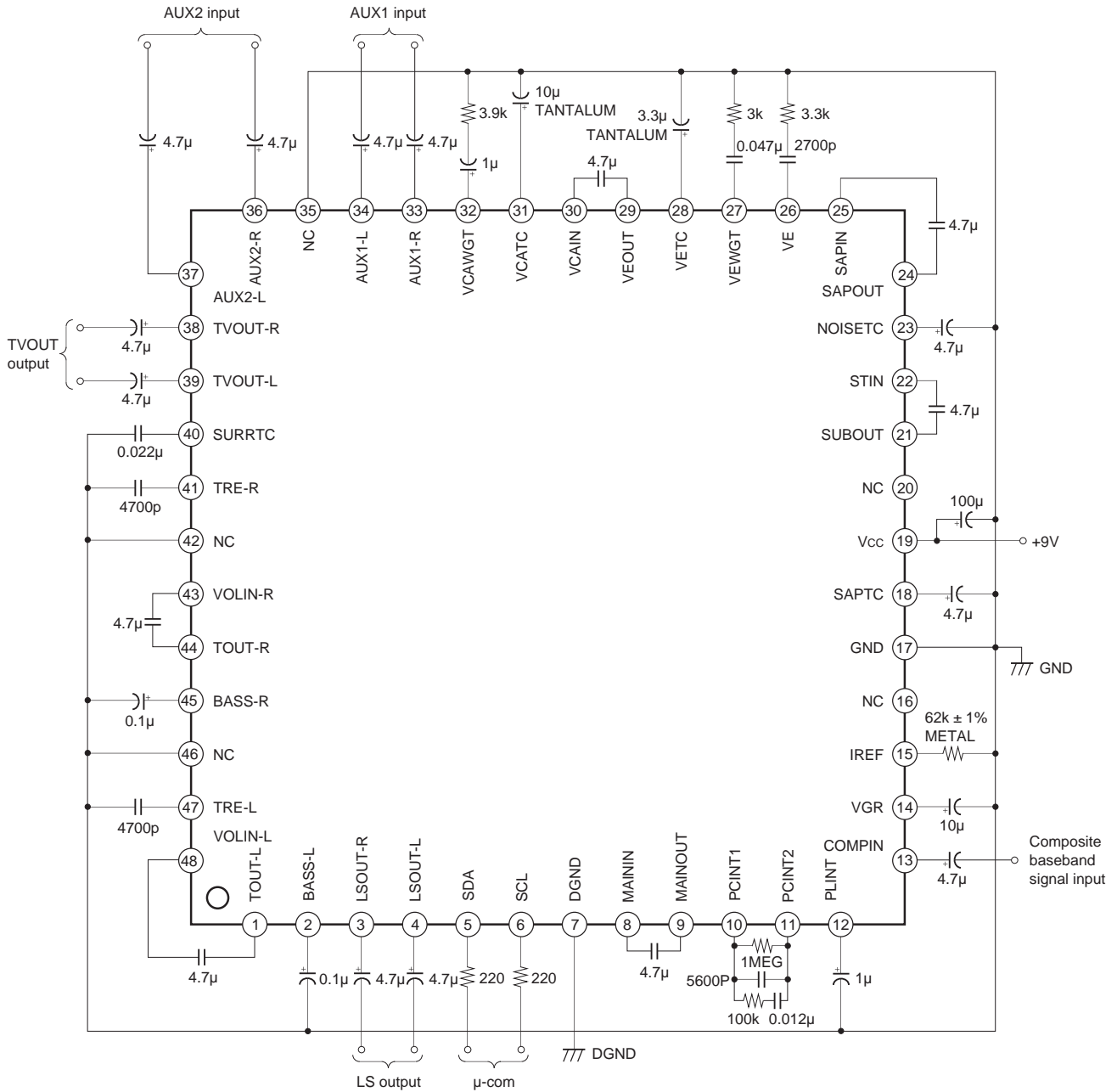

Application circuits shown are typical examples illustrating the operation of the devices. Sony cannot assume responsibility for any problems arising out of the use of these circuits or for any infringement of third party patent and other right due to same.

I²C Bus Block Items (SDA, SCL)

No.	Item	Symbol	Min.	Typ.	Max.	Unit
1	High level input voltage	V _{IH}	3.0	—	5.0	V
2	Low level input voltage	V _{IL}	0	—	1.5	
3	High level input current	I _{IH}	—	—	10	μA
4	Low level input current	I _{IL}	—	—	10	
5	Low level output voltage SDA (Pin 5) during 3mA inflow	V _{OL}	0	—	0.4	V
6	Maximum inflow current	I _{OL}	3	—	—	mA
7	Input capacitance	C _I	—	—	10	pF
8	Maximum clock frequency	f _{SCL}	0	—	100	kHz
9	Minimum waiting time for data change	t _{BUF}	4.7	—	—	μs
10	Minimum waiting time for start of data transfer	t _{HD: STA}	4.0	—	—	
11	Low level clock pulse width	t _{LOW}	4.7	—	—	
12	High level clock pulse width	t _{HIGH}	4.0	—	—	
13	Minimum waiting time for start preparation	t _{SU: STA}	4.7	—	—	
14	Minimum data hold time	t _{HD: DAT}	0	—	—	
15	Minimum data preparation time	t _{SU: DAT}	250	—	—	ns
16	Rise time	t _R	—	—	1	μs
17	Fall time	t _F	—	—	300	ns
18	Minimum waiting time for stop preparation	t _{SU: STO}	4.7	—	—	μs

I²C bus load conditions: Pull-up resistor 4kΩ (Connect to +5V)
 Load capacitor 200pF (Connect to GND)

I²C Bus Control Signal

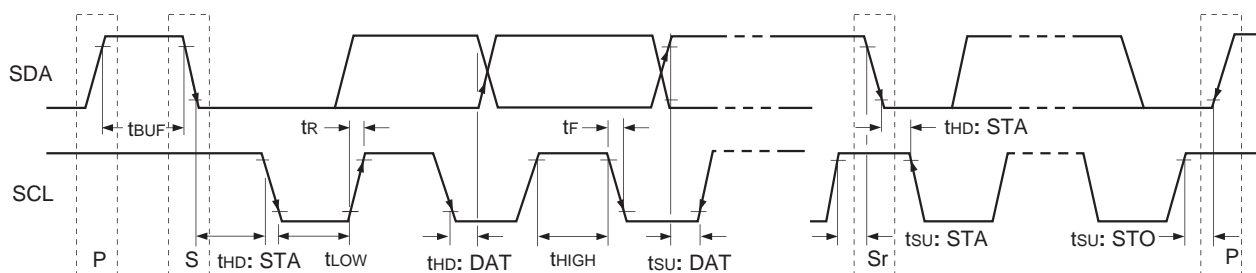

I²C Bus Signal

There are two I²C bus signals, SDA (Serial DATA) and SCL (Serial CLOCK) signals. SDA is a bidirectional signal.

- Accordingly there are 3 values outputs, H, L and Hi-Z.

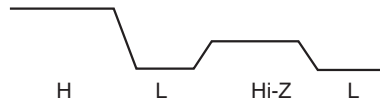

- I²C transfer begins with Start Condition and ends with Stop Condition.

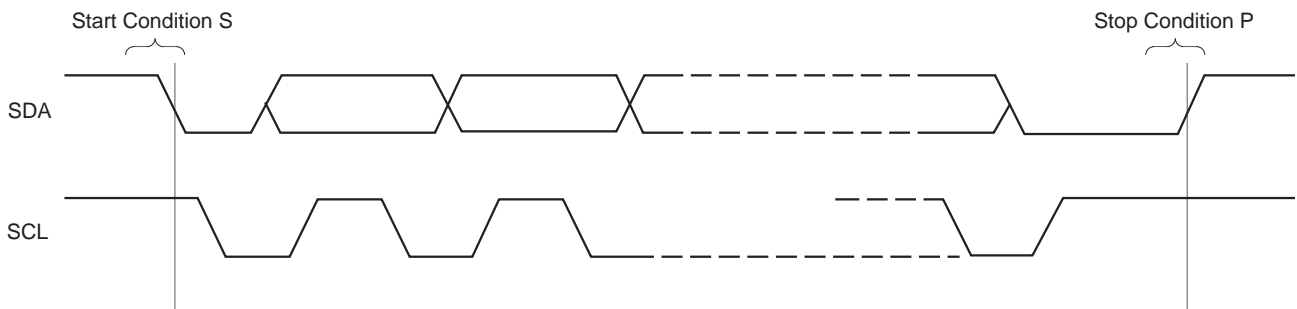

• I²C data Write (Write from I²C controller to the IC)

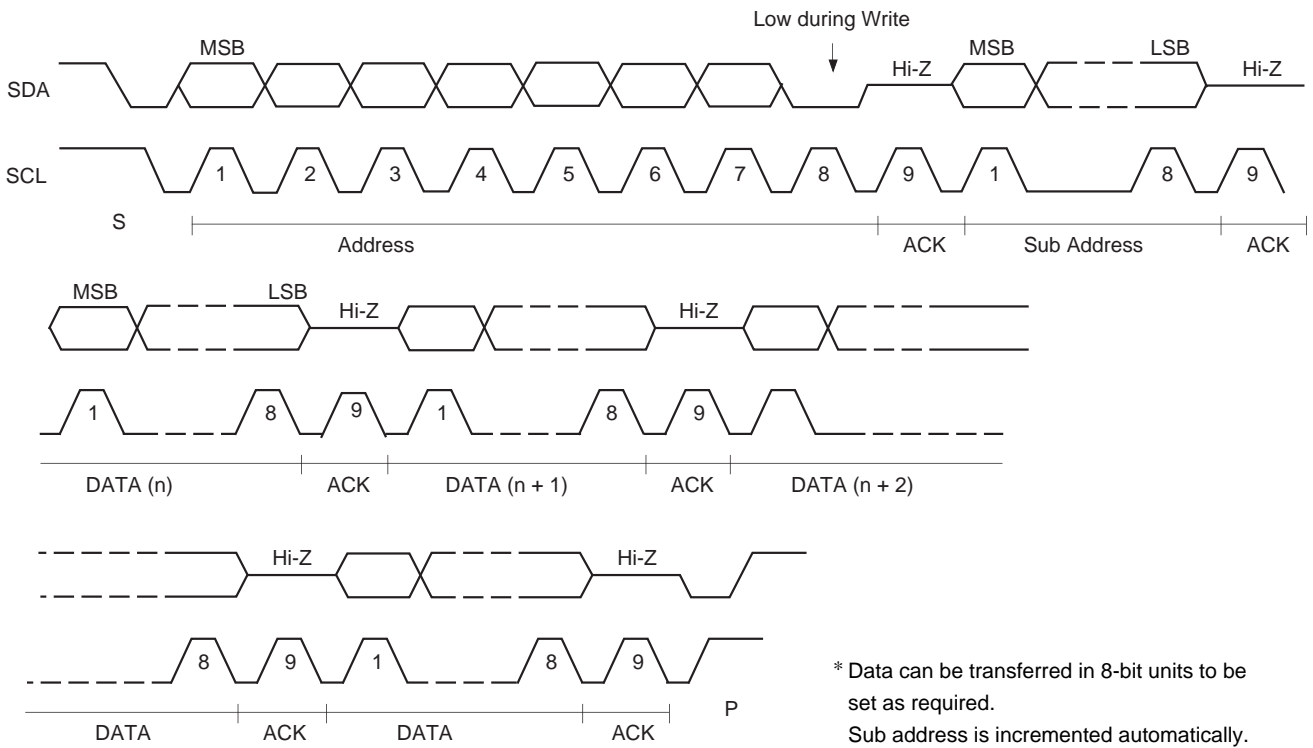

• I²C data Read (Read from the IC to I²C controller)

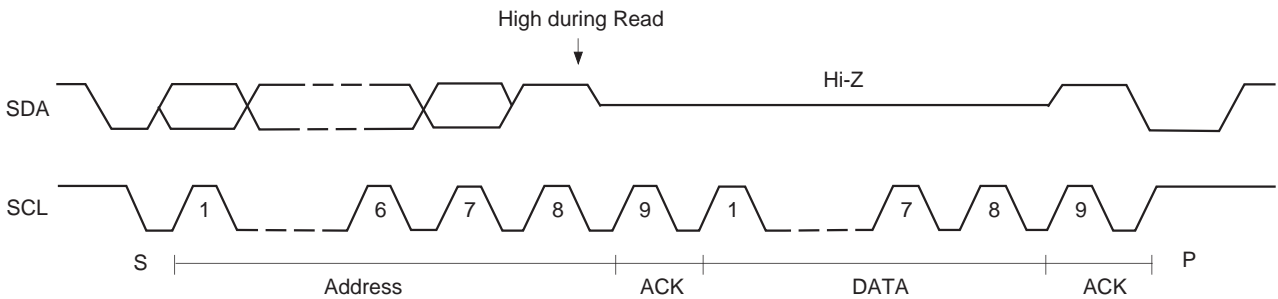

• Read timing

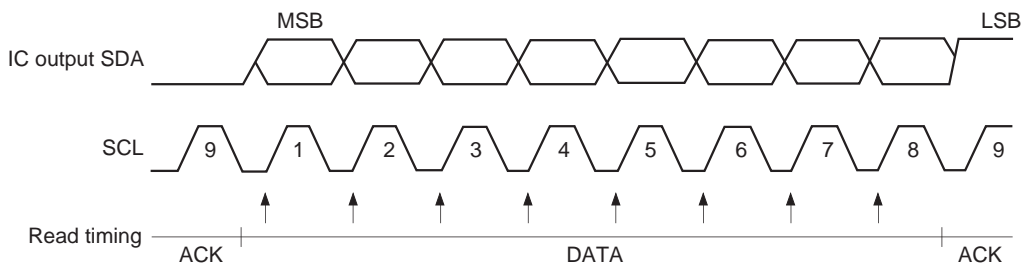

* Data Read is performed during SCL rise.

Input level vs. Distortion characteristics 1 (MONO)

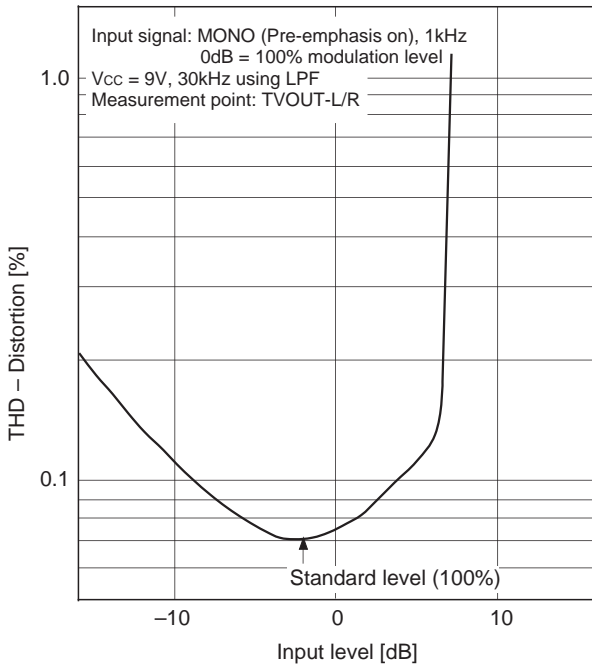

Input level vs. Distortion characteristics 2 (Stereo)

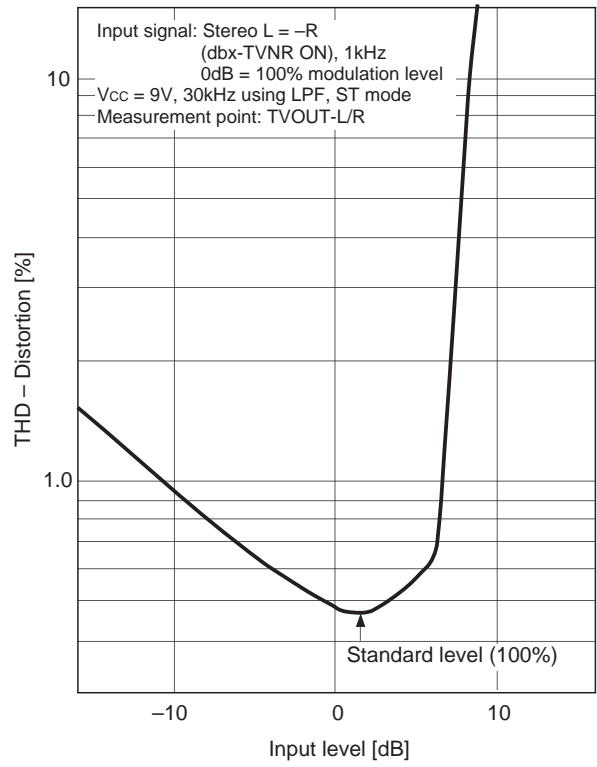

Input level vs. Distortion characteristics 3 (SAP)

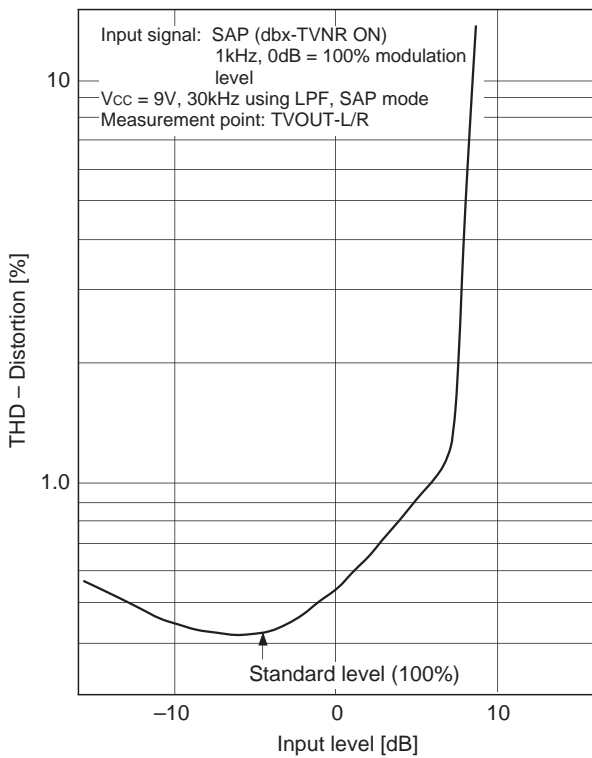

Stereo LPF frequency response

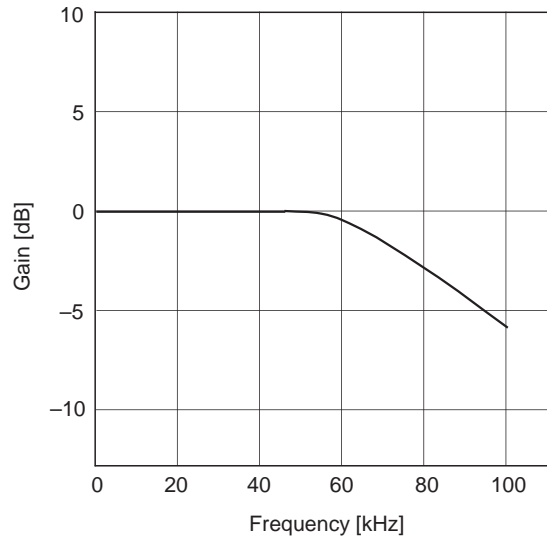

Main LPF and Sub LPF frequency response

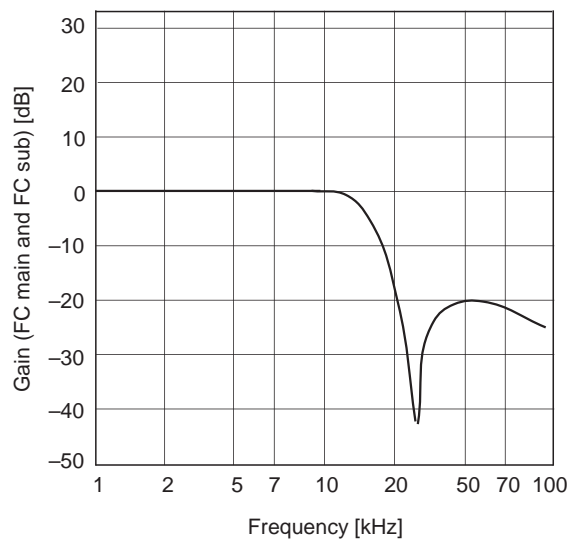

SAP frequency response and group delay

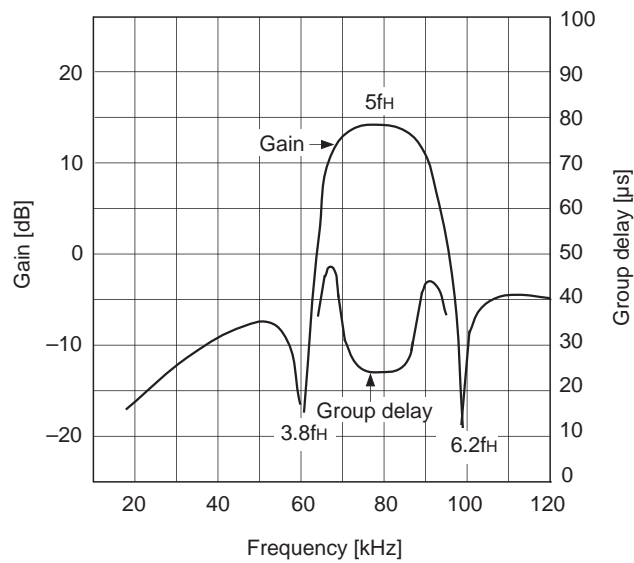

Volume characteristics

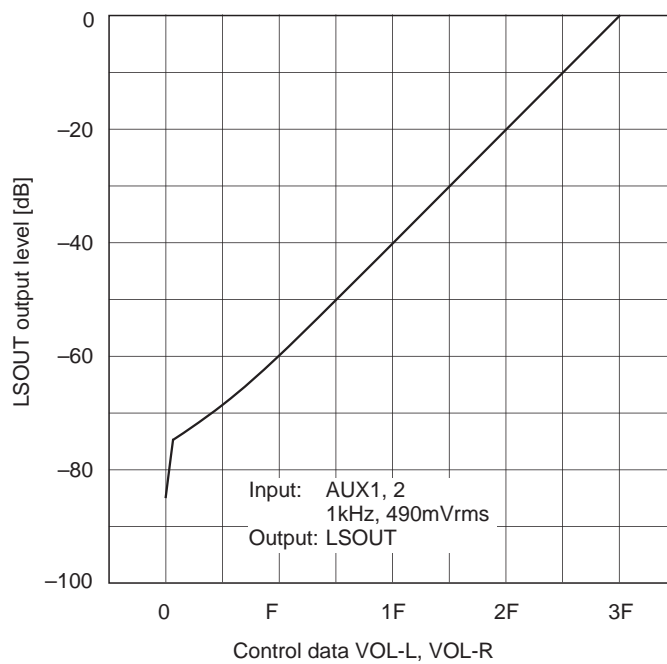

Package Outline

Unit: mm

48PIN QFP (PLASTIC)

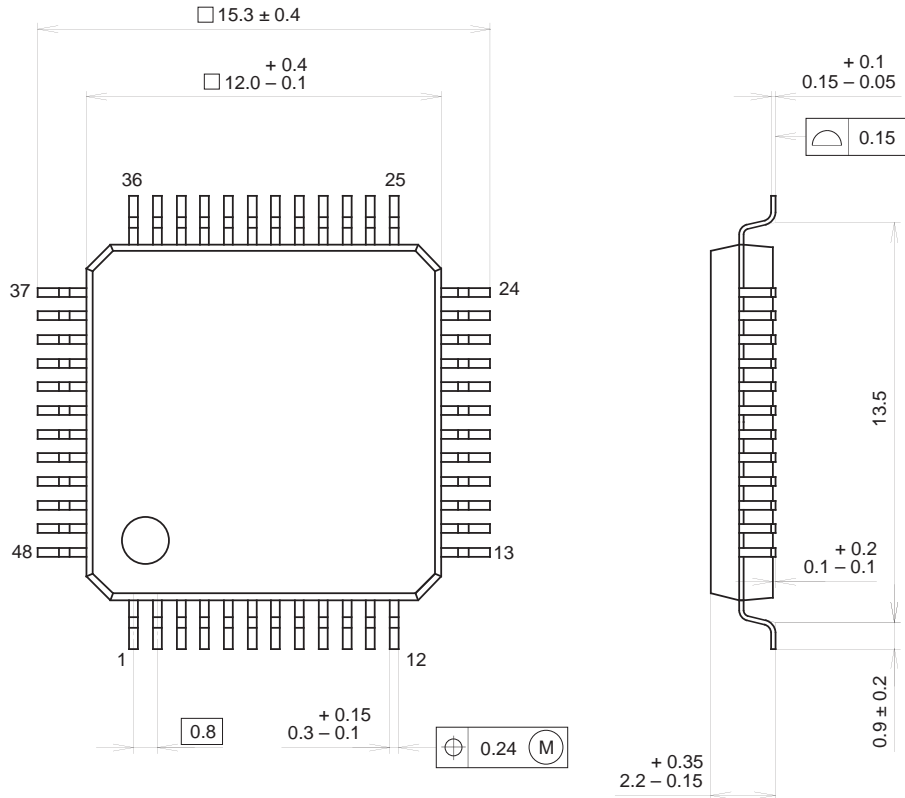

PACKAGE STRUCTURE

SONY CODE	QFP-48P-L04
EIAJ CODE	QFP048-P-1212
JEDEC CODE	—

PACKAGE MATERIAL	EPOXY RESIN
LEAD TREATMENT	SOLDER / PALLADIUM PLATING
LEAD MATERIAL	42/COPPER ALLOY
PACKAGE MASS	0.7g

NOTE : PALLADIUM PLATING

This product uses S-PdPPF (Sony Spec.-Palladium Pre-Plated Lead Frame).