

FEATURES

- 10-Bit, 20 MSPS Analog-to-Digital Converter
- Monolithic CMOS
- Internal Track-and-Hold
- Low Input Capacitance: 1.4 pF
- Low Power Dissipation: 79 mW
- 2.8 – 3.6 V Power Supply Range
- TTL-Compatible Outputs
- –40 °C to +85 °C Operation

APPLICATIONS

- CCD Imaging Cameras and Sensors
- Medical Imaging
- RF Communications
- Document and Film Scanners
- Electro-Optics
- Transient Signal Analysis
- Handheld Equipment

GENERAL DESCRIPTION

The SPT7851 10-bit, 20 MSPS analog-to-digital converter has a pipelined converter architecture built in a CMOS process. It delivers high performance with a typical power dissipation of only 79 mW. With low distortion and high dynamic

range, this device offers the performance needed for imaging, multimedia, telecommunications and instrumentation applications.

The SPT7851 is available in a 44-lead Thin Quad Flat Pack (TQFP) package in the industrial temperature range (–40 °C to +85 °C).

BLOCK DIAGRAM

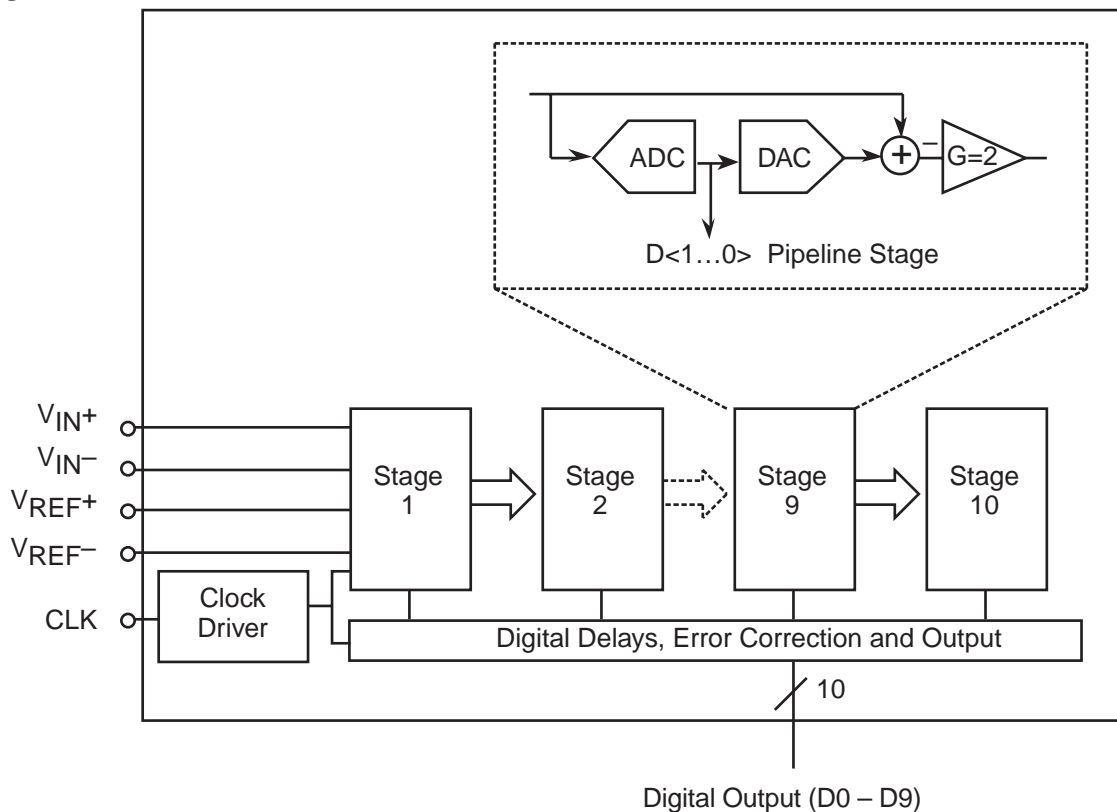

Signal Processing Technologies, Inc.

4755 Forge Road, Colorado Springs, Colorado 80907, USA

Phone: (719) 528-2300 FAX: (719) 528-2370 Website: <http://www.spt.com> E-Mail: sales@spt.com

ABSOLUTE MAXIMUM RATINGS (Beyond which damage may occur)¹ 25 °C

Supply Voltages

| | |
|------------------------|----------------|
| V _{DD1} | -0.5 V to +6 V |
| V _{DD2} | -0.5 V to +6 V |
| V _{DD3} | -0.5 V to +6 V |

Temperature

| | |
|-----------------------------|----------------|
| Operating Temperature | -40 to +85 °C |
| Storage Temperature | -65 to +125 °C |

Input Voltages

| | |
|-------------------------|------------------------------------|
| Analog Input | -0.5 V to (V _{DD} +0.5 V) |
| Digital Input | -0.5 V to (V _{DD} +0.5 V) |
| V _{REF+} | -0.5 V to (V _{DD} +0.5 V) |
| V _{REF-} | -0.5 V to (V _{DD} +0.5 V) |
| CLK | -0.5 V to (V _{DD} +0.5 V) |

Note: 1. Operation at any Absolute Maximum Rating is not implied. See Electrical Specifications for proper nominal applied conditions in typical applications.

ELECTRICAL SPECIFICATIONS

T_A = T_{MIN}-T_{MAX}, V_{DD1} = V_{DD2} = V_{DD3} = 3.3 V, V_{REF-} = 1.0 V, V_{REF+} = 2.0 V, Common Mode Voltage = 1.65 V, f_{CLK} = 20 MSPS, Bias 1 = 90 μA, Bias 2 = 9.5 μA, Differential Input, Duty Cycle = 50%, unless otherwise specified.

| PARAMETERS | TEST CONDITIONS | TEST LEVEL | SPT7851 | | | UNITS |
|--|---|------------|---------|------------|------|--------|
| | | | MIN | TYP | MAX | |
| DC Accuracy | | | | | | |
| Resolution | | | | 10 | | Bits |
| Differential Linearity | | V | | ±0.6 | | LSB |
| Integral Linearity | | V | | ±0.75 | | LSB |
| No Missing Codes | | VI | | Guaranteed | | |
| Analog Input | | | | | | |
| Input Voltage Range (Differential) | | IV | ±0.6 | ±1.0 | ±1.7 | V |
| Common Mode Input Voltage | | IV | 1.2 | 1.65 | 1.9 | V |
| Input Capacitance | | V | | 1.4 | | pF |
| Input Bandwidth (Large Signal) | | V | | 120 | | MHz |
| Offset (Mid-scale) | V _{IN+} = V _{IN-} = V _{CM} | V | | ±1.0 | | % FSR |
| Gain Error | | V | | 0.3 | | % FSR |
| Reference Voltages | | | | | | |
| Reference Input Voltage Range (V _{REF+} - V _{REF-}) | | IV | 0.6 | 1.0 | 1.7 | V |
| Negative Reference Voltage (V _{REF-}) | | IV | 0.9 | 1.0 | 1.3 | V |
| Positive Reference Voltage (V _{REF+}) | | IV | 1.9 | 2.0 | 2.9 | V |
| Common Mode Output Voltage (V _{CM}) | I _O = -1 μA | VI | 1.3 | 1.65 | 1.8 | V |
| V _{REF+} Current | | V | | 35 | | μA |
| V _{REF-} Current | | V | | -25 | | μA |
| Switching Performance | | | | | | |
| Maximum Conversion Rate | | VI | 20 | | | MHz |
| Pipeline Delay (See Timing Diagram) | | IV | | 7.5 | | Clocks |
| Aperture Delay Time (T _{AP}) | | V | | 5 | | ns |
| Aperture Jitter Time | | V | | 10 | | ps-rms |

ELECTRICAL SPECIFICATIONS

$T_A = T_{MIN} - T_{MAX}$, $V_{DD1} = V_{DD2} = V_{DD3} = 3.3\text{ V}$, $V_{REF-} = 1.0\text{ V}$, $V_{REF+} = 2.0\text{ V}$, Common Mode Voltage = 1.65 V, $f_{CLK} = 20\text{ MSPS}$, Bias 1 = 90 μA , Bias 2 = 9.5 μA , Differential Input, Duty Cycle = 50%, unless otherwise specified.

| PARAMETERS | TEST CONDITIONS | TEST LEVEL | SPT7851 | | | UNITS |
|-------------------------------------|-----------------------|------------|--------------|--------------|---------|---------------|
| | | | MIN | TYP | MAX | |
| Dynamic Performance | | | | | | |
| Effective Number of Bits | | | | | | |
| $f_{IN} = 5.0\text{ MHz}$ | | VI | 9.0 | 9.3 | | Bits |
| $f_{IN} = 10.0\text{ MHz}$ | | V | | 9.0 | | Bits |
| Signal-To-Noise Ratio | | | | | | |
| $f_{IN} = 5.0\text{ MHz}$ | | VI | 57 | 58 | | dB |
| $f_{IN} = 10.0\text{ MHz}$ | | V | | 58 | | dB |
| Total Harmonic Distortion | | | | | | |
| $f_{IN} = 5.0\text{ MHz}$ | | VI | | -68 | -61 | dB |
| $f_{IN} = 10.0\text{ MHz}$ | | V | | -60 | | dB |
| Signal-To-Noise and Distortion | | | | | | |
| $f_{IN} = 5\text{ MHz}$ | | VI | 56 | 58 | | dB |
| $f_{IN} = 10\text{ MHz}$ | | V | | 56 | | dB |
| Spurious Free Dynamic Range | | | | | | |
| $f_{IN} = 5.0\text{ MHz}$ | | VI | 62 | 70 | | dB |
| $f_{IN} = 10.0\text{ MHz}$ | | V | | 61 | | dB |
| Differential Phase | | V | | 0.2 | | Degrees |
| Differential Gain | | V | | 0.5 | | % |
| Digital Inputs | | | | | | |
| Logic 1 Voltage | | VI | 80% V_{DD} | | | |
| Logic 0 Voltage | | VI | | 20% V_{DD} | | |
| Maximum Input Current Low | $V_{IN} = \text{GND}$ | VI | | | ± 1 | μA |
| Maximum Input Current High | $V_{IN} = V_{DD}$ | VI | | | ± 1 | μA |
| Input Capacitance | | V | | 1.8 | | pF |
| Digital Outputs | | | | | | |
| Logic 1 Voltage | $I_O = -2\text{ mA}$ | VI | 85% V_{DD} | 95% V_{DD} | | V |
| Logic 0 Voltage | $I_O = +2\text{ mA}$ | VI | | 0.1 | 0.4 | V |
| CLK to Output Delay Time (t_D) | | IV | 4 | 8 | 12 | ns |
| Power Supply Requirements | | | | | | |
| Supply Voltages | | | | | | |
| $V_{DD1}, V_{DD2}, V_{DD3}$ | | IV | 2.8 | 3.3 | 3.6 | V |
| Supply Current | | | | | | |
| I_{DD} | | VI | | 24 | 30 | mA |
| Power Dissipation | | VI | | 79 | 100 | mW |
| Power Supply Rejection Ratio (PSRR) | | V | | 67 | | dB |

TEST LEVEL CODES

All electrical characteristics are subject to the following conditions: All parameters having min/max specifications are guaranteed. The Test Level column indicates the specific device testing actually performed during production and Quality Assurance inspection. Any blank section in the data column indicates that the specification is not tested at the specified condition.

TEST LEVEL TEST PROCEDURE

- I 100% production tested at the specified temperature.
- II 100% production tested at $T_A = +25\text{ }^\circ\text{C}$, and sample tested at the specified temperatures.
- III QA sample tested only at the specified temperatures.
- IV Parameter is guaranteed (but not tested) by design and characterization data.
- V Parameter is a typical value for information purposes only.
- VI 100% production tested at $T_A = +25\text{ }^\circ\text{C}$. Parameter is guaranteed over specified temperature range.

TYPICAL PERFORMANCE CHARACTERISTICS

THD, SNR, SINAD vs Input Frequency

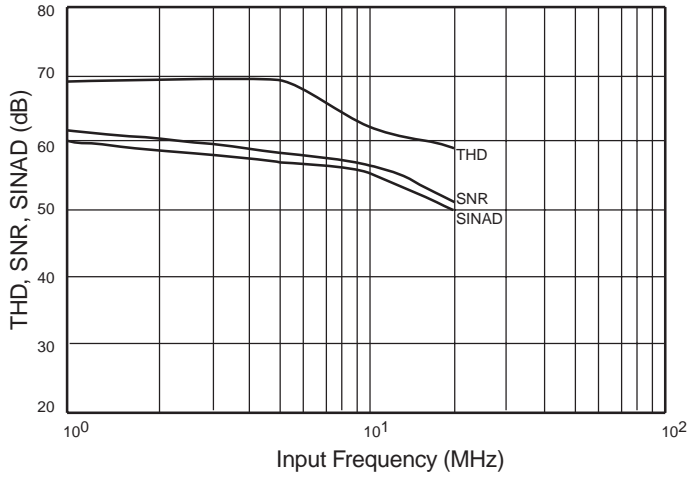

THD, SNR, SINAD vs Sample Rate

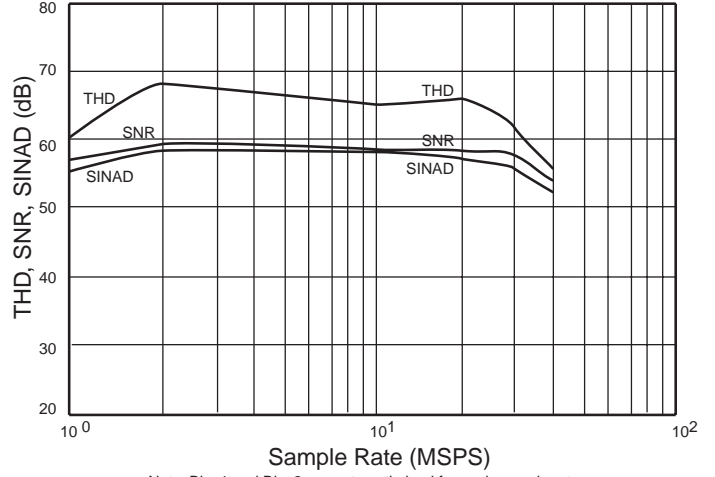

THD, SNR, SINAD vs Temperature

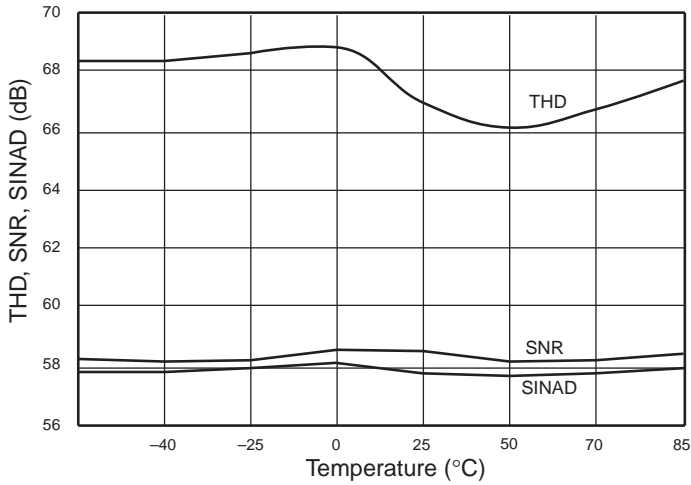

Power Dissipation vs Sample Rate

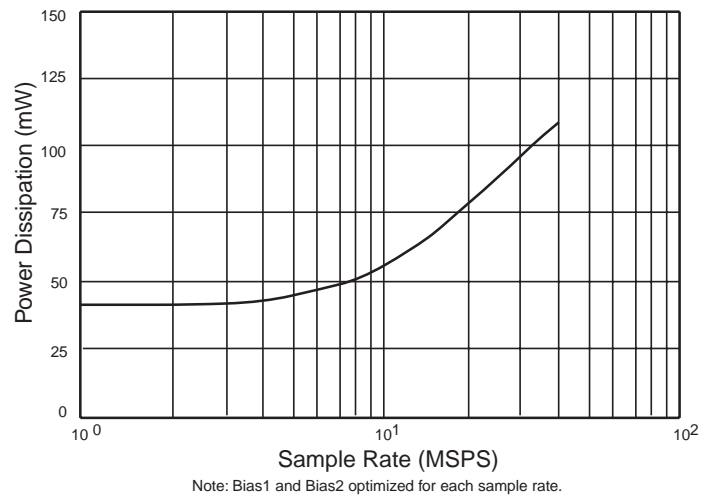

Bias 1 Voltage vs Bias 1 Current

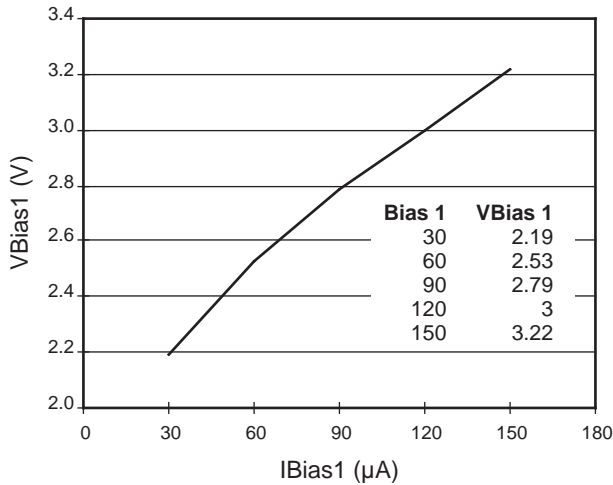

Bias 2 Voltage vs Bias 2 Current

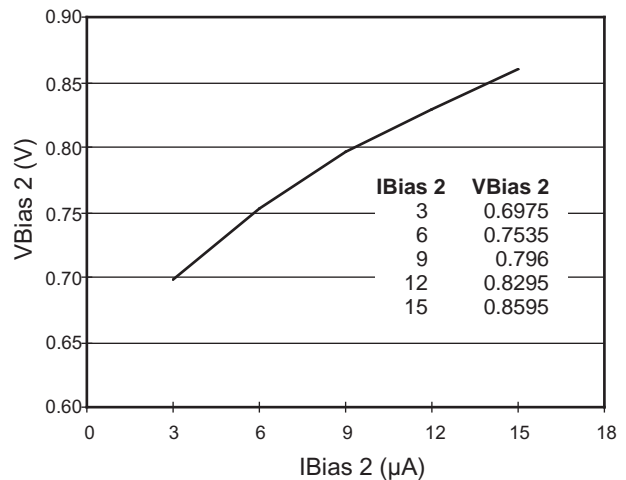
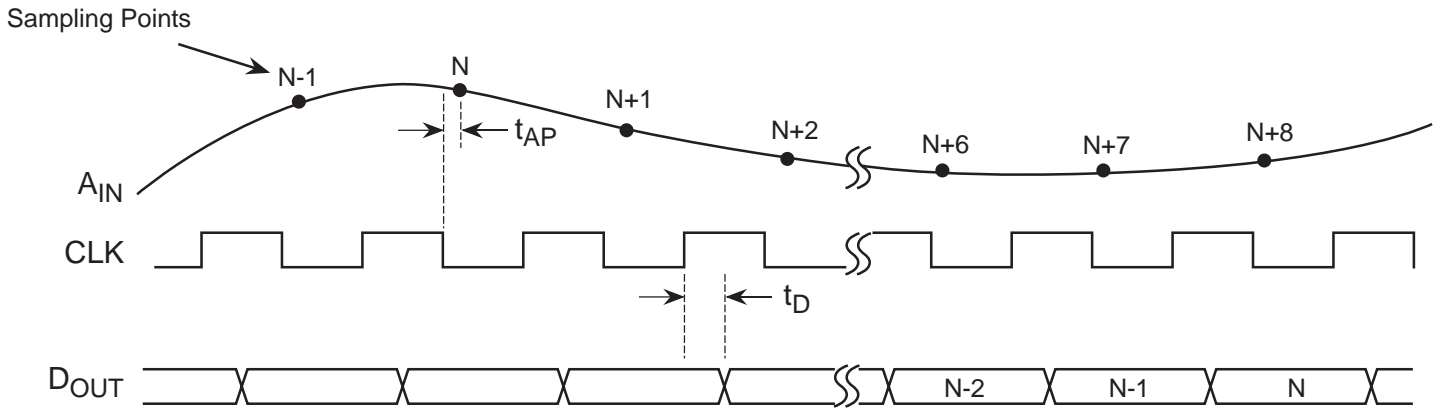

Figure 1 – Timing Diagram



GENERAL DESCRIPTION

The SPT7851 is an ultra-low power, 10-bit, 20 MSPS ADC. It has a pipelined architecture and incorporates digital error correction of all 10 bits. This error correction ensures good linearity performance for input frequencies up to Nyquist. The inputs are fully differential, making the device insensitive to system-level noise. This device can also be used in a single-ended mode. (See analog input section.) With the power dissipation roughly proportional to the sampling rate, this device is ideal for very low power applications in the range of 1 to 20 MSPS.

TYPICAL INTERFACE CIRCUIT

The SPT7851 requires few external components to achieve the stated operation and performance. Figure 2 shows the typical interface requirements when using the SPT7851 in normal circuit operation. The following sections provide a description of the functions and outline critical performance criteria to consider for achieving the optimal device performance.

Figure 2 – Typical Interface Circuit

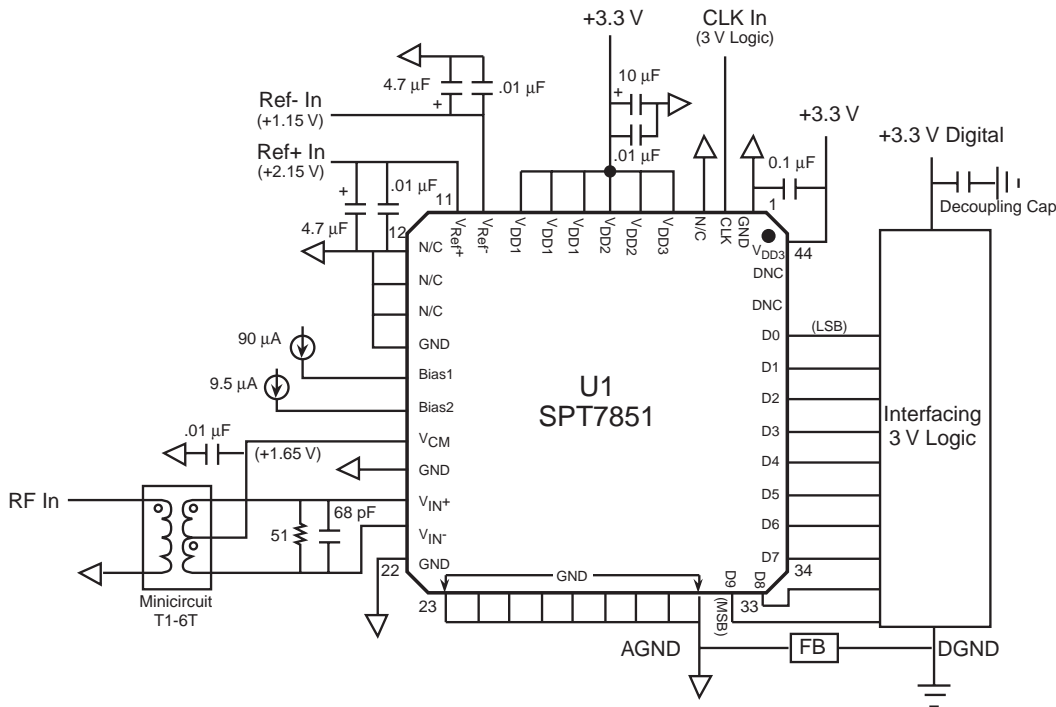

Note: 1. All VDD1, VDD2 and VDD3 should be tied together.
 2. FB = Ferrite Bead; must be placed as close to U1 as possible.

ANALOG INPUT

The input of the SPT7851 can be configured in various ways depending on if a single-ended or differential, AC- or DC-coupled input is desired.

The AC coupled input is most conveniently implemented using a transformer with a center tapped secondary winding. The center tap is connected to the V_{CM} pin as shown in figure 2. To obtain low distortion, it is important that the selected transformer does not exhibit core saturation at the full-scale voltage. Proper termination of the input is important for input signal purity. A small capacitor across the inputs attenuates kickback noise from the internal sample and hold.

Figure 3 illustrates a solution (based on operational amplifiers) that can be used if a DC-coupled single-ended input is desired. The selection criteria of the buffer op-amps is as follows:

- Open loop gain >75 dB
- Gain bandwidth product >50 MHz
- Total Harmonic Distortion ≤ -75 dB
- Signal-to-Noise Ratio >75 dB

Figure 3 – DC-Coupled Single-Ended to Differential Conversion (power supplies and bypassing are not shown)

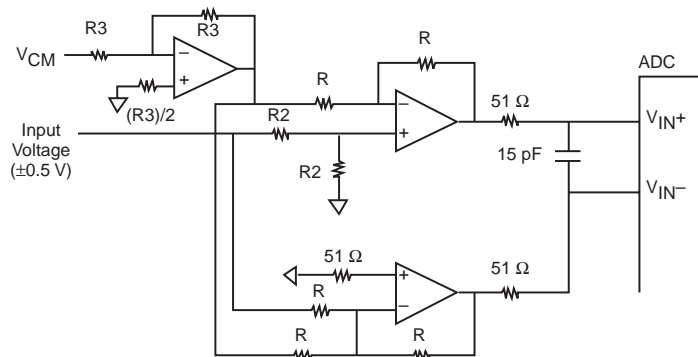

POWER SUPPLIES AND GROUNDING

The SPT7851 is operated from a single power supply in the range of 2.8 to 3.6 volts. Nominal operation is suggested to be 3.3 volts. All power supply pins should be bypassed as close to the package as possible. The analog and digital grounds should be connected together with a ferrite bead as shown in the typical interface circuit and as close to the ADC as possible.

REFERENCES

The SPT7851 has a differential analog input. The voltages applied to the V_{REF+} and V_{REF-} pins determine the input voltage range and are equal to $\pm(V_{REF+} - V_{REF-})$. This voltage range will be symmetrical about the common mode voltage. Externally generated reference voltages must be connected to these pins. (See figure 2, Typical Interface Circuit.) For best performance, these voltages should be symmetrical about the midpoint of the supply voltage.

COMMON MODE VOLTAGE REFERENCE CIRCUIT

The SPT7851 has an on-board common mode voltage reference circuit (V_{CM}). It is typically one-half of the supply voltage and can drive loads of up to 20 μ A. This circuit is commonly used to drive the center tap of the RF transformer in fully differential applications. For single-ended applications, this output can be used to provide the level shifting required for the single-to-differential converter conversion circuit.

BIAS CURRENT CIRCUITS

The bias currents suggested (Bias 1 and Bias 2 in figure 2) optimize device performance for the stated sample rate of 20 MSPS. To achieve the best dynamic performance when operating the device at sample rates other than 20 MSPS, the bias current levels should be adjusted. Table I shows the settings for Bias 1 and Bias 2 for selected sample rates. The “Bias Voltage vs Bias Current” graphs on page 4 show the relationship between the bias current and the bias voltage. Please refer to the application note for more information.

Table I – Sample Rate Settings

| Sample Rate (MHz) | Bias 1 (μ A) | Bias 2 (μ A) |
|-------------------|-------------------|-------------------|
| 1 | 30 | 3.0 |
| 5 | 50 | 6.0 |
| 10 | 70 | 7.5 |
| 20 | 90 | 9.5 |

CLOCK

The SPT7851 accepts a low voltage CMOS logic level at the CLK input. The duty cycle of the clock should be kept as close to 50% as possible. Because consecutive stages in the ADC are clocked in opposite phase to each other, a non-50% duty cycle reduces the settling time available for every other stage and thus could potentially cause a degradation of dynamic performance.

For optimal performance at high input frequencies, the clock should have low jitter and fast edges. The rise/fall times should be kept shorter than 2 ns. Overshoot and undershoot should be avoided. Clock jitter causes the noise floor to rise proportional to the input frequency. Because jitter can be caused by crosstalk on the PC board, it is recommended that the clock trace be kept as short as possible and standard transmission line practices be followed.

DIGITAL OUTPUTS

The digital output data appears in an offset binary code at 3.3 V CMOS logic levels. A negative full scale input results in an all zeros output code (000...0). A positive full scale

input results in an all 1's code (111...1). The output data is available 7.5 clock cycles after the data is sampled. The input signal is sampled on the high to low transition of the input clock. Output data should be latched on the low to high clock transition as shown in figure 1, the Timing Diagram. The output data is invalid for the first 20 clock cycles after the device is powered up.

EVALUATION BOARD

The EB7851 Evaluation Board is available to aid designers in demonstrating the full performance capability of the SPT7851. The board includes an on-board clock driver, adjustable voltage references, adjustable bias current circuits, single-to-differential input buffers with adjustable levels, a single-to-differential transformer (1:1), digital output buffers and 3.3/5 V adjustable logic outputs. An application note (AN7851) is also available which describes the operation of the evaluation board and provides an example of the recommended power and ground layout and signal routing. Contact the factory for price and availability.

PACKAGE OUTLINE

44L TQFP

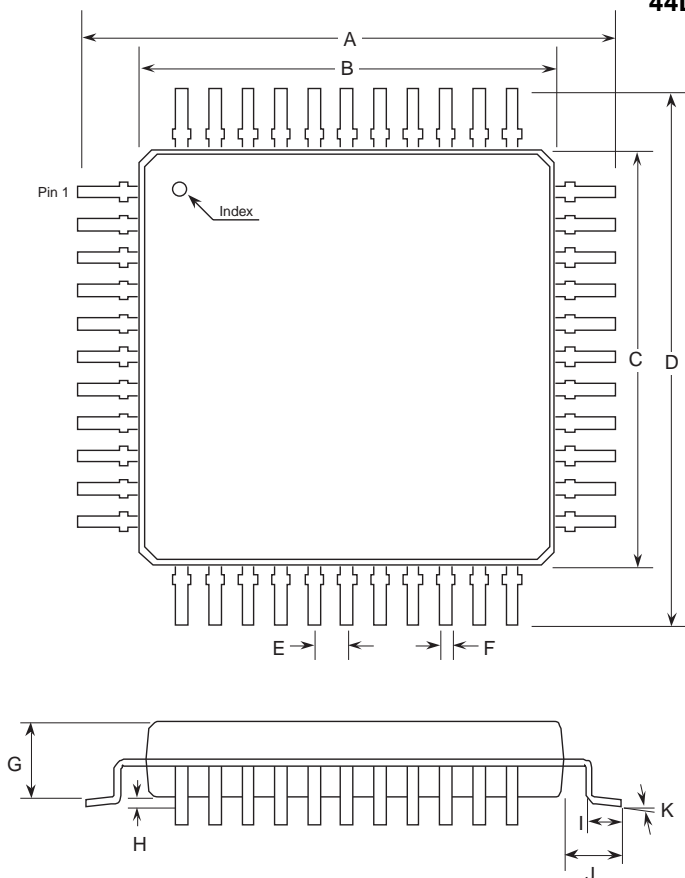

| SYMBOL | INCHES | | MILLIMETERS | |
|--------|-----------|-------|-------------|-------|
| | MIN | MAX | MIN | MAX |
| A | 0.472 Typ | | 12.00 Typ | |
| B | 0.394 Typ | | 10.00 Typ | |
| C | 0.394 Typ | | 10.00 Typ | |
| D | 0.472 Typ | | 12.00 Typ | |
| E | 0.031 Typ | | 0.80 Typ | |
| F | 0.012 | 0.018 | 0.300 | 0.45 |
| G | 0.053 | 0.057 | 1.35 | 1.45 |
| H | 0.002 | 0.006 | 0.05 | 0.15 |
| I | 0.018 | 0.030 | 0.450 | 0.750 |
| J | 0.039 Typ | | 1.00 Typ | |
| K | 0-7° | | 0-7° | |

PIN ASSIGNMENTS

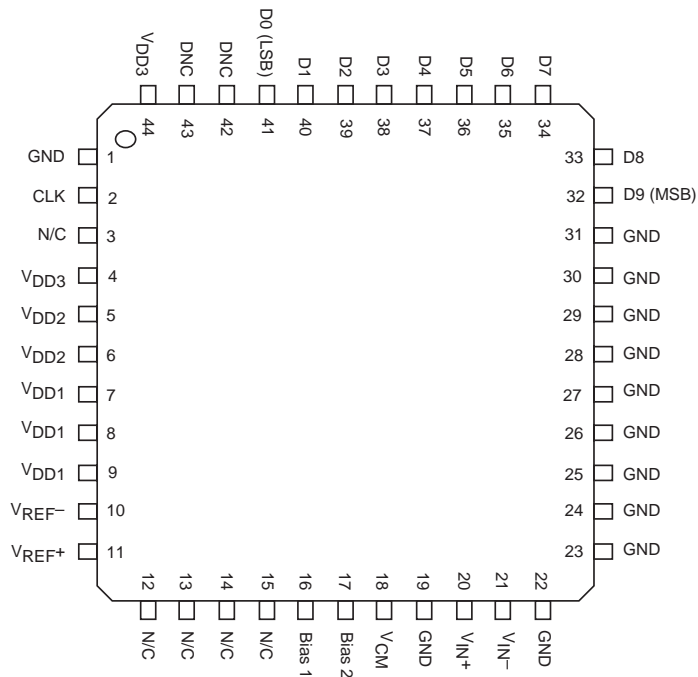

PIN FUNCTIONS

| Name | Function |
|-------------------------|---|
| V_{IN+} , V_{IN-} | Analog Inputs |
| V_{REF+} , V_{REF-} | External Reference Inputs |
| CLK | Input Clock |
| V_{CM} | Common Mode Output Voltage (1.65 V typ) |
| Bias 1 | Bias Current (90 μ A typ) |
| Bias 2 | Bias Current (9.5 μ A typ) |
| D0 – D9 | Digital Outputs (D0 = LSB) |
| GND | Analog Ground |
| V_{DD1} | Analog Power Supply |
| V_{DD2} | Digital Power Supply |
| V_{DD3} | Digital Output Power Supply |
| N/C | No Connect Pins. Recommended to connect to analog ground. |
| DNC | Do Not Connect Pins; leave floating. |

ORDERING INFORMATION

| PART NUMBER | TEMPERATURE RANGE | PACKAGE TYPE |
|-------------|-------------------|--------------|
| SPT7851SIT | -40 to +85 °C | 44L TQFP |

Signal Processing Technologies, Inc. reserves the right to change products and specifications without notice. Permission is hereby expressly granted to copy this literature for informational purposes only. Copying this material for any other use is strictly prohibited.

WARNING – LIFE SUPPORT APPLICATIONS POLICY – SPT products should not be used within Life Support Systems without the specific written consent of SPT. A Life Support System is a product or system intended to support or sustain life which, if it fails, can be reasonably expected to result in significant personal injury or death.

Signal Processing Technologies believes that ultrasonic cleaning of its products may damage the wire bonding, leading to device failure. It is therefore not recommended, and exposure of a device to such a process will void the product warranty.