

### FEATURES

- Monolithic
- 12-Bit 20 MSPS Converter
- 66 dB SNR @1 MHz Input
- On-Chip Track/Hold
- Bipolar  $\pm 2.0$  V Analog Input
- Low Power (1.1 W Typical)
- 5 pF Input Capacitance
- TTL Outputs

### GENERAL DESCRIPTION

The SPT7921 A/D converter is the industry's first 12-bit monolithic analog-to-digital converter capable of sample rates greater than 20 MSPS. On board input buffer and track/hold function assures excellent dynamic performance without the need for external components. Drive requirement problems are minimized with an input capacitance of only 5 pF.

Logic inputs and outputs are TTL. An overrange output signal is provided to indicate overflow conditions. Output data

### APPLICATIONS

- Radar Receivers
- Professional Video
- Instrumentation
- Medical Imaging
- Electronic Warfare
- Digital Communications
- Digital Spectrum Analyzers
- Electro-Optics

format is straight binary. Power dissipation is very low at only 1.1 watts with power supply voltages of +5.0 and -5.2 volts. The SPT7921 also provides a wide input voltage range of  $\pm 2.0$  volts.

The SPT7921 is available in 32-lead ceramic sidebraced DIP and 44-lead cerquad packages over the commercial temperature range. Consult the factory for availability of die, military temperature and /883 versions.

### BLOCK DIAGRAM

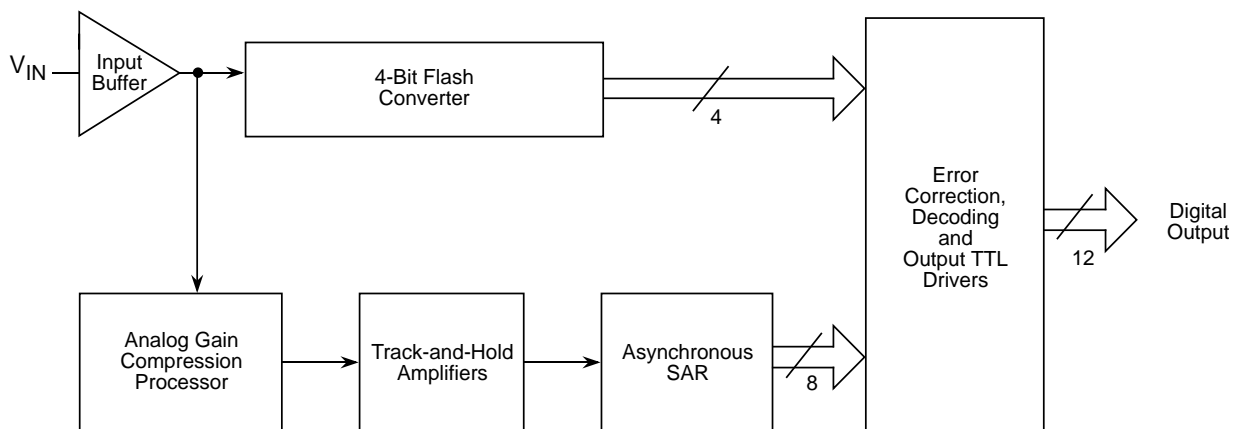

**Signal Processing Technologies, Inc.**

4755 Forge Road, Colorado Springs, Colorado 80907, USA

Phone: (719) 528-2300 FAX: (719) 528-2370

## ABSOLUTE MAXIMUM RATINGS (Beyond which damage may occur)<sup>1</sup> 25 °C

### Supply Voltages

|                       |      |
|-----------------------|------|
| V <sub>CC</sub> ..... | +6 V |
| V <sub>EE</sub> ..... | -6 V |

### Input Voltages

|   |   |
|---|---|
| Analog Input .....                      | V <sub>FB</sub> ≤ V <sub>IN</sub> ≤ V <sub>FT</sub> |
| V <sub>FT</sub> , V <sub>FB</sub> ..... | +3.0 V, -3.0 V                                      |
| Reference Ladder Current .....          | 12 mA   |
| CLK IN .....                            | V <sub>CC</sub>                                     |

### Output

|                       |             |
|-----------------------|-------------|
| Digital Outputs ..... | 0 to -30 mA |
|-----------------------|-------------|

### Temperature

|  |                |
|--|----------------|
| Operating Temperature .....                    | 0 to +70 °C    |
| Junction Temperature .....                     | +175 °C        |
| Lead Temperature, (soldering 10 seconds) ..... | +300 °C        |
| Storage Temperature .....                      | -65 to +150 °C |

**Note:** 1. Operation at any Absolute Maximum Rating is not implied. See Electrical Specifications for proper nominal applied conditions in typical applications.

## ELECTRICAL SPECIFICATIONS

T<sub>A</sub>=T<sub>MIN</sub> to T<sub>MAX</sub>, V<sub>CC</sub>=+5.0 V, V<sub>EE</sub>=-5.2 V, DV<sub>CC</sub>=+5.0 V, V<sub>IN</sub>=±2.0 V, V<sub>SB</sub>=-2.0 V, V<sub>ST</sub>=+2.0 V, f<sub>CLK</sub>=20 MHz, 50% clock duty cycle, unless otherwise specified.

| PARAMETERS                                | TEST CONDITIONS                                      | TEST LEVEL | SPT7921 |            |     | UNITS       |
|---|--|------------|---------|------------|-----|-------------|
|   |  |            | MIN     | TYP        | MAX |             |
| Resolution                                |  |            | 12      |            |     | Bits        |
| DC Accuracy                               | +25 °C   |            |         |            |     |             |
| Integral Nonlinearity                     | ± Full Scale   | V          |         | ±2.0       |     | LSB         |
| Differential Nonlinearity                 | 100 kHz Sample Rate                                  | V          |         | ±0.8       |     | LSB         |
| No Missing Codes                          |  | VI         |         | Guaranteed |     |             |
| Analog Input                              | f <sub>CLK</sub> =1 MHz                              |            |         |            |     |             |
| Input Voltage Range                       |  | VI         |         | ±2.0       |     | V           |
| Input Bias Current                        | T <sub>A</sub> =+25 °C                               | I          |         | 30         | 60  | µA          |
| Input Resistance                          | T <sub>A</sub> =+25 °C, V <sub>IN</sub> =0 V         | I          | 100     | 300        |     | kΩ          |
| Input Capacitance                         |  | V          |         | 5          |     | pF          |
| Input Bandwidth                           | 3 dB Small Signal                                    | V          |         | 120        |     | MHz         |
| +FS Error                                 |  | V          |         | ±5.0       |     | LSB         |
| -FS Error                                 |  | V          |         | ±5.0       |     | LSB         |
| Reference Input                           | f <sub>CLK</sub> =1 MHz                              |            |         |            |     |             |
| Reference Ladder Resistance               |  | VI         | 500     | 800        |     | Ω           |
| Reference Ladder Tempco                   |  | V          |         | 0.8        |     | Ω/°C        |
| Timing Characteristics                    |  |            |         |            |     |             |
| Maximum Conversion Rate                   |  | VI         | 20      |            |     | MHz         |
| Overvoltage Recovery Time                 |  | V          |         | 20         |     | ns          |
| Pipeline Delay (Latency)                  |  | IV         |         |            | 1   | Clock Cycle |
| Output Delay                              | T <sub>A</sub> =+25 °C                               | V          |         | 14         | 18  | ns          |
| Aperture Delay Time                       | T <sub>A</sub> =+25 °C                               | V          |         | 1          |     | ns          |
| Aperture Jitter Time                      | T <sub>A</sub> =+25 °C                               | V          |         | 5          |     | ps-RMS      |
| Dynamic Performance                       |  |            |         |            |     |             |
| Effective Number of Bits                  |  |            |         |            |     |             |
| f <sub>IN</sub> =500 kHz                  |  |            |         | 10.2       |     | Bits        |
| f <sub>IN</sub> =1.0 MHz                  |  |            |         | 10.0       |     | Bits        |
| f <sub>IN</sub> =3.58 MHz                 |  |            |         | 9.5        |     | Bits        |
| Signal-To-Noise Ratio (without Harmonics) |  |            |         |            |     |             |
| f <sub>IN</sub> =500 kHz                  | T <sub>A</sub> =+25 °C                               | I          | 64      | 67         |     | dB          |
|   | T <sub>A</sub> =T <sub>MIN</sub> to T <sub>MAX</sub> | IV         | 58      | 61         |     | dB          |
| f <sub>IN</sub> =1 MHz                    | T <sub>A</sub> =+25 °C                               | I          | 64      | 66         |     | dB          |
|   | T <sub>A</sub> =T <sub>MIN</sub> to T <sub>MAX</sub> | IV         | 58      | 60         |     | dB          |
| f <sub>IN</sub> =3.58 MHz                 | T <sub>A</sub> =+25 °C                               | I          | 62      | 64         |     | dB          |
|   | T <sub>A</sub> =T <sub>MIN</sub> to T <sub>MAX</sub> | IV         | 58      | 60         |     | dB          |

## ELECTRICAL SPECIFICATIONS

$T_A = T_{MIN}$  to  $T_{MAX}$ ,  $V_{CC} = +5.0$  V,  $V_{EE} = -5.2$  V,  $DV_{CC} = +5.0$  V,  $V_{IN} = \pm 2.0$  V,  $V_{SB} = -2.0$  V,  $V_{ST} = +2.0$  V,  $f_{CLK} = 20$  MHz, 50% clock duty cycle, unless otherwise specified.

| PARAMETERS                               | TEST CONDITIONS                     | TEST LEVEL | SPT7921 |      |       | UNITS  |
|--|-------------------------------------|------------|---------|------|-------|--------|
|  |                                     |            | MIN     | TYP  | MAX   |        |
| Dynamic Performance                      |                                     |            |         |      |       |        |
| Harmonic Distortion                      |                                     |            |         |      |       |        |
| $f_{IN} = 500$ kHz                       | $T_A = +25$ °C                      | I          | 63      | 66   |       | dB     |
|  | $T_A = T_{MIN}$ to $T_{MAX}$        | IV         | 59      | 62   |       | dB     |
| $f_{IN} = 1.0$ MHz                       | $T_A = +25$ °C                      | I          | 63      | 65   |       | dB     |
|  | $T_A = T_{MIN}$ to $T_{MAX}$        | IV         | 59      | 61   |       | dB     |
| $f_{IN} = 3.58$ MHz                      | $T_A = +25$ °C                      | I          | 59      | 61   |       | dB     |
|  | $T_A = T_{MIN}$ to $T_{MAX}$        | IV         | 57      | 59   |       | dB     |
| Signal-to-Noise and Distortion           |                                     |            |         |      |       |        |
| $f_{IN} = 500$ kHz                       | $T_A = +25$ °C                      | I          | 60      | 63   |       | dB     |
|  | $T_A = T_{MIN}$ to $T_{MAX}$        | IV         | 55      | 58   |       | dB     |
| $f_{IN} = 1.0$ MHz                       | $T_A = +25$ °C                      | I          | 60      | 62   |       | dB     |
|  | $T_A = T_{MIN}$ to $T_{MAX}$        | IV         | 55      | 57   |       | dB     |
| $f_{IN} = 3.58$ MHz                      | $T_A = +25$ °C                      | I          | 57      | 59   |       | dB     |
|  | $T_A = T_{MIN}$ to $T_{MAX}$        | IV         | 54      | 56   |       | dB     |
| Spurious Free Dynamic Range <sup>1</sup> | $T_A = +25$ °C                      | V          |         | 74   |       | dB     |
| Differential Phase <sup>2</sup>          | $T_A = +25$ °C                      | V          |         | 0.2  |       | Degree |
| Differential Gain <sup>2</sup>           | $T_A = +25$ °C                      | V          |         | 0.7  |       | %      |
| Digital Inputs                           |                                     |            |         |      |       |        |
| Logic 1 Voltage                          | $f_{CLK} = 1$ MHz<br>$T_A = +25$ °C | I          | 2.4     |      | 4.5   | V      |
| Logic 0 Voltage                          | $T_A = +25$ °C                      | I          |         |      | 0.8   | V      |
| Maximum Input Current Low                | $T_A = +25$ °C                      | I          | 0       | +5   | +20   | μA     |
| Maximum Input Current High               | $T_A = +25$ °C                      | I          | 0       | +5   | +20   | μA     |
| Pulse Width Low (CLK)                    |                                     | IV         | 20      |      |       | ns     |
| Pulse Width High (CLK)                   |                                     | IV         | 20      |      | 300   | ns     |
| Digital Outputs                          |                                     |            |         |      |       |        |
| Logic 1 Voltage                          | $f_{CLK} = 1$ MHz<br>$T_A = +25$ °C | I          | 2.4     |      |       | V      |
| Logic 0 Voltage                          | $T_A = +25$ °C                      | I          |         |      | 0.6   | V      |
| Power Supply Requirements                |                                     |            |         |      |       |        |
| Voltages                                 | $V_{CC}$                            | IV         | 4.75    | 5.0  | 5.25  | V      |
|  | $DV_{CC}$                           | IV         | 4.75    | 5.0  | 5.25  | V      |
|  | $-V_{EE}$                           | IV         | -4.95   | -5.2 | -5.45 | V      |
| Currents                                 | $I_{CC}$                            | I          |         | 135  | 150   | mA     |
|  | $D I_{CC}$                          | I          |         | 40   | 55    | mA     |
|  | $-I_{EE}$                           | I          |         | 45   | 70    | mA     |
| Power Dissipation                        | $T_A = +25$ °C                      | VI         |         | 1.1  | 1.3   | W      |
| Power Supply Rejection                   | 5 V $\pm$ 0.25 V, -5.2 $\pm$ 0.25 V | V          |         | 1.0  |       | LSB    |

Typical thermal impedances (unsoldered, in free air):

32L sidebraced DIP:

$$\theta_{ja} = +50 \text{ °C/W}$$

44L cerquad:

$$\theta_{ja} = +78 \text{ °C/W}$$

$$\theta_{ja} \text{ at 1 M/s airflow} = +58 \text{ °C/W}$$

$$\theta_{jc} = +3.3 \text{ °C/W}$$

<sup>1</sup> $f_{IN} = 1$  MHz.

<sup>2</sup> $f_{IN} = 3.58$  and  $4.35$  MHz.

## TEST LEVEL CODES

All electrical characteristics are subject to the following conditions:

All parameters having min/max specifications are guaranteed. The Test Level column indicates the specific device testing actually performed during production and Quality Assurance inspection. Any blank section in the data column indicates that the specification is not tested at the specified condition.

## TEST LEVEL

## TEST PROCEDURE

|     |   |
|-----|---|
| I   | 100% production tested at the specified temperature.  |
| II  | 100% production tested at $T_A = +25\text{ }^\circ\text{C}$ , and sample tested at the specified temperatures.          |
| III | QA sample tested only at the specified temperatures.  |
| IV  | Parameter is guaranteed (but not tested) by design and characterization data.   |
| V   | Parameter is a typical value for information purposes only.   |
| VI  | 100% production tested at $T_A = +25\text{ }^\circ\text{C}$ . Parameter is guaranteed over specified temperature range. |

Figure 1A: Timing Diagram

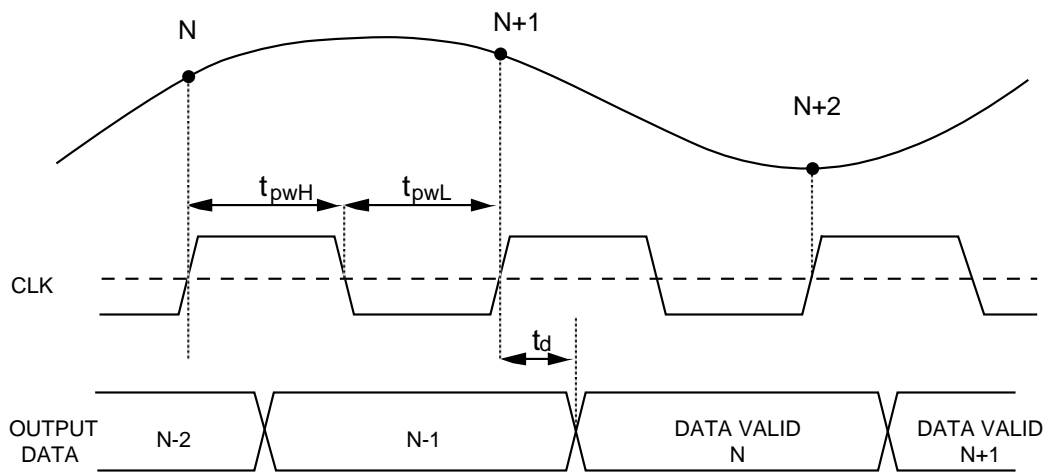

Figure 1B: Single Event Clock

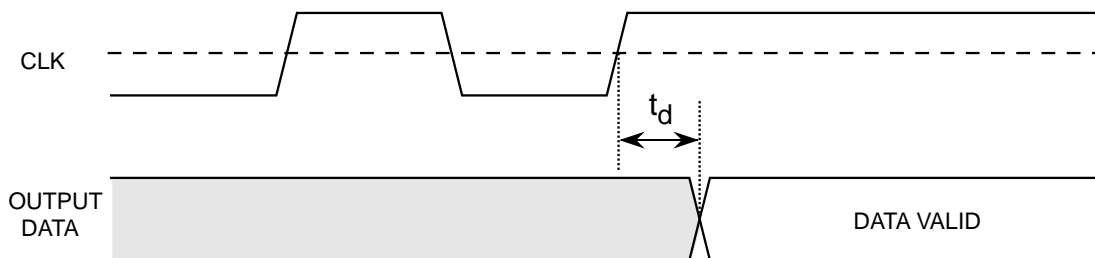

Table I - Timing Parameters

| PARAMETERS | DESCRIPTION                  | MIN | TYP | MAX | UNITS |
|------------|------------------------------|-----|-----|-----|-------|
| $t_d$      | CLK to Data Valid Prop Delay | -   | 14  | 18  | ns    |
| $t_{pwH}$  | CLK High Pulse Width         | 20  | -   | 300 | ns    |
| $t_{pwL}$  | CLK Low Pulse Width          | 20  | -   | -   | ns    |

## SPECIFICATION DEFINITIONS

### APERTURE DELAY

Aperture delay represents the point in time, relative to the rising edge of the CLOCK input, that the analog input is sampled.

### APERTURE JITTER

The variations in aperture delay for successive samples.

### DIFFERENTIAL GAIN (DG)

A signal consisting of a sine wave superimposed on various DC levels is applied to the input. Differential gain is the maximum variation in the sampled sine wave amplitudes at these DC levels.

### DIFFERENTIAL PHASE (DP)

A signal consisting of a sine wave superimposed on various DC levels that is applied to the input. Differential phase is the maximum variation in the sampled sine wave phases at these DC levels.

### EFFECTIVE NUMBER OF BITS (ENOB)

$SINAD = 6.02N + 1.76$ , where N is equal to the effective number of bits.

$$N = \frac{SINAD - 1.76}{6.02}$$

### +/- FULL-SCALE ERROR (GAIN ERROR)

Difference between measured full scale response [(+Fs) - (-Fs)] and the theoretical response (+4 V -2 LSBs) where the +FS (full scale) input voltage is defined as the output transition between 1-10 and 1-11 and the -FS input voltage is defined as the output transition between 0-00 and 0-01.

### INPUT BANDWIDTH

Small signal (50 mV) bandwidth (3 dB) of analog input stage.

### DIFFERENTIAL NONLINEARITY (DNL)

Error in the width of each code from its theoretical value. (Theoretical =  $V_{FS}/2^N$ )

### INTEGRAL NONLINEARITY (INL)

Linearity error refers to the deviation of each individual code (normalized) from a straight line drawn from -Fs through +Fs. The deviation is measured from the edge of each particular code to the true straight line.

### OUTPUT DELAY

Time between the clock's triggering edge and output data valid.

### OVERVOLTAGE RECOVERY TIME

The time required for the ADC to recover to full accuracy after an analog input signal 125% of full scale is reduced to 50% of the full-scale value.

### SIGNAL-TO-NOISE RATIO (SNR)

The ratio of the fundamental sinusoid power to the total noise power. Harmonics are excluded.

### SIGNAL-TO-NOISE AND DISTORTION (SINAD)

The ratio of the fundamental sinusoid power to the total noise and distortion power.

### TOTAL HARMONIC DISTORTION (THD)

The ratio of the total power of the first 64 harmonics to the power of the measured sinusoidal signal.

### SPURIOUS FREE DYNAMIC RANGE (SFDR)

The ratio of the fundamental sinusoidal amplitude to the single largest harmonic or spurious signal.

# PERFORMANCE CHARACTERISTICS

**SNR vs Input Frequency**

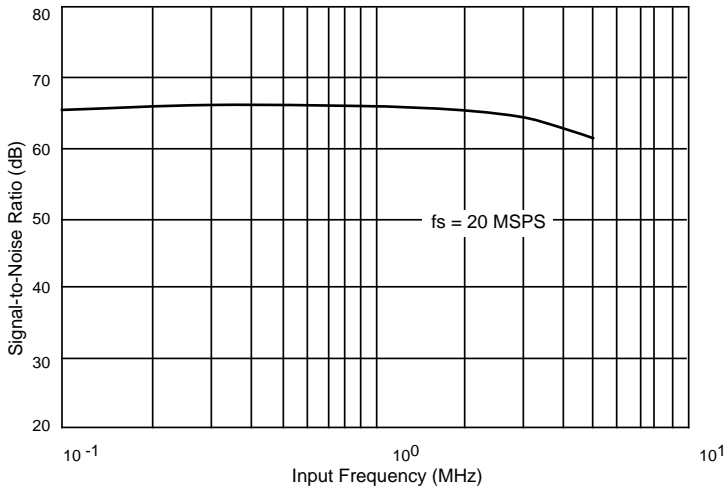

**THD vs Input Frequency**

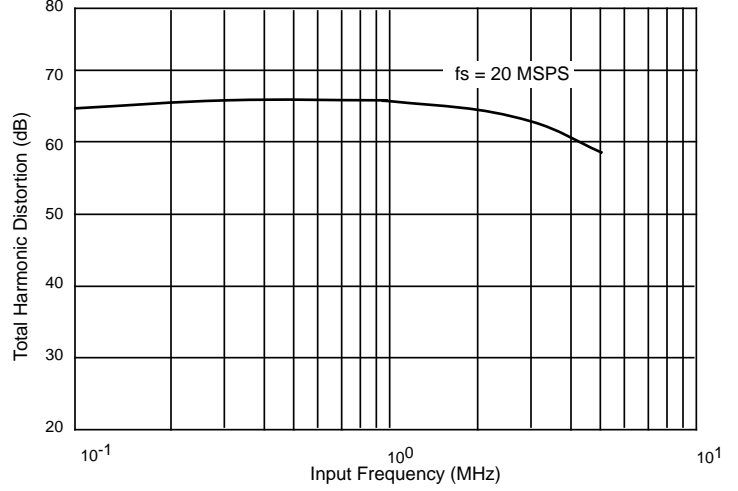

**SNR, THD, SINAD vs Sample Rate**

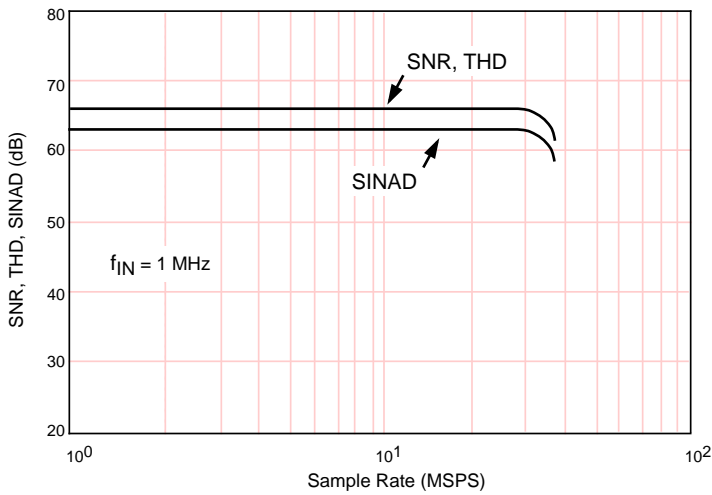

**SINAD vs Input Frequency**

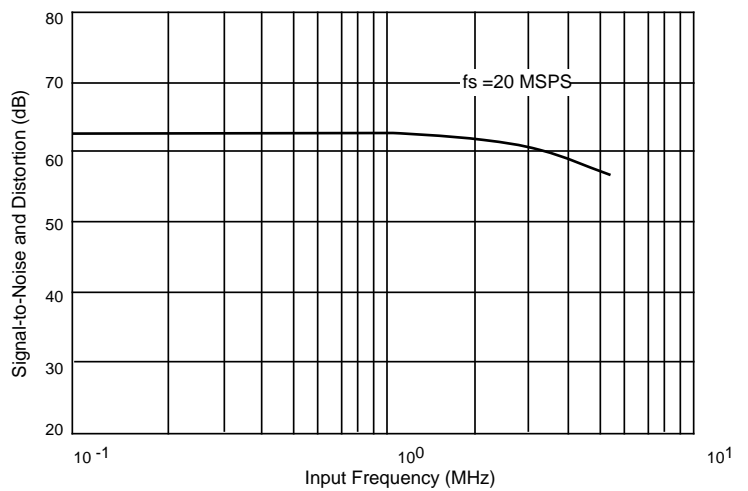

**SPT7921 Spectral Response**

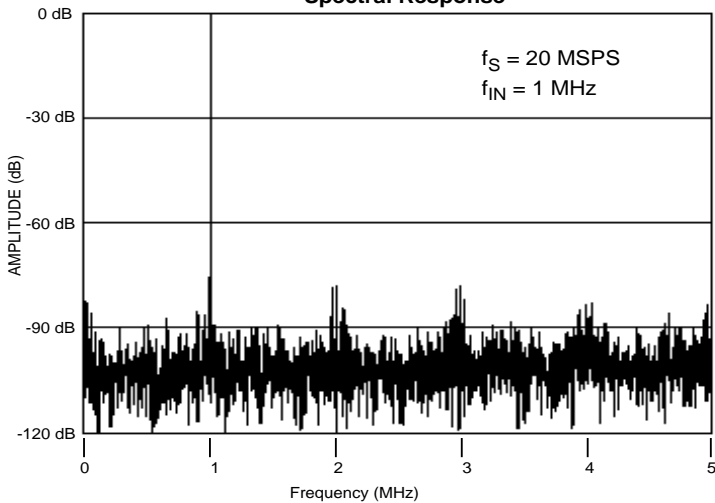

**SNR, THD, SINAD vs Temperature**

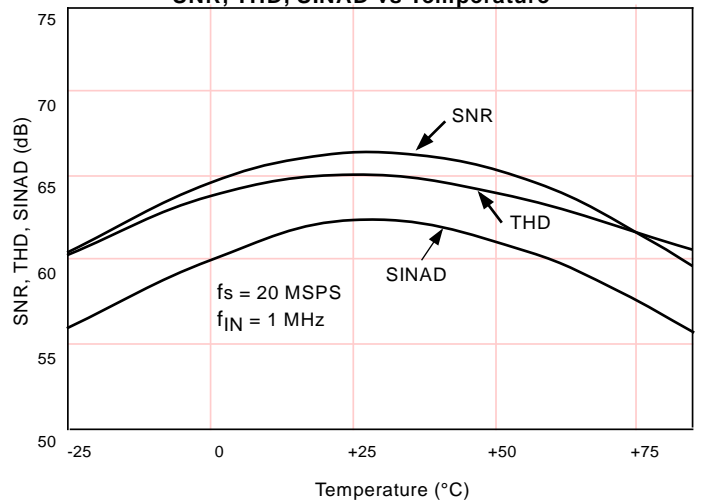

## TYPICAL INTERFACE CIRCUIT

The SPT7921 requires few external components to achieve the stated operation and performance. Figure 2 shows the typical interface requirements when using the SPT7921 in normal circuit operation. The following section provides a description of the pin functions and outlines critical performance criteria to consider for achieving the optimal device performance.

### POWER SUPPLIES AND GROUNDING

The SPT7921 requires -5.2 V and +5 V analog supply voltages. The +5 V supply is common to analog  $V_{CC}$  and digital  $DV_{CC}$ . A ferrite bead in series with each supply line is intended to reduce the transient noise injected into the analog  $V_{CC}$ . These beads should be connected as closely as possible to the device. The connection between the beads and the SPT7921 should not be shared with any other device. Each power supply pin should be bypassed as closely as possible to the device. Use  $0.1 \mu\text{F}$  for  $V_{EE}$  and  $V_{CC}$ , and  $0.01 \mu\text{F}$  for  $DV_{CC}$  (chip caps are preferred).

AGND and DGND are the two grounds available on the SPT7921. These two internal grounds are isolated on the device. The use of ground planes is recommended to achieve optimum device performance. DGND is needed for the  $DV_{CC}$  return path (40 mA typical) and for the return path for all digital output logic interfaces. AGND and DGND should be separated from each other and connected together only at the device through a ferrite bead.

A Schottky or hot carrier diode connected between AGND and  $V_{EE}$  is required. The use of separate power supplies between  $V_{CC}$  and  $DV_{CC}$  is not recommended due to potential power supply sequencing latch-up conditions. Using the recommended interface circuit shown in figure 2 will provide optimum device performance for the SPT7921.

### VOLTAGE REFERENCE

The SPT7921 requires the use of two voltage references:  $V_{FT}$  and  $V_{FB}$ .  $V_{FT}$  is the force for the top of the voltage reference ladder (+2.5 V typ),  $V_{FB}$  (-2.5 V typ) is the force for the bottom of the voltage reference ladder. Both voltages are applied across an internal reference ladder resistance of 800 ohms. The +2.5 V voltage source for reference  $V_{FT}$  must be current limited to 20 mA maximum if a different driving circuit is used in place of the recommended reference circuit shown in figures 2 and 3. In addition, there are five reference ladder taps ( $V_{ST}$ ,  $V_{RT1}$ ,  $V_{RT2}$ ,  $V_{RT3}$ , and  $V_{SB}$ ).  $V_{ST}$  is the sense for the top of the reference ladder (+2.0 V),  $V_{RT2}$  is the midpoint of the ladder (0.0 V typ) and  $V_{SB}$  is the sense for the bottom of the reference ladder (-2.0 V).  $V_{RT1}$  and  $V_{RT3}$  are quarter point ladder taps (+1.0 and -1.0 V typical, respectively). The voltages seen at  $V_{ST}$  and  $V_{SB}$  are the true full scale input voltages of the device when  $V_{FT}$  and  $V_{FB}$  are driven to the recommended voltages (+2.5 V and -2.5 V typical respectively).  $V_{ST}$  and  $V_{SB}$  should be used to monitor the actual full scale input voltage of the device.  $V_{RT1}$ ,  $V_{RT2}$  and  $V_{RT3}$  should not be driven to the expected ideal values as is commonly done with standard flash converters. When not being used, a decoupling capacitor of  $.01 \mu\text{F}$  connected to AGND from each tap is recommended to minimize high frequency noise injection.

Figure 2 - Typical Interface Circuit

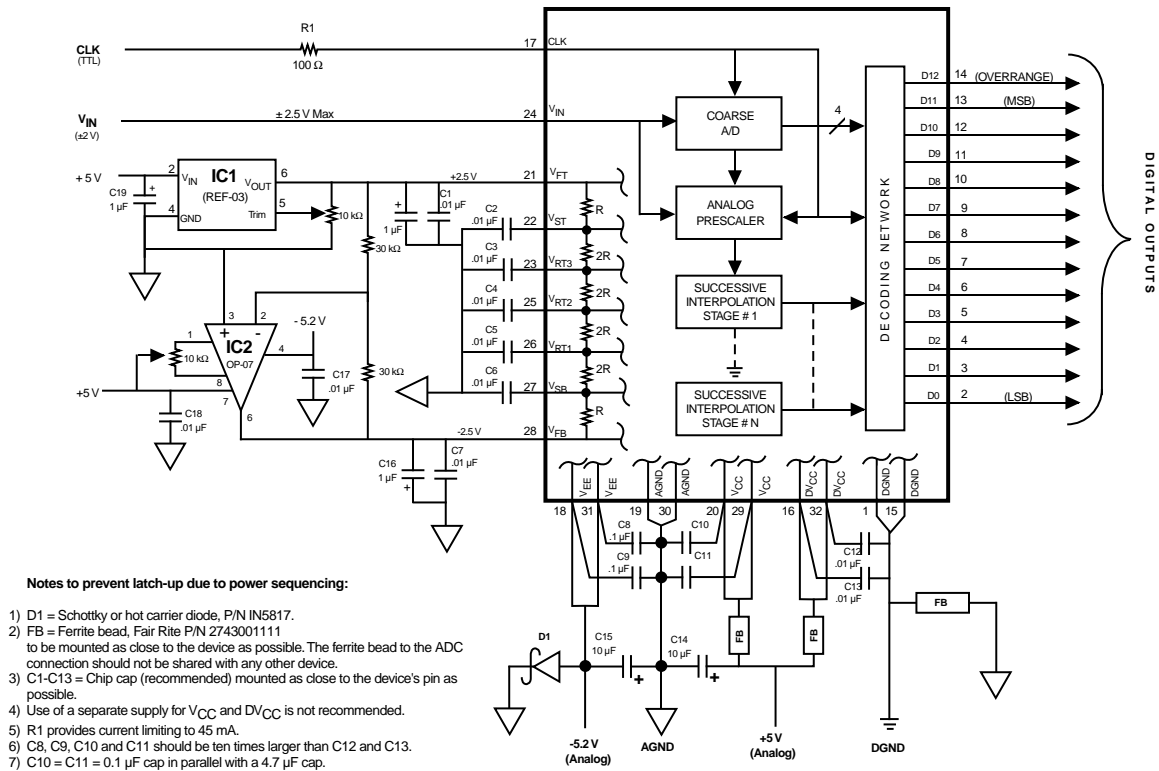

**Figure 3 - Analog Equivalent Input Circuit**

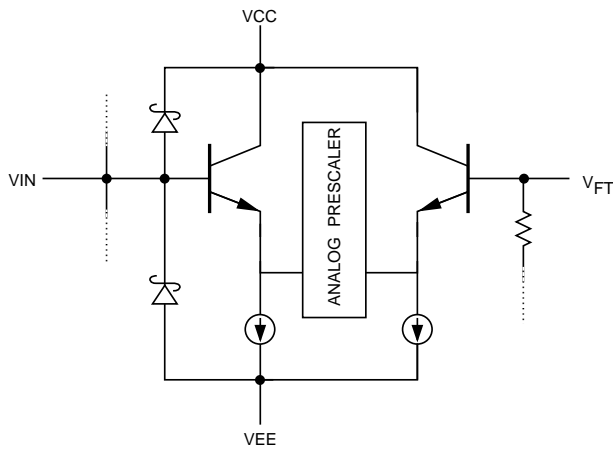

The analog input range will scale proportionally with respect to the reference voltage if a different input range is required. The maximum scaling factor for device operation is  $\pm 20\%$  of the recommended reference voltages of  $V_{FT}$  and  $V_{FB}$ . However, because the device is laser trimmed to optimize performance with  $\pm 2.5$  V references, the accuracy of the device will degrade if operated beyond a  $\pm 2\%$  range.

An example of a recommended reference driver circuit is shown in figure 2. IC1 is REF-03, the +2.5 V reference with a tolerance of 0.6% or  $\pm 0.015$  V. The potentiometer R1 is 10 k $\Omega$  and supports a minimum adjustable range of up to 150 mV. IC2 is recommended to be an OP-07 or equivalent device. R2 and R3 must be matched to within 0.1% with good TC tracking to maintain a 0.3 LSB matching between  $V_{FT}$  and  $V_{FB}$ . If 0.1% matching is not met, then potentiometer R4 can be used to adjust the  $V_{FB}$  voltage to the desired level. R1 and R4 should be adjusted such that  $V_{ST}$  and  $V_{SB}$  are exactly +2.0 V and -2.0 V respectively.

The following errors are defined:

$$\begin{aligned} +FS \text{ error} &= \text{top of ladder offset voltage} = \Delta(+FS - V_{ST}) \\ -FS \text{ error} &= \text{bottom of ladder offset voltage} = \Delta(-FS - V_{SB}) \end{aligned}$$

Where the +FS (full scale) input voltage is defined as the output 1 LSB above the transition of 1—10 and 1—11 and the -FS input voltage is defined as the output 1 LSB below the transition of 0—00 and 0—01.

**ANALOG INPUT**

$V_{IN}$  is the analog input. The full scale input range will be 80% of the reference voltage or  $\pm 2$  volts with  $V_{FB} = -2.5$  V and  $V_{FT} = +2.5$  V.

The drive requirements for the analog inputs are minimal when compared to conventional Flash converters due to the SPT7921's extremely low input capacitance of only 5 pF and very high input impedance of 300 k $\Omega$ . For example, for an input signal of  $\pm 2$  V p-p with an input frequency of 10 MHz, the peak output current required for the driving circuit is only 628  $\mu$ A.

**CLOCK INPUT**

The SPT7921 is driven from a single-ended TTL input (CLK). For optimal noise performance, the clock input slew rate should be a minimum of 6 ns. Because of this, the use of *fast* logic is recommended. The clock input duty cycle should be 50% where possible, but performance will not be degraded if kept within the range of 40-60%. However, in any case the clock pulse width (tpwH) must be kept at 300 ns maximum to ensure proper operation of the internal track and hold amplifier (see timing diagram). The analog input signal is latched on the rising edge of the CLK.

The clock input must be driven from fast TTL logic ( $V_{IH} \leq 4.5$  V,  $T_{RISE} < 6$  ns). In the event the clock is driven from a high current source, use a 100  $\Omega$  resistor in series to current limit to approximately 45 mA.

**DIGITAL OUTPUTS**

The format of the output data (D0-D11) is straight binary. (See table II.) The outputs are latched on the rising edge of CLK with a propagation delay of 14 ns (typ). There is a one clock cycle latency between CLK and the valid output data. (See timing diagram.)

**Table II - Output Data Information**

| ANALOG INPUT         | OVERRANGE D12 | OUTPUT CODE D11-DO |
|----------------------|---------------|--------------------|
| $> +2.0$ V + 1/2 LSB | 1             | 1111 1111 1111     |
| $+2.0$ V -1 LSB      | 0             | 1111 1111 1110     |
| 0.0 V                | 0             | 0000 0000 0000     |
| $-2.0$ V +1 LSB      | 0             | 0000 0000 0000     |
| $< -2.0$ V           | 0             | 0000 0000 0000     |

( $\emptyset$  indicates the flickering bit between logic 0 and 1).

The rise times and fall times of the digital outputs are not symmetrical. The propagation delay of the rise time is typically 14 ns and the fall time is typically 6 ns. (See figure 4.) The nonsymmetrical rise and fall times create approximately 8 ns of invalid data.



**Figure 4 - Digital Output Characteristics**

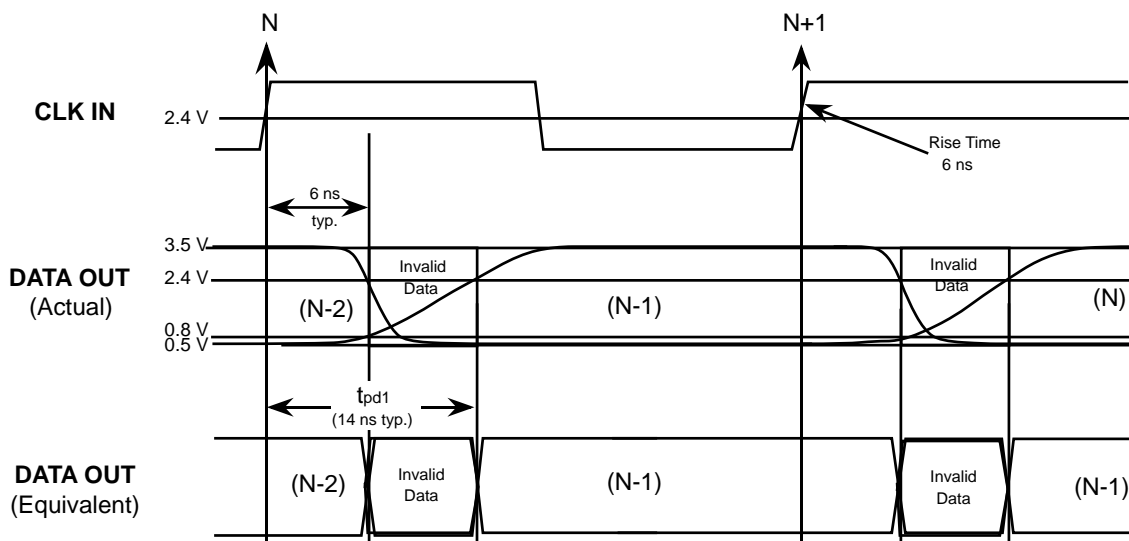

**OVERRANGE OUTPUT**

The overrange output (D12) is an indication that the analog input signal has exceeded the full scale input voltage by 1 LSB. When this condition occurs, the outputs will switch to logic 1s. All other data outputs are unaffected by this operation. This feature makes it possible to include the SPT7921 into higher resolution systems.

**EVALUATION BOARD**

The EB7921 evaluation board is available to aid designers in demonstrating the full performance of the SPT7921. This board includes a reference circuit, clock driver circuit, output data latches and an on-board reconstruction of the digital data. An application note (AN7921) describing the operation of this board as well as information on the testing of the SPT7921 is also available. Contact the factory for price and availability.

# PACKAGE OUTLINES

## 32-Lead Sidebraced

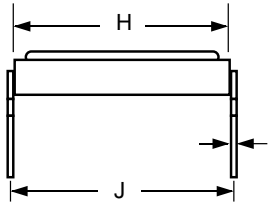
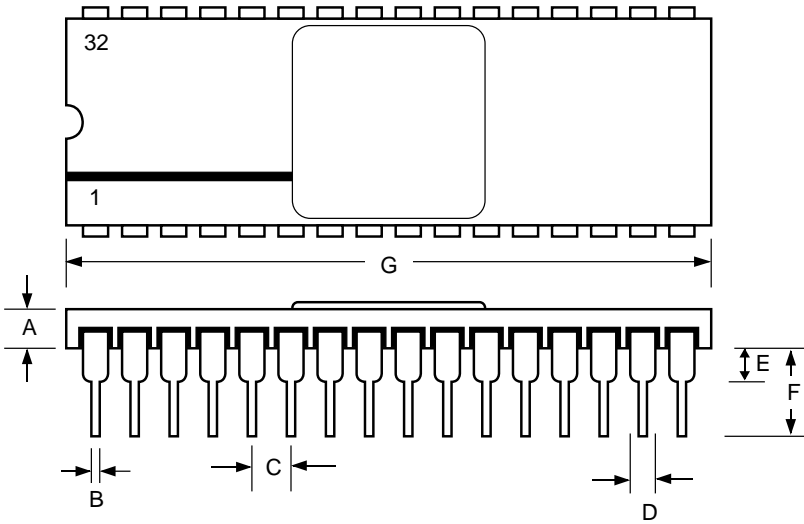

| SYMBOL | INCHES |          | MILLIMETERS |       |
|--------|--------|----------|-------------|-------|
|        | MIN    | MAX      | MIN         | MAX   |
| A      | 0.081  | 0.099    | 2.06        | 2.51  |
| B      | 0.016  | 0.020    | 0.41        | 0.51  |
| C      | 0.095  | 0.105    | 2.41        | 2.67  |
| D      |        | .050 typ |             | 1.27  |
| E      | 0.040  |          | 1.02        |       |
| F      | 0.175  | 0.225    | 4.45        | 5.72  |
| G      | 1.580  | 1.620    | 40.13       | 41.15 |
| H      | 0.585  | 0.605    | 14.86       | 15.37 |
| I      | 0.009  | 0.012    | 0.23        | 0.30  |
| J      | 0.600  | 0.620    | 15.24       | 15.75 |

## 44-Lead Cerquad

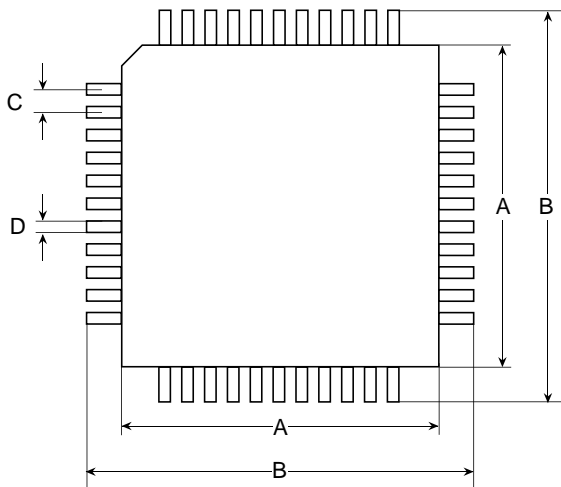

| SYMBOL | INCHES    |       | MILLIMETERS |       |
|--------|-----------|-------|-------------|-------|
|        | MIN       | MAX   | MIN         | MAX   |
| A      | 0.550 typ |       | 13.97 typ   |       |
| B      | 0.685     | 0.709 | 17.40       | 18.00 |
| C      | 0.037     | 0.041 | 0.94        | 1.04  |
| D      | 0.016 typ |       | 0.41 typ    |       |
| E      | 0.008 typ |       | 0.20 typ    |       |
| F      | 0.027     | 0.051 | 0.69        | 1.30  |
| G      | 0.006 typ |       | 0.15 typ    |       |
| H      | 0.080     | 0.150 | 2.03        | 3.81  |

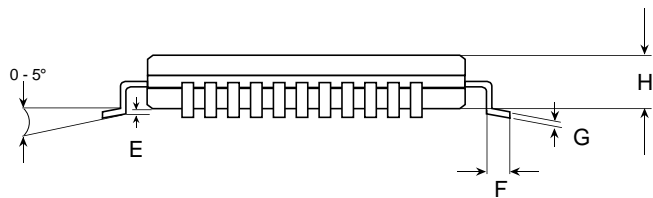

## PIN ASSIGNMENTS

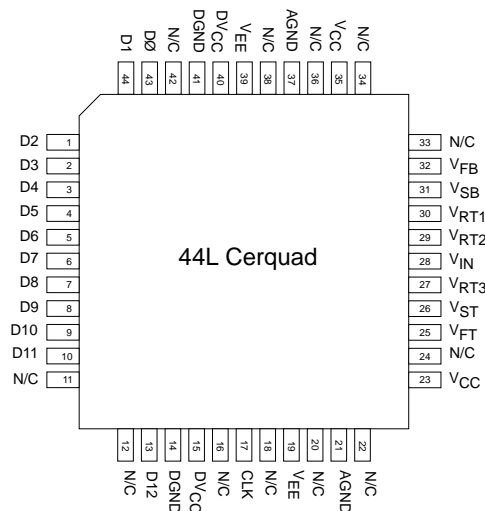
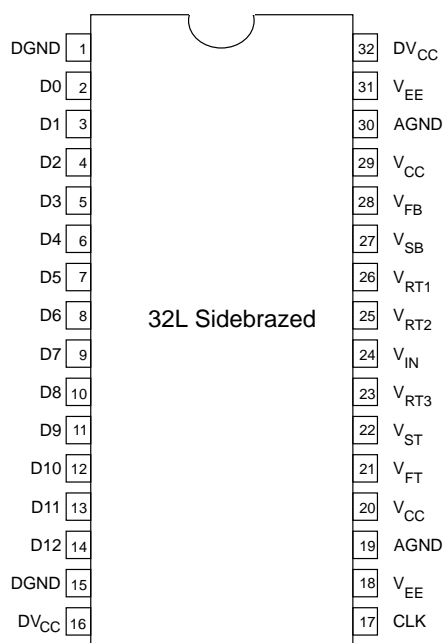

## PIN FUNCTIONS

| Name                               | Function                             |
|------------------------------------|--------------------------------------|
| DGND                               | Digital Ground                       |
| AGND                               | Analog Ground                        |
| D0-D11                             | TTL Outputs (D0=LSB)                 |
| D12                                | TTL Output Overrange                 |
| CLK                                | Clock Input                          |
| V <sub>EE</sub>                    | -5.2 V Supply                        |
| V <sub>CC</sub>                    | +5.0 V supply                        |
| V <sub>RT1</sub> -V <sub>RT3</sub> | Voltage Reference Taps               |
| V <sub>IN</sub>                    | Analog Input                         |
| DV <sub>CC</sub>                   | Digital +5.0 V Supply (TTL Outputs)  |
| V <sub>FT</sub>                    | Force for Top of Reference Ladder    |
| V <sub>ST</sub>                    | Sense for Top of Reference Ladder    |
| V <sub>FB</sub>                    | Force for Bottom of Reference Ladder |
| V <sub>SB</sub>                    | Sense for Bottom of Reference Ladder |

## ORDERING INFORMATION

| PART NUMBER | TEMPERATURE RANGE | PACKAGE            |
|-------------|-------------------|--------------------|
| SPT7921SCJ  | 0 to +70 °C       | 32L Sidebrazed Dip |
| SPT7921SCQ  | 0 to +70 °C       | 44L Cerquad        |

Signal Processing Technologies, Inc. reserves the right to change products and specifications without notice. Permission is hereby expressly granted to copy this literature for informational purposes only. Copying this material for any other use is strictly prohibited.

**WARNING - LIFE SUPPORT APPLICATIONS POLICY** - SPT products should not be used within Life Support Systems without the specific written consent of SPT. A Life Support System is a product or system intended to support or sustain life which, if it fails, can be reasonably expected to result in significant personal injury or death.

Signal Processing Technologies believes that ultrasonic cleaning of its products may damage the wire bonding, leading to device failure. It is therefore not recommended, and exposure of a device to such a process will void the product warranty.