

FEATURES

- Single Video Line Driver Chip
- Internal Bias and Feedback Resistors
- $R_L=150\ \Omega$ (75 Ω Back-Terminated Cable)
- Power-Down Standby Mode
- Tiny 2.9 x 1.6 mm 6-Lead SOT23 Package
- Low Power Dissipation: 41 mW
- 1 V_{P-P} Input Range, 6 dB Voltage Gain
- Flat Response $f_{IN} = 100\ \text{kHz}$ to 10 MHz (typical)
- Single +5 Volt Power Supply

APPLICATIONS

- Digital Video Disk
- Video Line Driver for Encoders
- Digital Video Tape Recorders
- Video Cassette Recorders
- PC Multimedia
- Consumer Video

GENERAL DESCRIPTION

The SPT9406 is a single video line driver chip that takes a standard video chroma signal as an analog input and provides a buffered analog output for driving a 150 Ω load (75 Ω back-terminated cable). The standard video input signal (1 V_{P-P}) is internally biased and amplified 6 dB using internal circuitry and feedback resistors to produce a 2 V_{P-P} into an AC-coupled 150 Ω load. (See the typical interface circuit diagram.)

The SPT9406 features a standby mode which draws only 120 μW of power. Nominal power dissipation (no input) is typically 41 mW. It requires a single +5 V supply, operates over the commercial temperature range (0 to +70 $^{\circ}\text{C}$) and is available in a tiny surface mount (2.9 x 1.6 mm) 6-lead SOT-23 package.

BLOCK DIAGRAM

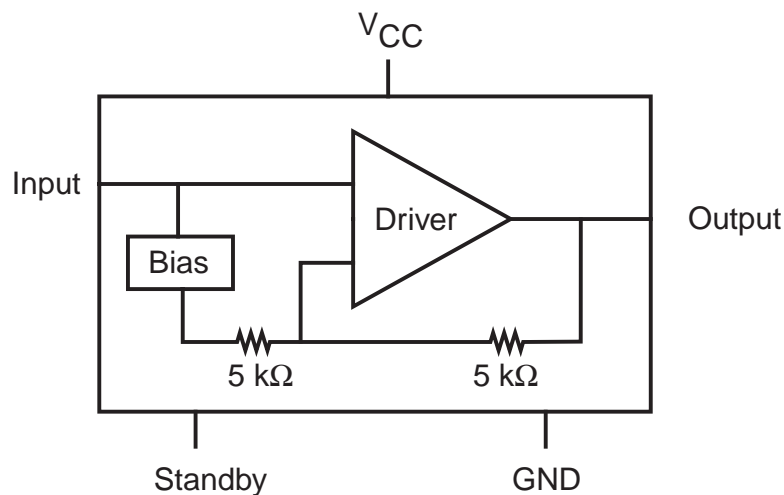

Signal Processing Technologies, Inc.

4755 Forge Road, Colorado Springs, Colorado 80907, USA
Phone: (719) 528-2300 FAX: (719) 528-2370

ABSOLUTE MAXIMUM RATINGS (Beyond which damage may occur)⁽¹⁾ 25 °C

Supply Voltages

V_{CC} +6.0 V

Maximum Power Dissipation

P_D 150 mW

Thermal Impedance (T_A=+25 °C and above)

θ_{CA} 1.2 mW/°C

Temperature

Operating Temperature 0 to +70 °C

Storage Temperature -55 to +150 °C

Note: 1. Operation at any Absolute Maximum Rating is not implied. See Electrical Specifications for proper nominal applied conditions in typical applications.

ELECTRICAL SPECIFICATIONS

T_A = +25 °C, V_{CC} = +5.0 V, V_{IN} = 1.0 V_{P-P} video signal, R_L = 150 Ω, unless otherwise specified.

PARAMETERS	TEST CONDITIONS	TEST LEVEL	SPT9406			UNITS
			MIN	TYP	MAX	
Power Supply						
Supply Current (I _{CC})	No Input	I		8.2	11	mA
V _{CC} Voltage		IV	4.5	5.0	5.5	V
Power Dissipation		I		41	55	mW
Standby Current	Pin 1 Grounded	I		24.0	50	μA
Standby Power Dissipation	Pin 1 Grounded	I		120	200	μW
Digital Input						
Digital Input (Low)	Standby Pin 1	I	0.0	0.1	0.3	V
Digital Input (High)	Standby Pin 1	I	1.8	2.0	V _{CC}	V
Bias Voltage						
Bias Voltage	Pin 4	I	2.15	2.45	2.75	V
Dynamic Performance						
Voltage Gain	f _{IN} = 1 MHz	I	5.2	5.7	6.2	dB
Total Harmonic Distortion	f _{IN} = 1 kHz	I		0.2	1.0	%
Frequency Response	f _{IN} = 1 to 5 MHz	V		-0.5		dB

TEST LEVEL CODES

All electrical characteristics are subject to the following conditions:

All parameters having min/max specifications are guaranteed. The Test Level column indicates the specific device testing actually performed during production and Quality Assurance inspection. Any blank section in the data column indicates that the specification is not tested at the specified condition.

TEST LEVEL

I
II
III
IV
V
VI

TEST PROCEDURE

I 100% production tested at the specified temperature.
 II 100% production tested at T_A = +25 °C, and sample tested at the specified temperatures.
 III QA sample tested only at the specified temperatures.
 IV Parameter is guaranteed (but not tested) by design and characterization data.
 V Parameter is a typical value for information purposes only.
 VI 100% production tested at T_A = +25 °C. Parameter is guaranteed over specified temperature range.

Figure 1 - Typical Interface Circuit

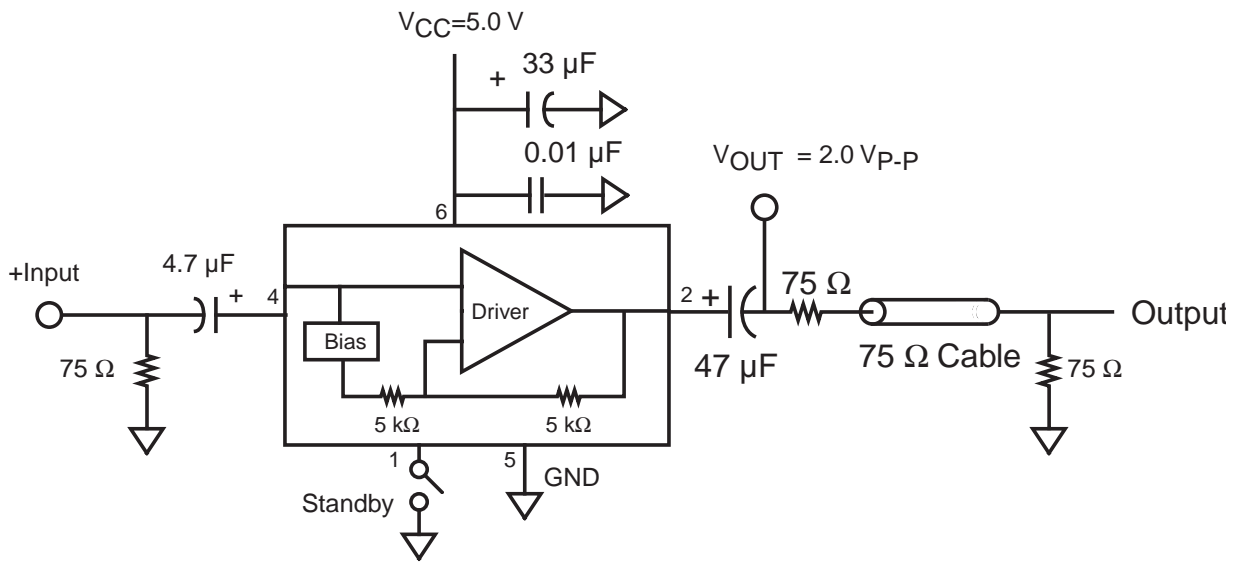

PACKAGE OUTLINE

6-Lead SOT23

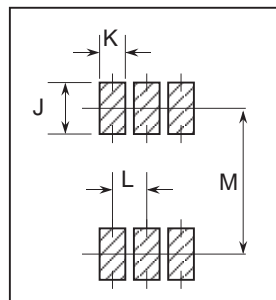
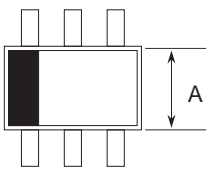

Suggested Pad Layout

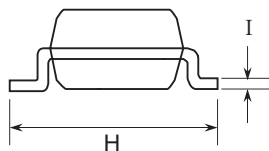
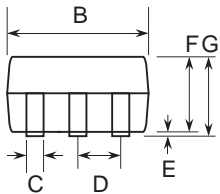

SYMBOL	INCHES		MILLIMETERS	
	MIN	MAX	MIN	MAX
A	0.055	0.071	1.4	1.8
B	0.106	0.122	2.7	3.1
C	0.008	0.016	0.2	0.4
D	0.037 typ		0.95 typ	
E	0.000	0.004	0.0	0.1
F	0.035	0.051	0.9	1.3
G		0.071 max		1.4 max
H	0.098	0.122	2.5	3.1
I	0.001	0.009	0.03	0.23
J	0.039 typ		1.0 typ	
K	0.028 typ		0.7 typ	
L	0.037 typ		0.95 typ	
M	0.094 typ		2.4 typ	

PIN ASSIGNMENTS

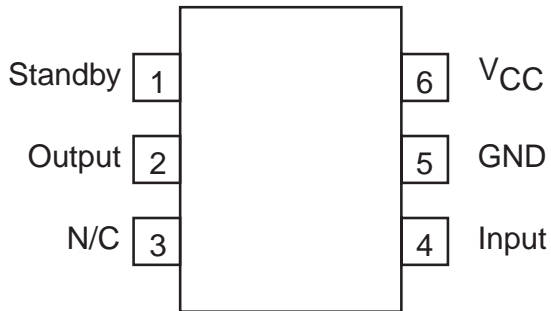

PIN FUNCTIONS

Name	Function
Input	Video Signal Input (typically 1 V _{P-P} , AC coupled)
Output	Buffered Output (typically 2.0 V _{P-P} , R _L = 150 Ω, AC coupled)
Standby	Power Down Standby Mode Select (Low = Standby, Internal Pull-Up)
V _{CC}	+5.0 V Supply
GND	Ground

ORDERING INFORMATION

PART NUMBER	TEMPERATURE RANGE	PACKAGE TYPE
SPT9406SCL	0 to +70 °C	6-Lead SOT23

Signal Processing Technologies, Inc. reserves the right to change products and specifications without notice. Permission is hereby expressly granted to copy this literature for informational purposes only. Copying this material for any other use is strictly prohibited.

WARNING - LIFE SUPPORT APPLICATIONS POLICY - SPT products should not be used within Life Support Systems without the specific written consent of SPT. A Life Support System is a product or system intended to support or sustain life which, if it fails, can be reasonably expected to result in significant personal injury or death.

Signal Processing Technologies believes that ultrasonic cleaning of its products may damage the wire bonding, leading to device failure. It is therefore not recommended, and exposure of a device to such a process will void the product warranty.