



QUAD CURRENT CONTROLLED AMPLIFIER*

DESCRIPTION

The SSM 2024 is a quad class A current controlled amplifier with excellent channel characteristics and low control voltage feedthrough. Signal to noise is better than 82dB at a 0.3% distortion level. The same input signal level yields a control voltage feedthrough ratio of -40dB untrimmed. The four VCAs are completely independent and the controls are ground referenced linear current inputs for easy and direct interfacing. The four current outputs are grouped to facilitate signal summing. For most applications, few external components are required.

FEATURES

- Four Independent VCAs in One Package
- Ground Referenced Linear Current Control Inputs
- 82dB Signal to Noise Referred to 0.3% Distortion
- Low Offset
- -40dB Control Feedthrough (untrimmed)
- Easy Signal Summing
- Low Cost
- Minimum External Components
- Full Class A Operation
- ±15V Supplies
- 5% Gain Matching at Full Output

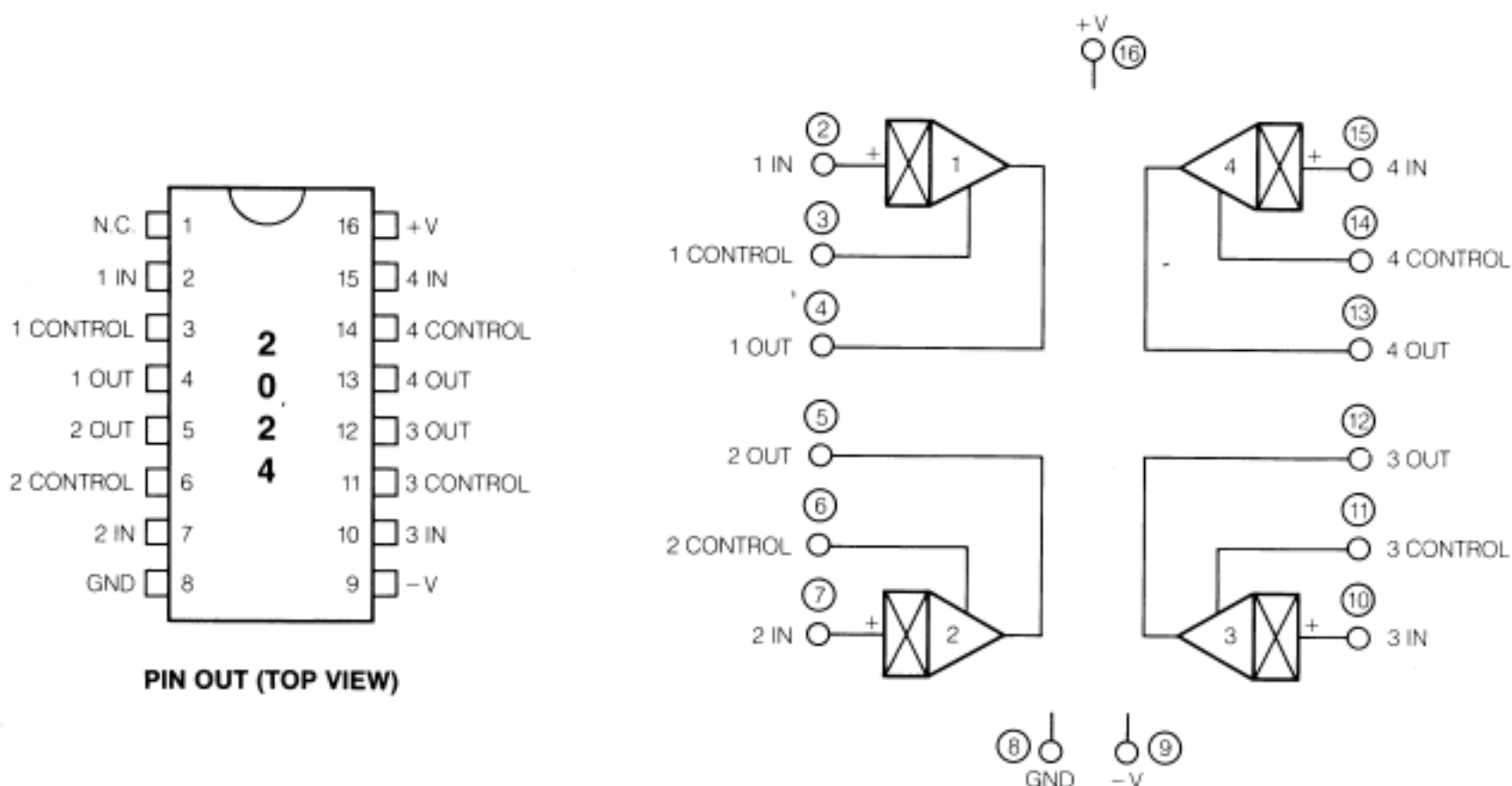

FIGURE 1. BLOCK DIAGRAM

SPECIFICATIONS***OPERATING TEMPERATURE**

- 10°C to + 50°C

STORAGE TEMPERATURE

- 55°C to + 125°C

The following specifications apply for $V_s = \pm 15V$, $T_A = 25^\circ C$, unless otherwise noted.

| PARAMETER (SYMBOL) | MIN | TYP | MAX | UNITS | CONDITIONS |
|---|-------|-----------|-----------|------------|--|
| Positive Supply Current (I_{cc}) | 1.8 | 2.5 | 3.2 | mA | $I_{CON}(1-4) = 0$ $V_s = \pm 15V$ |
| Positive Supply Current (I_{cc}) | 2.5 | 3.5 | 4.5 | mA | $I_{CON}(1-4) = 0$ $V_s = \pm 20V$ |
| Negative Supply Current (I_{ee}) | 0.75 | 1 | 1.3 | mA | $I_{CON}(1-4) = 0$ $V_s = \pm 15V$ |
| Negative Supply Current (I_{ee}) | 1.04 | 1.4 | 1.8 | mA | $I_{CON}(1-4) = 0$ $V_s = \pm 20V$ |
| Gain (G) | 3842 | 4085 | 4330 | $\mu mhos$ | $I_{CON}(1-4) = \pm 500\mu A$ |
| Gain Matching (ΔG) | | | ± 5 | % | $I_{CON}(1-4) = \pm 500\mu A$ |
| Input Offset Voltage (V_{os}) | | $\pm .4$ | ± 1.5 | mV | $V_{IN} = 0V$ $I_{CON}(1-4) = \pm 500\mu A$ |
| Input Offset Voltage (V_{os}) | | $\pm .4$ | ± 1.5 | mV | $I_{CON}(1-4) = + 250\mu A$ |
| Change in Offset Voltage (ΔV_{os}) | | ± 100 | ± 400 | μV | $+ 2.5\mu A \leq I_{CON}(1-4) \leq + 250\mu A$ |
| Change in Offset Voltage (ΔV_{os}) | | $\pm .25$ | ± 1 | mV | $+ 250nA \leq I_{CON}(1-4) \leq + 250\mu A$ |
| Output Leakage (I_{ol}) | | 0.1 | ± 2.5 | nA | $I_{CON}(1-4) = 0$ |
| Control Rejection (untrimmed) | 30 | 41.5 | | dB | $I_{CON}(1-4) = 500\mu A$, $V_{IN}(1-4) = 40mV_{pp}$ |
| Signal to Noise ¹ (S/N) | | 82 | | dB | $V_{IN}(1-4) = 40mV_{pp}$ |
| Distortion ¹ (THD) | | .3 | | % | $V_{IN}(1-4) = 40mV_{pp}$ |
| Threshold Input Control Voltage (V_{TCL}) | + 160 | | + 220 | mV | $I_{OUT}(1-4) = 0$ |

Note 1: Due to automatic testing limitation these specs are guaranteed by bench Q.A. testing. 99% of the units are guaranteed to meet typical specification + 50%.

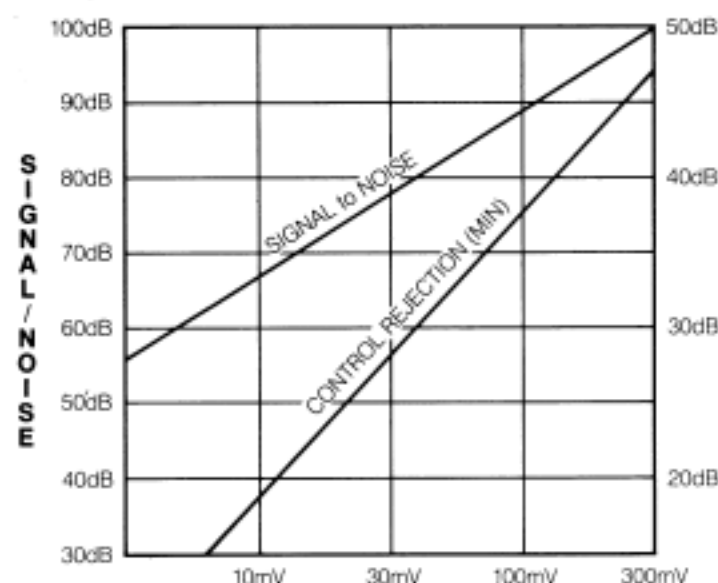

INPUT SIGNAL LEVEL V PEAK TO PEAK

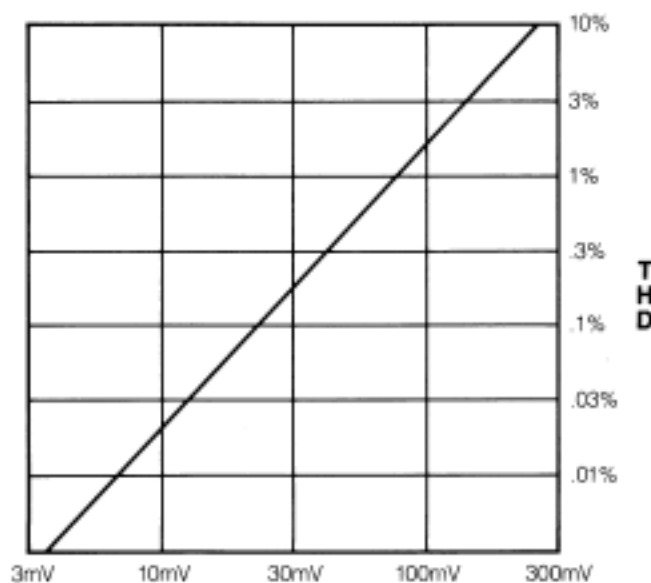

INPUT SIGNAL LEVEL V PEAK TO PEAK

General

The SSM 2024 contains four independent class A non-inverting current controlled transconductance amplifiers. The part will operate from $\pm 9V$ to $\pm 18V$. However, best performance is obtained and the device is tested and guaranteed for all its specifications at $\pm 15V$. A typical application as a four channel mixer is shown below.

2024 Signal Inputs

The impedance from the signal inputs to ground should be about 200Ω for the best offset and control rejection performance. A resistor of this value from the input to ground forms part of an attenuator which scales the input signal to an appropriate level for best overall performance in a given application. When applying any VCA one must consider the following tradeoffs. Increasing the input signal will increase the apparent signal to noise and control rejection ratios at the expense of raising the level of distortion (figures 1 and 2). In many musical instrument applications such as control paths or where a single tone source is being processed, this may not be a serious problem. This is because the distortion only slightly alters the harmonic structure of a signal already rich in harmonics (saw, pulse, triangle). However, in the final VCA where two or more tones are present one must be concerned about Intermodulation Distortion. IM distortion is the extent to which an electronic circuit or medium produces unwanted sidebands at frequencies that are the sums and differences of all harmonics present at the input. The subjective effect of IM distortion is a loss of definition or to muddy the sound. In a class A VCA IM distortion will increase with increasing input level at the same rate as the THD. In applying the 2024 in such cases one would probably want to use an input signal level corresponding to a THD of no more than 0.3%. Design equations for the input attenuator and the gain circuit are given below.

$$V'_{IN} = \frac{200}{R_{IN} + 200} V_{IN}, \quad g_m = 8.17 I_{CONTROL}, \quad I_o = g_m V'_{IN}, \quad I_o = 8.17 I_{CONTROL} \frac{200}{R_{IN} + 200} V_{IN}$$

2024 Outputs

The 2024 is a current output device. The voltage compliance of the outputs is only about $\pm 500mV$ from ground. Where this is not exceeded, such as at the exponential input of a VCF, the output can be connected directly. When a large output signal is desired, an op amp connected as a current to voltage converter must be used. The four outputs are located together at the center of the package so that they can be easily connected in signal summing applications.

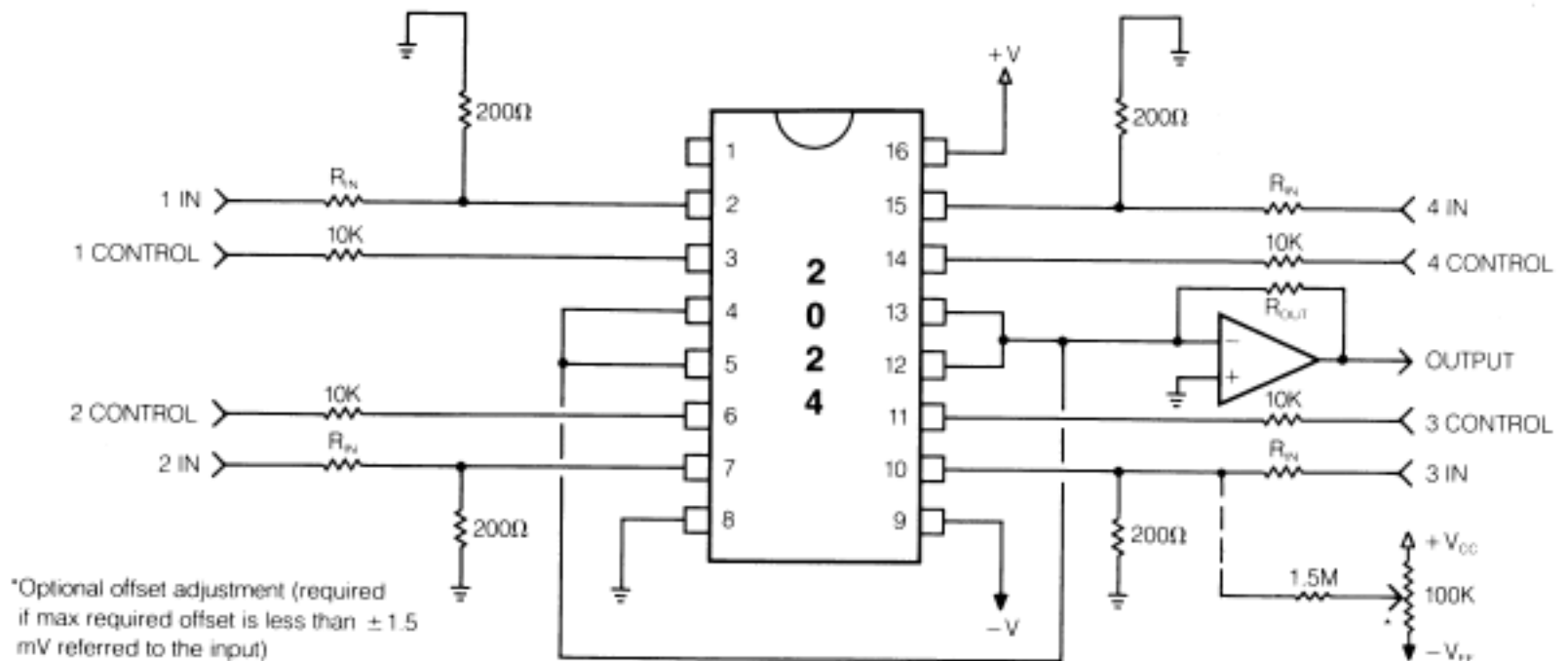

FIGURE 2. 4 CHANNEL MIXER (4-1)

2024 Control Inputs

The control pins of the 2024 are low impedance, ground reference linear current inputs. A resistor can be connected in series from a control pin to a positive control voltage source. The input impedance of the control pin in its active region is about 250Ω . The resistor value should be selected to give a maximum current in the 200 to $500\mu A$ range when the control voltage is at maximum. The VCA will be completely off when the control voltage is less than about $200mV$. The control pin can withstand being shorted either to ground or the negative supply for an indefinite period. A short to the positive supply, however, cannot be maintained for more than 10 to 20 seconds without exceeding the power dissipation rating of the package.

Applications

The 2024 has several obvious areas of application in programmable music systems. The first is as a waveform mixer following the VCOs. Such a mixer, which can be configured in several different ways depending on system philosophy and the number of tone and noise sources available, would allow the various waveforms and tone sources to be mixed under program control. The second is as the final VCA/volume control and filter controller. The amount of keyboard tracking and envelope sweep can thus be programmed. The 2024 can also be used in the modulation section to control the LFO frequency, the amount of LFO, wheel mod, noise and/or modulation ADSR onto modulation bus. A practical LFO controller and a VCA with programmable tremolo amount are shown below in figures 3 and 4. Figure 4 also shows how to directly interface a 2044 VCF output to a 2024 input without an op amp or an offset adjustment.

Figure 5 shows a combined linear/exponential cross fade control circuit using one half of a 2024. This circuit splits a common linear control current between the two VCAs according to the transfer characteristic of a differential pair. A transient generator can be applied to the common linear input to control the overall volume contour while the relative amount of the two signals at the inputs of the VCAs in the mix is determined by the expo control voltage. A single VCA with an exponential control sensitivity can be made by simply grounding the unused pnp collector.

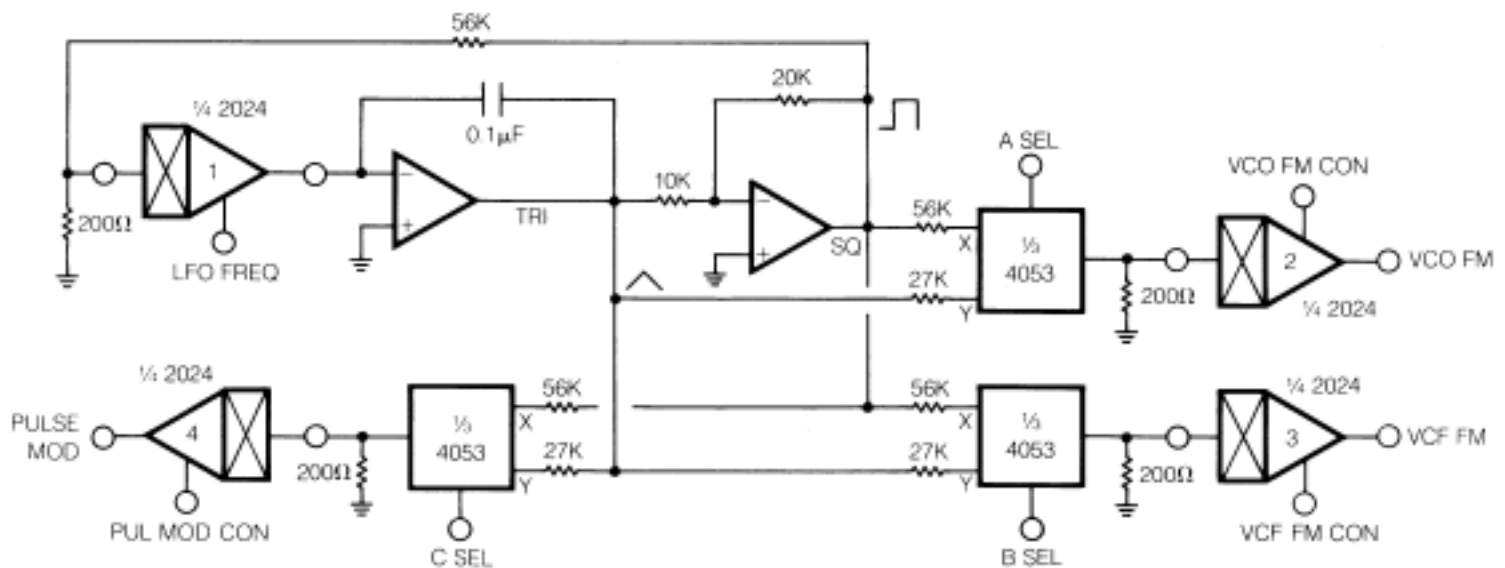

FIGURE 3. LFO CONTROLLER

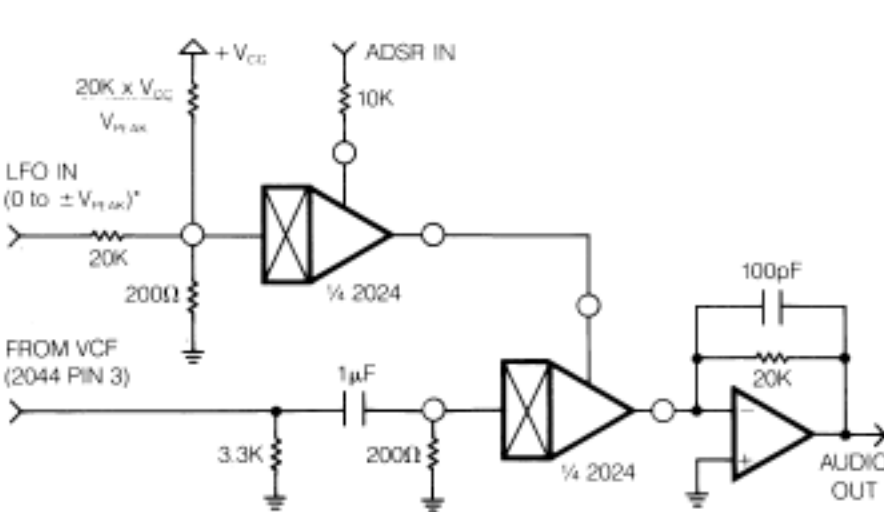

FIGURE 4. VCA WITH TREMOLO

*Modulation increases from zero with no input to 100% at peak level.

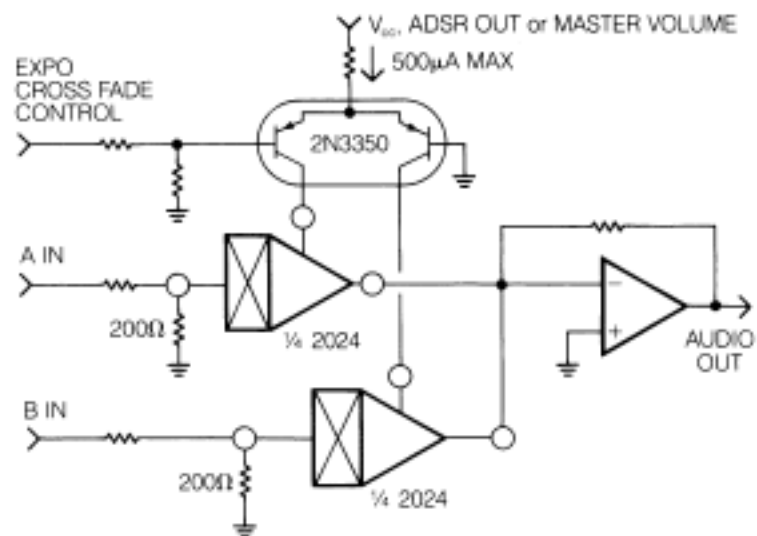

FIGURE 5. LINEAR/EXPONENTIAL CROSS FADE CONTROLLER