



## Product Description

The Stanford Microdevices' SRM-2016 is a high linearity active mixer for use in a wide variety of communication systems covering the 1700-2000 MHz frequency bands. This device operates from a single 5V supply and provides 11dB of conversion gain while requiring only 0dBm input to the integrated LO driver. The SRM-2016 also includes an integrated on chip IF amplifier and is fabricated using silicon germanium device technology.

The SRM-2016 incorporates internal matching on each RF, IF, and LO port to enhance ease of use and to reduce the number of external components required. The RF and LO ports can be driven differential or single ended. Each broadband port has been designed to minimize performance degradation while operating into highly reactive components such as SAW filters.

Functional Block Diagram

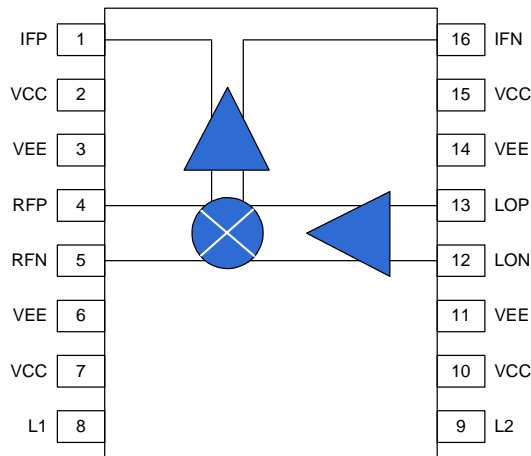

## Key Specifications

Parameters	Test Conditions ( $V_{CC}=5.0V, I=150mA, T=25^{\circ}C$ )	Unit	Min.	Typ.	Max.
RF Frequency Range		MHz	1700		2000
IF Frequency Range		MHz	10	200	300
Input IP3	RF1 = RF2 = -17 dBm/tone	dBm		+17	
Input P1dB		dBm		+4	
Conversion Gain		dB		11	
SSB Noise Figure		dB		14	

The information provided herein is believed to be reliable at press time. Stanford Microdevices assumes no responsibility for inaccuracies or omissions. Stanford Microdevices assumes no responsibility for the use of this information, and all such information shall be entirely at the user's own risk. Prices and specifications are subject to change without notice. No patent rights or licenses to any of the circuits described herein are implied or granted to any third party. Stanford Microdevices does not authorize or warrant any Stanford Microdevices product for use in life-support devices and/or systems.

Copyright 2000 Stanford Microdevices, Inc. All worldwide rights reserved.

522 Almanor Ave., Sunnyvale, CA 94086

Phone: (800) SMI-MMIC

<http://www.stanfordmicro.com>

## SRM-2016

1700 - 2000 MHz High Linearity  
Silicon Germanium  
Active Receive Mixer



16 pin TSSOP with Exposed Pad  
Package Body: 0.20 x 0.17 x 0.04 (inches)  
5.0 x 4.4 x 1.0 (mm)

## Product Features

- Active mixer with conversion gain
- No need for separate external LO driver
- Low LO drive level required to drive mixer
- RF and LO ports may be driven single-ended
- Single supply operation (+5V)
- High LO-RF isolation
- Broadband resistive 50Ω impedances on all three ports

## Applications

- Digital and spread spectrum communication systems
- 1700-2000 MHz transceivers for base station infrastructure equipment



**Absolute Maximum Ratings**

Parameters	Value	Unit
Supply Voltage	+6.0	V <sub>DC</sub>
LO Input	+10	dBm
RF Input	+15	dBm
Operating Temperature	-40 to +85	°C
Storage Temperature	-65 to +150	°C

**Test Conditions**

VCC	+5.0V
TA	+25°C
RF Input	-40 dBm @ 1880 MHz
LO Input	0 dBm @ 1680 MHz

**Product Specifications – AC Performance**

Parameters	Additional Test Conditions	Unit	Min.	Typ.	Max.
RF Frequency Range		MHz	1700		2000
IF Frequency Range		MHz	10	200	300
Input IP3	RF1 = RF2 = -17 dBm/tone	dBm		+17	
Input P1dB		dBm		+4	
Conversion Gain		dB		11	
SSB Noise figure		dB		14	
RF Return Loss		dB		14	
LO Return Loss		dB		14	
IF Return Loss		dB		14	
LO Drive		dBm	-3	0	+3

**Product Specifications – Isolation Performance**

Parameters	Additional Test Conditions	Unit	Min.	Typ.	Max.
Leakage (LO-RF)		dBm		-60	
Leakage (LO-IF)		dBm		-30	

**Product Specifications – Miscellaneous**

Parameters	Additional Test Conditions	Unit	Min.	Typ.	Max.
Supply Voltage		V	+4.75	+5.0	+5.25
Supply Current		mA		150	
Thermal Resistance		°C/W		TBD	

The information provided herein is believed to be reliable at press time. Stanford Microdevices assumes no responsibility for inaccuracies or omissions. Stanford Microdevices assumes no responsibility for the use of this information, and all such information shall be entirely at the user's own risk. Prices and specifications are subject to change without notice. No patent rights or licenses to any of the circuits described herein are implied or granted to any third party. Stanford Microdevices does not authorize or warrant any Stanford Microdevices product for use in life-support devices and/or systems.  
 Copyright 2000 Stanford Microdevices, Inc. All worldwide rights reserved.  
 522 Almanor Ave., Sunnyvale, CA 94086 Phone: (800) SMI-MMIC <http://www.stanfordmicro.com>  
 2 5/01/01 rev 7.0

**Typical Device Performance**

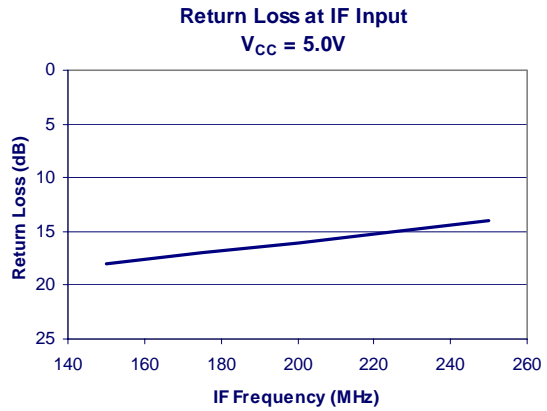
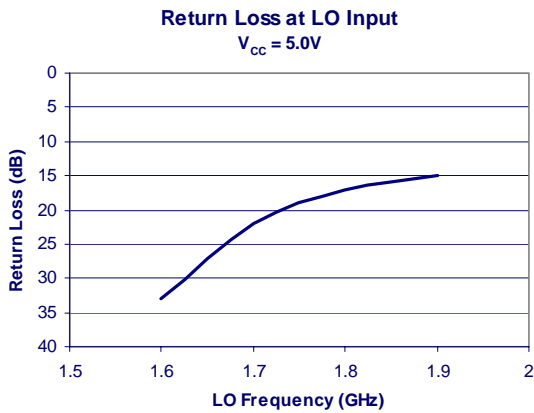
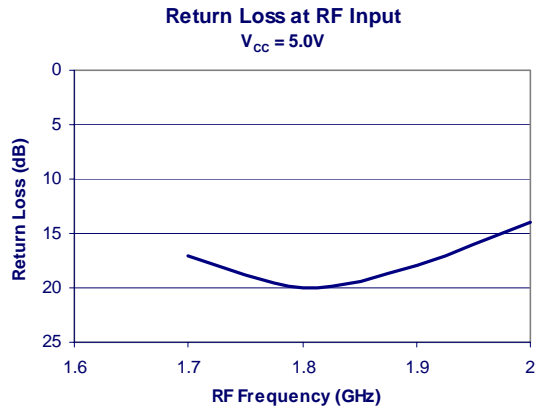
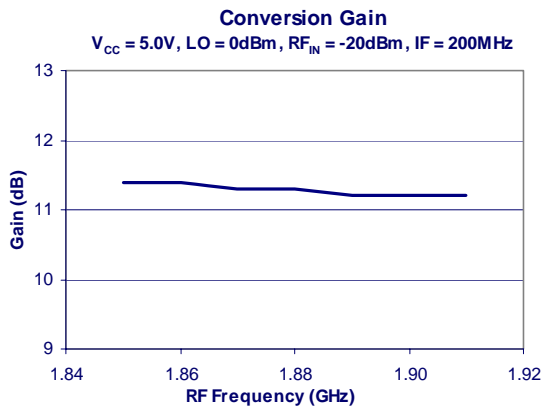



**Advanced Data Sheet**  
**SRM-2016 1700-2000 MHz Receive Mixer**

**Pin Out Description**

Pin #	Function	Description	Additional Comments
1	IFP	IF output, positive terminal	Nominal DC voltage is 1.6V. Output should be AC-coupled
2	VCC	Positive supply (+5V)	
3	VEE	Ground	
4	RFP	RF input, positive terminal	Nominal DC voltage is 2.1V. (Internally biased) Input should be AC-coupled.
5	RFN	RF input, negative terminal	Nominal DC voltage is 2.1V. (Internally biased) Input should be AC-coupled.
6	VEE	Ground	
7	VCC	Positive supply (+5V)	
8	L1	External inductor terminal	Nominal DC voltage is 5V, provided through off chip inductors.
9	L2	External inductor terminal	Nominal DC voltage is 5V, provided through off chip inductors.
10	VCC	Positive supply (+5V)	
11	VEE	Ground	
12	LON	LO input, negative terminal	Nominal DC voltage is 2.4V. (Internally biased) Input should be AC-coupled.
13	LOP	LO input, positive terminal	Nominal DC voltage is 2.4V. (Internally biased) Input should be AC-coupled.
14	VEE	Ground	
15	VCC	Positive supply (+5V)	
16	IFN	IF output, negative terminal	Nominal DC voltage is 1.6V. Output should be AC-coupled.



**Caution: ESD Sensitive**  
 Appropriate precaution in handling, packaging and testing devices must be observed.

**Part Number Ordering Information**

Part Number	Reel Size	Devices/Reel
SRM-2016	TBD	TBD

**Part Symbolization**

The part will be symbolized with a "TBD" marking designator on the top surface of the package.

**Package Dimensions ("16" Package)**

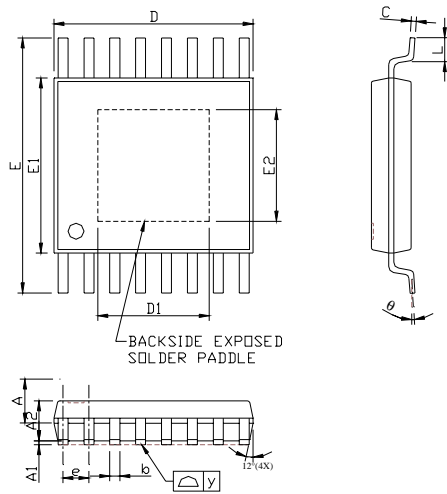

- NOTE
1. PACKAGE BODY SIZES EXCLUDE MOLD FLASH PROTRUSIONS OR GATE BURRS
  2. TOLERANCE  $\pm 0.1$  mm UNLESS OTHERWISE SPECIFIED
  3. COPLANARITY : 0.1 mm
  4. CONTROLLING DIMENSION IS MILLIMETER. CONVERTED INCH DIMENSIONS ARE NOT NECESSARILY EXACT.
  5. FOLLOWED FROM JEDEC MO-153

SYMBOLS	DIMENSIONS IN MILLIMETERS			DIMENSIONS IN INCHES		
	MIN	NOM	MAX	MIN	NOM	MAX
A	—	—	1.15	—	—	0.045
A1	0.00	—	0.10	0.000	—	0.004
A2	0.80	1.00	1.05	0.031	0.039	0.041
b	0.19	—	0.30	0.007	—	0.012
C	0.09	—	0.20	0.004	—	0.008
D	4.90	5.00	5.10	0.193	0.197	0.201
D1	—	2.80	—	—	0.110	—
E	—	6.40	—	—	0.252	—
E1	4.30	4.40	4.50	0.169	0.173	0.177
E2	—	2.80	—	—	0.110	—
e	—	0.65	—	—	0.026	—
L	0.45	0.60	0.75	0.018	0.024	0.030
y	—	—	0.10	—	—	0.004
$\theta$	0°	—	8°	0°	—	8°

**Test PCB Pad Layout**

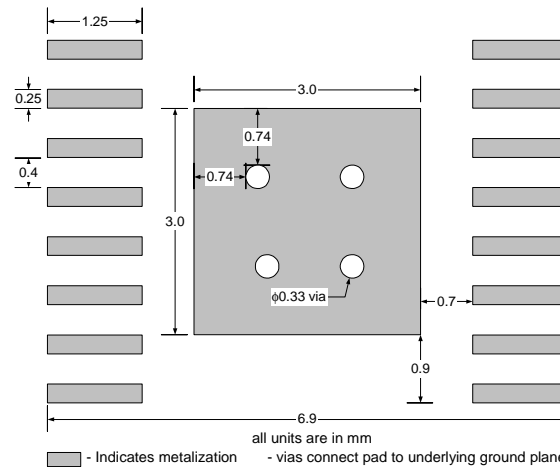

The information provided herein is believed to be reliable at press time. Stanford Microdevices assumes no responsibility for inaccuracies or omissions. Stanford Microdevices assumes no responsibility for the use of this information, and all such information shall be entirely at the user's own risk. Prices and specifications are subject to change without notice. No patent rights or licenses to any of the circuits described herein are implied or granted to any third party. Stanford Microdevices does not authorize or warrant any Stanford Microdevices product for use in life-support devices and/or systems. Copyright 2000 Stanford Microdevices, Inc. All worldwide rights reserved. 522 Almanor Ave., Sunnyvale, CA 94086 Phone: (800) SMI-MMIC 5 <http://www.stanfordmicro.com> 5/01/01 rev 7.0

**Demo Test Board Schematic**

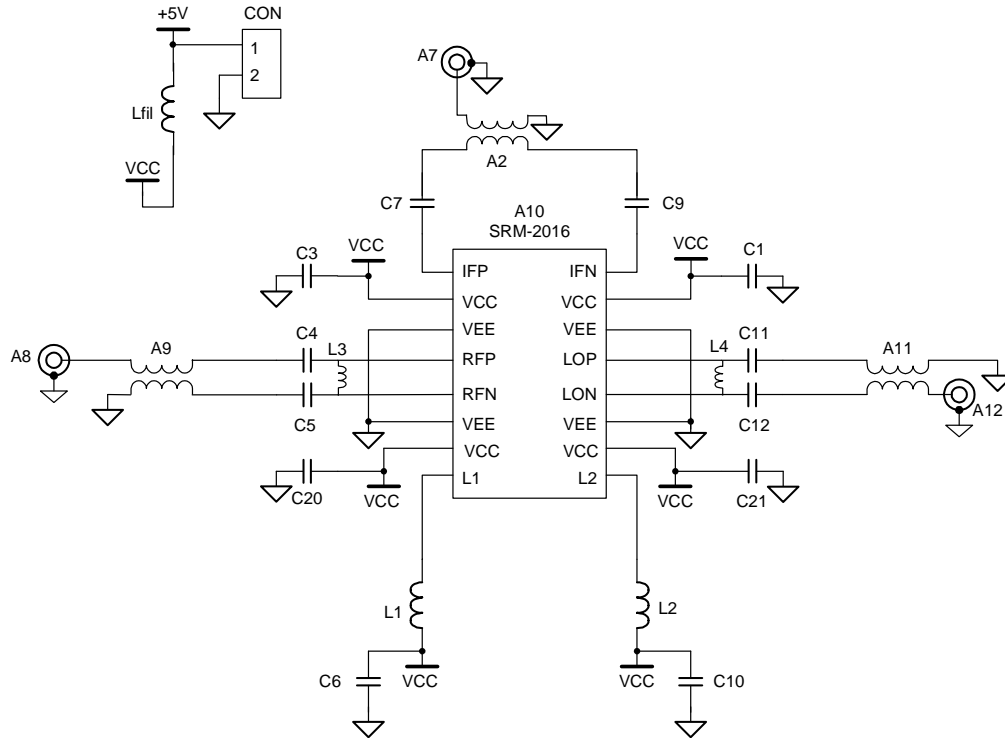

**Bill of Materials**

Component Designator	Value	Qty	Vendor	Part Number	Description
A10		1	SMDI	SRM-2016	SiGe Receive Mixer
A7, A8, A12		3	Johnson Components	142-0701-851	SMA connector, end launch with tab, for 62 mil thick board
CON		1	Digikey	S1212-36-ND	2-pin header
A9, A11	1:1	2	Panasonic	EHF-FD1619	RF transformer
A2	1:1	1	Mini-Circuits	TC1-1	IF transformer
Lfil	1uH	1	Digikey	PCD1008CT-ND	Inductor, 1210 footprint, min. 200mA rating
C1, C3, C20, C21	6.8pF	4	Venkel	C0603COG500-6R8CNE	Capacitor, 0603 footprint
C6, C10	100pF	2	Venkel	C0603COG500-101JNE	Capacitor, 0603 footprint
C7, C9	120pF	2	Venkel	C0603COG500-121JNE	Capacitor, 0603 footprint
C4, C5	2.2pF	2	Venkel	C0603COG500-2R2CNE	Capacitor, 0603 footprint
C11, C12	3.3pF	2	Venkel	C0603COG500-3R3CNE	Capacitor, 0603 footprint
L1, L2	100nH	2	TOKO	LL1608-FSR10J	Inductor, 0603 footprint, high Q series
L3	18nH	1	TOKO	LL1608-FS18NJ	Inductor, 0603 footprint, high Q series
L4	15nH	1	TOKO	LL1608-FS15NJ	Inductor, 0603 footprint, high Q series

The information provided herein is believed to be reliable at press time. Stanford Microdevices assumes no responsibility for inaccuracies or omissions. Stanford Microdevices assumes no responsibility for the use of this information, and all such information shall be entirely at the user's own risk. Prices and specifications are subject to change without notice. No patent rights or licenses to any of the circuits described herein are implied or granted to any third party. Stanford Microdevices does not authorize or warrant any Stanford Microdevices product for use in life-support devices and/or systems.

Copyright 2000 Stanford Microdevices, Inc. All worldwide rights reserved.  
522 Almanor Ave., Sunnyvale, CA 94086

Phone: (800) SMI-MMIC  
6

<http://www.stanfordmicro.com>  
5/01/01 rev 7.0

**Demo Test Board  
(Fully Assembled PCB)**

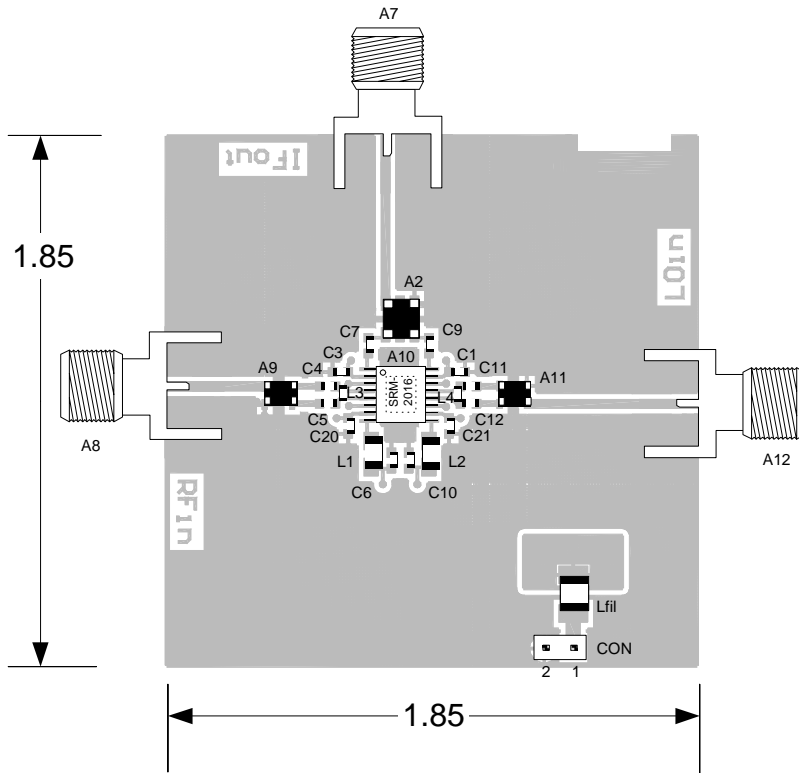

Note: Dimensions in inches