

Product Description

Stanford Microdevices' SGA-2386 is a high performance cascadeable 50-ohm amplifier designed for operation from a 2.7-volt supply. This RFIC uses the latest Silicon Germanium Heterostructure Bipolar Transistor (SiGe HBT) process featuring 1 micron emitters with F_T up to 65 GHz.

This circuit uses a darlington pair topology with resistive feedback for broadband performance as well as stability over its entire temperature range. Internally matched to 50 ohm impedance, the SGA-2386 requires only DC blocking and bypass capacitors for external components.

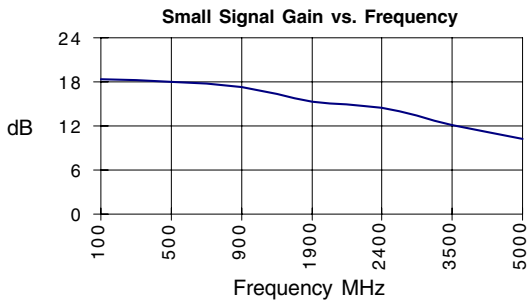

SGA-2386

DC-2800 MHz Silicon Germanium HBT Cascadeable Gain Block



Product Features

- DC-2800 MHz Operation
- 2.7V Single Voltage Supply
- High Output Intercept: +21dBm typ. at 850 MHz
- High Gain: 17.2dB typ. at 850 MHz
- Low Noise Figure: 2.9 dB typ. at 850 MHz

Applications

- Broadband Gain Blocks
- Cordless Phones
- IF/ RF Buffer Amplifier
- Drivers for CATV Amplifiers

Symbol	Parameters: Test Conditions: $Z_0 = 50 \text{ Ohms}$, $I_d = 20 \text{ mA}$, $T = 25^\circ\text{C}$		Units	Min.	Typ.	Max.
P_{1dB}	Output Power at 1dB Compression	$f = 850 \text{ MHz}$ $f = 1950 \text{ MHz}$	dBm dBm		8.8 8.0	
S_{21}	Small Signal Gain	$f = \text{DC} - 1000 \text{ MHz}$ $f = 1000 - 2000 \text{ MHz}$ $f = 2000 - 2800 \text{ MHz}$	dB dB dB	15.5	17.2 15.3 14.0	
S_{12}	Reverse Isolation	$f = \text{DC} - 2800 \text{ MHz}$	dB		21.0	
S_{11}	Input VSWR	$f = \text{DC} - 2800 \text{ MHz}$	-		1.67:1	
S_{22}	Output VSWR	$f = \text{DC} - 2800 \text{ MHz}$	-		1.40:1	
IP_3	Third Order Intercept Point	$f = 850 \text{ MHz}$ $f = 1950 \text{ MHz}$	dBm dBm		21.0 21.2	
NF	Noise Figure	$f = \text{DC} - 1000 \text{ MHz}$ $f = 1000 - 2400 \text{ MHz}$	dB dB		2.9 3.6	
T_D	Group Delay	$f = 1000 \text{ MHz}$	pS		112.0	
V_D	Device Voltage		V	2.4	2.7	3.0

Parameter	Specification			Unit	Test Condition
	Min	Typ.	Max.		
Device Bias					T= 25C
Operating Voltage		2.7		V	
Operating Current		20.0		mA	
500 MHz					T= 25C
Gain		18.0		dB	
Noise Figure		2.9		dB	
Output IP3		20.3		dBm	
Output P1dB		8.2		dBm	
Input Return Loss		19.6		dB	
Isolation		21.1		dB	
850 MHz					T= 25C
Gain		17.2		dB	
Noise Figure		2.9		dB	
Output IP3		21.0		dBm	
Output P1dB		8.8		dBm	
Input Return Loss		12.0		dB	
Isolation		21.4		dB	
1950 MHz					T= 25C
Gain		15.3		dB	
Noise Figure		3.5		dB	
Output IP3		21.2		dBm	
Output P1dB		8.0		dBm	
Input Return Loss		11.5		dB	
Isolation		21.7		dB	
2400 MHz					T= 25C
Gain		14.5		dB	
Noise Figure		3.6		dB	
Output IP3		21.3		dBm	
Output P1dB		7.6		dBm	
Input Return Loss		13.7		dB	
Isolation		21.3		dB	

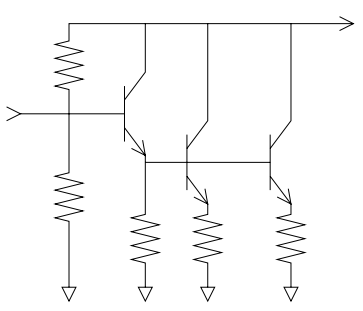
Pin #	Function	Description	Device Schematic
1	RF IN	RF input pin. This pin requires the use of an external DC blocking capacitor chosen for the frequency of operation.	
2	GND	Connection to ground. Use via holes for best performance to reduce lead inductance as close to ground leads as possible.	
3	RF OUT/ BIAS	RF output and bias pin. DC voltage is present on this pin, therefore a DC blocking capacitor is necessary for proper operation.	
4	GND	Sames as Pin 2	

Application Schematic for +5V Operation at 900 MHz

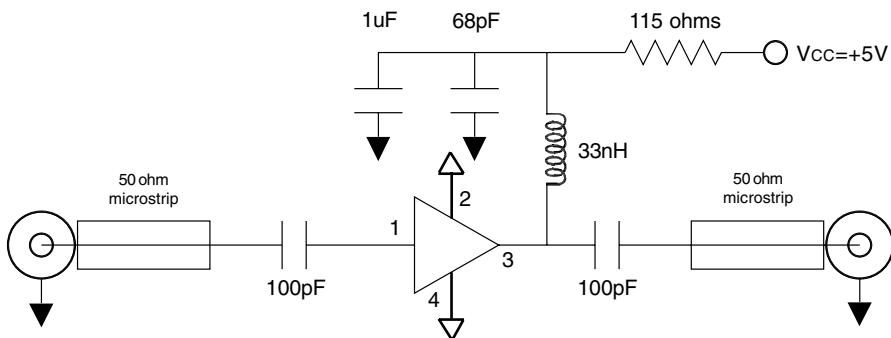

Application Schematic for +5V Operation at 1900 MHz

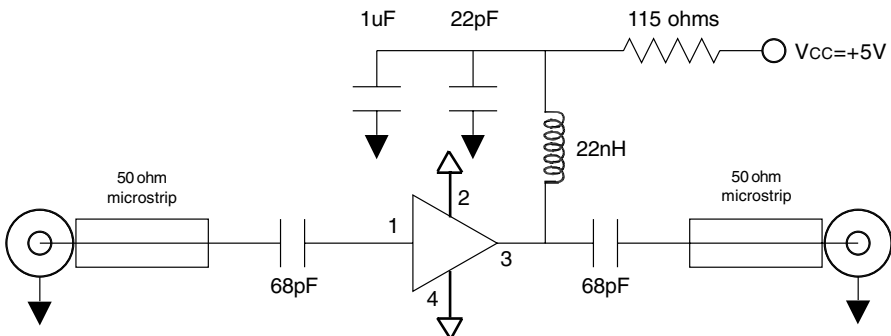

The information provided herein is believed to be reliable at press time. Stanford Microdevices assumes no responsibility for inaccuracies or omissions. Stanford Microdevices assumes no responsibility for the use of this information, and all such information shall be entirely at the user's own risk. Prices and specifications are subject to change without notice. No patent rights or licenses to any of the circuits described herein are implied or granted to any third party. Stanford Microdevices does not authorize or warrant any Stanford Microdevices product for use in life-support devices and/or systems. Copyright 1999 Stanford Microdevices, Inc. All worldwide rights reserved.

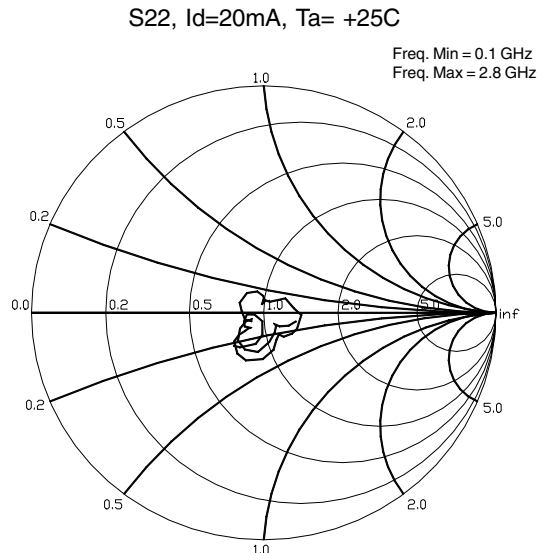
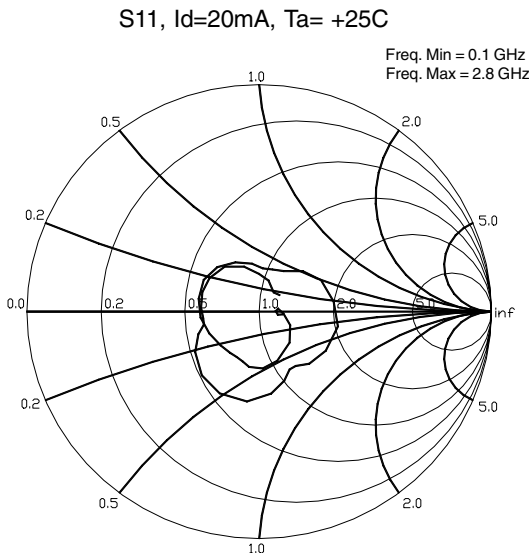
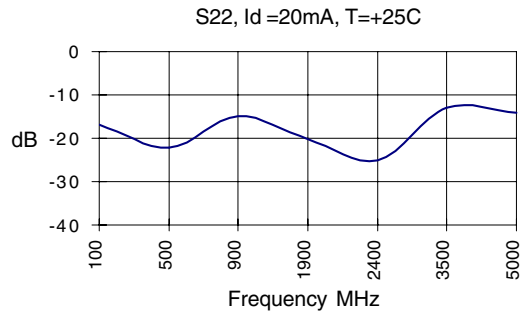
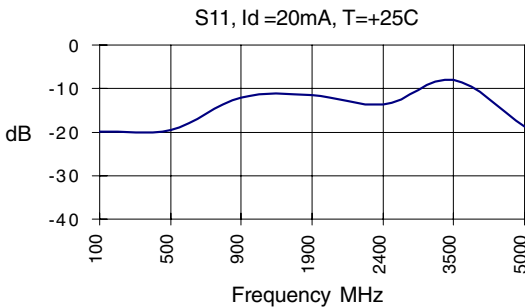
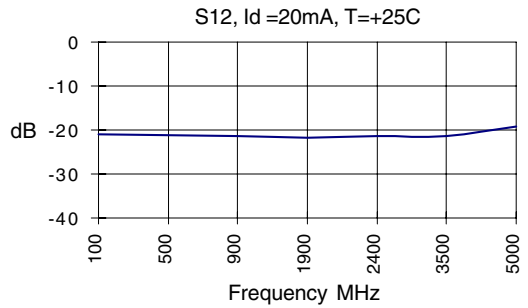
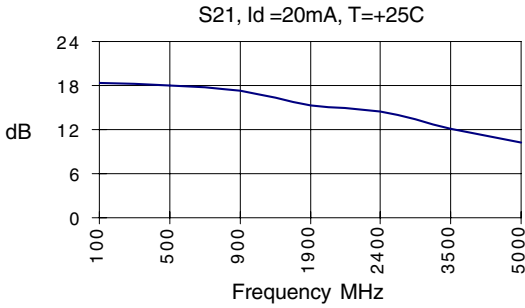

The information provided herein is believed to be reliable at press time. Stanford Microdevices assumes no responsibility for inaccuracies or omissions. Stanford Microdevices assumes no responsibility for the use of this information, and all such information shall be entirely at the user's own risk. Prices and specifications are subject to change without notice. No patent rights or licenses to any of the circuits described herein are implied or granted to any third party. Stanford Microdevices does not authorize or warrant any Stanford Microdevices product for use in life-support devices and/or systems. Copyright 1999 Stanford Microdevices, Inc. All worldwide rights reserved.

S21, Id =20mA, T=-40C

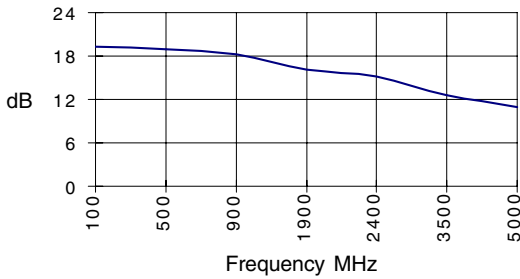

S12, Id =20mA, T=-40C

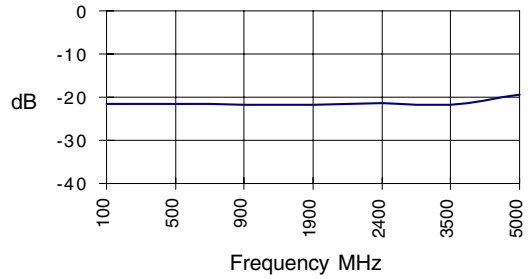

S11, Id =20mA, T=-40C

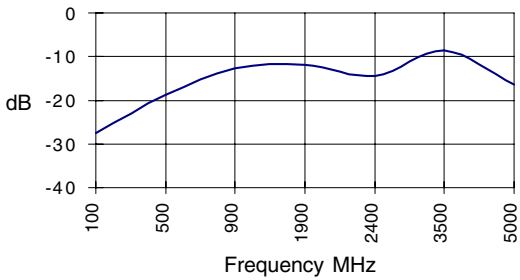

S22, Id =20mA, T=-40C

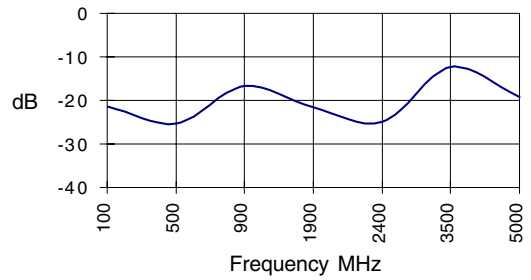

S11, Id=20mA, Ta= -40C

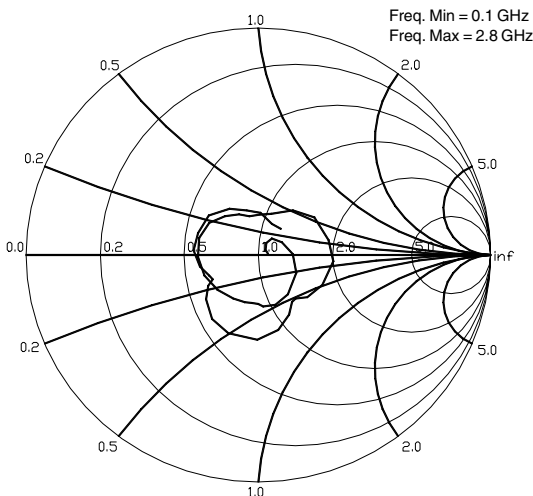

S22, Id=20mA, Ta= -40C

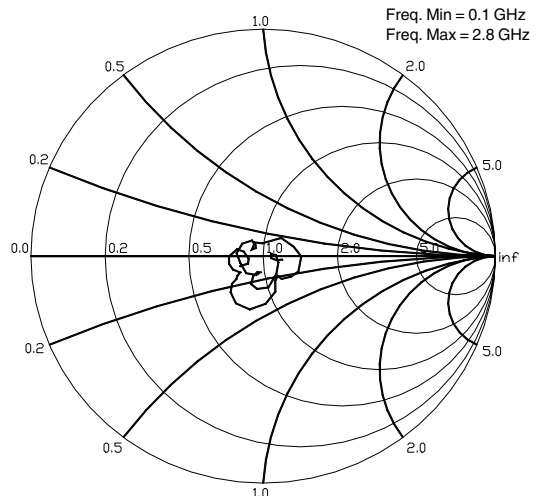

The information provided herein is believed to be reliable at press time. Stanford Microdevices assumes no responsibility for inaccuracies or omissions. Stanford Microdevices assumes no responsibility for the use of this information, and all such information shall be entirely at the user's own risk. Prices and specifications are subject to change without notice. No patent rights or licenses to any of the circuits described herein are implied or granted to any third party. Stanford Microdevices does not authorize or warrant any Stanford Microdevices product for use in life-support devices and/or systems. Copyright 1999 Stanford Microdevices, Inc. All worldwide rights reserved.

S21, Id =20mA, T=85C

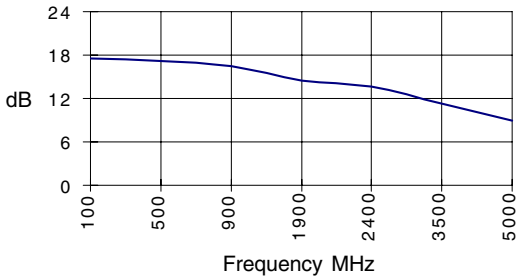

S12, Id =20mA, T=85C

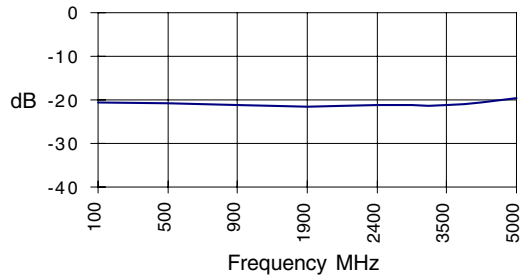

S11, Id =20mA, T=85C

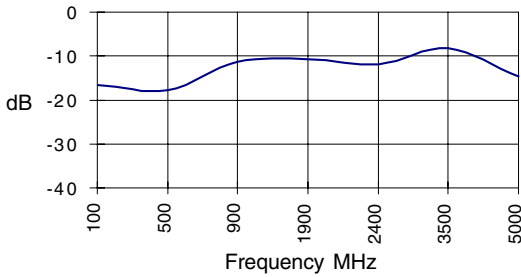

S22, Id =20mA, T=85C

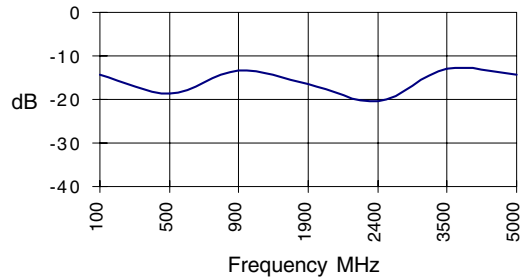

S11, Id=20mA, Ta= 85C

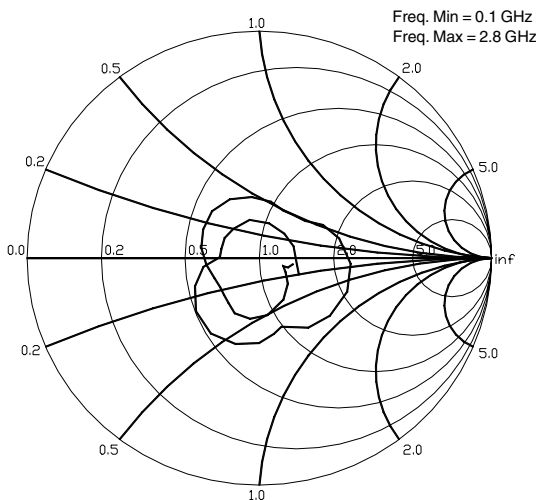

S22, Id=20mA, Ta= 85C

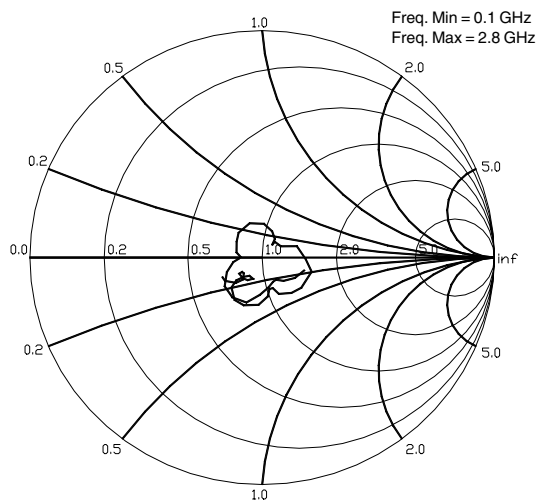

The information provided herein is believed to be reliable at press time. Stanford Microdevices assumes no responsibility for inaccuracies or omissions. Stanford Microdevices assumes no responsibility for the use of this information, and all such information shall be entirely at the user's own risk. Prices and specifications are subject to change without notice. No patent rights or licenses to any of the circuits described herein are implied or granted to any third party. Stanford Microdevices does not authorize or warrant any Stanford Microdevices product for use in life-support devices and/or systems. Copyright 1999 Stanford Microdevices, Inc. All worldwide rights reserved.

Absolute Maximum Ratings

Parameter	Value	Unit
Supply Current	40	mA
Operating Temperature	-40 to +85	C
Maximum Input Power	+7	dBm
Storage Temperature Range	-40 to +85	C
Operating Junction Temperature	+150	C

Caution:



Operation of this device above any one of these parameters may cause permanent damage. Appropriate precautions in handling, packaging and testing devices must be observed.

Thermal Resistance (Lead-Junction):
97° C/W

Part Number Ordering Information

Part Number	Reel Size	Devices/Reel
SGA-2386-TR1	7"	1000
SGA-2386-TR2	13"	3000

Recommended Bias Resistor Values

Supply Voltage(Vs)	3V	5V	7.5V	9V	12V
Rbias (Ohms)	15	115	240	315	465

Package Dimensions

Pin Designation	
1	RF in
2	GND
3	RF out and Bias
4	GND

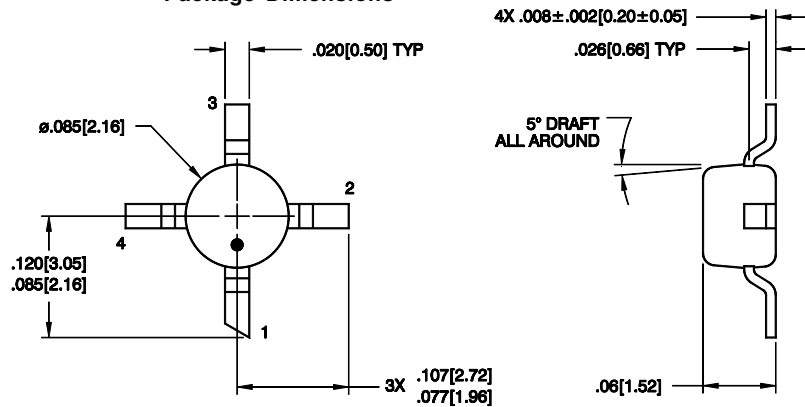

PCB Pad Layout

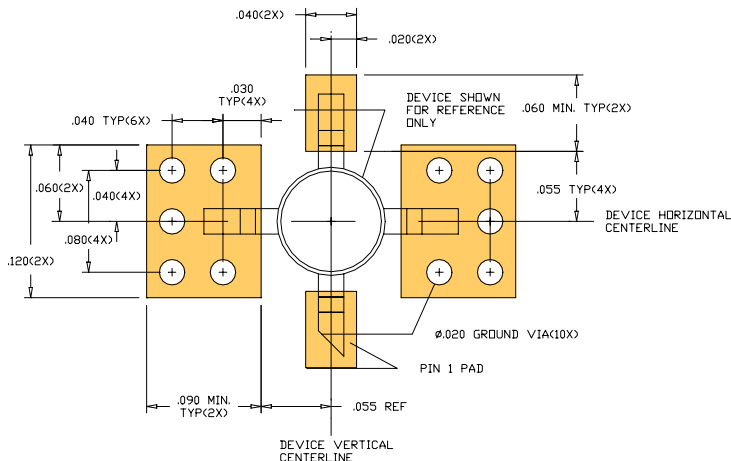

The information provided herein is believed to be reliable at press time. Stanford Microdevices assumes no responsibility for inaccuracies or omissions. Stanford Microdevices assumes no responsibility for the use of this information, and all such information shall be entirely at the user's own risk. Prices and specifications are subject to change without notice. No patent rights or licenses to any of the circuits described herein are implied or granted to any third party. Stanford Microdevices does not authorize or warrant any Stanford Microdevices product for use in life-support devices and/or systems. Copyright 1999 Stanford Microdevices, Inc. All worldwide rights reserved.