

## Product Description

Stanford Microdevices' SNA-686 is a high performance Gallium Arsenide Heterojunction Bipolar Transistor MMIC Amplifier. A Darlington configuration is utilized for broadband performance up to 6 GHz. The heterojunction increases breakdown voltage and minimizes leakage current between junctions. Cancellation of emitter junction non-linearities results in higher suppression of intermodulation products. Typical IP3 at 850 MHz with 65mA is 34 dBm.

These unconditionally stable amplifiers provide 11 dB of gain and 17.7 dBm of 1dB compressed power and require only a single positive voltage supply. Only 2 DC-blocking capacitors, a bias resistor and an optional inductor are needed for operation. This MMIC is an ideal choice for wireless applications such as cellular, PCS, CDPD, wireless data and SONET.

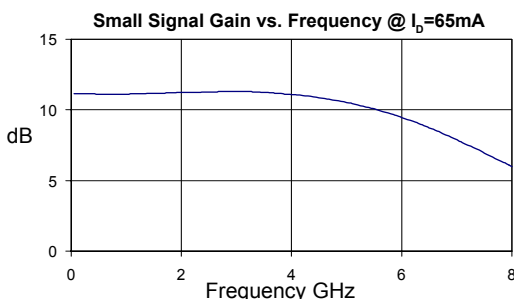

## Electrical Specifications

Symbol	Parameters: Test Conditions: $Z_0 = 50 \text{ Ohms}$ , $I_b = 65mA$ , $T = 25^\circ C$	Units	Min.	Typ.	Max.
$P_{1dB}$	Output Power at 1dB Compression	f = 850 MHz dBm f = 1950 MHz dBm f = 2400 MHz dBm		17.6 17.7 17.4	
$IP_3$	Third Order Intercept Point Power out per tone = 0 dBm	f = 850 MHz dBm f = 1950 MHz dBm f = 2400 MHz dBm		34.0 32.1 30.0	
$S_{21}$	Small Signal Gain	f = 850 MHz dB f = 1950 MHz dB f = 2400 MHz dB	10	11.1 11.2 11.3	
Bandwidth	(Determined by $S_{11}$ , $S_{22}$ Values)			6000	
$S_{11}$	Input VSWR	f = DC-6000 MHz	-	1.3:1	
$S_{22}$	Output VSWR	f = DC-6000 MHz	-	1.4:1	
$S_{12}$	Reverse Isolation	f = 850 MHz dB f = 1950 MHz dB f = 2400 MHz dB		16.3 16.5 16.6	
NF	Noise Figure, $Z_s = 50 \text{ Ohms}$	f = 1950 MHz		7.3	
$V_D$	Device Voltage		4.8	5.3	5.8
Rth,j-l	Thermal Resistance (junction - lead)	$^\circ C/W$		261	

The information provided herein is believed to be reliable at press time. Stanford Microdevices assumes no responsibility for inaccuracies or omissions. Stanford Microdevices assumes no responsibility for the use of this information, and all such information shall be entirely at the user's own risk. Prices and specifications are subject to change without notice. No patent rights or licenses to any of the circuits described herein are implied or granted to any third party. Stanford Microdevices does not authorize or warrant any Stanford Microdevices product for use in life-support devices and/or systems. Copyright 2000 Stanford Microdevices, Inc. All worldwide rights reserved.

## SNA-686

### DC-6 GHz, Cascadable GaAs HBT MMIC Amplifier

#### NGA-686 Recommended for New Designs



## Product Features

- High Output IP3: 34 dBm @ 850 MHz
- Cascadable 50 Ohm Gain Block
- Patented GaAs HBT Technology
- Operates From Single Supply

## Applications

- Cellular, PCS, CDPD, Wireless Data, SONET

### Absolute Maximum Ratings

Operation of this device above any one of these parameters may cause permanent damage.

Bias Conditions should also satisfy the following expression:

$$I_D V_D (\text{max}) < (T_J - T_{OP})/R_{th, j-l}$$

Parameter	Value	Unit
Supply Current	120	mA
Operating Temperature	-40 to +85	C
Maximum Input Power	16	dBm
Storage Temperature Range	-40 to +150	C
Operating Junction Temperature	+175	C

Parameter	Typical		Test Condition ( $I_D = 65 \text{ mA}$ , unless otherwise noted)
	25°C	Unit	
<b>500 MHz</b>			
Gain	11.1	dB	$Z_S = 50 \text{ Ohms}$ Tone spacing = 1 MHz, Pout per tone = 0 dBm
Noise Figure	7.2	dB	
Output IP3	35.0	dBm	
Output P1dB	17.5	dBm	
Input Return Loss	25.2	dB	
Isolation	16.2	dB	
<b>850 MHz</b>			
Gain	11.1	dB	$Z_S = 50 \text{ Ohms}$ Tone spacing = 1 MHz, Pout per tone = 0 dBm
Noise Figure	7.3	dB	
Output IP3	34.0	dBm	
Output P1dB	17.6	dBm	
Input Return Loss	22.3	dB	
Isolation	16.3	dB	
<b>1950 MHz</b>			
Gain	11.2	dB	$Z_S = 50 \text{ Ohms}$ Tone spacing = 1 MHz, Pout per tone = 0 dBm
Noise Figure	7.3	dB	
Output IP3	32.1	dBm	
Output P1dB	17.7	dBm	
Input Return Loss	19.6	dB	
Isolation	16.5	dB	
<b>2400 MHz</b>			
Gain	11.3	dB	Tone spacing = 1 MHz, Pout per tone = 0 dBm
Output IP3	30.0	dBm	
Output P1dB	17.4	dBm	
Input Return Loss	18.4	dB	
Isolation	16.6	dB	

**\*NOTE:** While the SNA-686 can be operated at different bias currents, 65 mA is the recommended bias for lower junction temperature and longer life. This reflects typical operating conditions which we have found to be an optimal balance between high IP3 and MTTF. In general, MTTF is improved to more than 100,000 hours when biasing at 65 mA and operating up to 85°C ambient temperature.

## SNA-686 DC-6GHz Cascadable MMIC Amplifier

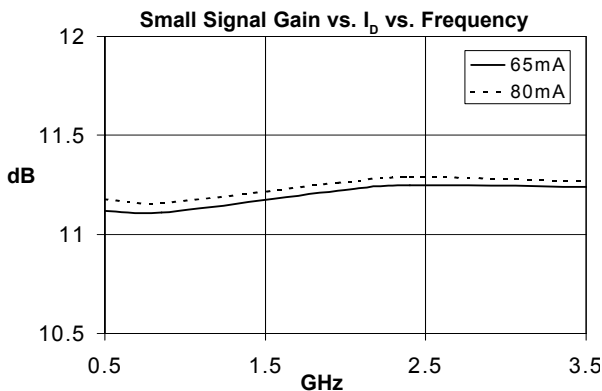
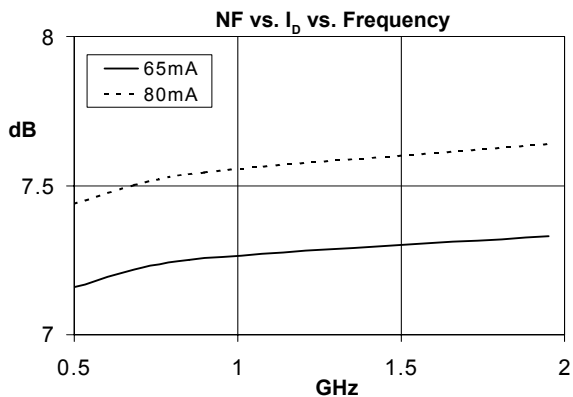
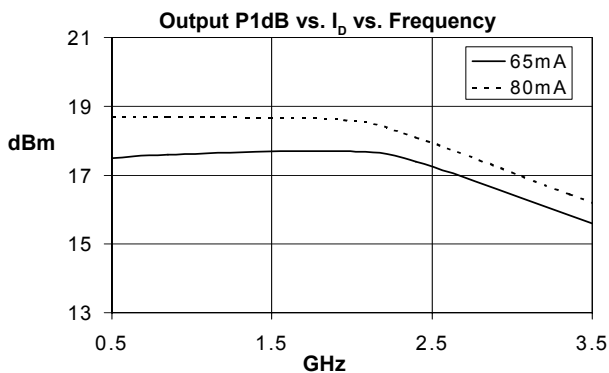
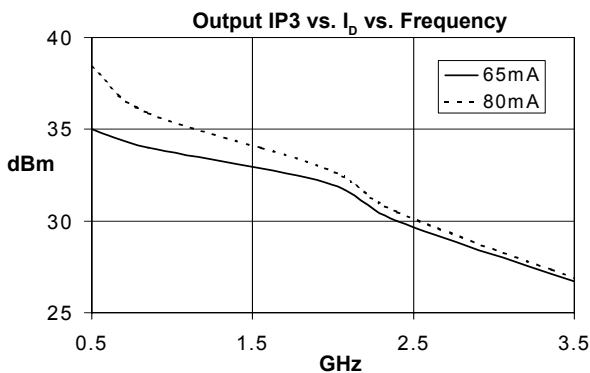
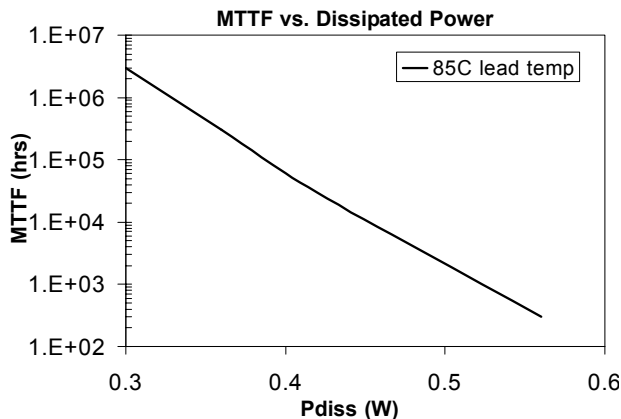
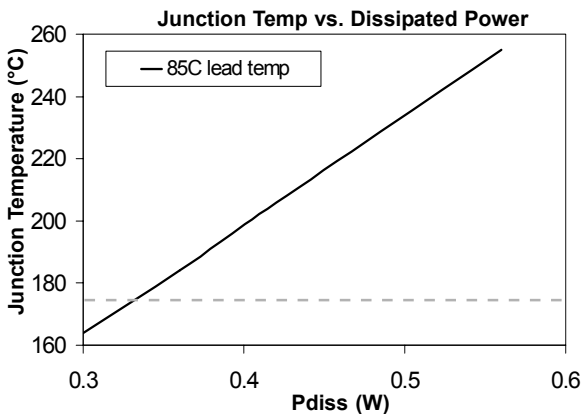

Pin #	Function	Description
1	RF IN	RF input pin. This pin requires the use of an external DC blocking capacitor chosen for the frequency of operation.
2	GND	Connection to ground. Use via holes for best performance to reduce lead inductance. Place vias as close to ground leads as possible.
3	RF OUT/Vcc	RF output and bias pin. Bias should be supplied to this pin through an external series resistor and RF choke inductor. Because DC biasing is present on this pin, a DC blocking capacitor should be used in most applications (see application schematic). The supply side of the bias network should be well bypassed.
4	GND	Same as Pin 2.

**Application Schematic for Operation at 850 MHz**

Recommended Bias Resistor Values				
Supply Voltage(Vs)	8V	9V	12V	15V
Rbias (Ohms) @ 65 mA	43	56	100	150
Rbias (Ohms) @ 80 mA	30	43	82	120

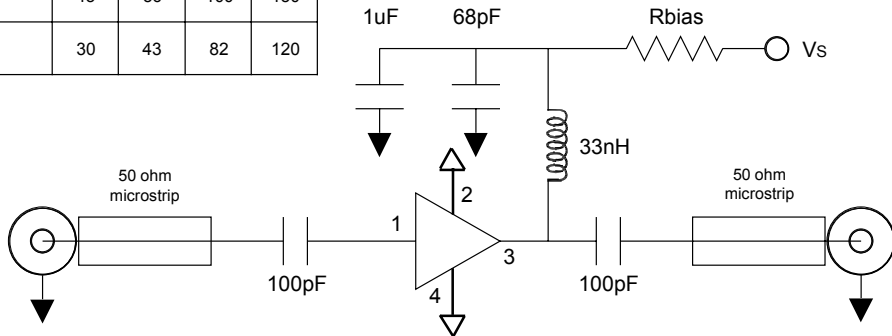

**Application Schematic for Operation at 1950 MHz**

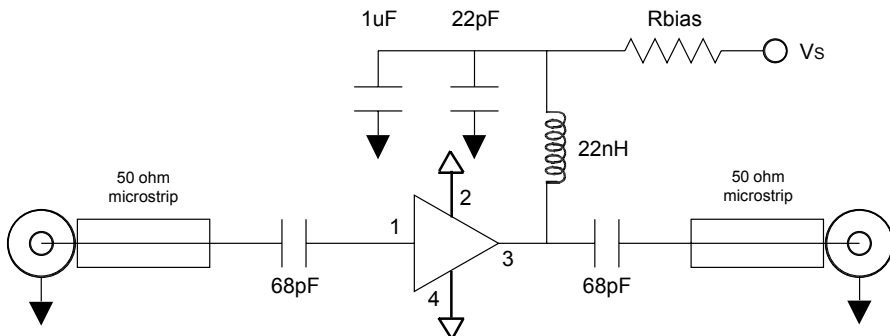

## SNA-686 DC-6GHz Cascadable MMIC Amplifier

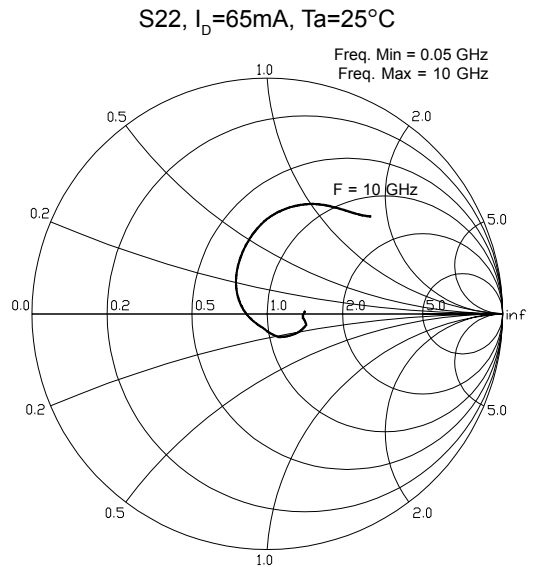
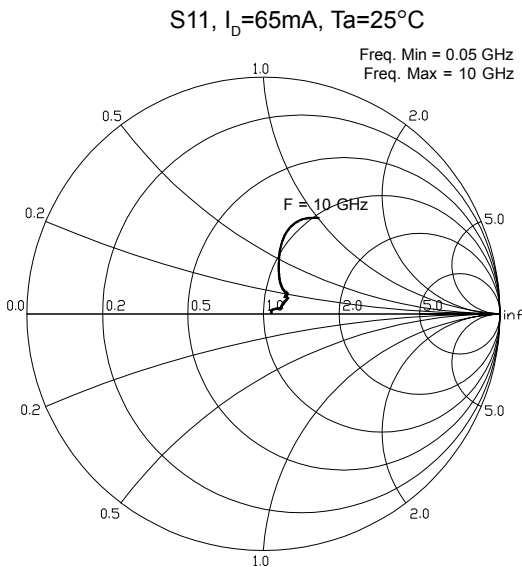
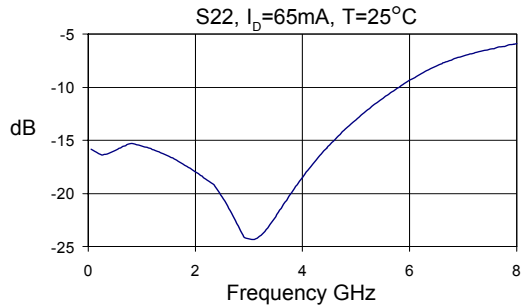
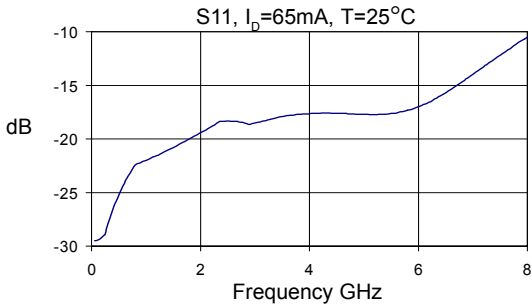
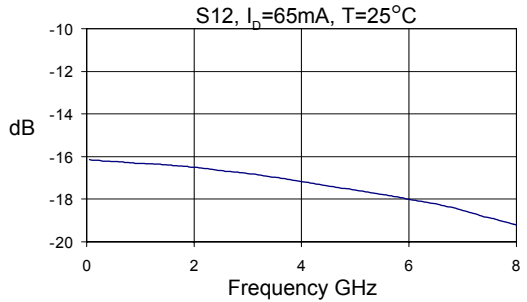
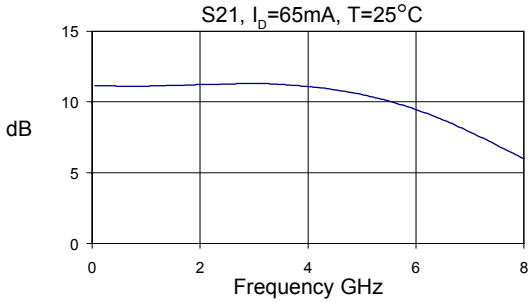

## SNA-686 DC-6GHz Cascadable MMIC Amplifier

### Part Number Ordering Information

Part Number	Reel Size	Devices/Reel
SNA-686	7"	1000



### Caution ESD Sensitive:

Appropriate precautions in handling, packaging and testing devices must be observed.

### Part Symbolization

The part will be symbolized with an "S6" designator on the top surface of the package.

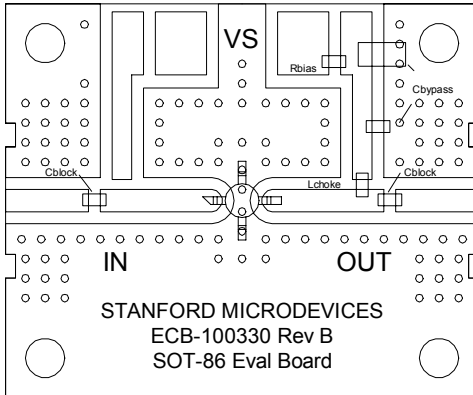

Evaluation Board Layout

### PCB Pad Layout

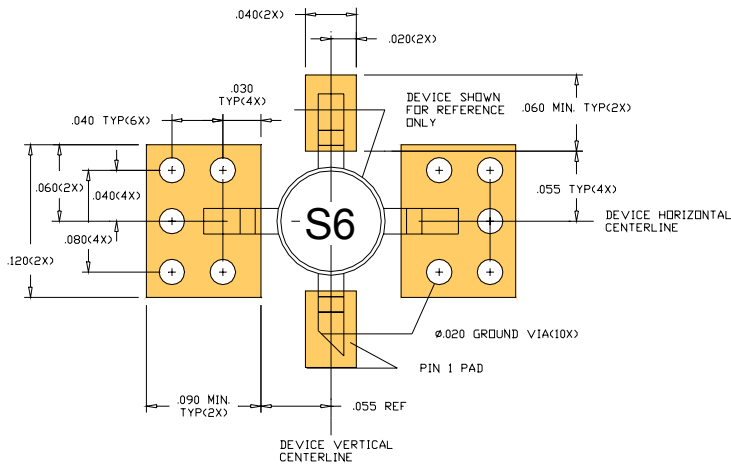

### Package Dimensions

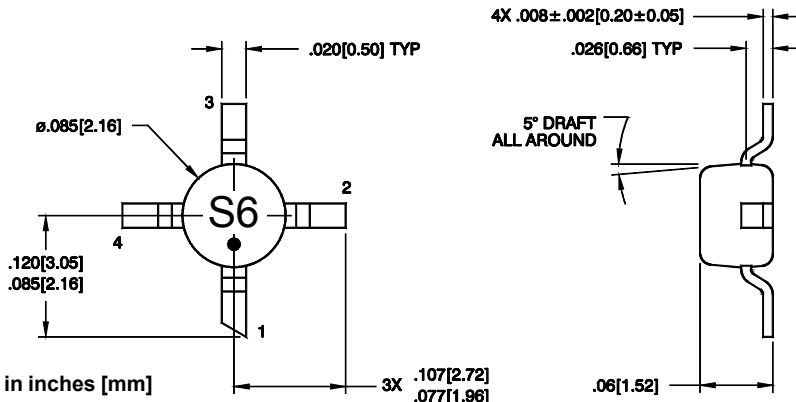

Dimensions are in inches [mm]