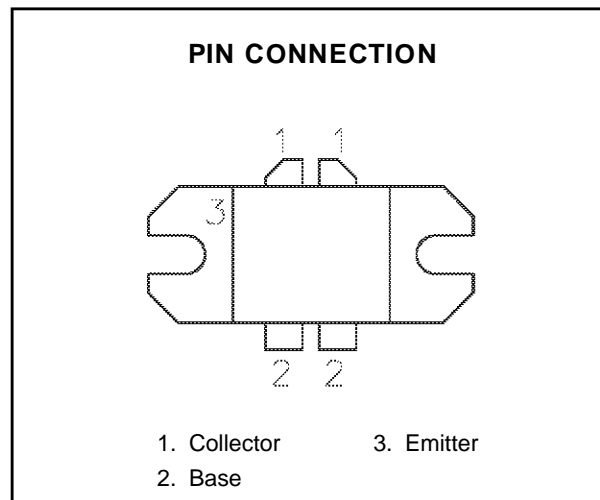
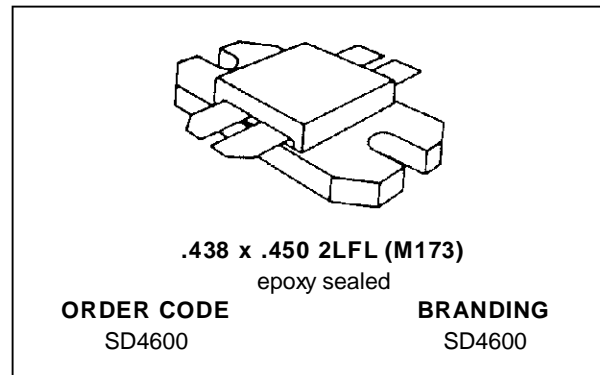

## RF & MICROWAVE TRANSISTORS CELLULAR BASE STATION APPLICATIONS

PRELIMINARY DATA

- GOLD METALLIZATION
- 860-960 MHz
- 26 VOLTS
- EFFICIENCY 50% MIN.
- P<sub>OUT</sub> = 60 W MIN. WITH 7.5 dB GAIN

**DESCRIPTION**

The SD4600 is designed for 960MHz mobile base stations in both analog and digital applications. Including double input and output matching networks, the SD4600 features high impedances allowing operation over the full 860 to 960 MHz bandwidth.

**ABSOLUTE MAXIMUM RATINGS** (T<sub>case</sub> = 25°C)

Symbol	Parameter	Value	Unit
V <sub>CBO</sub>	Collector-Base Voltage	60	V
V <sub>CEO</sub>	Collector-Emitter Voltage	28	V
V <sub>EBO</sub>	Emitter-Base Voltage	3.5	V
I <sub>C</sub>	Device Current	8	A
P <sub>DISS</sub>	Power Dissipation	146	W
T <sub>J</sub>	Junction Temperature	+200	°C
T <sub>STG</sub>	Storage Temperature	- 65 to +150	°C

**THERMAL DATA**

R <sub>TH(j-c)</sub>	Junction-Case Thermal Resistance	1.2	°C/W
----------------------	----------------------------------	-----	------

\*Applies only to rated RF amplifier operation

## SD4600

### ELECTRICAL SPECIFICATIONS ( $T_{case} = 25^{\circ}C$ )

STATIC (Total Device)

Symbol	Test Conditions	Value			Unit
		Min.	Typ.	Max.	
$BV_{CBO}$	$I_C = 100mA$	60	—	—	V
$BV_{EBO}$	$I_E = 20mA$	3.5	—	—	V
$BV_{CEO}$	$I_C = 100mA$	28	—	—	V
$I_{CEO}$	$V_{CE} = 25V$	—	—	30	mA
$h_{FE}$	$V_{CE} = 5V$ $I_C = 3A$	25	—	80	—

DYNAMIC (Total Device)

Symbol	Test Conditions	Value			Unit
		Min.	Typ.	Max.	
$P_{OUT}$	$f = 960MHz$ $V_{CC} = 26V$ $I_{CQ} = .200A$	60	65	—	W
$\eta_c$	$f = 960MHz$ $V_{CC} = 26V$ $I_{CQ} = .200A$	50	58	—	%
$G_P$	$f = 960MHz$ $V_{CC} = 26V$ $I_{CQ} = .200A$	7.5	8.0	—	dB
VSWR	$f = 960MHz$ $V_{CC} = 26V$	5:1	—	—	—

### TYPICAL PERFORMANCE

#### POWER OUTPUT & COLLECTOR EFFICIENCY vs POWER INPUT

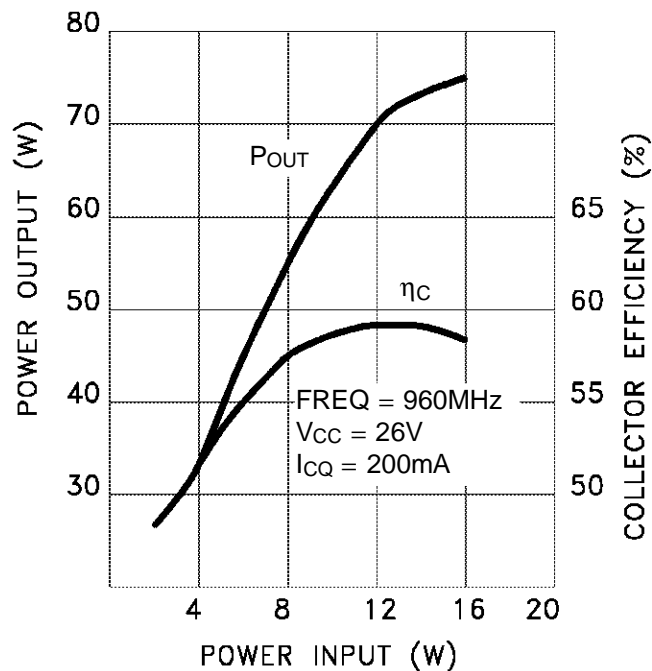

## IMPEDANCE DATA

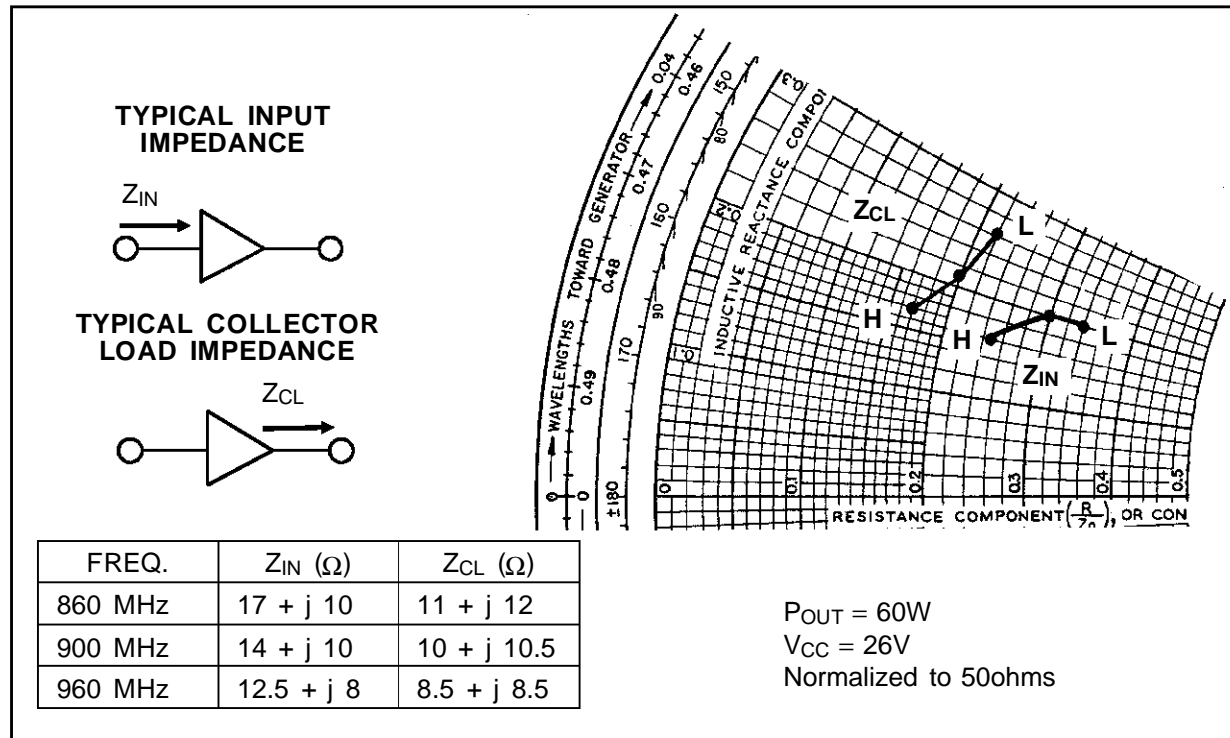

## TEST CIRCUIT

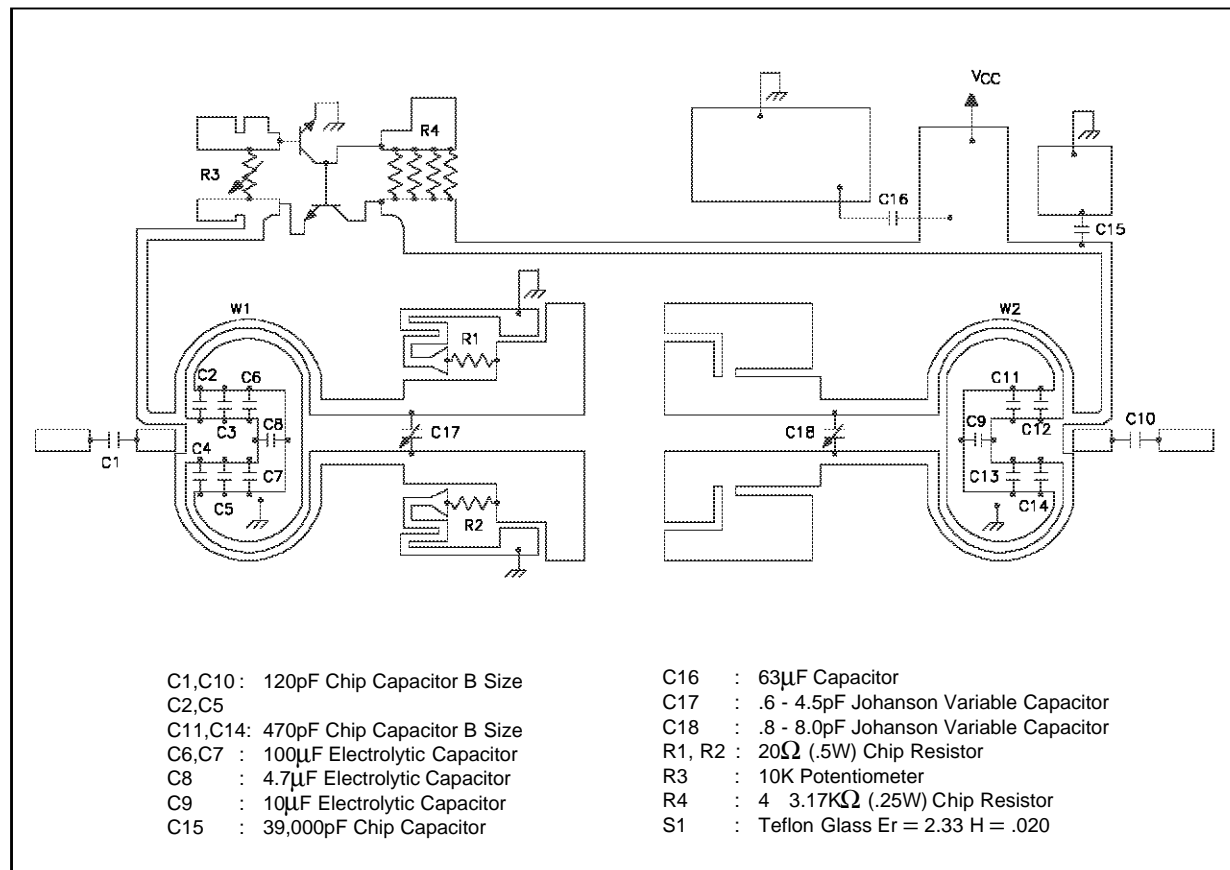

PACKAGE MECHANICAL DATA

Ref. Dwg. No.: 12-0173

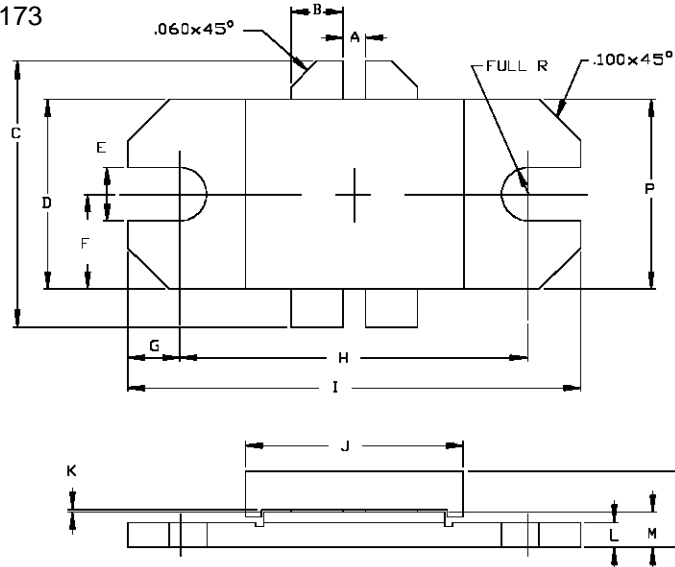

SGS-THOMSON MICROELECTRONICS			CONT'D		
	MINIMUM Inches/mm	MAXIMUM Inches/mm		MINIMUM Inches/mm	MAXIMUM Inches/mm
A	.055/1,40		K	.002/0,05	.006/0,15
B	.120/3,05	.130/3,30	L	.055/1,40	.065/1,65
C		.785/19,94	M	.080/2,03	.095/2,41
D	.455/11,56	.465/11,81	N		.195/4,95
E	.125/3,18		P	.455/11,56	.465/11,81
F	.230/5,84				
G	.128/3,25				
H	.838/21,28	.850/21,59			
I	1.095/27,81	1.105/28,07			
J	.525/13,34	.535/13,59			

Information furnished is believed to be accurate and reliable. However, SGS-THOMSON Microelectronics assumes no responsibility for the consequences of use of such information nor for any infringement of patents or other rights of third parties which may results from its use. No license is granted by implication or otherwise under any patent or patent rights of SGS-THOMSON Microelectronics. Specifications mentioned in this publication are subject to change without notice. This publication supersedes and replaces all information previously supplied. SGS-THOMSON Microelectronics products are not authorized for use as critical components in life support devices or systems without express written approval of SGS-THOMSON Microelectronics.

© 1994 SGS-THOMSON Microelectronics - All Rights Reserved

SGS-THOMSON Microelectronics GROUP OF COMPANIES  
 Australia - Brazil - France - Germany - Hong Kong - Italy - Japan - Korea - Malaysia - Malta - Morocco - The Netherlands -  
 Singapore - Spain - Sweden - Switzerland - Taiwan - Thailand - United Kingdom - U.S.A