



# M40Z300 M40Z300W

## NVRAM CONTROLLER for up to EIGHT LPSRAM

- CONVERT LOW POWER SRAMs into NVRAMs
- PRECISION POWER MONITORING and POWER SWITCHING CIRCUITRY
- AUTOMATIC WRITE-PROTECTION when  $V_{CC}$  is OUT-OF-TOLERANCE
- TWO INPUT DECODER ALLOWS CONTROL for up to 8 SRAMs (with 2 devices active in parallel)
- CHOICE of SUPPLY VOLTAGES and POWER-FAIL DESELECT VOLTAGES:
  - M40Z300:
    - $V_{CC} = 4.5V$  to  $5.5V$
    - $THS = V_{SS} 4.5V \leq V_{PFD} \leq 4.75V$
    - $THS = V_{OUT} 4.2V \leq V_{PFD} \leq 4.5V$
  - M40Z300W:
    - $V_{CC} = 3.0V$  to  $3.6V$
    - $THS = V_{SS} 2.8V \leq V_{PFD} \leq 3.0V$
    - $V_{CC} = 2.7V$  to  $3.3V$
    - $THS = V_{OUT} 2.5 \leq V_{PFD} \leq 2.7V$
- RESET OUTPUT ( $\overline{RST}$ ) for POWER ON RESET
- LESS THAN 12ns CHIP ENABLE ACCESS PROPAGATION DELAY (for 5.0V device)
- PACKAGING INCLUDES a 28-LEAD SOIC and SNAPHAT® TOP, or a 16-LEAD SOIC (to be Ordered Separately)
- SOIC PACKAGE PROVIDES DIRECT CONNECTION for a SNAPHAT TOP which CONTAINS the BATTERY
- BATTERY LOW PIN ( $\overline{BL}$ )

### DESCRIPTION

The M40Z300/W NVRAM Controller is a self-contained device which converts a standard low-power SRAM into a non-volatile memory. A precision voltage reference and comparator monitors the  $V_{CC}$  input for an out-of-tolerance condition.

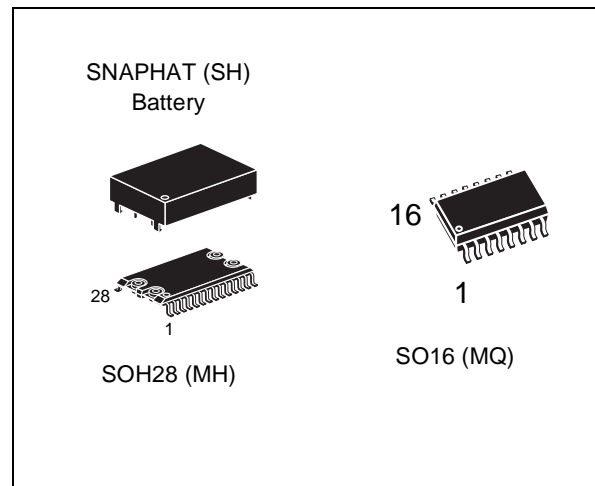

Figure 1. Logic Diagram

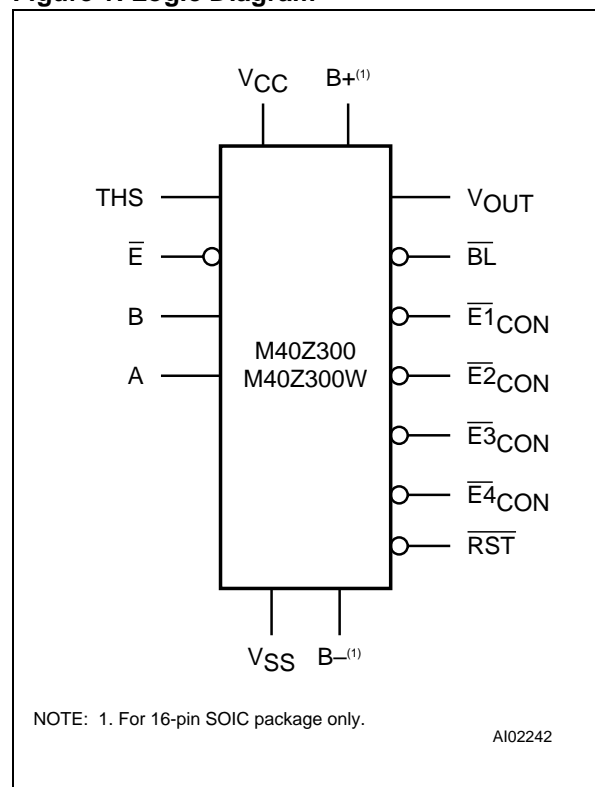

Figure 2A. SOIC28 Connections

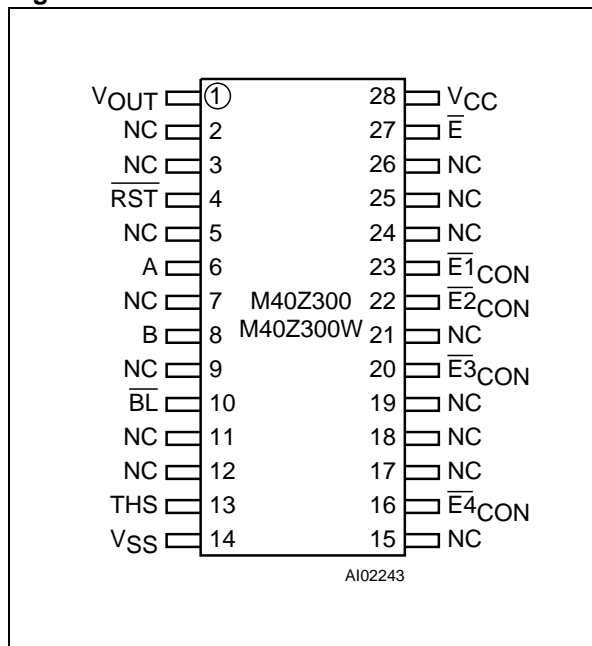

Figure 2B. SOIC16 Connections

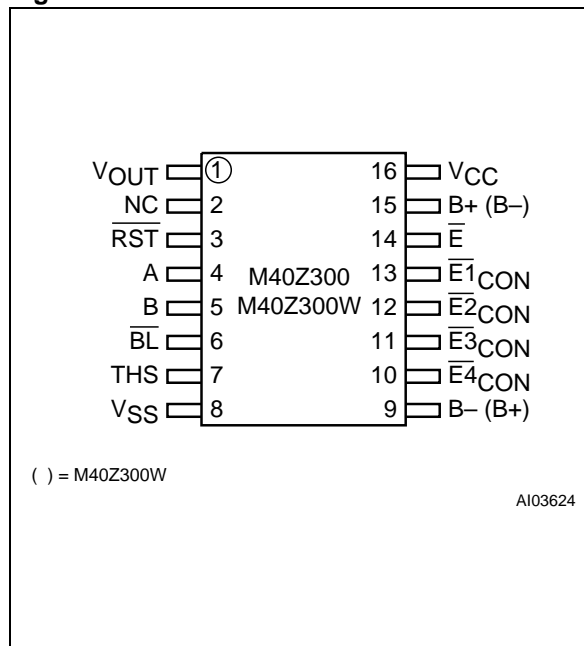

Table 1. Signal Names

THS	Threshold Select Input
$\overline{E}$	Chip Enable Input
$\overline{E1CON}$ - $\overline{E4CON}$	Conditioned Chip Enable Output
A, B	Decoder Inputs
$\overline{RST}$	Reset Output (Open Drain)
$\overline{BL}$	Battery Low Output (Open Drain)
VOUT	Supply Voltage Output
VCC	Supply Voltage
VSS	Ground
B+	Positive Battery Pin
B-	Negative Battery Pin
NC	Not Connected Internally

When an invalid  $V_{CC}$  condition occurs, the conditioned chip enable outputs ( $\overline{E1CON}$  to  $\overline{E4CON}$ ) are forced inactive to write-protect the stored data in the SRAM. During a power failure, the SRAM is switched from the  $V_{CC}$  pin to the lithium cell within the SNAPHAT to provide the energy required for data retention. On a subsequent power-up, the SRAM remains write protected until a valid power condition returns.

The 28 pin, 330 mil SOIC provides sockets with gold plated contacts for direct connection to a separate SNAPHAT housing containing the battery. The SNAPHAT housing has gold plated pins which mate with the sockets, ensuring reliable connection. The housing is keyed to prevent improper insertion. This unique design allows the SNAPHAT battery package to be mounted on top of the SOIC package after the completion of the surface mount process which greatly reduces the board manufacturing process complexity of either directly soldering or inserting a battery into a soldered holder. Providing non-volatility becomes a "SNAP".

The 16 pin SOIC provides battery pins for an external user supplied battery.

Table 2. Absolute Maximum Ratings <sup>(1)</sup>

Symbol	Parameter	Value	Unit
T <sub>A</sub>	Ambient Operating Temperature	0 to 70	°C
T <sub>STG</sub>	Storage Temperature (V <sub>CC</sub> Off)	SNAPHAT SOIC -40 to 85 -55 to 125	°C
V <sub>IO</sub>	Input or Output Voltages	-0.3 to V <sub>CC</sub> +0.3	V
V <sub>CC</sub>	Supply Voltage	M40Z300 M40Z300W -0.3 to 7 -0.3 to 4.6	V
I <sub>O</sub>	Output Current	20	mA
P <sub>D</sub>	Power Dissipation	1	W

Note: 1. Stresses greater than those listed under "Absolute Maximum Ratings" may cause permanent damage to the device. This is a stress rating only and functional operation of the device at these or any other conditions above those indicated in the operational section of this specification is not implied. Exposure to the absolute maximum rating conditions for extended periods of time may affect reliability.

**CAUTION:** Negative undershoots below -0.3V are not allowed on any pin while in the Battery Back-up mode.

**CAUTION:** Do NOT wave solder SOIC to avoid damaging SNAPHAT sockets.

## OPERATION

The M40Z300/W, as shown in Figure 4, can control up to four (eight, if placed in parallel) standard low-power SRAMs. These SRAMs must be configured to have the chip enable input disable all other input signals. Most slow, low-power SRAMs are configured like this, however many fast SRAMs are not. During normal operating conditions, the conditioned chip enable ( $\overline{E1_{CON}}$  to  $\overline{E4_{CON}}$ ) output pins follow the chip enable ( $\overline{E}$ ) input pin with timing shown in Table 7. An internal switch connects V<sub>CC</sub> to V<sub>OUT</sub>.

This switch has a voltage drop of less than 0.3V (I<sub>OUT1</sub>).

When V<sub>CC</sub> degrades during a power failure,  $\overline{E1_{CON}}$  to  $\overline{E4_{CON}}$  are forced inactive independent of  $\overline{E}$ . In this situation, the SRAM is unconditionally write protected as V<sub>CC</sub> falls below an out-of-tolerance threshold (V<sub>PFD</sub>). For the M40Z300 the power fail detection value associated with V<sub>PFD</sub> is selected by the Threshold Select (THS) pin and is shown in Table 6A. For the M40Z300W, the THS pin selects both the supply voltage and V<sub>PFD</sub> as shown in Table 6B.

**Note:** In either case, THS pin must be connected to either V<sub>SS</sub> or V<sub>OUT</sub>.

If chip enable access is in progress during a power fail detection, that memory cycle continues to completion before the memory is write protected. If the memory cycle is not terminated within time t<sub>WPT</sub>,  $\overline{E1_{CON}}$  to  $\overline{E4_{CON}}$  are unconditionally driven high, write protecting the SRAM. A power failure during a write cycle may corrupt data at the currently addressed location, but does not jeopardize the rest of the SRAM's contents. At voltages below V<sub>PFD</sub> (min), the user can be assured the memory will be write protected within the Write Protect Time (t<sub>WPT</sub>) provided the V<sub>CC</sub> fall time exceeds t<sub>F</sub> (See Table 7).

As V<sub>CC</sub> continues to degrade, the internal switch disconnects V<sub>CC</sub> and connects the internal battery to V<sub>OUT</sub>. This occurs at the switchover voltage (V<sub>SO</sub>). Below the V<sub>SO</sub>, the battery provides a voltage V<sub>OHB</sub> to the SRAM and can supply current I<sub>OUT2</sub> (see Table 6A/6B).

When V<sub>CC</sub> rises above V<sub>SO</sub>, V<sub>OUT</sub> is switched back to the supply voltage. Outputs  $\overline{E1_{CON}}$  to  $\overline{E4_{CON}}$  are held inactive for t<sub>CER</sub> (120ms maximum) after the power supply has reached V<sub>PFD</sub>, independent of the  $\overline{E}$  input, to allow for processor stabilization (see Figure 6).

Table 3. Truth Table

Inputs			Outputs			
$\bar{E}$	B	A	$\bar{E1}_{CON}$	$\bar{E2}_{CON}$	$\bar{E3}_{CON}$	$\bar{E4}_{CON}$
H	X	X	H	H	H	H
L	L	L	L	H	H	H
L	L	H	H	L	H	H
L	H	L	H	H	L	H
L	H	H	H	H	H	L

Table 4. AC Measurement Conditions

Input Rise and Fall Times	$\leq 5\text{ns}$
Input Pulse Voltages	0 to 3V
Input and Output Timing Ref. Voltages	1.5V

**DATA RETENTION LIFETIME CALCULATION**

Most low power SRAMs on the market today can be used with the M40Z300/W NVRAM Controller. There are, however some criteria which should be used in making the final choice of which SRAM to use. The SRAM must be designed in a way where the chip enable input disables all other inputs to the SRAM. This allows inputs to the M40Z300/W and SRAMs to be Don't Care once  $V_{CC}$  falls below  $V_{PFD}$  (min). The SRAM should also guarantee data retention down to  $V_{CC} = 2.0\text{V}$ . The chip enable access time must be sufficient to meet the system needs with the chip enable propagation delays included. If the SRAM includes a second Chip Enable pin (E2), this pin should be tied to  $V_{OUT}$ .

If data retention lifetime is a critical parameter for the system, it is important to review the data retention current specifications for the particular SRAMs being evaluated. Most SRAMs specify a data retention current at 3.0V. Manufacturers generally specify a typical condition for room temperature along with a worst case condition (generally at elevated temperatures). The system level requirements will determine the choice of which value to use. The data retention current value of the SRAMs can then be added to the  $I_{CCDR}$  value of

Figure 3. AC Testing Load Circuit

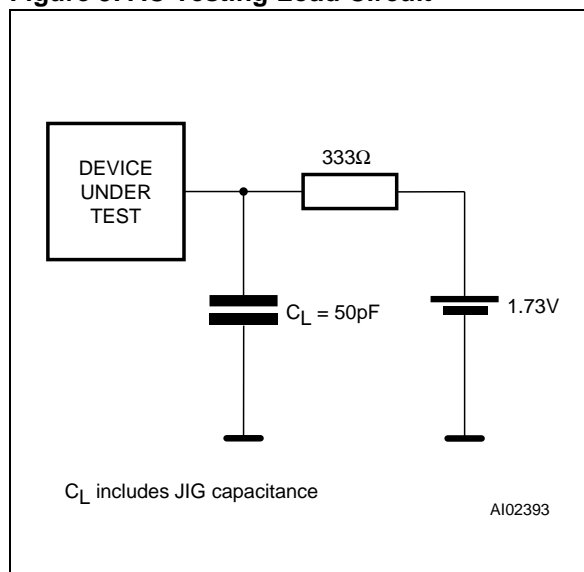

the M40Z300/W to determine the total current requirements for data retention. The available battery capacity for the SNAPHAT of your choice can then be divided by this current to determine the amount of data retention available (see Table 8).

**CAUTION:** Take care to avoid inadvertent discharge through  $V_{OUT}$  and  $\bar{E1}_{CON}$ - $\bar{E4}_{CON}$  after battery has been attached.

For a further more detailed review of lifetime calculations, please see Application Note AN1012.

Figure 4. Hardware Hookup

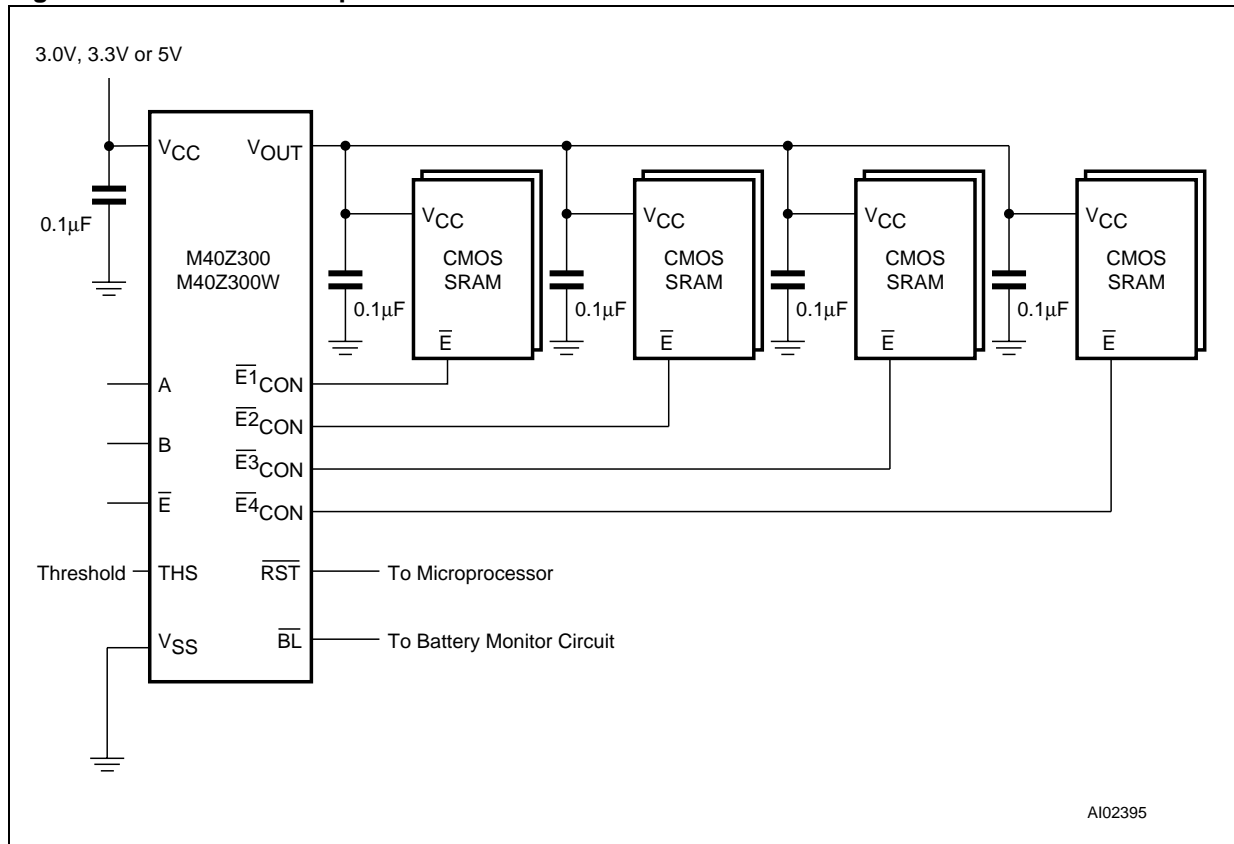

### POWER-ON RESET OUTPUT

All microprocessors have a reset input which forces them to a known state when starting. The M40Z300/W has a reset output ( $\overline{RST}$ ) pin which is guaranteed to be low within  $t_{WPT}$  of  $V_{PFD}$  (See Table 7). This signal is an open drain configuration. An appropriate pull-up resistor should be chosen to control the rise time. This signal will be valid for all voltage conditions, even when  $V_{CC}$  equals  $V_{SS}$ .

Once  $V_{CC}$  exceeds the power failure detect voltage  $V_{PFD}$ , an internal timer keeps  $\overline{RST}$  low for  $t_{REC}$  to allow the power supply to stabilize.

### TWO TO FOUR DECODE

The M40Z300/W includes a 2 input (A, B) decoder which allows the control of up to 4 independent SRAMs. The Truth Table for these inputs is shown in Table 3.

## M40Z300, M40Z300W

**Table 5. Capacitance (1)**

( $T_A = 25\text{ }^\circ\text{C}$ ,  $f = 1\text{ MHz}$ )

Symbol	Parameter	Test Condition	Min	Max	Unit
$C_{IN}$	Input Capacitance	$V_{IN} = 0V$		8	pF
$C_{OUT}$	Output Capacitance	$V_{OUT} = 0V$		10	pF

Note: 1. Sampled only, not 100% tested.

2. Outputs deselected.

**Table 6A. DC Characteristics for M40Z300**

( $T_A = 0\text{ to }70\text{ }^\circ\text{C}$ ;  $V_{CC} = 4.75V\text{ to }5.5V\text{ or }4.5V\text{ to }5.5V$ )

Symbol	Parameter	Test Condition	Min	Typ	Max	Unit
$I_{LI}$ (1)	Input Leakage Current	$0V \leq V_{IN} \leq V_{CC}$			$\pm 1$	$\mu\text{A}$
$I_{CC}$	Supply Current	Outputs open		3	6	mA
$V_{IL}$	Input Low Voltage		-0.3		0.8	V
$V_{IH}$	Input High Voltage		2.2		$V_{CC} + 0.3$	V
$V_{OL}$	Output Low Voltage	$I_{OL} = 4.0\text{mA}$			0.4	V
	Output Low Voltage (open drain) (2)	$I_{OL} = 10\text{mA}$			0.4	V
$V_{OH}$	Output High Voltage	$I_{OH} = -2.0\text{mA}$	2.4			V
$V_{OHB}$	$V_{OH}$ Battery Back-up (3)	$I_{OUT2} = -1.0\mu\text{A}$	2.0	2.9	3.6	V
$I_{OUT1}$	$V_{OUT}$ Current (Active)	$V_{OUT} > V_{CC} - 0.3$			250	mA
		$V_{OUT} > V_{CC} - 0.2$			150	mA
$I_{OUT2}$	$V_{OUT}$ Current (Battery Back-up)	$V_{OUT} > V_{BAT} - 0.3$		100		$\mu\text{A}$
$I_{CCDR}$	Data Retention Mode Current (4)				100	nA
THS	Threshold Select Voltage		$V_{SS}$		$V_{OUT}$	V
$V_{PFD}$	Power-fail Deselect Voltage (THS = $V_{SS}$ )		4.5	4.6	4.75	V
	Power-fail Deselect Voltage (THS = $V_{OUT}$ )		4.2	4.35	4.5	V
$V_{SO}$	Battery Back-up Switchover Voltage			3.0		V

Note: 1. Outputs deselected.

2. For RST & BL pins (Open Drain).

3. Chip Enable outputs ( $\overline{E1}_{CON}$  -  $\overline{E4}_{CON}$ ) can only sustain CMOS leakage currents in the battery back-up mode. Higher leakage currents will reduce battery life.

4. Measured with  $V_{OUT}$  and  $\overline{E1}_{CON}$  -  $\overline{E4}_{CON}$  open.

**Table 6B. DC Characteristics for M40Z300W**  
 ( $T_A = 0$  to  $70^\circ\text{C}$ ;  $V_{CC} = 3\text{V}$  to  $3.6\text{V}$  or  $2.7\text{V}$  to  $3.3\text{V}$ )

Symbol	Parameter	Test Condition	Min	Typ	Max	Unit
$I_{LI}$ <sup>(1)</sup>	Input Leakage Current	$0\text{V} \leq V_{IN} \leq V_{CC}$			$\pm 1$	$\mu\text{A}$
$I_{CC}$	Supply Current	Outputs open		2	4	mA
$V_{IL}$	Input Low Voltage		-0.3		0.8	V
$V_{IH}$	Input High Voltage		2.0		$V_{CC} + 0.3$	V
$V_{OL}$	Output Low Voltage	$I_{OL} = 4.0\text{mA}$			0.4	V
	Output Low Voltage (open drain) <sup>(2)</sup>	$I_{OL} = 10\text{mA}$			0.4	V
$V_{OH}$	Output High Voltage	$I_{OH} = -2.0\text{mA}$	2.4			V
$V_{OHB}$	$V_{OH}$ Battery Back-up <sup>(3)</sup>	$I_{OUT2} = -1.0\mu\text{A}$	2.0	2.9	3.6	V
$I_{OUT1}$	$V_{OUT}$ Current (Active)	$V_{OUT} > V_{CC} - 0.3$			150	mA
		$V_{OUT} > V_{CC} - 0.2$			100	mA
$I_{OUT2}$	$V_{OUT}$ Current (Battery Back-up)	$V_{OUT} > V_{BAT} - 0.3$		100		$\mu\text{A}$
$I_{CCDR}$	Data Retention Mode Current <sup>(4)</sup>				100	nA
THS	Threshold Select Voltage		$V_{SS}$		$V_{OUT}$	V
$V_{PFD}$	Power-fail Deselect Voltage (THS = $V_{SS}$ )		2.8	2.9	3.0	V
	Power-fail Deselect Voltage (THS = $V_{OUT}$ )		2.5	2.6	2.7	V
$V_{SO}$	Battery Back-up Switchover Voltage			2.5		V

Note: 1. Outputs deselected.

2. For RST & BL pins (Open Drain).

3. Chip Enable outputs ( $\overline{E1}_{CON}$  -  $\overline{E4}_{CON}$ ) can only sustain CMOS leakage currents in the battery back-up mode. Higher leakage currents will reduce battery life.

4. Measured with  $V_{OUT}$  and  $\overline{E1}_{CON}$  -  $\overline{E4}_{CON}$  open.

**Table 7. Power Down/Up AC Characteristics**  
 (T<sub>A</sub> = 0 to 70°C)

Symbol	Parameter	Min	Max	Unit	
t <sub>F</sub> <sup>(1)</sup>	V <sub>PFD</sub> (max) to V <sub>PFD</sub> (min) V <sub>CC</sub> Fall Time	300		μs	
t <sub>FB</sub> <sup>(2)</sup>	V <sub>PFD</sub> (min) to V <sub>SS</sub> V <sub>CC</sub> Fall Time	150		μs	
t <sub>R</sub>	V <sub>PFD</sub> (min) to V <sub>PFD</sub> (max) V <sub>CC</sub> Rise Time	10		μs	
t <sub>EDL</sub>	Chip Enable Propagation Delay Low	M40Z300		12	ns
		M40Z300W		20	ns
t <sub>EDH</sub>	Chip Enable Propagation Delay High	M40Z300		10	ns
		M40Z300W		20	ns
t <sub>AS</sub>	A, B set up to $\bar{E}$	0		ns	
t <sub>CER</sub>	Chip Enable Recovery	40	120	ms	
t <sub>REC</sub>	V <sub>PFD</sub> (max) to $\overline{RST}$ High	40	120	ms	
t <sub>WPT</sub>	Write Protect Time	M40Z300	40	150	μs
		M40Z300W	40	250	μs
t <sub>RB</sub>	V <sub>SS</sub> to V <sub>PFD</sub> (min) V <sub>CC</sub> Rise Time	1		μs	

Note: 1. V<sub>PFD</sub> (max) to V<sub>PFD</sub> (min) fall time of less than t<sub>F</sub> may result in deselection/write protection not occurring until 200 μs after V<sub>CC</sub> passes V<sub>PFD</sub> (min)..  
 2. V<sub>PFD</sub> (min) to V<sub>SS</sub> fall time of less than t<sub>FB</sub> may cause corruption of RAM data.

### BATTERY LOW PIN

The M40Z300/W automatically performs battery voltage monitoring upon power-up, and at factory-programmed time intervals of at least 24 hours. The Battery Low ( $\overline{BL}$ ) pin will be asserted if the battery voltage is found to be less than approximately 2.5V. The  $\overline{BL}$  pin will remain asserted until completion of battery replacement and subsequent battery low monitoring tests, either during the next power-up sequence or the next scheduled 24-hour interval.

If a battery low is generated during a power-up sequence, this indicates that the battery is below 2.5V and may not be able to maintain data integrity in the SRAM. Data should be considered suspect, and verified as correct. A fresh battery should be installed.

If a battery low indication is generated during the 24-hour interval check, this indicates that the battery is near end of life. However, data is not compromised due to the fact that a nominal V<sub>CC</sub> is supplied. In order to insure data integrity during subsequent periods of battery back-up mode, the battery should be replaced. SNAPHAT top should be replaced with valid V<sub>CC</sub> applied to the device.

The M40Z300/W only monitors the battery when a nominal V<sub>CC</sub> is applied to the device. Thus applications which require extensive durations in the battery back-up mode should be powered-up periodically (at least once every few months) in order for this technique to be beneficial. Additionally, if a battery low is indicated, data integrity should be verified upon power-up via a checksum or other technique. The  $\overline{BL}$  pin is an open drain output and an appropriate pull-up resistor to V<sub>CC</sub> should be chosen to control the rise time.



Figure 5. Power Down Timing

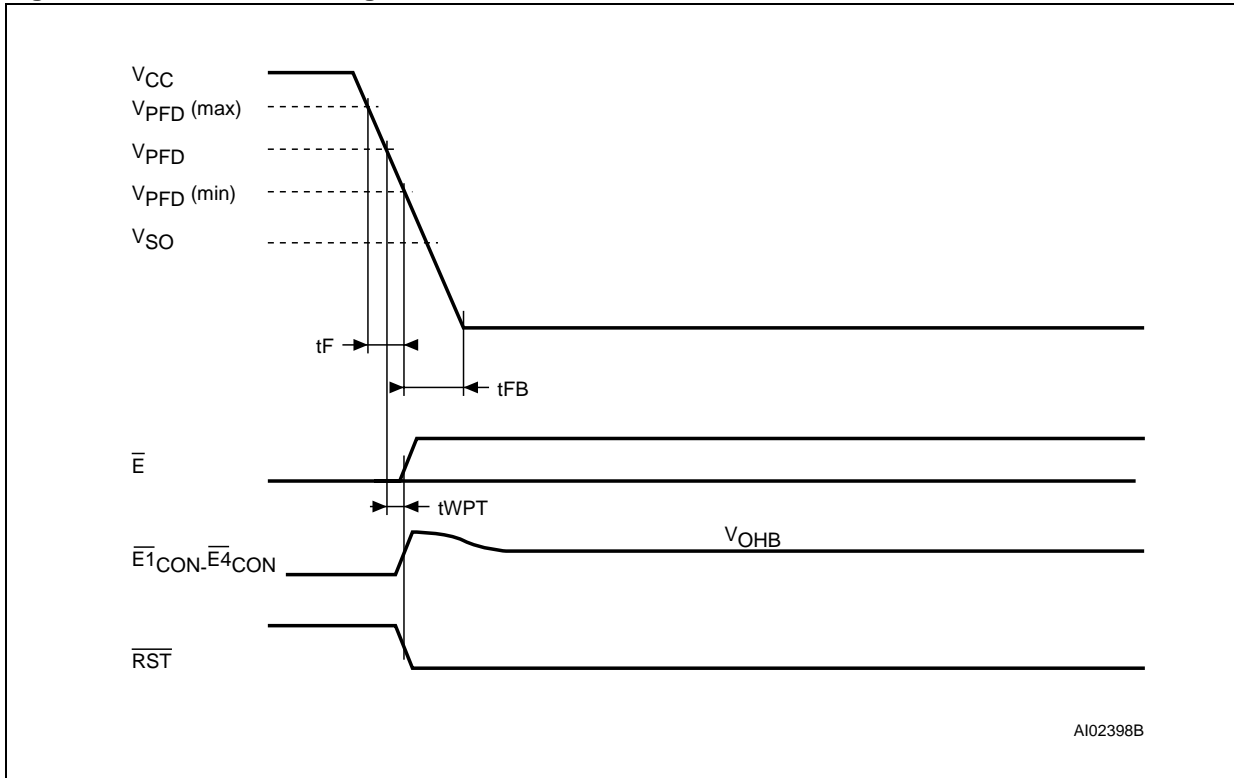

Figure 6. Power Up Timing

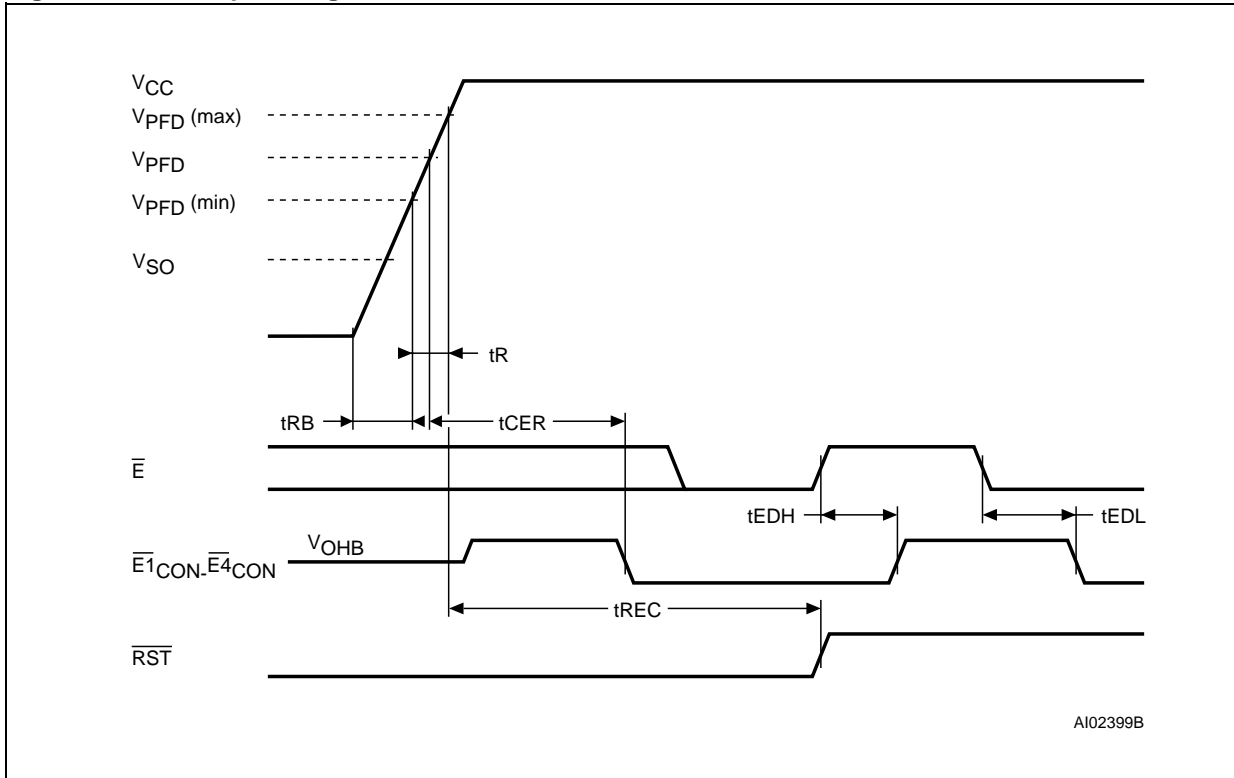
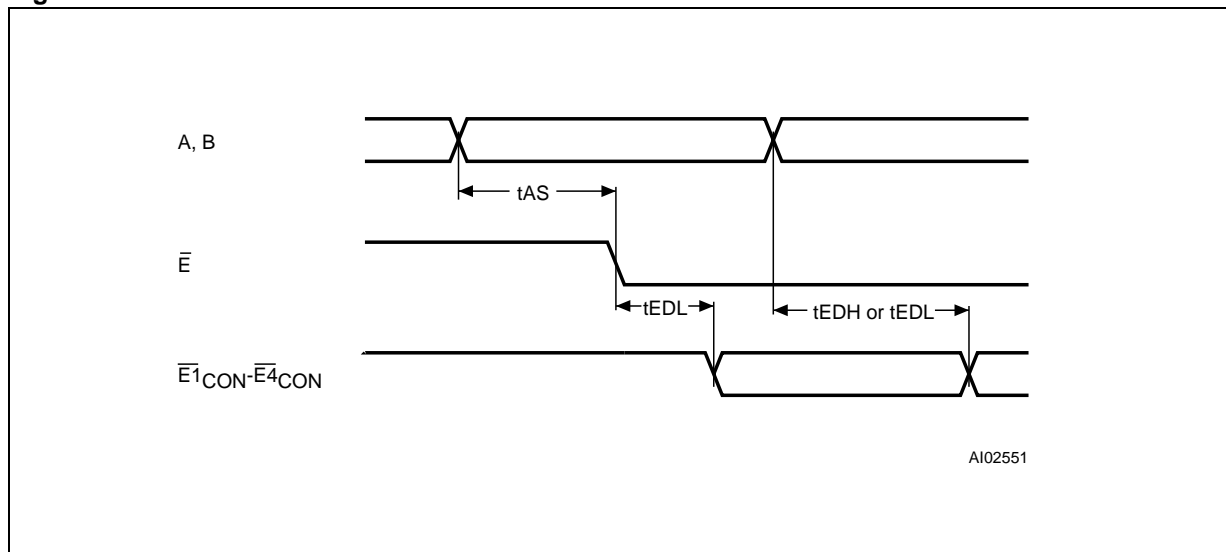

Figure 7. Address-Decode Time



Note: During system design, compliance with the SRAM timing parameters must comprehend the propagation delay between  $\bar{E}$  and  $\bar{E}_{CON}$

Table 8. Battery Table

Part Number	Description	Package
M4Z28-BR00SH	Lithium Battery (48mAh) SNAPHAT	SH
M4Z32-BR00SH	Lithium Battery (120mAh) SNAPHAT	SH

**V<sub>CC</sub> NOISE AND NEGATIVE GOING TRANSIENTS**

I<sub>CC</sub> transients, including those produced by output switching, can produce voltage fluctuations, resulting in spikes on the V<sub>CC</sub> bus. These transients can be reduced if capacitors are used to store energy, which stabilizes the V<sub>CC</sub> bus. The energy stored in the bypass capacitors will be released as low going spikes are generated or energy will be absorbed when overshoots occur.

A ceramic bypass capacitor value of 0.1μF (as shown in figure 8) is recommended in order to provide the needed filtering.

In addition to transients that are caused by normal SRAM operation, power cycling can generate negative voltage spikes on V<sub>CC</sub> that drive it to values below V<sub>SS</sub> by as much as one volt. These negative spikes can cause data corruption in the SRAM while in battery backup mode. To protect from these voltage spikes, STMicroelectronics recommends connecting a schottky diode from V<sub>CC</sub> to V<sub>SS</sub> (cathode connected to V<sub>CC</sub>, anode to V<sub>SS</sub>). Schottky diode 1N5817 is recommended for through hole and MBRS120T3 is recommended for surface mount.

Figure 8. Supply Voltage Protection

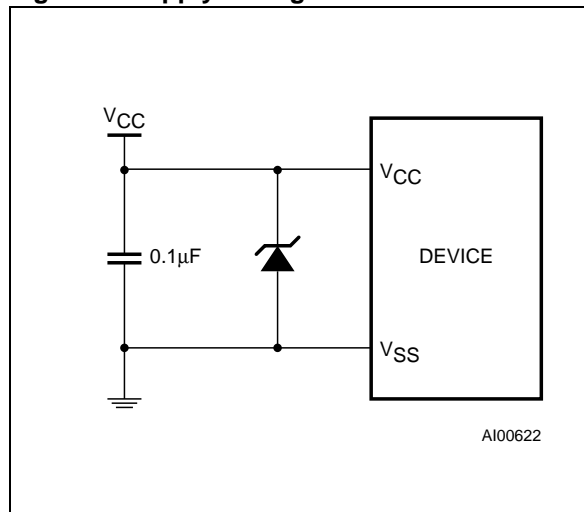

**Table 9. Ordering Information Scheme**

Example:	M40Z300W	MH	1	TR
<b>Supply Voltage and Write Protect Voltage</b>				
300	= V <sub>CC</sub> = 4.5V to 5.5V			
	THS = V <sub>SS</sub> 4.5V ≤ V <sub>PFD</sub> ≤ 4.75V			
	THS = V <sub>OUT</sub> 4.2V ≤ V <sub>PFD</sub> ≤ 4.5V			
300W	= V <sub>CC</sub> = 3.0V to 3.6V			
	THS = V <sub>SS</sub> 2.8V ≤ V <sub>PFD</sub> ≤ 3.0V			
	V <sub>CC</sub> = 2.7V to 3.3V			
	THS = V <sub>OUT</sub> 2.5V ≤ V <sub>PFD</sub> ≤ 2.7V			
<b>Package</b>				
MH <sup>(1,2)</sup>	= SOH28			
MQ	= SO16			
<b>Temperature Range</b>				
1	= 0 to 70 °C			
<b>Shipping Method for SOIC</b>				
blank	= Tubes			
TR	= Tape & Reel			

- Note: 1. The SOIC package (SOH28) requires the battery package (SNAPHAT) which is ordered separately under the part number "M4Zxx-BR00SH1" in plastic tube or "M4Zxx-BR00SH1TR" in Tape & Reel form.  
 2. Delivery may include either the 2-pin version of the SOIC/SNAPHAT or the 4-pin version of the SOIC/SNAPHAT. Both are functionally equivalent (see package drawing section for details).
- Caution:** Do not place the SNAPHAT battery package "M4Zxx-BR00SH1" in conductive foam since will drain the lithium button-cell battery.

For a list of available options (Speed, Package, etc...) or for further information on any aspect of this device, please contact the ST Sales Office nearest to you.

**Table 10. Revision History**

Date	Revision Details
March 1999	First Issue
03/08/00	Document Layout changed SO16 package added Battery Capacity changed (Table 8)

**M40Z300, M40Z300W**

**Table 11. SOH28 - 28 lead Plastic Small Outline, battery SNAPHAT, Package Mechanical Data**

Symb	mm			inches		
	Typ	Min	Max	Typ	Min	Max
A			3.05			0.120
A1		0.05	0.36		0.002	0.014
A2		2.34	2.69		0.092	0.106
B		0.36	0.51		0.014	0.020
C		0.15	0.32		0.006	0.012
D		17.71	18.49		0.697	0.728
E		8.23	8.89		0.324	0.350
e	1.27	-	-	0.050	-	-
eB		3.20	3.61		0.126	0.142
H		11.51	12.70		0.453	0.500
L		0.41	1.27		0.016	0.050
$\alpha$		0°	8°		0°	8°
N	28			28		
CP			0.10			0.004

**Figure 9. SOH28 - 28 lead Plastic Small Outline, 4-socket battery SNAPHAT, Package Outline**

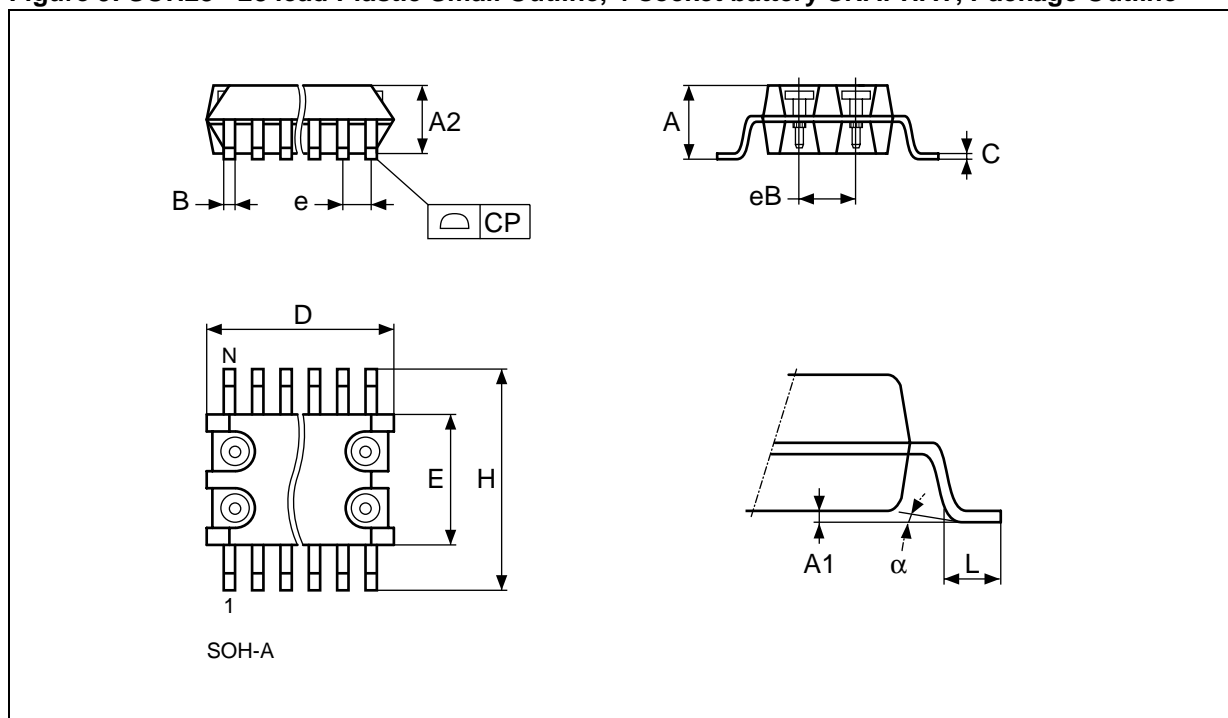

Drawing is not to scale.

Table 12. M4Z28-BR00SH SNAPHAT Housing for 48 mAh Battery, Package Mechanical Data

Symb	mm			inches		
	Typ	Min	Max	Typ	Min	Max
A			9.78			0.385
A1		6.73	7.24		0.265	0.285
A2		6.48	6.99		0.255	0.275
A3			0.38			0.015
B		0.46	0.56		0.018	0.022
D		21.21	21.84		0.835	0.860
E		14.22	14.99		0.560	0.590
eA		15.55	15.95		0.612	0.628
eB		3.20	3.61		0.126	0.142
L		2.03	2.29		0.080	0.090

Figure 10. M4Z28-BR00SH SNAPHAT Housing for 48 mAh Battery, Package Outline

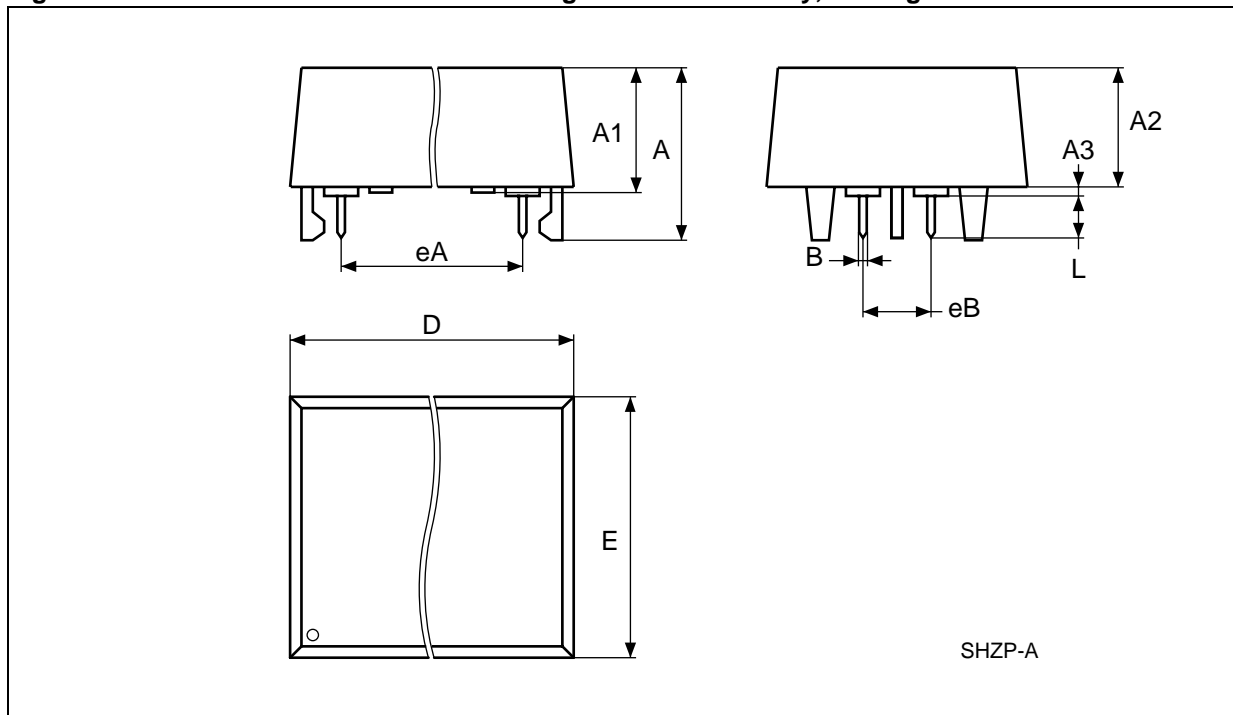

Drawing is not to scale.

**M40Z300, M40Z300W**

**Table 13. M4Z32-BR00SH SNAPHAT Housing for 120 mAh Battery, Package Mechanical Data**

Symb	mm			inches		
	Typ	Min	Max	Typ	Min	Max
A			10.54			0.415
A1		8.00	8.51		0.315	.0335
A2		7.24	8.00		0.285	0.315
A3			0.38			0.015
B		0.46	0.56		0.018	0.022
D		21.21	21.84		0.835	0.860
E		17.27	18.03		0.680	.0710
eA		15.55	15.95		0.612	0.628
eB		3.20	3.61		0.126	0.142
L		2.03	2.29		0.080	0.090

**Figure 11. M4Z32-BR00SH SNAPHAT Housing for 120 mAh Battery, Package Outline**

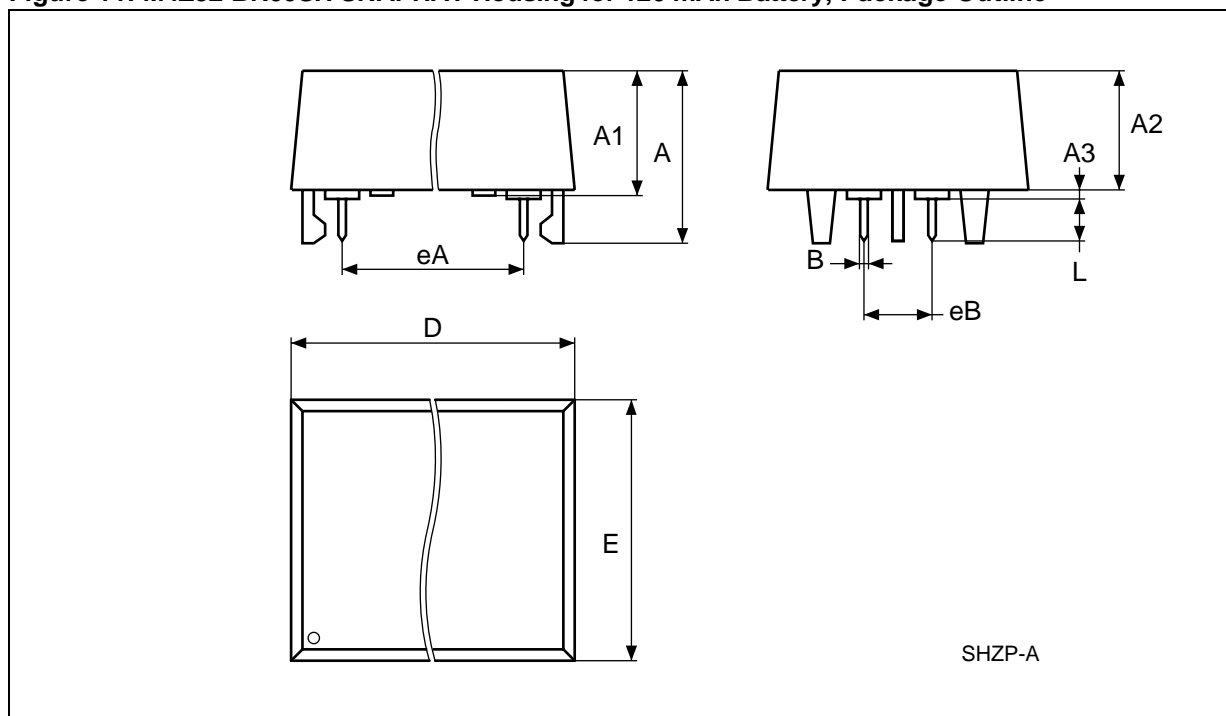

Drawing is not to scale.

Table 14. SO16 - 16 lead Plastic Small Outline, 300 mils body width

Symb.	mm			inches		
	Typ.	Min.	Max.	Typ.	Min.	Max.
A			2.59			0.102
A1		0.10	0.30		0.004	0.012
B		0.38	0.51		0.015	0.020
C		0.23	0.25		0.009	0.010
D		10.11	10.49		0.398	0.413
E		7.44	7.54		0.293	0.297
e	1.27	–	–	0.050	–	–
H		10.16	10.41		0.400	0.410
h	0.38			0.015		
L		0.41	1027		0.016	0.050
$\alpha$		0°	8°		0°	8°
N	16			16		
CP			0.10			0.004

Figure 12. SO16 - 16 lead Plastic Small Outline, 300 mils body width, Package Outline

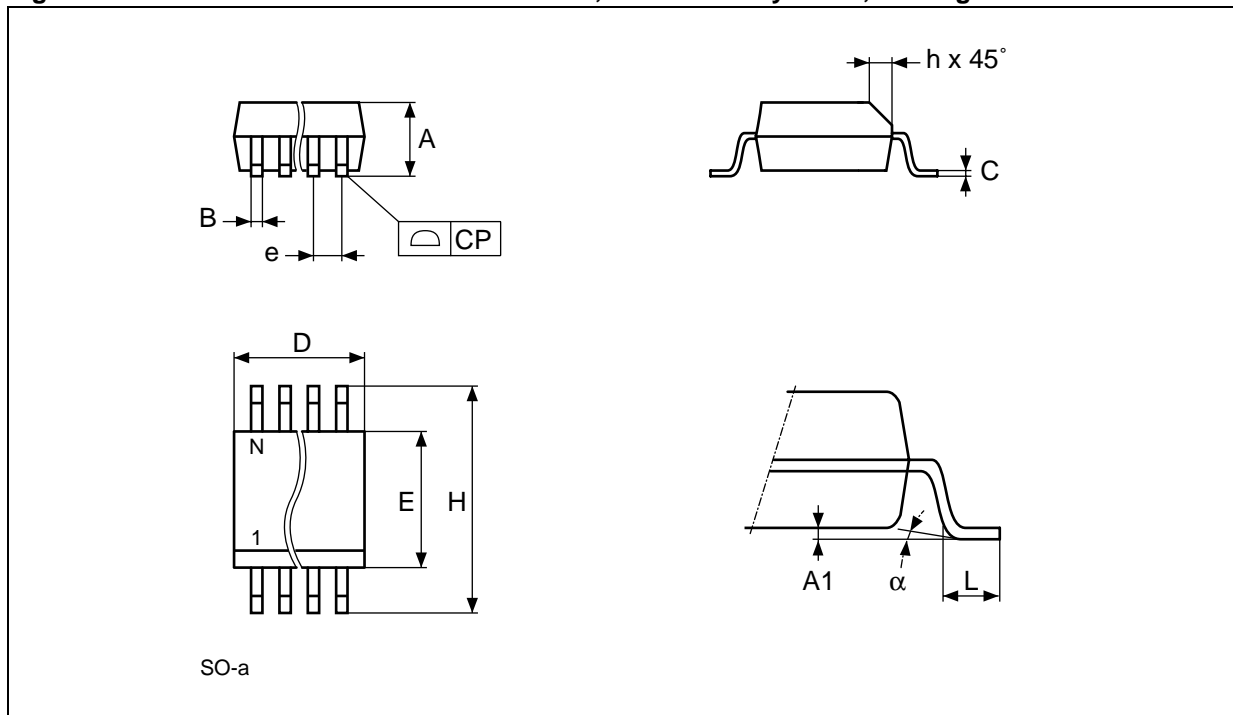

Drawing is not to scale.

Information furnished is believed to be accurate and reliable. However, STMicroelectronics assumes no responsibility for the consequences of use of such information nor for any infringement of patents or other rights of third parties which may result from its use. No license is granted by implication or otherwise under any patent or patent rights of STMicroelectronics. Specifications mentioned in this publication are subject to change without notice. This publication supersedes and replaces all information previously supplied. STMicroelectronics products are not authorized for use as critical components in life support devices or systems without express written approval of STMicroelectronics.

The ST logo is registered trademark of STMicroelectronics  
© 2000 STMicroelectronics - All Rights Reserved

All other names are the property of their respective owners.

STMicroelectronics GROUP OF COMPANIES  
Australia - Brazil - China - Finland - France - Germany - Hong Kong - India - Italy - Japan - Malaysia - Malta - Morocco -  
Singapore - Spain - Sweden - Switzerland - United Kingdom - U.S.A.

<http://www.st.com>