



L7200

MOZART, 12V DISK DRIVE SPINDLE & VCM, POWER & CONTROL "COMBO"

PRODUCT PREVIEW

GENERAL

- 12V (+/- 10%) OPERATION.
- REGISTER BASED ARCHITECTURE
- MINIMUM EXTERNAL COMPONENTS
- BCD TECHNOLOGY

VCM DRIVER

- 1.7A DRIVE CAPABILITY
- 0.75Ω TOTAL BRIDGE IMPEDANCE AT 125°C
- LINEAR MODE
- PHASE SHIFT MODULATION (PWM MODE)
- INSTANTANEOUS, (GLICH FREE) SWITCH BETWEEN THE 2 MODES.
- CLASS AB OUTPUT DRIVERS
- ZERO CROSSOVER DISTORSION
- 14 BIT DAC DEFINE OUTPUT CURRENT
- SELECTABLE TRANSCONDUCTANCE
- RAMP LOADING & PARKING VOLTAGE
- FULL INTERNAL VCM CALIBRATION
- DYNAMIC BRAKE

SPINDLE DRIVER

- 2.5A DRIVE CAPABILITY
- 0.75Ω TOTAL BRIDGE IMPEDANCE AT 125°C
- SMOOTHDRIVE™ ARCHITECTURE
- SINUSOIDAL DRIVING, VOLTAGE MODE
- BIPOLEAR DRIVING
- BEMF, INTERNAL OR EXTERNAL, PROCESSING
- SENSOR-LESS MOTOR COMMUTATION
- PROGRAMMABLE COMMUTATION DELAY
- FIXED FREQUENCY PWM OPERATION MODE
- INTERNAL FREQUENCY LOCKED LOOP SPEED CONTROL (FLL)
- PROGRAMMABLE DIGITAL FILTER FOR SPEED CONTROL LOOP
- BEMF RECTIFICATION DURING RETRACT
- BUILT-IN INDUCTIVE SENSING START UP
- DYNAMIC & REVERSE BRAKE
- BACK ROTATION DETECTION

MULTIPOWER BCD TECHNOLOGY

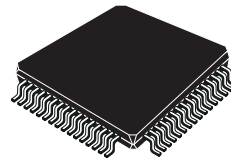

TQFP64
ORDERING NUMBER: L7200

OTHER FUNCTIONS

- 12V, 5V, 3.3V AND 2.5V MONITORING WITH POSSIBLE EXTERNAL SET TRIP POINTS AND HYSTERESIS
- POWER UP/DOWN SEQUENCING
- 8V, 3.3V AND 2.5V POSITIVE REGULATORS
- 3.3V LOGIC COMPATIBILITY
- SHOCK SENSOR DETECTOR
- INTERNAL POR DELAY TIME AT POWER ON (80ms)
- INTERNAL ISOFET FOR BEMF RECTIFICATION
- THERMAL SHUTDOWN AND PRETHERMAL WARNING

DESCRIPTION

The L7200 Mozart integrates into a single chip both spindle and VCM controllers as well as power stages. The device is designed for 12V disk drive application requiring up to 2.5A of spindle and 1.7A of VCM peak currents. The device is based on the sinusoidal driving of the spindle motor. This is realized digitally by the SMOOTHDRIVE™ SYSTEM.

A serial port with up to 40 MHz capability provides easy interface to the microprocessor. A register controlled Frequency Locked Loop (FLL) allows flexibility in setting the spindle speed. Integrated BEMF processing, digital filter, digital masking, digital delay, and sequencing minimize the number of external components required.

DESCRIPTION (continued)

Power On Reset (POR) circuitry is included. Upon detection of a low voltage condition, POR is asserted, the internal registers are reset, and spindle power circuitry is tri-stated. The BEMF is rectified providing power for actuator retraction followed by dynamic spindle braking. Three Linear regulators and a Shock Sensor circuitry are also integrated.

The device is built in BCD mixed signal technology allowing dense digital/analog circuitry to be combined with a high power DMOS output stage.

BLOCK DIAGRAM

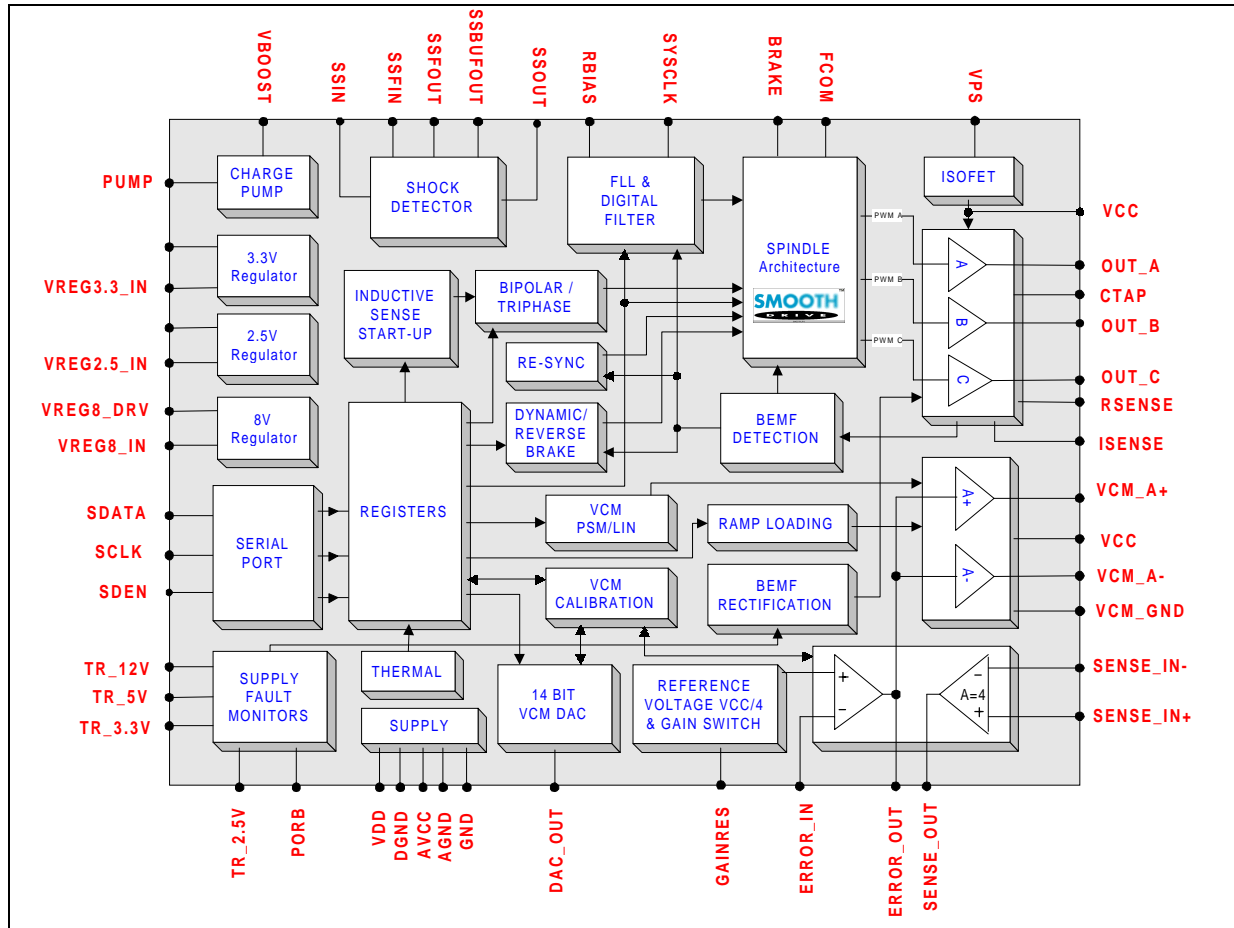

SPINDLE SMOOTHDRIVE™ ARCHITECTURE, START-UP & FLL

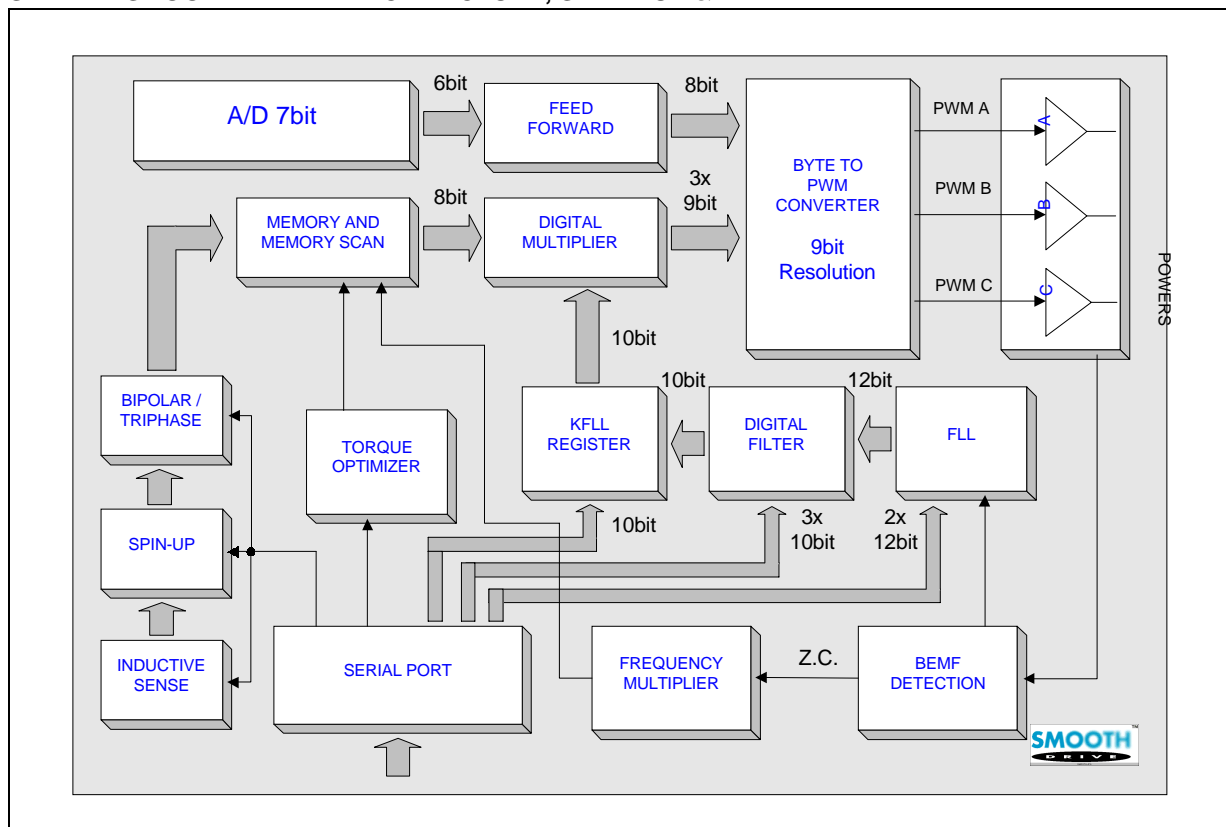

PIN CONNECTION (Top view)

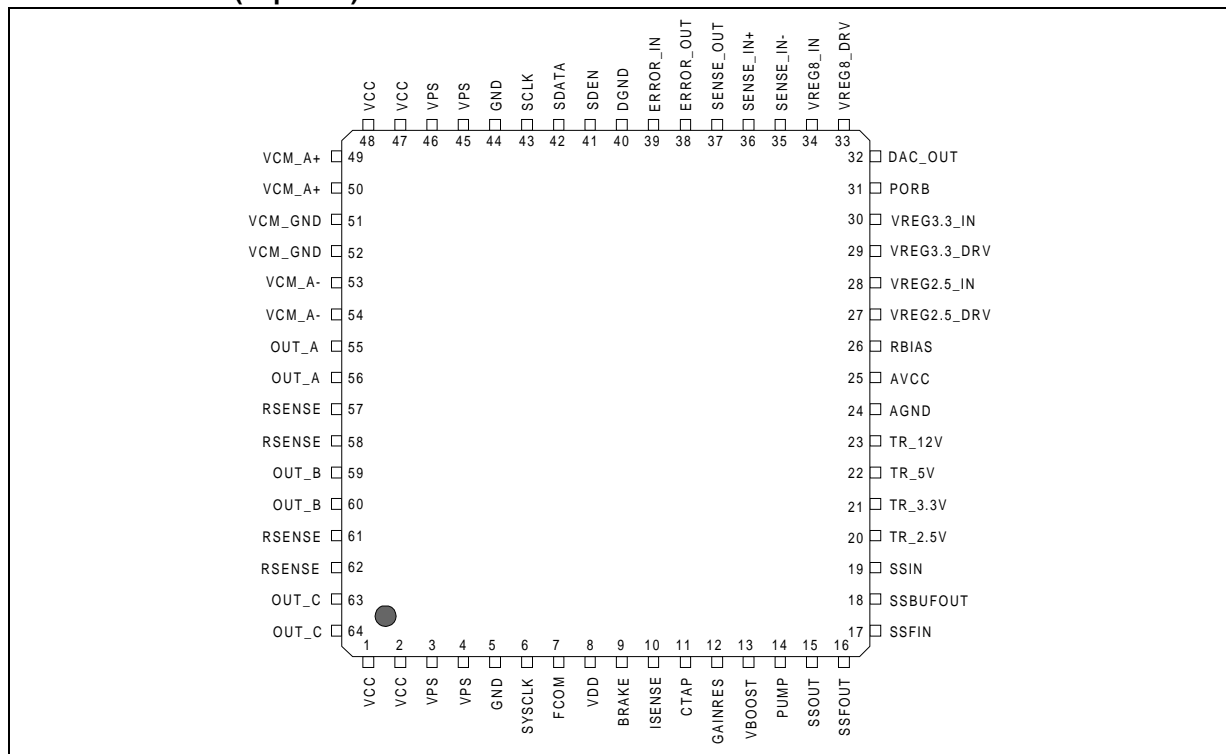

PIN FUNCTION

Pin Types: D = Digital, P = Power, A = Analog

N°	Pin Name	Description	Type
1,2	VCC	+12V Power Supply after ISOFET.	P
3,4	VPS	+12V Power Supply.	P
5	GND	Power Ground (substrate).	P
6	SYSCCLK	Clock Frequency for system timers and counters	D
7	FCOM	Output of Spindle zero crossing or Current Sense circuit	D
8	VDD	Digital +5V Supply	D
9	BRAKE	Storage capacitor for brake circuit. Typically 5.9V	A
10	ISENSE	Input to sense the voltage of the SPINDLE Sense Resistor.	A
11	CTAP	Spindle Center Tap used for Differential BEMF sensing	A
12	GAINRES	External resistor for VCM switch gain.	A
13	VBOOST	External main Charge Pump Capacitor (typically VCC+5.8V)	A
14	PUMP	External Charge Pump	A
15	SSOUT	Shock Sensor detector Digital Output	D
16	SSFOUT	Shock Sensor detector filter Output	A
17	SSFIN	Shock Sensor detector filter Input	A
18	SSBUFOUT	Shock Sensor detector amplifier Output	A
19	SSIN	Shock Sensor detector amplifier Input	A
20	TR_2.5V	Set Point Input for 2.5V Supply monitor	A
21	TR_3.3V	Set Point Input for 3.3V Supply monitor	A
22	TR_5V	Set Point Input for 5V Supply monitor	A
23	TR_12V	Set Point Input for 12V Supply monitor	A
24	AGND	Analog Ground	A
25	AVCC	+12V analog Supply (after ISOFET)	P
26	RBIAS	External resistor for setting accurate bias current	A
27	VREG2.5_DR	2.5V positive regulator drive output	A
28	VREG2.5_IN	2.5V positive regulator sense input	A
29	VREG3.3_DRV	3.3V positive regulator drive output	A
30	VREG3.3_IN	3.3V positive regulator sense input	A
31	PORB	Power On Reset Output	A
32	DAC_OUT	Output of VCM DAC	A
33	VREG8_DRV	8V positive regulator drive output	A

PIN FUNCTION (continued)

N°	Pin Name	Description	Type
34	VREG8_IN	8V positive regulator sense input	A
35	SENSE_IN-	Inverting Input of the Sense Amplifier	A
36	SENSE_IN+	Non inverting Input of the Sense Amplifier	A
37	SENSE_OUT	Output of the Sense Amplifier	A
38	ERROR_OUT	Output of the Error Amplifier	A
39	ERROR_IN	Inverting Input of the Error Amplifier	A
40	DGND	Digital Ground	D
41	SDEN	Serial Data Enable. Active high input pin for serial port enable	D
42	SDATA	Serial port Data input/output	D
43	SCLK	Serial Port Data Clock. Positive edge triggered clock input for serial data	D
44	GND	Power Ground (substrate).	P
45,46	VPS	+12V Power Supply.	P
47,48	VCC	+12V Power Supply after ISOFET.	P
49,50	VCM_A+	VCM Power Amplifier positive Output terminal.	A
51,52	VCM_GND	Ground for VCM power section.	A
53,54	VCM_A-	VCM Power Amplifier negative Output terminal.	A
55,56	OUT_A	Spindle DMOS half bridge Output and Input A for BEMF sensing.	A
57,58	RSENSE	Output Connection for the Motor Current Sense Resistor to ground.	A
59,60	OUT_B	Spindle DMOS half bridge Output and Input B for BEMF sensing.	A
61,62	RSENSE	Output Connection for the Motor Current Sense Resistor to ground.	A
63,64	OUT_C	Spindle DMOS half bridge Output and Input C for BEMF sensing.	A

ABSOLUTE MAXIMUM RATINGS

Symbol	Parameter	Value	Unit
Vcc	Maximum Supply voltage	-0.5 to 14	Volts
Vdd	Maximum Logic supply	-0.5 to 6	Volts
Vin max	Maximum digital input voltage	Vdd + .3 volts	Volts
Vin min	Minimum digital input voltage	GND - .3 volts	Volts
SPINDLE Ipeak	Spindle peak sink/source output current	2.6	Amps
VCM Ipeak	VCM peak sink/source output current	1.8	Amps

L7200

THERMAL DATA

Symbol	Parameter	Value	Unit
$\theta(jc)$	Thermal resistance Junction to case	≈ 11	$^{\circ}\text{C}/\text{Watt}$
$\theta(ja)^*$	Thermal resistance Junction to ambient	≈ 40	$^{\circ}\text{C}/\text{Watt}$
Ptot*	Maximum Total Power Dissipation	≈ 2.0	Watt
Tstg, Tj	Maximum storage/junction temperature	-40 to 150	$^{\circ}\text{C}$

* In typical application with multilayer 120x120mm Printed Circuit Board.

RECOMMENDED OPERATING CONDITIONS

Symbol	Parameter	Value	Unit
Vdd	Supply Voltage	10.8 to 13.2	V
Vcc	Logic Supply Voltage	4.5 to 5.5	V
Tamb	Operating Ambient Temperature	0 to 70	$^{\circ}\text{C}$
Tj	Junction Temperature	0 to 125	$^{\circ}\text{C}$

ELECTRICAL CHARACTERISTICS

All specifications are for $0 < T_{amb} < 70^{\circ}\text{C}$, $V_{CC}=12\text{V}$, $V_{DD}=5\text{V}$, unless otherwise noted.

Symbol	Parameter	Test Condition	Min.	Typ.	Max.	Unit
POWER SUPPLIES						
V _{cc}	12V supply		10.8		13.2	V
I _{vcc}	V _{cc} Current	SPINDLE + VCM		TBD		mA
		SPINDLE ONLY		TBD		mA
		VCM ONLY		TBD		mA
V _{rectified}	V _{cc} supply rectified		3.5		13.2	V
V _{dd}	5V supply		4.5		5.5	V
I _{vdd}	5V supply	SPINDLE + VCM		TBD		mA
		SPINDLE ONLY		TBD		mA
		VCM ONLY		TBD		mA
THERMAL SENSING						
T _{SD}	SHUTDOWN TEMPERATURE		150		180	$^{\circ}\text{C}$
T _{HYS}	HYSTERESIS			60		$^{\circ}\text{C}$
T _{EW}	EARLY WARNING			TSD-25		$^{\circ}\text{C}$

ELECTRICAL CHARACTERISTICS (continued)

Symbol	Parameter	Test Condition	Min.	Typ.	Max.	Unit
SUPPLY MONITOR						
V _{TR}	TRIP POINT 2.5V-3.3V-5V-12V	INPUT RISING	1.20	1.25	1.30	V
V _{HYS}	HYSTERESIS VOLTAGE	INPUT FALLING		25		mV
R _{on_por}	PORB PULL DOWN Ron	V _{dd} > 2V and sink 1mA			500	W
T _{PorDly}	POR Delay Time			80		mSec
12VTR	Minimum Voltage 12V		8.6			V
5VTR	Minimum Voltage 5V		4.2			V
3.3VTR	Minimum Voltage 3.3V		3.135			V
2.5VTR	Minimum Voltage 2.5V		2.375			V
VOLTAGE BOOST						
V _{BOOST}	OUTPUT VOLTAGE		V _{CC} +5		V _{CC} +6.3	V
F _{OSC}	INTERNAL OSCILLATOR			200		KHz
SW1 OUTPUT						
V _{IH}	INPUT LOGIC "1"		2.4			V
V _{IL}	INPUT LOGIC "0"				0.5	V
V _{OH}	OUTPUT LOGIC "1"	ISOURCE = 20μA	V _{dd} -0.2			V
V _{OL}	OUTPUT LOGIC "0"	ISOURCE = -400μA			0.4	V
F _{SYSClk}	SYSTEM CLOCK			20	25	MHz
VCM, DAC						
	RESOLUTION			14		BITS
	DIFFERENTIAL LINEARITY	1 LSB Change - Tested - By design	-1 -0.5		1 0.5	LSB
	INTEGRAL LINEARITY		9			BITS
	MIDSCALE OFFSET	REFERENCED TO V _{CC} /4	-5		5	mV
T _C	CONVERTION TIME				5	μs
	FULL SCALE VOLTAGE	REFERENCED TO V _{CC} /4		±1		V
	FULL SCALE ERROR		-6		6	%
VCM, ERROR AMPLIFIER						
AVOL	OPEN LOOP GAIN	DC		80		dB
VOS	INPUT OFFSET VOLTAGE			1		mV

ELECTRICAL CHARACTERISTICS (continued)

Symbol	Parameter	Test Condition	Min.	Typ.	Max.	Unit
V _{ICM}	INPUT COMMON MODE RANGE			V _{CC} /4 +/-1.5		V
F _{ODB}	UNITY GAIN BANDWIDTH			10		MHz
VCM, POWER STAGE						
R _{DS(ON)}	Output On Resistance (Each Device)	T _j = 25°C T _j = 125°C			0.25 0.35	Ω
I _o	Operating Current				1.3	A
I _{O(LEAK)}	Output Leakage Current	V _{CC} = 14V			1.0	mA
VCM, CURRENT SENSE AMPLIFIER						
A _v	Voltage Gain		3.88	4	4.12	V/V
V _{ICM}	Input Common Mode Range		-0.3		V _{CC} +0.3	V
V _{OCM}	Output Common Mode Range	-1mA < I _o < 1mA	1.5		4.5	V
V _{OS}	Output Offset Voltage	SENSE_IN(-/+) = V _{CC} /4		10		mV
F _{3dB}	3dB Bandwidth			3		MHz
CMRR	Input Common Mode Rejection Ratio		50			dB
PSRR	Power Supply Rejection Ratio		60			dB
VCM RETRACT						
V _{park}	Retract Voltage	PKV=0 & PKV1=0 & PKV2=0 PKV=1 & PKV1=0 & PKV2=0 PKV=0 & PKV1=1 & PKV2=0 PKV=1 & PKV1=1 & PKV2=0 PKV=0 & PKV1=0 & PKV2=1 PKV=1 & PKV1=0 & PKV2=1 PKV=0 & PKV1=1 & PKV2=1 PKV=1 & PKV1=1 & PKV2=1		0.30 0.60 0.90 1.20 1.50 1.80 2.10 2.40		V
T _{retract}	Retract Time limited by the internal oscillator 200KHz	RT0 = 0 & RT1 = 0 RT0 = 1 & RT1 = 0 RT0 = 0 & RT1 = 1 RT0 = 1 & RT1 = 1		80 160 320 640		ms
SPINDLE, PWM CURRENT SENSE COMPARATOR						
T _{DLY}	Delay to Fcom Out			200	500	ns
SPINDLE, POWER STAGE						
R _{DS(ON)}	Output On Resistance (each device)	T _j = 25°C T _j = 125°C			0.25 0.35	Ω
I _o	Start-up Current				2	A
I _{O(LEAK)}	Output Leakage Current	V _{CC} = 14V			1.0	mA

ELECTRICAL CHARACTERISTICS (continued)

Symbol	Parameter	Test Condition	Min.	Typ.	Max.	Unit
	Output Slew Rate (PWM)	Reg# 2.2 = 0 Reg# 2.2 = 1		10 20		V/ μ s
BEMF _{MI} N	Minimum BEMF Voltage for Detection			35		mVp-p
V _{HYS}	Hysteresis			18		mV
CURRENT SENSE AMPLIFIER						
A _v	Voltage Gain		3.8	4.0	4.2	V/V
dV _O /dt	Output Slew Rate			20		V/ μ S
3.3V LINEAR REGULATOR						
V _{3.3}	3.3V Regulation Voltage	I _{load} < 0.6A	3.15	3.3	3.45	V
A _v	Open Loop Gain			60		dB
I _{base}	Driving Base Current				20	mA
2.5V LINEAR REGULATOR						
V _{2.5}	2.5V Regulation Voltage	I _{load} < 0.6A		2.5		V
A _v	Open Loop Gain			60		dB
I _{base}	Driving Base Current				20	mA
8V LINEAR REGULATOR						
V ₈	8V Regulation Voltage	I _{load} < 0.2A		8		V
A _v	Open Loop Gain			60		dB
I _{base}	Driving Base Current				5	mA
SHOCK SENSOR - INPUT OPERATIONAL AMPLIFIER A1						
A _v	Open Loop Gain			20		dB
R _{in}	Input Impedance			10		M Ω
F _{odB}	Unity Gain Bandwidth			30		KHz
SHOCK SENSOR - FILTER OPERATIONAL AMPLIFIER A2						
A _v	Open Loop Gain			80		dB
F _{odB}	Unity Gain Bandwidth			5		KHz
V _{offset}	Offset Voltage			\pm 5		V
SHOCK SENSOR - OUTPUT WINDOW COMPARATOR						
V _H	V _{th} High	Referred to V _{cc} /4		+0.5		V
V _L	V _{th} Low	Referred to V _{cc} /4		-0.5		V

SERIAL PORT

PARAMETER	MIN.	TYP.	MAX.	UNITS
SCLK Period, (T_{SCK})	25			ns
SCLK low time, (T_{CKL})	10			ns
SCLK high time, (T_{CKH})	10			ns
Enable to SCLK (T_{SDENS})	10		15	ns
SCLK to disable (T_{SDENH})	12.5			ns
Data set-up time before rising edge SCLK (T_{DS})	5			ns
Data hold time (T_{DH})	5			ns
Minimum SDEN low time (T_{SDENL})	30			ns

Figure 1. Serial Port Timing Information

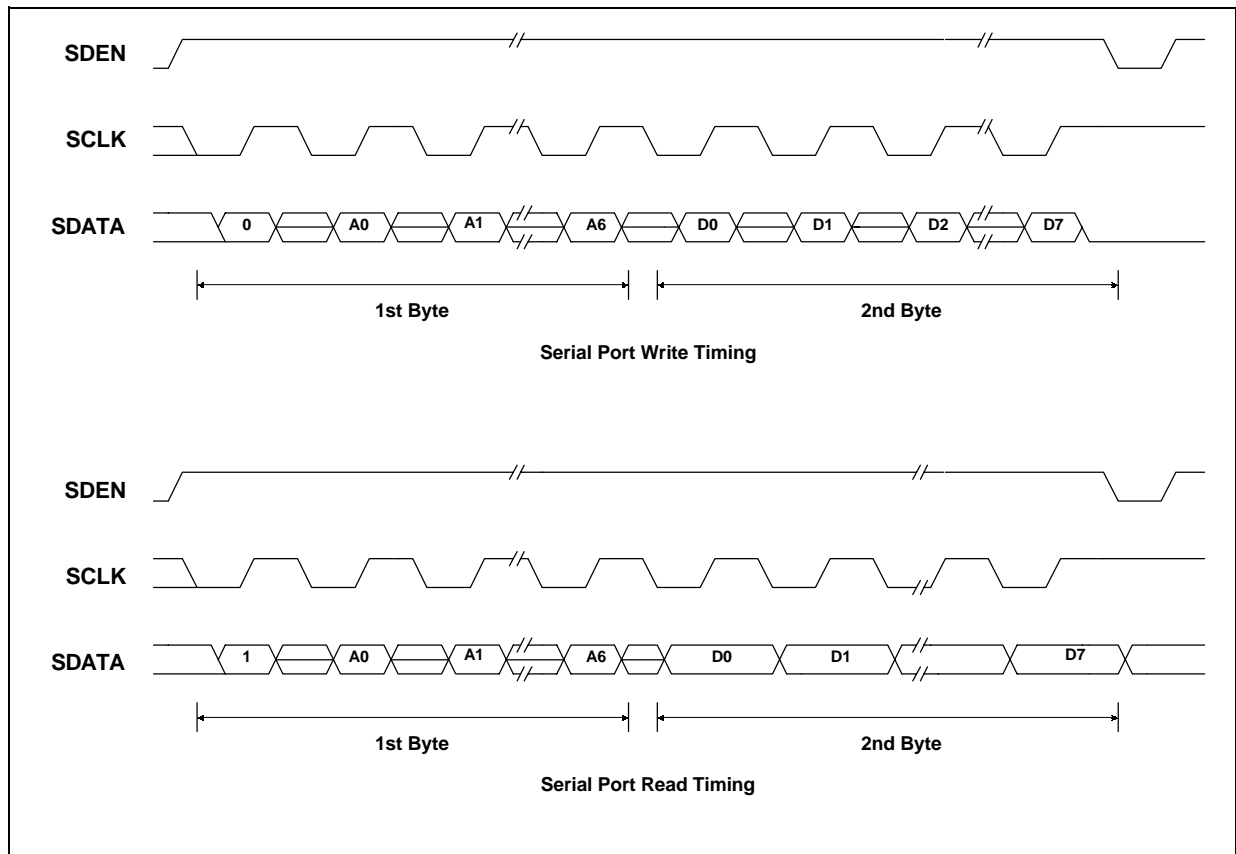

SERIAL PORT OPERATION

The serial port interface is a bi-directional port for reading and writing programming data from/to the internal registers of this device. For data transfers SDEN is brought high, serial data is presented at the SDATA pin, and a serial clock is applied to the SCLK pin. After the SDEN goes high, the first 16 pulses applied to the SCLK pin will shift the data presented at the SDATA pin into an internal shift register on the rising edge of each clock. An internal counter prevents more than 16 bits from being shifted into the register. The data in the shift register is

latched after the 16th SCLK pulse. If less than 16 clock pulses are provided before SDEN goes low, the data transfer is aborted.

All transfers are shifted into the serial port LSB first. The first byte of the transfer is for Address and Instruction information. The first bit is R/W instruction bit, 0 is for WRITE and 1 is for READ. Following 3 bits are for Combo Data Bank (all set to '1'). The last 4 bits are for Register Address.

Figure 2. Serial Port Data Transfer Format

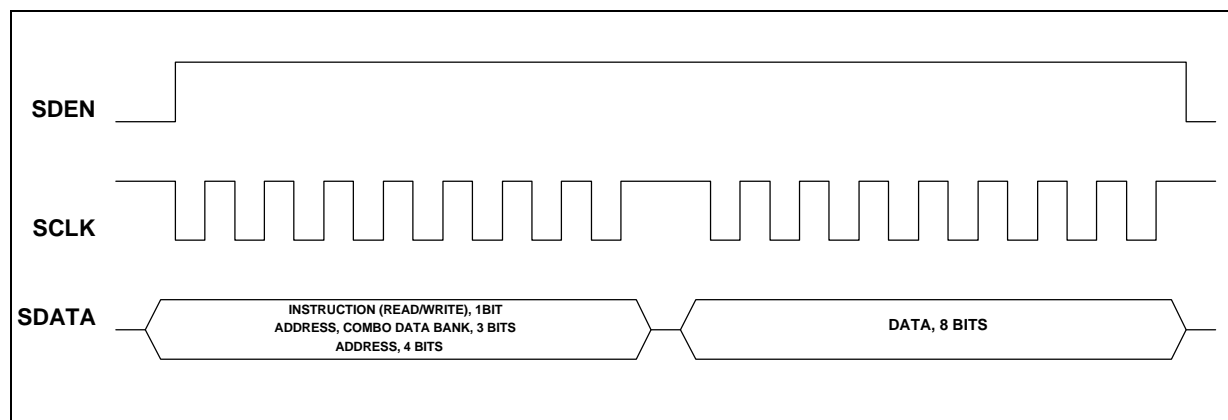

INTERNAL REGISTERS DEFINITION

Reg: 0
Name: Spindle Spin-Up Register
Type: Write only
Address: 0Eh

BIT	LABEL	DESCRIPTION			
0	START	"0" Reset and Brakes the Spindle. "1" Initiates the Spindle Start-Up procedure.			
1	EXTERNAL	"0" Spindle BEMF processing in internal mode. "1" External mode.			
2	SEQINC	In external mode, a "0" to "1" transition, increments the Spindle Sequencer.			
3	STOP	"0" Complete Internal Spindle Start-Up. "1" Stop after Inductive Sense			
4	INDSENSE	"0" Normal condition. "1" in External mode, initiate the Inductive Sense			
5	SPCOAST	"0" Spindle Outputs Enabled. "1" Disabled.			
6	SPINUPTIME 0	Spindle Internal Spin Up.	Bit 7	Bit 6	Time
		Energization Time. First Bit.	0	0	10mS
7	SPINUPTIME 1	Spindle Internal Spin Up.	0	1	20mS
		Energization Time. Second Bit.	1	0	30mS
			1	1	40mS

INTERNAL REGISTERS DEFINITION (continued)

Reg: 1 Name: Spindle Set-Up 0 Register Type: Write only Address: 1Eh					
BIT	LABEL	DESCRIPTION			
0	SMOOTH	"0" Spindle SMOOTHDRIVE™. "1" Spindle Six step drive.			
1	BIPMASK	Spindle Mask Time. "0" 15°. "1" 7.5°. (Only in six step drive).			
2	MINON 0	Minimum ON time in Current	Bit 3	Bit 2	Min TON
		limit. First Bit.	0	0	6µS
3	MINON 1	Minimum ON time in Current	0	1	3µS
		limit. Second Bit.	1	0	9µS
			1	1	7.6µS
4	BIPDELAY	Spindle Commutation Delay. "0" 30°. "1" 15°. (Only in six step drive).			
5	MASKSPIN 0	Spindle Mask at acceleration.	Bit 6	Bit 5	Mask
		First Bit.	0	0	3.2mS
6	MASKSPIN 1	Spindle Mask at acceleration.	0	1	1.6mS
		Second Bit.	1	0	0.8mS
			1	1	6.4mS
7	FREEZE	"0" Torque Optimizer Activated. "1" Torque Optimizer Frozen.			

Reg: 2 Name: Spindle Set-Up 1 Register Type: Write only Address: 2Eh					
BIT	LABEL	DESCRIPTION			
0	IL0	Current Limit and Inductive	Bit 1	Bit 0	Vlimit
		Sense thresholds. First Bit.	0	0	0.45V
1	IL1	Current Limit and Inductive	0	1	0.50V
		Sense thresholds. Second Bit.	1	0	0.55V
			1	1	0.75V
2	SSLEW	Spindle Chopping Slew Rate. "0" 10V/µS. "1" 20V/µS.			
3	FLLEXT	Spindle Speed control loop. "0" Internal. "1" External.			

INTERNAL REGISTERS DEFINITION (continued)

BIT	LABEL	DESCRIPTION
4	INDEX	External FLL update.
5	EXTK	"0" Spindle Speed internal KFLL. "1" All Reg#7 and Lsb of Reg#8 bits are mixed to allow external setting of KFLL.
6	MECH/ELEC	Electrical or Mechanical cycle for Spindle FLL control. "0" Mechanical. "1" Electrical.
7	8_12POLE	Spindle Motor Poles. "0" 8 poles. "1" 12 poles.

Reg: 3
Name: Spindle Set-Up 2 Register
Type: Write only
Address: 3Eh

BIT	LABEL	DESCRIPTION
0	ZCWINDOW	Chop cycle for Spindle ZC tristate time. "0" Two. "1" One.
1	REVBRAKE	"1" Spindle Reverse Brake. Toggling this bit will define the time before ending over normal brake. 1 = 10mS. 2 = 20mS. 3 = 40mS.
2	CLKDIV	SYSClk divider. "0" SYSClk. "1" SYSClk divide by 2.
3	DIV1.5	SYSClk divider. "0" SYSClk. "1" SYSClk divide by 1.5.
4	FLLCOARSE<0>	LSB of Spindle FLL Coarse Counter.
5	FLLCOARSE<1>	Bit 1 of Spindle FLL Coarse Counter.
6	FLLCOARSE<2>	Bit 2 of Spindle FLL Coarse Counter.
7	FLLCOARSE<3>	Bit 3 of Spindle FLL Coarse Counter.

Reg: 4
Name: Spindle FLL Coarse Register
Type: Write only
Address: 4Eh

BIT	LABEL	DESCRIPTION
0	FLLCOARSE<4>	Bit 4 of Spindle FLL Coarse Counter.
1	FLLCOARSE<5>	Bit 5 of Spindle FLL Coarse Counter.
2	FLLCOARSE<6>	Bit 6 of Spindle FLL Coarse Counter.
3	FLLCOARSE<7>	Bit 7 of Spindle FLL Coarse Counter.
4	FLLCOARSE<8>	Bit 8 of Spindle FLL Coarse Counter.
5	FLLCOARSE<9>	Bit 9 of Spindle FLL Coarse Counter.

INTERNAL REGISTERS DEFINITION (continued)

BIT	LABEL	DESCRIPTION
6	FLLCOARSE<10>	Bit 10 of Spindle FLL Coarse Counter.
7	FLLCOARSE<11>	MSB of Spindle FLL Coarse Counter.

Reg: 5
Name: Spindle FLL Fine Register
Type: Write only
Address: 5Eh

BIT	LABEL	DESCRIPTION
0	FLLFINE<0>	LSB of Spindle FLL Fine Counter.
1	FLLFINE<1>	Bit 1 of Spindle FLL Fine Counter.
2	FLLFINE<2>	Bit 2 of Spindle FLL Fine Counter.
3	FLLFINE<3>	Bit 3 of Spindle FLL Fine Counter.
4	FLLFINE<4>	Bit 4 of Spindle FLL Fine Counter.
5	FLLFINE<5>	Bit 5 of Spindle FLL Fine Counter.
6	FLLFINE<6>	Bit 6 of Spindle FLL Fine Counter.
7	FLLFINE<7>	Bit 7 of Spindle FLL Fine Counter.

Reg: 6
Name: Spindle Set-Up 3 Register
Type: Write only
Address: 6Eh

BIT	LABEL	DESCRIPTION		
0	FLLFINE<8>	Bit 8 of Spindle FLL Fine Counter.		
1	FLLFINE<9>	Bit 9 of Spindle FLL Fine Counter.		
2	FLLFINE<10>	MSB of Spindle FLL Fine Counter.		
3	COEFF_B0<8>	MSB of Spindle FLL filter coefficient B0.		
4	COEFF_B1<8>	MSB of Spindle FLL filter coefficient B1.		
5	STUCKSET	Spindle Stuck Rotor Time. "0" 400mS. "1" 100mS.		
6	CLAMP0	KFLL clamp. First Bit.		
7	CLAMP1	KFLL clamp. Second Bit.		
		Bit 7	Bit 6	Clamp
		0	0	0.50
		0	1	0.55
		1	0	0.60
		1	1	0.65

INTERNAL REGISTERS DEFINITION (continued)

Reg: 7
Name: Spindle FLL Filter Coefficient A1 Register
Type: Write only
Address: 7Eh

BIT	LABEL	DESCRIPTION
0	COEFF_A1<0>	LSB of Spindle FLL filter coefficient A1.
1	COEFF_A1<1>	Bit 1 of Spindle FLL filter coefficient A1.
2	COEFF_A1<2>	Bit 2 of Spindle FLL filter coefficient A1.
3	COEFF_A1<3>	Bit 3 of Spindle FLL filter coefficient A1.
4	COEFF_A1<4>	Bit 4 of Spindle FLL filter coefficient A1.
5	COEFF_A1<5>	Bit 5 of Spindle FLL filter coefficient A1.
6	COEFF_A1<6>	Bit 6 of Spindle FLL filter coefficient A1.
7	COEFF_A1<7>	MSB of Spindle FLL filter coefficient A1.

Reg: 8
Name: Spindle FLL Filter Coefficient B0 Register
Type: Write only
Address: 8Eh

BIT	LABEL	DESCRIPTION
0	COEFF_B0<0>	LSB of Spindle FLL filter coefficient B0.
1	COEFF_B0<1>	Bit 1 of Spindle FLL filter coefficient B0.
2	COEFF_B0<2>	Bit 2 of Spindle FLL filter coefficient B0.
3	COEFF_B0<3>	Bit 3 of Spindle FLL filter coefficient B0.
4	COEFF_B0<4>	Bit 4 of Spindle FLL filter coefficient B0.
5	COEFF_B0<5>	Bit 5 of Spindle FLL filter coefficient B0.
6	COEFF_B0<6>	Bit 6 of Spindle FLL filter coefficient B0.
7	COEFF_B0<7>	Bit 7 of Spindle FLL filter coefficient B0.

INTERNAL REGISTERS DEFINITION (continued)

Reg: 9
Name: Spindle FLL Filter Coefficient B1 Register
Type: Write only
Address: 9Eh

BIT	LABEL	DESCRIPTION
0	COEFF_B1<0>	LSB of Spindle FLL filter coefficient B1.
1	COEFF_B1<1>	Bit 1 of Spindle FLL filter coefficient B1.
2	COEFF_B1<2>	Bit 2 of Spindle FLL filter coefficient B1.
3	COEFF_B1<3>	Bit 3 of Spindle FLL filter coefficient B1.
4	COEFF_B1<4>	Bit 4 of Spindle FLL filter coefficient B1.
5	COEFF_B1<5>	Bit 5 of Spindle FLL filter coefficient B1.
6	COEFF_B1<6>	Bit 6 of Spindle FLL filter coefficient B1.
7	COEFF_B1<7>	Bit 7 of Spindle FLL filter coefficient B1.

Reg: 10
Name: Voice Coil DAC 0 Register
Type: Write only
Address: AEh

BIT	LABEL	DESCRIPTION
0	VCMDAC<0>	LSB of Voice Coil DAC.
1	VCMDAC<1>	Bit 1 of Voice Coil DAC.
2	VCMDAC<2>	Bit 2 of Voice Coil DAC.
3	VCMDAC<3>	Bit 3 of Voice Coil DAC.
4	VCMDAC<4>	Bit 4 of Voice Coil DAC.
5	VCMDAC<5>	Bit 5 of Voice Coil DAC.
6	VCMDAC<6>	Bit 6 of Voice Coil DAC.
7	VCMDAC<7>	Bit 7 of Voice Coil DAC.

INTERNAL REGISTERS DEFINITION (continued)

Reg:	11
Name:	Voice Coil DAC 1 Register
Type:	Write only
Address:	BEh

BIT	LABEL	DESCRIPTION
0	VCMDAC<8>	Bit 8 of Voice Coil DAC.
1	VCMDAC<9>	Bit 9 of Voice Coil DAC.
2	VCMDAC<10>	Bit 10 of Voice Coil DAC.
3	VCMDAC<11>	Bit 11 of Voice Coil DAC.
4	VCMDAC<12>	Bit 12 of Voice Coil DAC.
5	VCMDAC<13>	MSB of Voice Coil DAC.
6	PSM/LIN	VCM Current control. "0" Linear mode. "1" PSM mode.
7	VCMEN	"0" VCM Disabled. "1" VCM Enabled.

Reg:	12
Name:	Voice Coil Retract Register
Type:	Write only
Address:	CEh

BIT	LABEL	DESCRIPTION	Bit 2	Bit 1	Bit 0	Voltage
0	PKV0	Retract Voltage. First Bit.				
1	PKV1	Retract Voltage. Second Bit.	0	0	0	0.30V
2	PKV2	Retract Voltage. Third Bit.	0	0	1	0.60V
			0	1	0	0.90V
			0	1	1	1.20V
			1	0	0	1.50V
			1	0	1	1.80V
			1	1	0	2.10V
			1	1	1	2.40V
3	RT0	Retract Time. First Bit.	Bit 4	Bit 3		Time
4	RT1	Retract Time. Second Bit.	0	0		80ms
			0	1		160ms
			1	0		320ms
			1	1		640ms

INTERNAL REGISTERS DEFINITION (continued)

BIT	LABEL	DESCRIPTION
5	RETDIR	Retract Direction. "0" VCM- high, VCM+ low. "1" VCM- low, VCM+ high.
6	RETRACT	"1" Retracts the Voice Coil arm.
7	RETBRK	"1" Brakes the VCM for the first 20mS of the retract time then it reverses the direction of the retract opposite to the RETDIR bit setting for other 20mS, then it finish the normal retract. This total 40mS are subtracted from the programmed Retract time.

Reg: 13
Name: Voice Coil Set-Up and Ramp Loading Register
Type: Write only
Address: DEh

BIT	LABEL	DESCRIPTION					
		Bit 3	Bit2	Bit 1	Bit 0	Adj	
0	VCMCAL0	VCM Calibration. First Bit.					
1	VCMCAL1	VCM Calibration. Second Bit.					
2	VCMCAL2	VCM Calibration. Third Bit.					
3	VCMCAL3	VCM Calibration. Fourth Bit.					
		0	0	1	1	4.2mV	
		0	1	0	0	5.6mV	
		0	1	0	1	7.0mV	
		0	1	1	0	8.4mV	
		0	1	1	1	9.8mV	
		1	0	0	0	11.2mV	
		1	0	0	1	12.6mV	
		1	0	1	0	14.0mV	
		1	0	1	1	15.4mV	
		1	1	0	0	16.8mV	
		1	1	0	1	18.2mV	
		1	1	1	0	19.6mV	
		1	1	1	1	21.0mV	
4	VCMCALDIR	VCM Calibration Direction. "0" Positive offset. "1" Negative offset.					
5	RAMPLOADING	VCM Ramp Loading Setting. "1" Ramp Loading mode.					
6	SAMPLE/HOLD	VCM Ramp Loading Setting. "0" Hold. "1" Sampling.					
7	TRISTATE	VCM Ramp Loading Setting. "1" Synchronously clamps the VCM outputs until current is less than 100mA, then tristate them.					

INTERNAL REGISTERS DEFINITION (continued)

Reg: 14		
Name: System FunctionSet-Up Register		
Type: Write only		
Address: EEh		
BIT	LABEL	DESCRIPTION
0	GAINSWITCH	VCM current loop Gain Switch. "0" Switch open. "1" Switch close.
1	EXTP	VCM external mode VCMP output. "0" VCMP low. "1" VCMP high.
2	EXTN	VCM external mode VCMN output. "0" VCMN low. "1" VCMN high.
3	EXTVCM	VCM mode. "0" Internal. "1" External.
4	VBDIS	Vboost oscillatotor. "0" Enabled. "1" Disabled.
5	SHOCKEN	Schock Detector. "0" Disabled. "1" Enabled.
6		
7		

Reg: 15		
Name: Spindle Diagnostic Register		
Type: Read only		
Address: 0Fh		
BIT	LABEL	DESCRIPTION
0	LOCK	"0" Indicates Spindle Speed error (>16 μ S sample, either mechanical or electrical).
1	NOTHR	"1" Indicates that the Inductive Sense threshold is not reached.
2	PHREADY	"1" Indicates that the Phase reading of the motor succeeded.
3	STUCKROTOR	"1" Indicates that the Spindle BEMF is not detected.
4	PHASE<0>	Inductive Sense Phase detected. First Bit.
5	PHASE<1>	Inductive Sense Phase detected. Second Bit.
6	PHASE<2>	Inductive Sense Phase detected. Third Bit.
7	BACKSPIN	"1" Indicateds a Back rotation of the Spindle Motor.

INTERNAL REGISTERS DEFINITION (continued)

Reg:	16
Name:	System Diagnostic Register
Type:	Read only
Address:	1Fh

BIT	LABEL	DESCRIPTION
0	PHASEFINE<0>	Torque Optimizer Phase Shift. First Bit.
1	PHASEFINE<1>	Torque Optimizer Phase Shift. Second Bit.
2	PHASEFINE<2>	Torque Optimizer Phase Shift. Third Bit.
3	PHASEFINE<3>	Torque Optimizer Phase Shift. Fourth Bit.
4	THWARNING	Thermal Warning. "1" Indicates that the Device temperature is approximately 25°C lower than the thermal shutdown's one.
5	THSHUTDOWN	Thermal Shutdown. "1" Indicates that the Device temperature has exceeded 160°C. The bit will reset (=0) when the temperature drops below 130°C.
6	VCMCAL	Outputs of the Calibration Comparator.
7	RET	"1" Indicates that the Voice Coil is Retracting.

Reg:	17
Name:	ID Register
Type:	Read only
Address:	2Fh

BIT	LABEL	DESCRIPTION
0	ID_REV0	Device Minor Revision. First Bit.
1	ID_REV1	Device Minor Revision. Second Bit.
2	ID_REV2	Device Minor Revision. Third Bit.
3	ID_REV3	Device Minor Revision. Fourth Bit.
4	ID_REV4	Device Major Revision. First Bit.
5	ID_REV5	Device Major Revision. Second Bit.
6	ID_REV6	Device Major Revision. Third Bit.
7	ID_REV7	Device Major Revision. Fourth Bit.

APPLICATION CIRCUIT

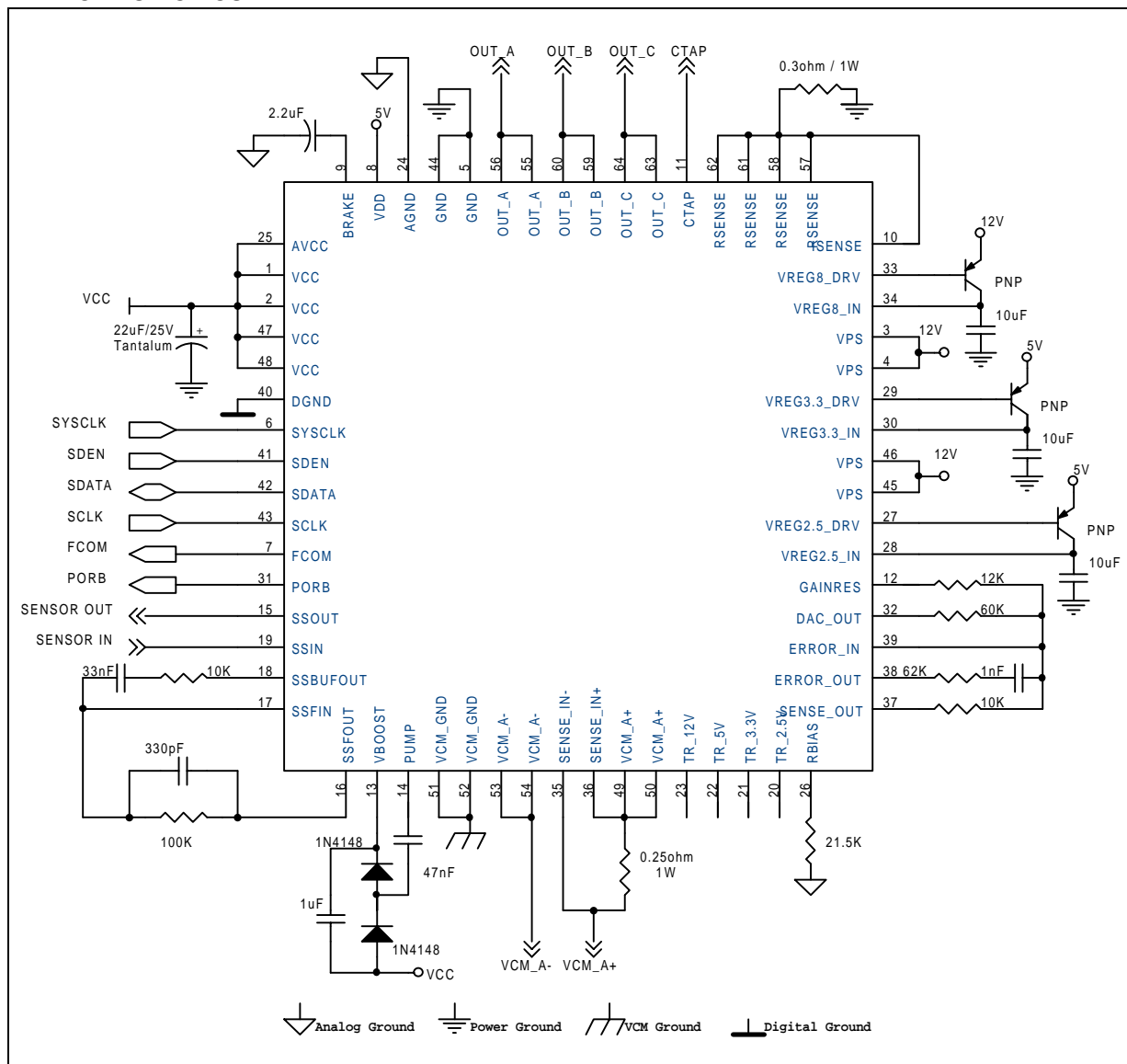

DIM.	mm			inch		
	MIN.	TYP.	MAX.	MIN.	TYP.	MAX.
A			1.60			0.063
A1	0.05		0.15	0.002		0.006
A2	1.35	1.40	1.45	0.053	0.055	0.057
B	0.18	0.23	0.28	0.007	0.009	0.011
C	0.12	0.16	0.20	0.0047	0.0063	0.0079
D		12.00			0.472	
D1		10.00			0.394	
D3		7.50			0.295	
e		0.50			0.0197	
E		12.00			0.472	
E1		10.00			0.394	
E3		7.50			0.295	
L	0.40	0.60	0.75	0.0157	0.0236	0.0295
L1		1.00			0.0393	
K	0°(min.), 7°(max.)					

OUTLINE AND MECHANICAL DATA

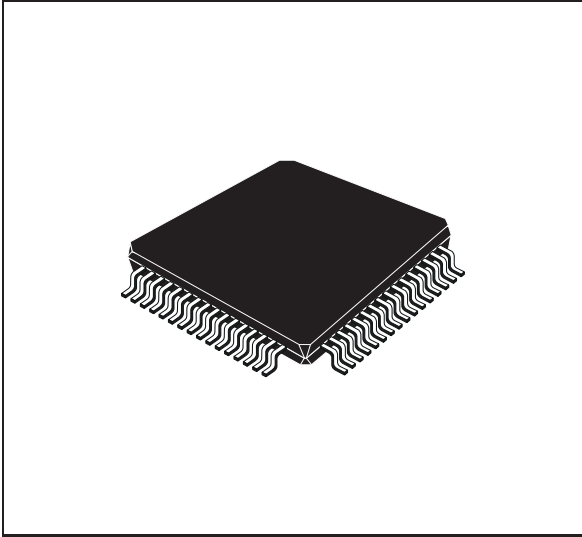

TQFP64

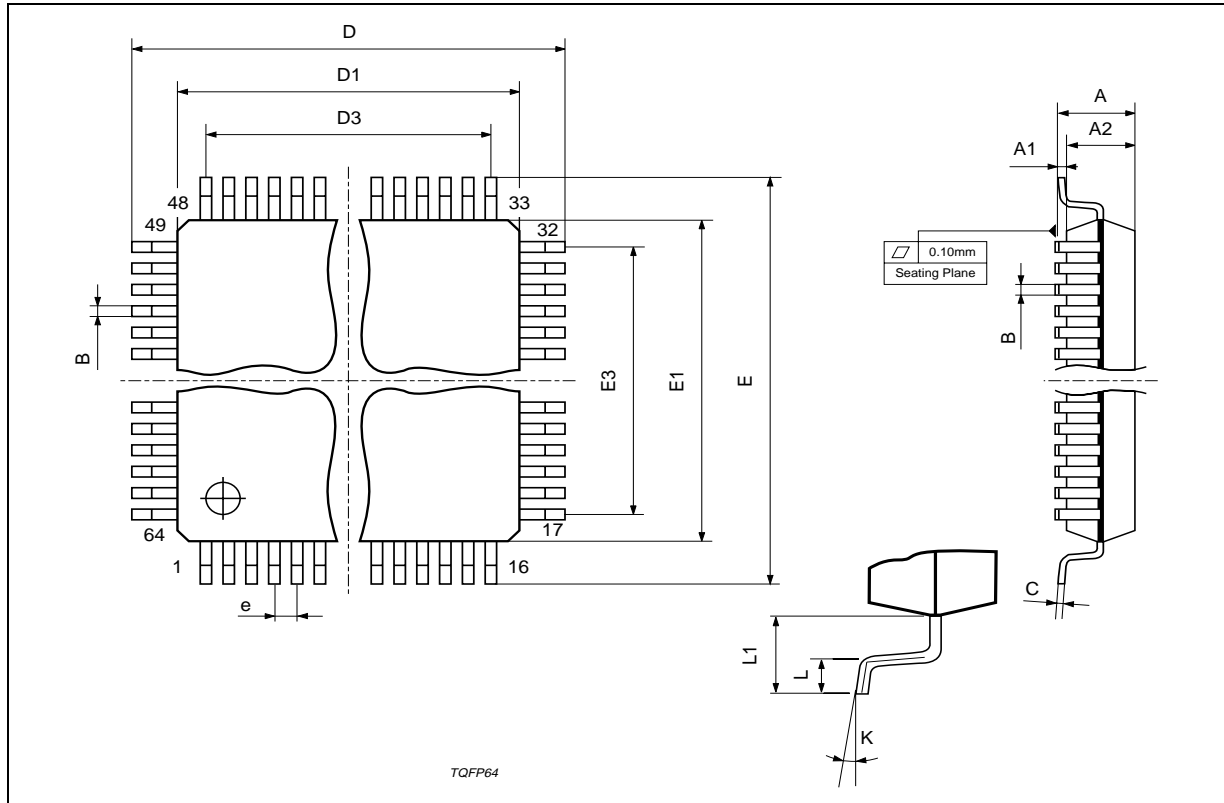

Information furnished is believed to be accurate and reliable. However, STMicroelectronics assumes no responsibility for the consequences of use of such information nor for any infringement of patents or other rights of third parties which may result from its use. No license is granted by implication or otherwise under any patent or patent rights of STMicroelectronics. Specifications mentioned in this publication are subject to change without notice. This publication supersedes and replaces all information previously supplied. STMicroelectronics products are not authorized for use as critical components in life support devices or systems without express written approval of STMicroelectronics.

The ST logo is a registered trademark of STMicroelectronics
© 1999 STMicroelectronics - All Rights Reserved

STMicroelectronics GROUP OF COMPANIES
Australia - Brazil - China - Finland - France - Germany - Hong Kong - India - Italy - Japan - Malaysia - Malta - Morocco - Singapore - Spain
- Sweden - Switzerland - United Kingdom - U.S.A.
<http://www.st.com>