



# THBT7011D

Application Specific Discretes  
A.S.D.<sup>TM</sup>

DUAL OVERVOLTAGE  
PROTECTION FOR TELECOM LINE

## FEATURES

- BIDIRECTIONAL CROWBAR PROTECTION.
- PEAK PULSE CURRENT :  
 $I_{PP} = 30A$  for 10/1000 $\mu s$  surge.
- HOLDING CURRENT :  
 $I_H = 150mA$ .
- BREAKDOWN VOLTAGE: 70V Min.
- LOW DYNAMIC BREAKOVER VOLTAGE.

## DESCRIPTION

Dedicated to telecommunication equipment protection, this device provides a dual bidirectional protection function.

Dynamic characteristics have been defined for several types of surges, in order to meet the SLIC maximum ratings.

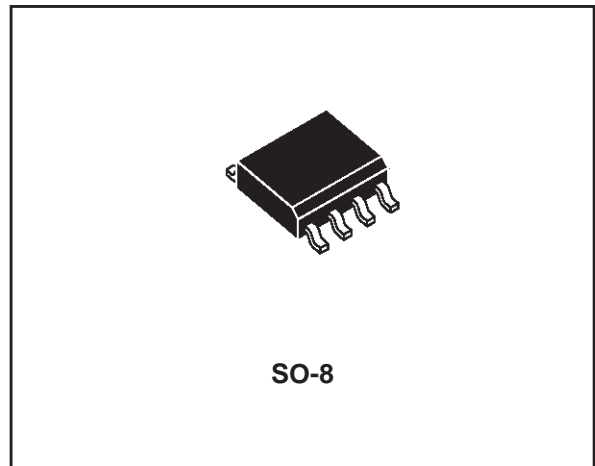

## FUNCTIONAL DIAGRAM

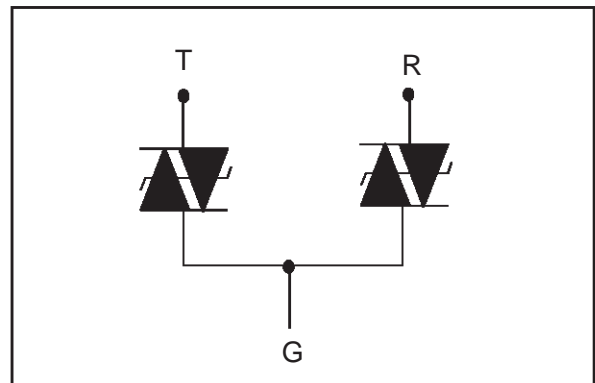

## PINOUT CONFIGURATION

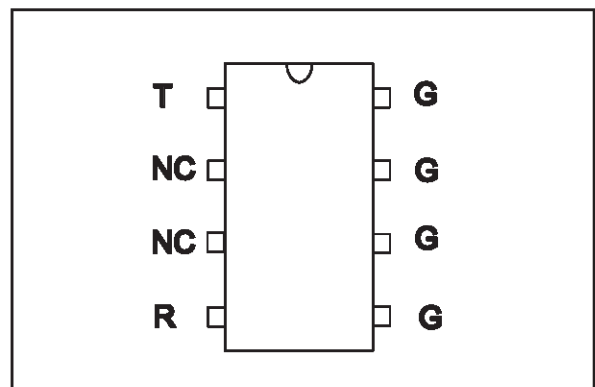

TM: ASD is trademarks of STMicroelectronics.

# THBT7011D

COMPLIES WITH THE FOLLOWING STANDARDS:	Peak Surge Voltage (V)	Voltage Waveform ( $\mu\text{s}$ )	Current Waveform ( $\mu\text{s}$ )	Admissible $I_{pp}$ (A)	Necessary Resistor ( $\Omega$ )
CCITT K20	4000	10/700	5/310	25	-
VDE0433	4000	10/700	5/310	40	10
VDE0878	4000	1.2/50	1/20	50	-
IEC-1000-4-5	level 4 level 4	10/700 1.2/50	5/310 8/20	25 50	- -
FCC Part 68, lightning surge type A	1500 800	10/160 10/560	10/160 10/560	47 35	25 15.5
FCC Part 68, lightning surge type B	100	9/720	5/320	25	-
BELLCORE TR-NWT-001089 First level	2500 1000	2/10 10/1000	2/10 10/1000	90 30	23 24
BELLCORE TR-NWT-001089 Second level	5000	2/10	2/10	90	50
CNET I31-24	4000	0.5/700	0.8/310	25	-

## ABSOLUTE MAXIMUM RATINGS ( $T_{amb} = 25^{\circ}\text{C}$ )

Symbol	Parameter	Value	Unit
$I_{PP}$	Peak pulse current (see note 1)	10/1000 $\mu\text{s}$	A
$I_{TSM}$	Non repetitive surge peak on-state current (F=50Hz)	$t_p = 100 \text{ ms}$ $t = 1 \text{ s}$	15.5 9 A
$T_{stg}$ $T_j$	Storage temperature range Maximum operating junction temperature	- 40 to + 150 + 150	$^{\circ}\text{C}$ $^{\circ}\text{C}$
$T_L$	Maximum lead temperature for soldering during 10s	260	$^{\circ}\text{C}$

Note 1 : Pulse waveform :

10/1000 $\mu\text{s}$   $t_r=10\mu\text{s}$   $t_p=1000\mu\text{s}$

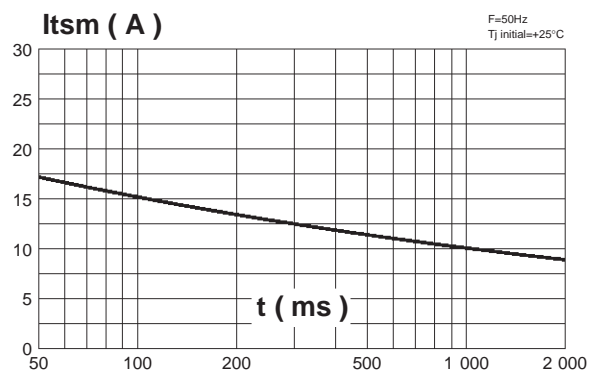
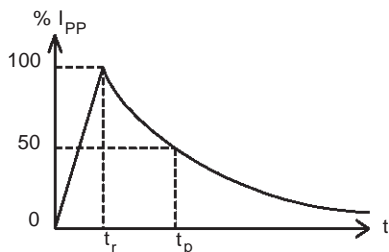

TEST CIRCUITS FOR  $I_{PP}$

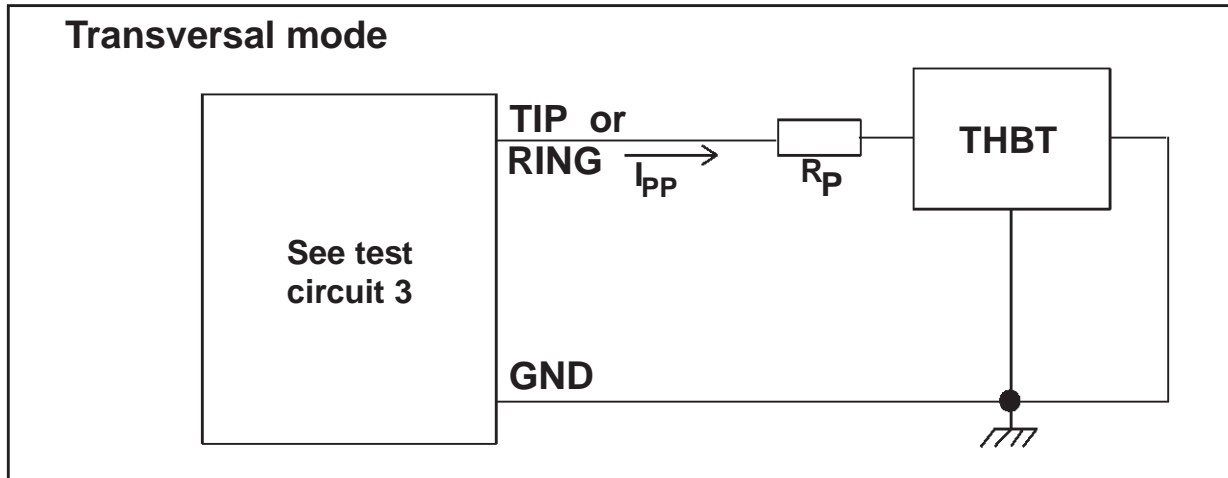

THERMAL RESISTANCES

Symbol	Parameter	Value	Unit
$R_{th(j-a)}$	Junction to ambient	170	$^{\circ}C/W$

ELECTRICAL CHARACTERISTICS ( $T_{amb} = 25^{\circ}C$ )

Symbol	Parameter
$V_{RM}$	Stand-off voltage
$I_{RM}$	Leakage current at stand-off voltage
$V_R$	Continuous Reverse voltage
$V_{BR}$	Breakdown voltage
$V_{BO}$	Breakover voltage
$I_H$	Holding current
$I_{BO}$	Breakover current
$I_{PP}$	Peak pulse current
C	Capacitance

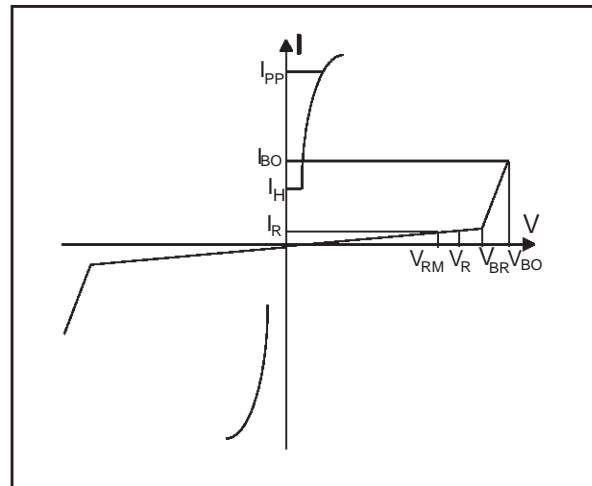

STATIC PARAMETERS BETWEEN TIP AND GND, RING AND GND

Type	$I_{RM} @ V_{RM}$		$I_R @ V_R$		$V_{BO} @ I_{BO}$			$I_H$	C
	max. $\mu A$	V	max. note 1 $\mu A$	V	max. note 2 V	min. mA	max. mA	min note 3 mA	max note 4 pF
THBT7011D	5	66	50	70	89	50	400	150	80

# THBT7011D

## STATIC PARAMETERS BETWEEN TIP AND RING

Type	$I_{RM}$ @ $V_{RM}$		$I_R$ @ $V_R$		C max note 4 pF
	max. $\mu A$	note 6 V	max. $\mu A$	note 6 V	
THBT7011D	5	132	50	140	40

Note 1:  $I_R$  measured at  $V_R$  guarantees  $V_{BR} > V_R$

Note 2: Measured at 50 Hz (1 cycle) test circuit 1.

Note 3: See the reference test circuit 2.

Note 4:  $V_R = 1V$ ,  $F = 1MHz$ .

Note 5: See test circuit 3 for  $V_{BO}$  dynamic parameters;  $R_p$  is the protection resistor located on the line card.

Note 6: Ground not connected or  $|V_{TIP}| = |V_{RING}|$  versus Ground

## DYNAMIC BREAKOVER VOLTAGES (Transversal mode)

Type	Symbol	Test conditions (see note 5)				Maximum	Unit
THBT7011D	$V_{BO}$	10/700 $\mu s$	1.5kV	$R_p=10\Omega$	$I_{PP}=30A$	90	V
		1.2/50 $\mu s$	1.5kV	$R_p=10\Omega$	$I_{PP}=30A$	95	
		2/10 $\mu s$	2.5kV	$R_p=62\Omega$	$I_{PP}=38A$	150	

## TEST CIRCUIT 1 for $I_{BO}$ and $V_{BO}$ parameters:

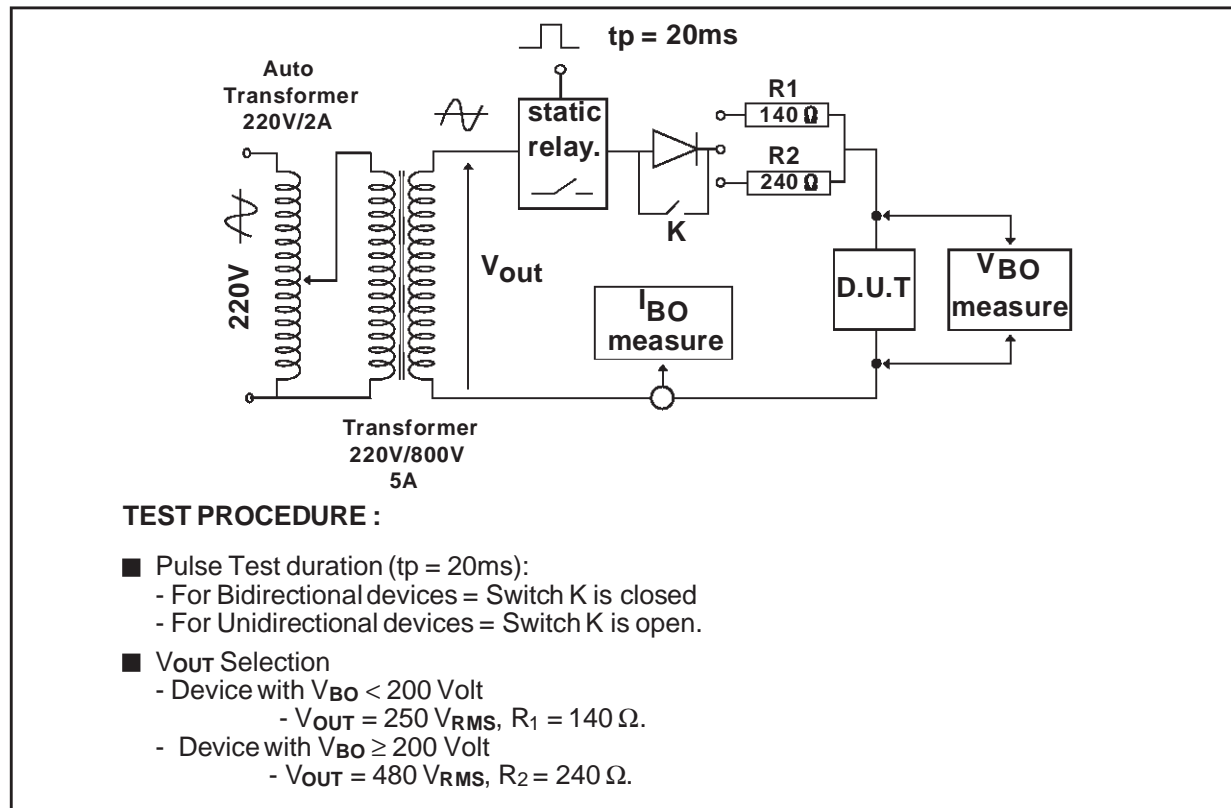

**TEST CIRCUIT 2 for  $I_H$  parameter.**

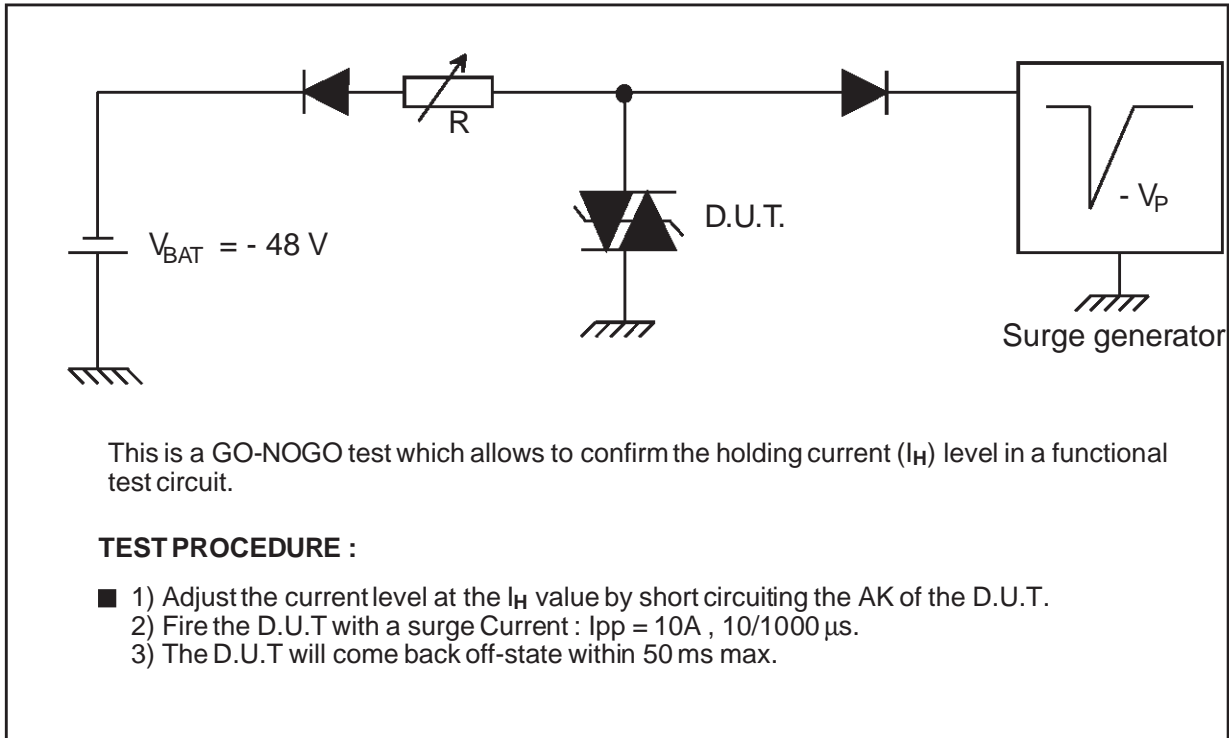

**TEST CIRCUIT 3 for  $I_{PP}$  and  $V_{BO}$  parameters :**

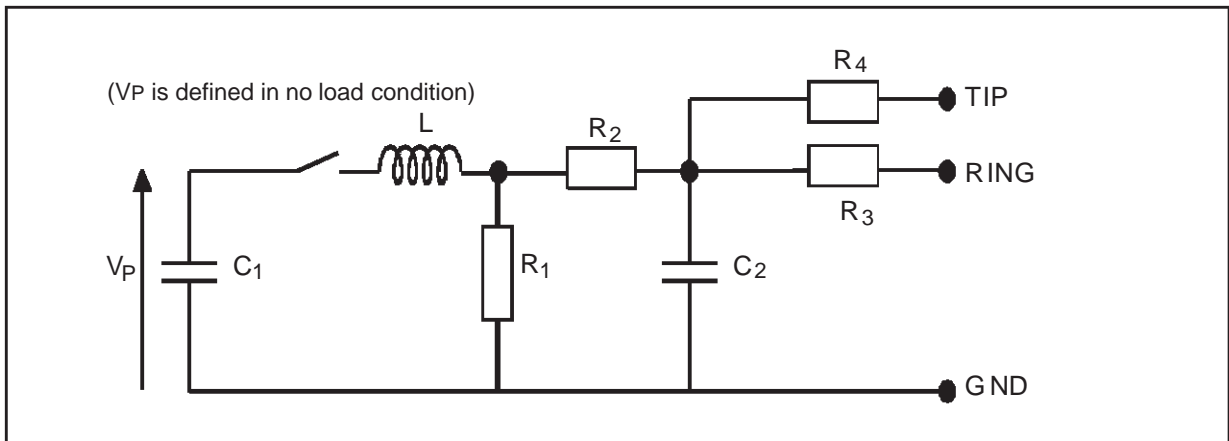

Pulse ( $\mu s$ )		$V_p$ (V)	$C_1$ ( $\mu F$ )	$C_2$ (nF)	$L$ ( $\mu H$ )	$R_1$ ( $\Omega$ )	$R_2$ ( $\Omega$ )	$R_3$ ( $\Omega$ )	$R_4$ ( $\Omega$ )	$I_{PP}$ (A)	$R_p$ ( $\Omega$ )
$t_r$	$t_p$										
10	700	1500	20	200	0	50	15	25	25	30	10
1.2	50	1500	1	33	0	76	13	25	25	30	10
2	10	2500	10	0	1.1	1.3	0	3	3	38	62

**THBT7011D**

**APPLICATION CIRCUIT :**

**1 - Line card protection**

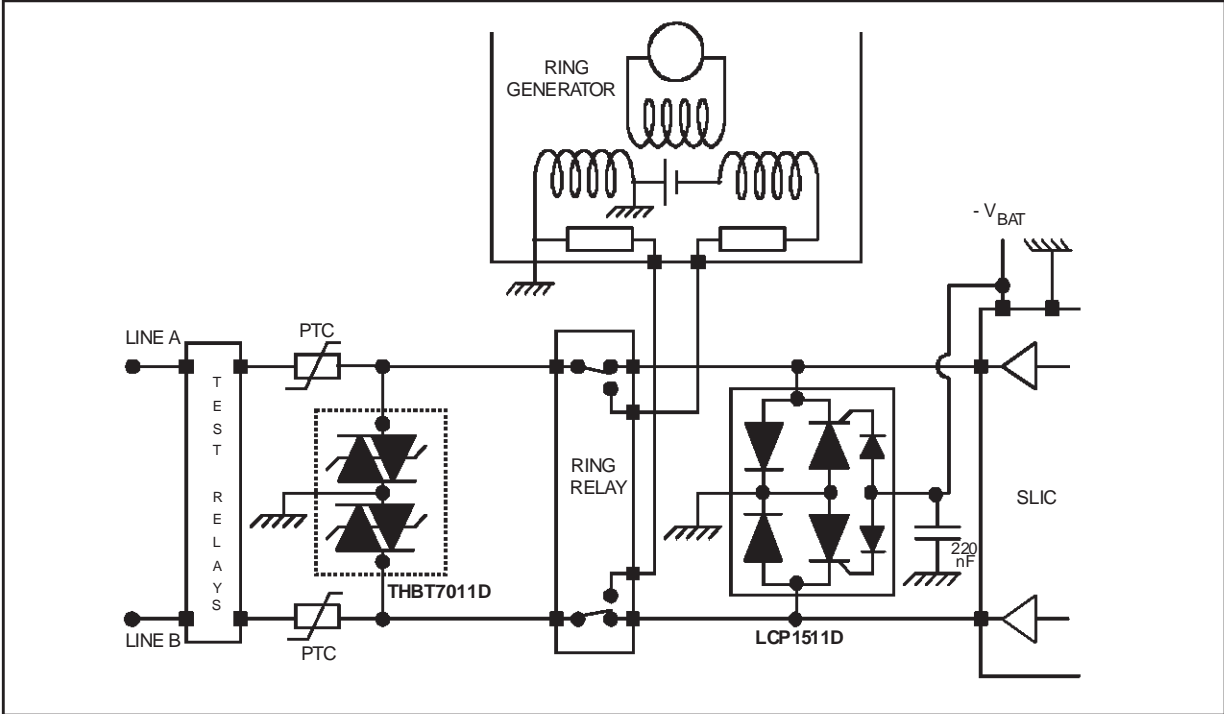

ORDER CODE

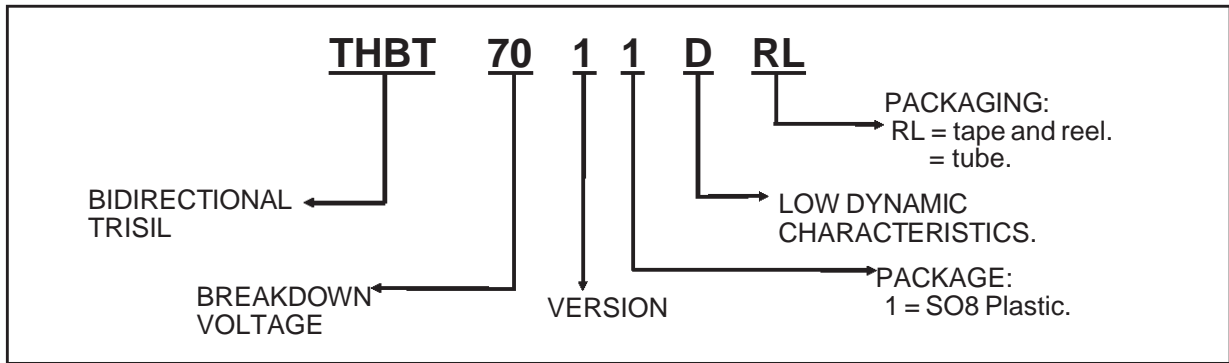

MARKING

Types	Package	Marking
THBT7011D	SO-8	BT701D

PACKAGE MECHANICAL DATA.  
SO-8 Plastic

MARKING : Logo, Date Code, Part Number.

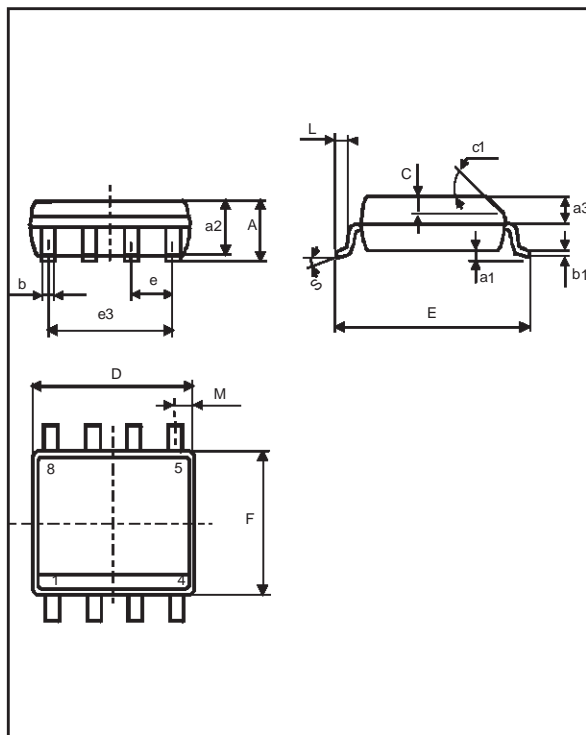

**Packaging :** Products supplied in antistatic tubes or tape and reel.

**Weight :** 0.08g



REF.	DIMENSIONS					
	Millimetres			Inches		
	Min.	Typ.	Max.	Min.	Typ.	Max.
A			1.75			0.069
a1	0.1		0.25	0.004		0.010
a2			1.65			0.065
a3	0.65		0.85	0.025		0.033
b	0.35		0.48	0.014		0.019
b1	0.19		0.25	0.007		0.010
C	0.25	0.50	0.50	0.010		0.020
c1	45° (typ)					
D	4.8		5.0	0.189		0.197
E	5.8		6.2	0.228		0.244
e		1.27			0.050	
e3		3.81			0.150	
F	3.8		4.0	0.15		0.157
L	0.4		1.27	0.016		0.050
M			0.6			0.024
S	8° (max)					

Information furnished is believed to be accurate and reliable. However, STMicroelectronics assumes no responsibility for the consequences of use of such information nor for any infringement of patents or other rights of third parties which may result from its use. No license is granted by implication or otherwise under any patent or patent rights of STMicroelectronics. Specifications mentioned in this publication are subject to change without notice. This publication supersedes and replaces all information previously supplied. STMicroelectronics products are not authorized for use as critical components in life support devices or systems without express written approval of STMicroelectronics.

The ST logo is a registered trademark of STMicroelectronics

© 1998 STMicroelectronics - Printed in Italy - All rights reserved.

STMicroelectronics GROUP OF COMPANIES

Australia - Brazil - Canada - China - France - Germany - Italy - Japan - Korea - Malaysia - Malta - Mexico - Morocco -  
The Netherlands - Singapore - Spain - Sweden - Switzerland - Taiwan - Thailand - United Kingdom - U.S.A.

<http://www.st.com>