

**ST63140, ST63146
ST63126, ST63156**

DATA SHEET

1st Edition

OCTOBER 1993

USE IN LIFE SUPPORT DEVICES OR SYSTEMS MUST BE EXPRESSLY AUTHORIZED.

SGS-THOMSON PRODUCTS ARE NOT AUTHORIZED FOR USE AS CRITICAL COMPONENTS IN LIFE SUPPORT DEVICES OR SYSTEMS WITHOUT THE EXPRESS WRITTEN APPROVAL OF SGS-THOMSON Microelectronics.

As used herein :

1. Life support devices or systems are those which (a) are intended for surgical implant into the body, or (b) support or sustain life, and whose failure to perform, when properly used in accordance with instructions for use provided with the product, can be reasonably expected to result in significant injury to the user.
2. A critical component is any component of a life support device or system whose failure to perform can reasonably be expected to cause the failure of the life support device or system, or to affect its safety or effectiveness.

ST631xx DATASHEET INDEX

	Pages
ST63140, ST63142 ST63126, ST63156	1
GENERAL DESCRIPTION	3
PIN DESCRIPTION	5
ST631xx CORE	7
MEMORY SPACES	10
STACK SPACE	16
INTERRUPT	16
RESET	20
WAIT & STOP MODES	22
ON-CHIP CLOCK OSCILLATOR	23
INPUT/OUTPUT PORTS	24
TIMERS	27
HARDWARE ACTIVATED DIGITAL WATCHDOG FUNCTION	30
SERIAL PERIPHERAL INTERFACE	31
14-BIT VOLTAGE SYNTHESIS TUNING PERIPHERAL	40
6-BIT PWM D/A CONVERTER AND 62.5 kHz OUTPUT FUNCTION	41
AFC A/D INPUT, KEYBOARD INPUTS AND BANDSWITH OUTPUTS	43
INFRARED INPUT (IRIN)	44
ON-SCREEN DISPLAY (OSD)	45
SOFTWARE DESCRIPTION	54
ABSOLUTE MAXIMUM RATINGS	59
EEPROM INFORMATION	60
PACKAGE MECHANICAL DATA	63
ORDERING INFORMATION TABLE	65
ST63E140/T140, E142/T142 ST63E126/T126, E156/T156	67
GENERAL DESCRIPTION	69
PIN DESCRIPTION	71
EPROM/OTP DESCRIPTION	74
ABSOLUTE MAXIMUM RATINGS	75
EEPROM INFORMATION	76
PACKAGE MECHANICAL DATA	79
ORDERING INFORMATION TABLE	82

**8-BIT HCMOS MCUs FOR
TV FREQUENCY & VOLTAGE SYNTHESIS WITH OSD**

PRELIMINARY DATA

- 4.5 to 6V operating Range
- 8MHz Maximum Clock Frequency
- User Program ROM: 7948 bytes
- Reserved Test ROM: 244 bytes
- Data ROM: user selectable size
- Data RAM: 256 bytes
- Data EEPROM: 128 bytes
- 40-Pin Dual in Line Plastic Package for the ST63126, 156
- 28-Pin Dual in Line Plastic Package for the ST63140, 142
- Up to 18 software programmable general purpose Inputs/Outputs, including 8 direct LED driving Outputs
- 3 Inputs for keyboard scan (KBY0-2)
- Up to 4 high voltage outputs (BSW0-3)
- Two Timers each including an 8-bit counter with a 7-bit programmable prescaler
- Digital Watchdog Function
- Serial Peripheral Interface (SPI) supporting S-BUS/I²C BUS and standard serial protocols
- Up to Four 6-bit PWM D/A Converters
- 62.5kHz Output pin
- 14 bit counter for voltage synthesis tuning (ST63156, ST63140)
- AFC A/D converter with 0.5V resolution
- Four interrupt vectors (IRIN/NMI, Timer 1 & 2, VSYNC.)
- On-chip clock oscillator
- 5 Lines by 15 Characters On-Screen Display Generator with 128 Characters (2 banks)
- All ROM types are supported by pin-to-pin EPROM and OTP versions.
- The development tool of the ST631xx microcontrollers consists of the ST63TVS-EMU emulation and development system to be connected via a standard RS232 serial line to an MS-DOS Personal Computer.

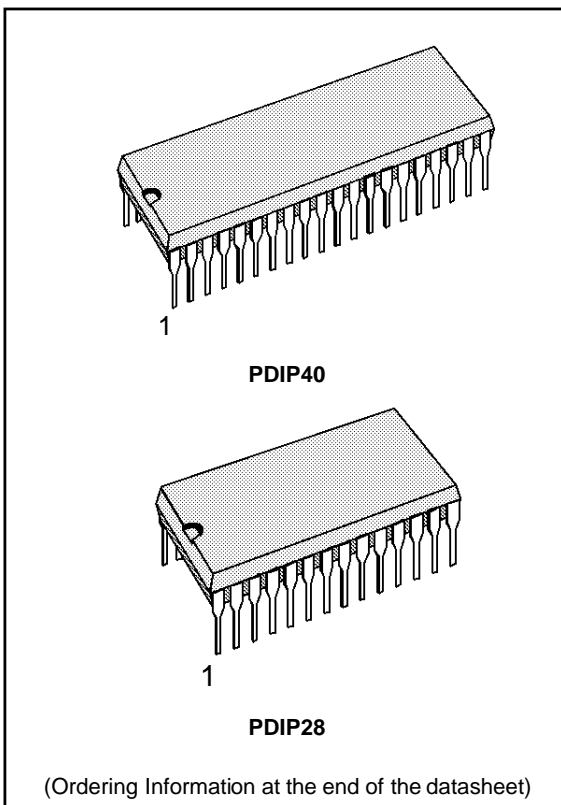

DEVICE SUMMARY

DEVICE	ROM (Bytes)	TUN.	I/O Pins	Package
ST63126	8K	FS	12	PDIP40
ST63156	8K	VS	11	PDIP40
ST63140	8K	VS	6	PDIP28
ST63142	8K	FS	6	PDIP28

Figure 1. ST63126, 156 Pin Configuration

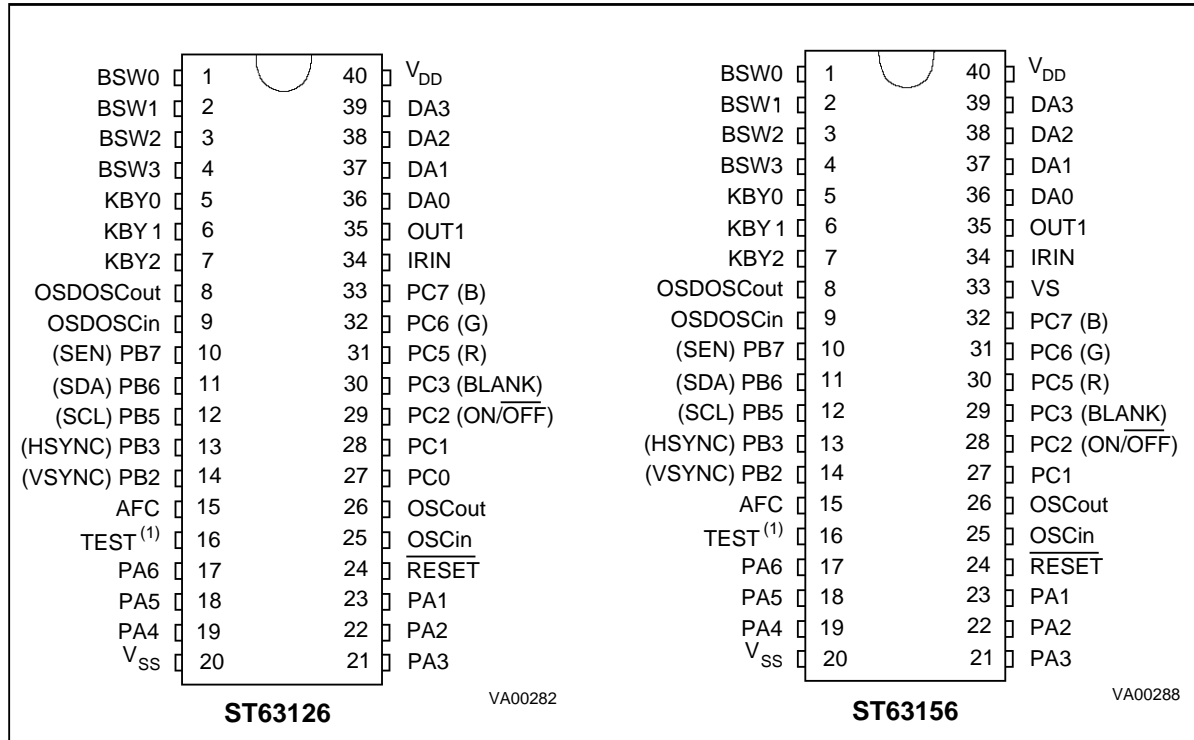

Note 1. This pin is also the VPP input for EPROM based devices

Figure 2. ST63140, 142 Pin Configuration

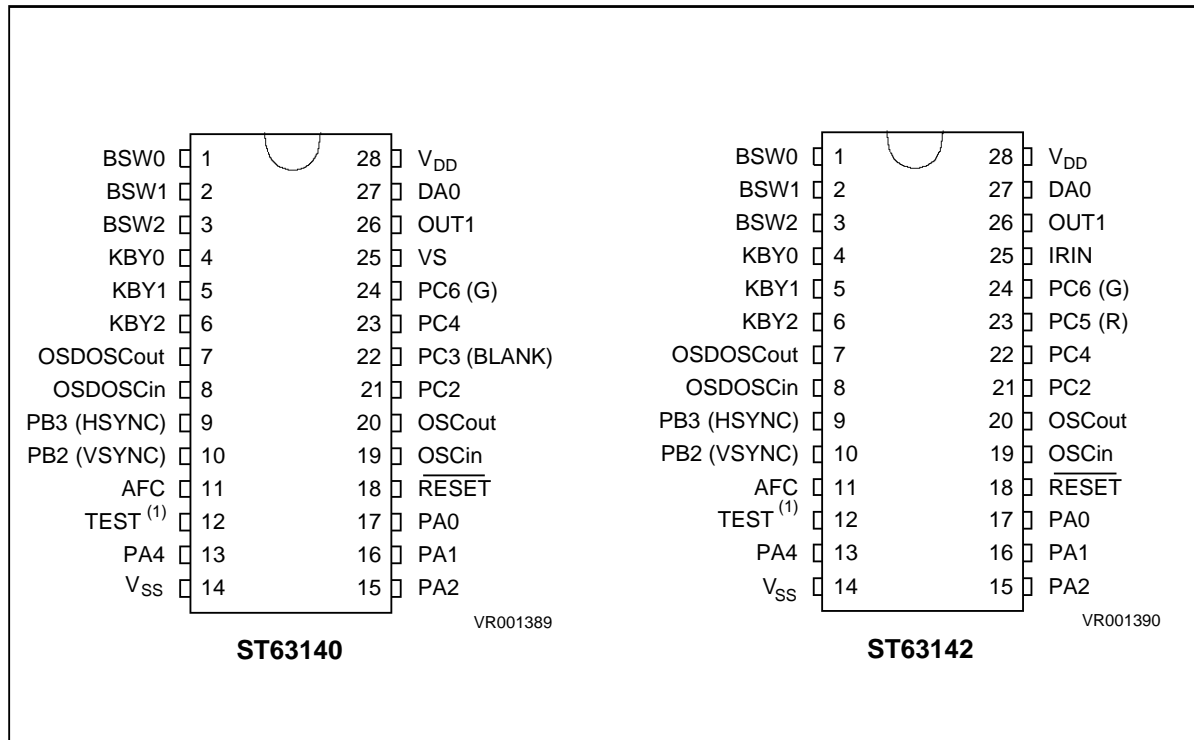

Note 1. This pin is also the VPP input for EPROM based devices

GENERAL DESCRIPTION

The ST63140, 142, 126, 156 microcontrollers are members of the 8-bit HCMOS ST631xx family, a series of devices specially oriented to TV applications. Different ROM size and peripheral configurations are available to give the maximum application and cost flexibility. All ST631xx members are based on a building block approach: a common core is surrounded by a combination of on-chip peripherals (macrocells) available from a standard library. These peripherals are designed with the same Core technology providing full compatibility and short design time. Many of these macrocells are specially dedicated to TV applications. The macrocells of the ST631xx family are: two Timer peripherals each including an 8-bit counter with a

7-bit software programmable prescaler (Timer), a digital hardware activated watchdog function (DHWD), a 14-bit voltage synthesis tuning peripheral, a Serial Peripheral Interface (SPI), up to four 6-bit PWM D/A converters, an AFC A/D converter with 0.5V resolution, an on-screen display (OSD) with 15 characters per line and 128 characters (in two banks each of 64 characters). In addition the following memory resources are available: program ROM (7K), data RAM (256 bytes), EEPROM (128 bytes).

Refer to pin configuration figures and to ST631xx device summary (Table 1) for the definition of ST631xx family members and a summary of differences among the different types.

Figure 3. ST631xx Block Diagram

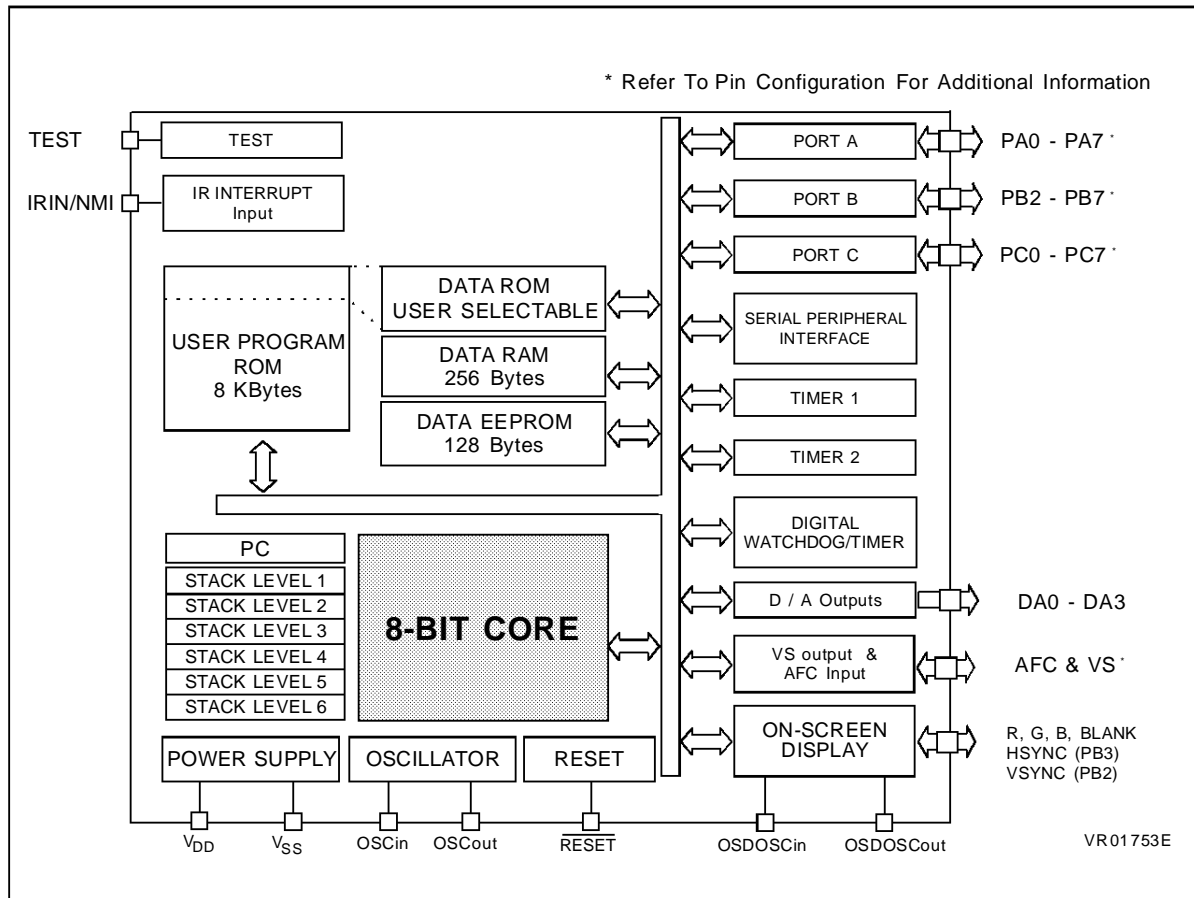

Table 1. Device Summary

DEVICE	ROM (Bytes)	RAM (Bytes)	EEPROM (Bytes)	I/O	KBY I/O	BSW OUT	AFC	VS	D/A	PACK.	EMUL. DEVICES
ST63126	8K	256	128	12	3	4	YES	NO	4	PDIP40	ST63E126
ST63156	8K	256	128	11	3	4	YES	YES	4	PDIP40	ST63E156
ST63140	8K	256	128	6	3	3	YES	YES	1	PDIP28	ST6E140
ST63142	8K	256	128	6	3	3	YES	NO	1	PDIP28	ST63E142

PIN DESCRIPTION

V_{DD} and V_{SS}. Power is supplied to the MCU using these two pins. V_{DD} is power and V_{SS} is the ground connection.

OSCin, OSCout. These pins are internally connected to the on-chip oscillator circuit. A quartz crystal or a ceramic resonator can be connected between these two pins in order to allow the correct operation of the MCU with various stability/cost trade-offs. The OSCin pin is the input pin, the OSCout pin is the output pin.

RESET. The active low **RESET** pin is used to start the microcontroller to the beginning of its program.

TEST. The TEST pin must be held at V_{SS} for normal operation.

PA0-PA7. These 8 lines are organized as one I/O port (A). Each line may be configured as either an input or as an output under software control of the data direction register. Port A has an open-drain (12V drive) output configuration with direct LED driving capability (30mA, 1V).

PB2-PB3, PB5-PB7. These lines are organized as one I/O port (B). Each line may be configured as either an input with or without internal pull-up resistor or as an output under software control of the data direction register. PB2-PB3 have a push-pull configuration in output mode while PB5-PB7 are open-drain (5V drive).

PB2 and PB3 lines are connected to the VSYNC and HSYNC control signals of the OSD cell; to provide the right signals to the OSD these I/O lines should be programmed in input mode and the user can read "on the fly" the state of VSYNC and HSYNC signals. PB2 is also connected with the VSYNC Interrupt. The active polarity of VSYNC Interrupt signal is software controlled. The active polarity of these synchronization input pins to the OSD macrocell can be selected by the user as ROM mask option. If the device is specified to have negative logic inputs, then when these signals are low the OSD oscillator stops. If the device is specified to have positive logic inputs, then when these signals are high the OSD oscillator stops.

PB5, PB6 and PB7 lines, when in output modes, are "ANDed" with the SPI control signals. PB5 is connected with the SPI clock signal (SCL), PB6 with the SPI data signal (SDA) while PB7 is connected with SPI enable signal (SEN).

PC0-PC7. These 8 lines are organized as one I/O port (C). Each line may be configured as either an input with or without internal pull-up resistor or as an output under software control of the data direction register. PC0-PC2, PC4 have a push-pull configuration in output mode while PC3, PC5-PC7 (OSD signals) are open-drain (5V drive). PC3, PC5, PC6 and PC7 lines when in output mode are "ANDed" with the character and blank signals of the OSD cell. PC3 is connected with the OSD BLANK signal, PC5, PC6 and PC7 with the OSD R, G and B signals. The active polarity of these signals can be selected by the user as ROM mask option. PC2 is also used as TV set ON-OFF switch (5V drive).

DA0-DA3. These pins are the four PWM D/A outputs (with 32kHz repetition) of the 6-bit on-chip D/A converters. The PWM function can be disabled by software and these lines can be used as general purpose open-drain outputs (12V drive).

IRIN. This pin is the external NMI of the MCU.

OUT1. This pin is the 62.5kHz output specially suited to drive multi-standard chroma processors. This function can be disabled by software and the pin can be used as general purpose open-drain output (12V drive).

BSW0-BSW3. These output pins can be used to select up to 4 tuning bands. These lines are configured as open-drain outputs (12V drive).

KBY0-KBY2. These pins are input only and can be used for keyboard scan. They have CMOS threshold levels with Schmitt Trigger and on-chip 100kΩ pull-up resistors.

AFC. This is the input of the on-chip 10 level comparator that can be used to implement the AFC function. This pin is an high impedance input able to withstand signals with a peak amplitude up to 12V.

OSDOSCin, OSDOSCout. These are the On Screen Display oscillator terminals. An oscillation capacitor and coil network have to be connected to provide the right signal to the OSD.

VS. This is the output pin of the on-chip 14-bit voltage synthesis tuning cell (VS). The tuning signal present at this pin gives an approximate resolution of 40kHz per step over the UHF band. This line is a push-pull output with standard drive (ST63140, ST63156 only).

Table 2. Pin Summary

Pin Function	Description
DA0 to DA3	Output, Open-Drain, 12V
BSW0 to BSW3	Output, Open-Drain, 12V
IRIN	Input, Resistive Bias, Schmitt Trigger
AFC	Input, High Impedance, 12V
OUT1	Output, Open-Drain, 12V
KBY0 to KBY2	Input, Pull-up, Schmitt Trigger
R,G,B, BLANK	Output, Open-Drain, 5V
HSYNC, VSYNC	Input, Pull-up, Schmitt Trigger
OSDOSCin	Input, High Impedance
OSDOSCout	Output, Push-Pull
TEST	Input, Pull-Down
OSCin	Input, Resistive Bias, Schmitt Trigger to Reset Logic Only
OSCCout	Output, Push-Pull
RESET	Input, Pull-up, Schmitt Trigger Input
VS	Output, Push-Pull
PA0-PA6	I/O, Open-Drain, 12V, No Input Pull-up, Schmitt Trigger, High Drive
PB2-PB3, PB5-PB7	I/O, Push-Pull, 5V, Input Pull-up, Schmitt Trigger
PB5-PB7	I/O, Open-Drain, 5V, Input Pull-up, Schmitt Trigger
PC0-PC2, PC4	I/O, Push-Pull, 5V, Input Pull-up, Schmitt Trigger
PC3, PC5-PC7	I/O, Open-Drain, 5V, Input Pull-up, Schmitt Trigger
V _{DD} , V _{SS}	Power Supply Pins

ST631xx CORE

The Core of the ST631xx Family is implemented independently from the I/O or memory configuration. Consequently, it can be treated as an independent central processor communicating with I/O and memory via internal addresses, data, and control busses. The in-core communication is arranged as shown in the following block diagram figure; the controller being externally linked to both the reset and the oscillator, while the core is linked to the dedicated on-chip macrocells peripherals via the serial data bus and indirectly for interrupt purposes through the control registers.

Registers

The ST631xx Family Core has six registers and three pairs of flags available to the programmer. They are shown in Figure 5 and are explained in the following paragraphs together with the program and data memory page registers.

Accumulator (A). The accumulator is an 8-bit general purpose register used in all arithmetic calculations, logical operations, and data manipulations. The accumulator is addressed in the data space as RAM location at address FFh . Accordingly, the ST631xx instruction set can use the accumulator as any other register of the data space.

Figure 5. ST631xx Core Programming Model

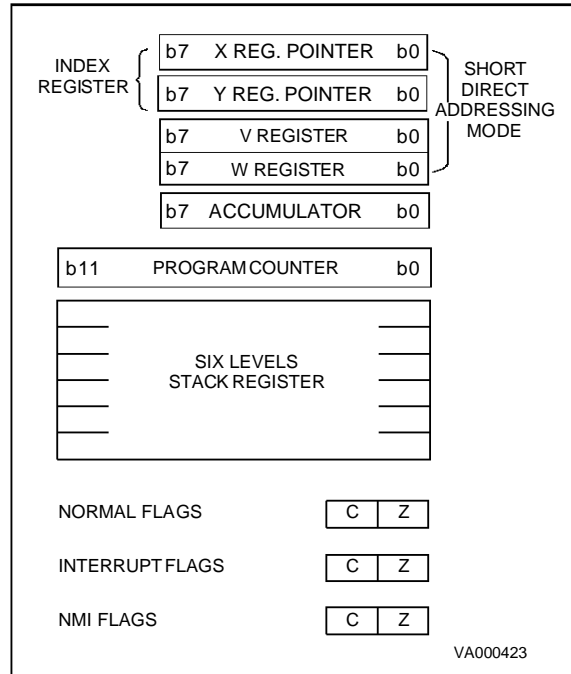
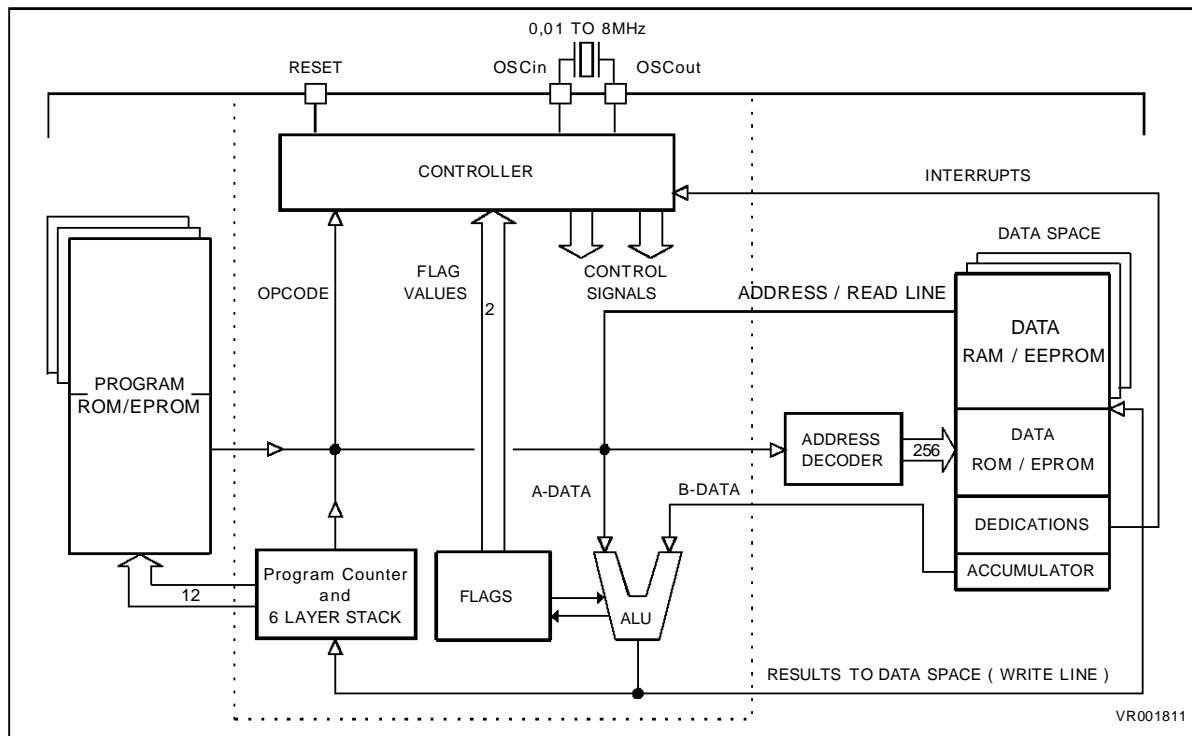

Figure 4. ST631xx Core Block Diagram



ST631xx CORE (Continued)

Indirect Registers (X, Y). These two indirect registers are used as pointers to the memory locations in the data space. They are used in the register-indirect addressing mode. These registers can be addressed in the data space as RAM locations at the 80h (X) and 81h (Y) addresses. They can also be accessed with the direct, short direct, or bit direct addressing modes. Accordingly, the ST631xx instruction set can use the indirect registers as any other register of the data space.

Short Direct Registers (V, W). These two registers are used to save one byte in short direct addressing mode. These registers can be addressed in the data space as RAM locations at the 82h (V) and 83h (W) addresses. They can also be accessed with the direct and bit direct addressing modes. Accordingly, the ST631xx instruction set can use the short direct registers as any other register of the data space.

Program Counter (PC)

The program counter is a 12-bit register that contains the address of the next ROM location to be processed by the core. This ROM location may be an opcode, an operand, or an address of operand. The 12-bit length allows the direct addressing of 4096 bytes in the program space. Nevertheless, if the program space contains more than 4096 locations, the further program space can be addressed by using the Program ROM Page Register. The PC value is incremented, after it is read for the address of the current instruction, by sending it through the ALU, so giving the address of the next byte in the program. To execute relative jumps the PC and the offset values are shifted through the ALU, where they will be added, and the result is shifted back into the PC. The program counter can be changed in the following ways:

- JP (Jump) instruction.... PC = Jump address
- CALL instruction PC = Call address
- Relative Branch instructions PC = PC + offset
- Interrupt PC = Interrupt vector
- Reset PC = Reset vector
- RET & RETI instructions PC = Pop (stack)
- Normal instruction PC = PC + 1

Flags (C, Z)

The ST631xx Core includes three pairs of flags that correspond to 3 different modes: normal mode, interrupt mode and Non-Maskable-Interrupt-Mode. Each pair consists of a CARRY flag and a ZERO flag. One pair (CN, ZN) is used during normal operation, one pair is used during the interrupt mode (CI, ZI) and one is used during the not-maskable interrupt mode (CNMI, ZNMI).

The ST631xx Core uses the pair of flags that corresponds to the actual mode: as soon as an interrupt (resp. a Non-Maskable-Interrupt) is generated, the ST631xx Core uses the interrupt flags (resp. the NMI flags) instead of the normal flags. When the RETI instruction is executed, the normal flags (resp. the interrupt flags) are restored if the MCU was in the normal mode (resp. in the interrupt mode) before the interrupt. Should be observed that each flag set can only be addressed in its own routine (Not-maskable interrupt, normal interrupt or main routine). The interrupt flags are not cleared during the context switching and so, they remain in the state they were at the exit of the last routine switching.

The Carry flag is set when a carry or a borrow occurs during arithmetic operations, otherwise it is cleared. The Carry flag is also set to the value of the bit tested in a bit test instruction, and participates in the rotate left instruction.

The Zero flag is set if the result of the last arithmetic or logical operation was equal to zero, otherwise it is cleared.

The switching between these three sets is automatically performed when an NMI, an interrupt and a RETI instructions occur. As the NMI mode is automatically selected after the reset of the MCU, the ST631xx Core uses at first the NMI flags.

ST631xxx CORE (Continued)

Stack

The ST631xx Core includes true LIFO hardware stack that eliminates the need for a stack pointer. The stack consists of six separate 12-bit RAM locations that do not belong to the data space RAM area. When a subroutine call (or interrupt request) occurs, the contents of each level is shifted into the next level while the content of the PC is shifted into the first level (the value of the sixth level will be lost). When subroutine or interrupt return occurs (RET or RETI instructions), the first level register is shifted back into the PC and the value of each level is shifted back into the previous level. These two operating modes are described in Figure 6. Since the accumulator, as all other data space registers, is not stored in this stack the handling of this registers shall be performed inside the subroutine. The stack pointer will remain in its deepest position, if more than 6 calls or interrupts are executed, so that the last return address will be lost. It will also remain in its highest position if the stack is empty and a RET or RETI is executed. In this case the next instruction will be executed.

Figure 6. Stack Operation

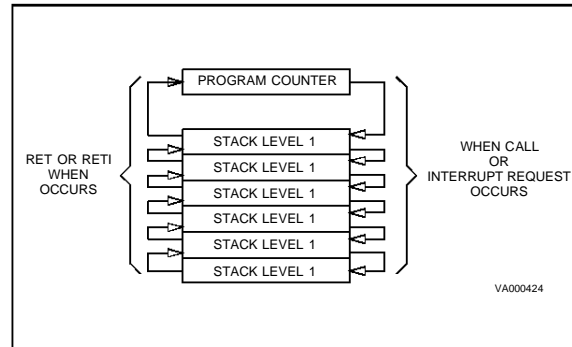

MEMORY SPACES

The MCUs operate in three different memory spaces: Program Space, Data Space, and Stack Space. A description of these spaces is shown in the following Figures.

Program Space

The program space is physically implemented in the ROM and includes all the instructions that are to be executed, as well as the data required for the immediate addressing mode instructions, the reserved test area and user vectors. It is addressed thanks to the 12-bit Program Counter register (PC register) and so, the ST631xx Core can directly address up to 4K bytes of Program Space. Nevertheless, the Program Space can be extended by the addition of 2-Kbyte ROM banks as it is shown in Figure 8 in which the 8K bytes memory is described.

These banks are addressed by pointing to the 000h-7FFh locations of the Program Space thanks to the Program Counter, and by writing the appropriate code in the Program ROM Page Register (PRPR) located at address CAh of the Data Space. Because interrupts and common subroutines should be available all the time only the lower 2K bytes of the 4K program space are bank switched while the upper 2K bytes can be seen as

static space. Table 3 gives the codes that allow the selection of the corresponding banks.

Note that, from the memory point of view, the Page 1 and the Static Page represent the same physical memory: it is only a different way of addressing the same location. On the ST631xx a total of 8192 bytes of ROM have been implemented; 7948 are available as user ROM while 244 are reserved for testing.

Figure 8. ST631xx 8K Bytes Program Space Addressing Description

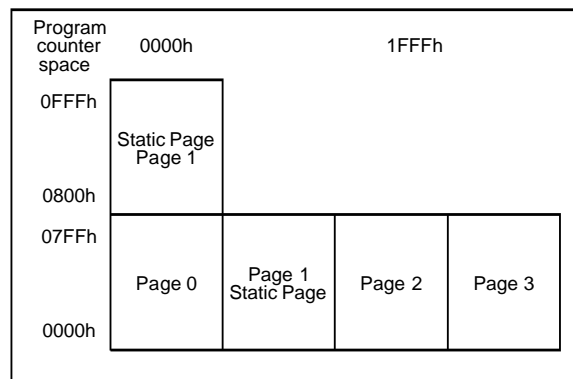
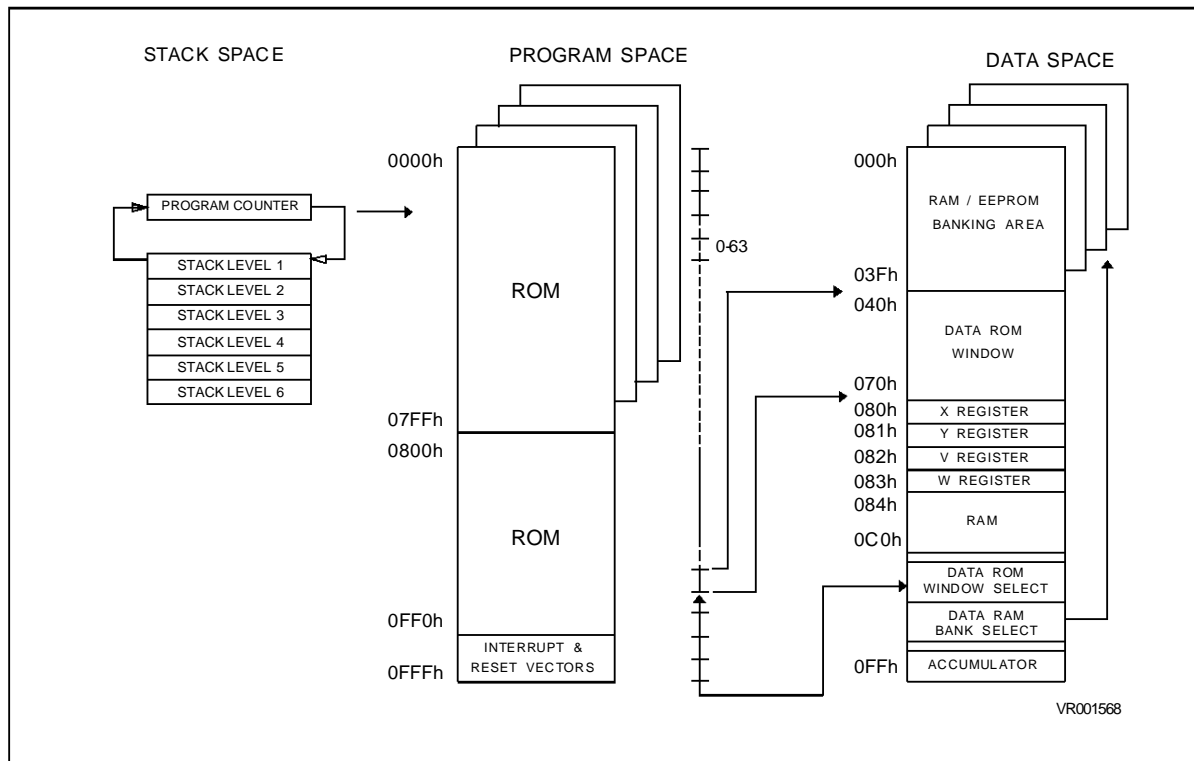
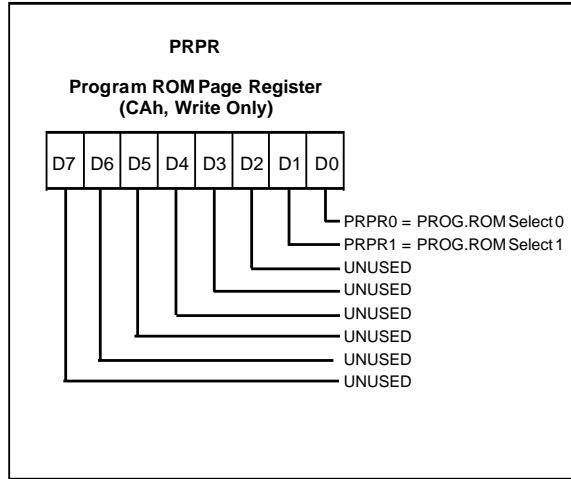

Figure 7. ST631xx Memory Addressing Description Diagram



MEMORY SPACES (Continued)

Figure 11. Program ROM Page Register



D7-D2. These bits are not used.

PRPR1-PRPR0. These are the program ROM banking bits and the value loaded selects the corresponding page to be addressed in the lower part of 4K program address space as specified in Table 3. This register is undefined on reset.

Note:

Only the lower part of address space has been bankswitched because interrupt vectors and common subroutines should be available all the time. The reason of this structure is due to the fact that it is not possible to jump from a dynamic page to another, unless jumping back to the static page, changing contents of PRPR, and, then, jumping to a different dynamic page.

Care is required when handling the PRPR as it is write only. For this reason, it is not allowed to change the PRPR contents while executing interrupts drivers, as the driver cannot save and then restore its previous content. Anyway, this operation may be necessary if the sum of common routines and interrupt drivers will take more than 2K bytes; in this case could be necessary to divide the interrupt driver in a (minor) part in the static page (start and end), and in the second (major) part in one dynamic page. If it is impossible to avoid the writing of this register in interrupts drivers, an image of this register must be saved in a RAM location, and each time the program writes the PRPR it writes also the image register. The image register must be written first, so if an interrupt occurs between the two instructions the PRPR is not affected.

Table 3. Program ROM Page Register Coding

PRPR1	PRPR0	PC11	Memory Page
X	X	1	Static Page (Page1)
0	0	0	Page 0
0	1	0	Page 1 (Static Page)
1	0	0	Page 2
1	1	0	Page 3

This register is undefined on reset. Neither read nor single bit instructions may be used to address this register.

Table 4. ST631xx Program ROM Map

ROM Page	Device Address	Device Address ⁽¹⁾	Description
PAGE 0	0000h-007Fh 0080h-07FFh	0000h-007Fh 0080h-07FFh	Reserved User ROM
PAGE 1 "STATIC"	0800h-0F9Fh 0FA0h-0FEFh 0FF0h-0FF7h 0FF8h-0FFBh 0FFCh-0FFDh 0FFEh-0FFFh	0800h-0F9Fh 0FA0h-0FEFh 0FF0h-0FF7h 0FF8h-0FFBh 0FFCh-0FFDh 0FFEh-0FFFh	User ROM Reserved Interrupt Vectors Reserved NMI Vector Reset Vector
PAGE 2	0000h-000Fh 0010h-07FFh	1000h-100Fh 1010h-17FFh	Reserved User ROM
PAGE 3	0000h-000Fh 0010h-07FFh	1800h-180Fh 1810h-1FFFh	Reserved User ROM

Note 1. EPROM addresses relate to the use of ST63E1xx EPROM Emulation device.

MEMORY SPACES (Continued)

Data Space

The instruction set of the ST631xx Core operates on a specific space, named Data Space that contains all the data necessary for the processing of the program. The Data Space allows the address-

ing of RAM (256 bytes for the ST631xx family), EEPROM (128 bytes), ST631xx Core/peripheral registers, and read-only data such as constants and the look-up tables.

Figure 12. ST631xx Data Space

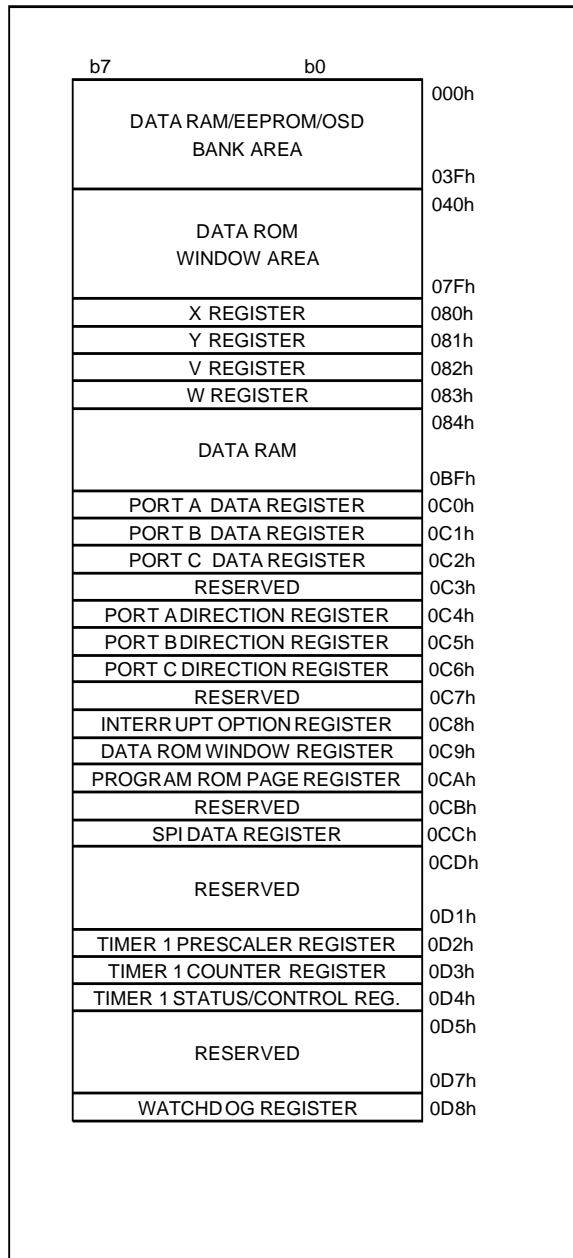
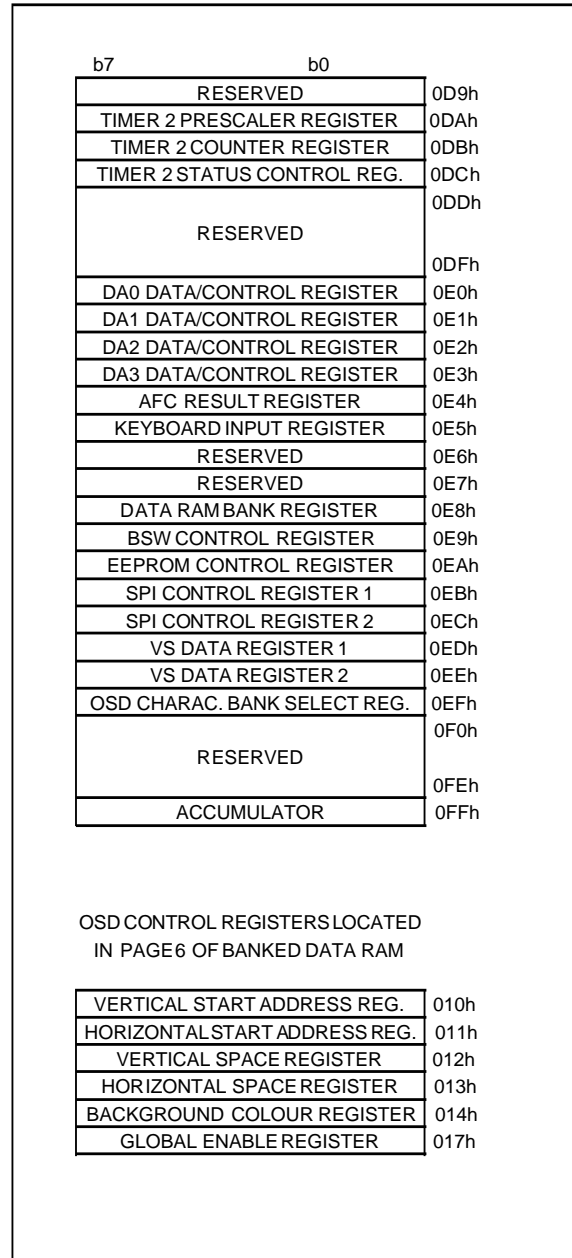

Figure 13. ST631xx Data Space (Continued)



MEMORY SPACES (Continued)

Data ROM Addressing. All the read-only data are physically implemented in the ROM in which the Program Space is also implemented. The ROM therefore contains the program to be executed and also the constants and the look-up tables needed for the program. The locations of Data Space in which the different constants and look-up tables are addressed by the ST631xx Core can be considered as being a 64-byte window through which it is possible to access to the read-only data stored in the ROM. This window is located from address 40H to address 7Fh in the Data space and allows the direct reading of the bytes from the address 000h to address 03Fh in the ROM. All the bytes of the ROM can be used to store either instructions or read-only data. Indeed, the window can be moved by step of 64 bytes along the ROM in writing the appropriate code in the Write-only Data ROM Window register (DRWR, location C9h). The effective address of the byte to be read as a data in the ROM is obtained by the concatenation of the 6 less significant bits of the address in the Data Space (as less significant bits) and the content of the DRWR (as most significant bits). So when addressing location 40h of data space, and 0 is loaded in the DRWR, the physical addressed location in ROM is 00h.

Figure 14. Data ROM Window Register

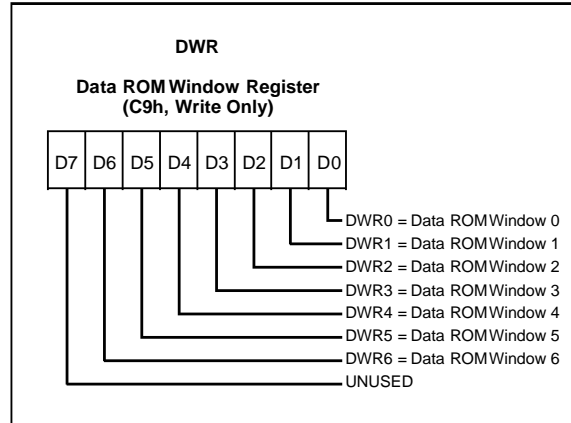

D7. This bit is not used.

DWR6-DWR0. These are the Data Rom Window bits that correspond to the upper bits of data ROM program space. This register is undefined after reset.

This register is undefined on reset. Neither read nor single bit instructions may be used to address this register.

Note. Care is required when handling the DRWR as it is write only. For this reason, it is not allowed to change the DRWR contents while executing interrupts drivers, as the driver cannot save and then restore its previous content. If it is impossible to avoid the writing of this register in interrupts drivers, an image of this register must be saved in a RAM location, and each time the program writes the DRWR it writes also the image register. The image register must be written first, so if an interrupt occurs between the two instructions the DRWR register is not affected.

Figure 15. Data ROM Window Memory Addressing

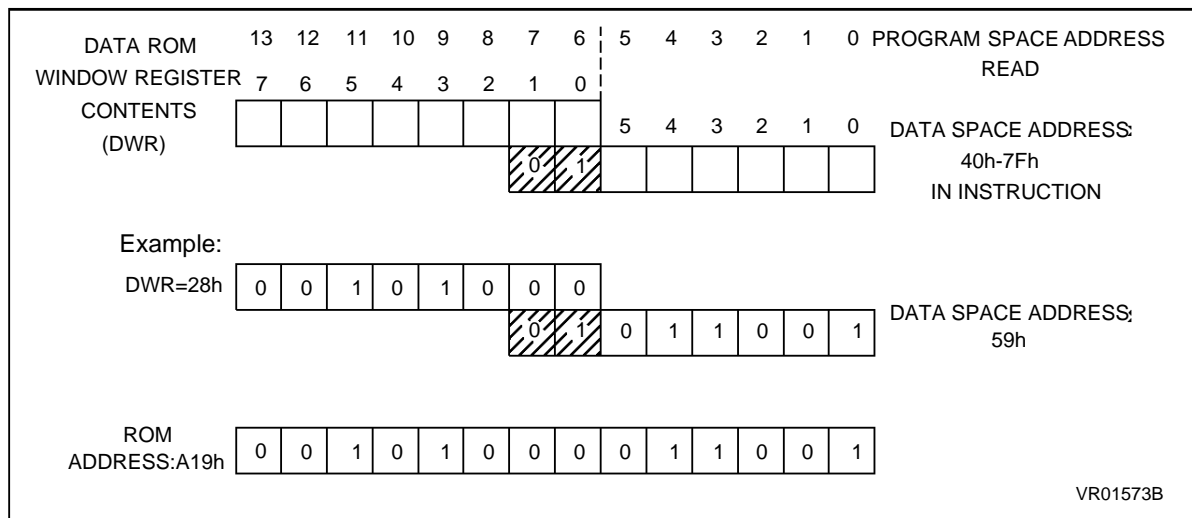

MEMORY SPACES (Continued)

Data RAM/EEPROM/OSD RAM Addressing

In all members of the ST631xx family 64 bytes of data RAM are directly addressable in the data space from 80h to BFh addresses. The additional 192 bytes of RAM, the 128 bytes of EEPROM, and the OSD RAM can be addressed using the banks of 64 bytes located between addresses 00h and 3Fh. The selection of the bank is done by programming the Data RAM Bank Register (DRBR) located at the E8h address of the Data Space. In this way each bank of RAM, EEPROM or OSD RAM can select 64 bytes at a time. No more than one bank should be set at a time.

D7. This bit is not used.

DRBR6, DRBR5. Each of these bits, when set, will select one OSD RAM register page.

DRBR4, DRBR3, DRBR2. Each of these bits, when set, will select one RAM page.

DRBR1, DRBR0. These bits select the EEPROM pages.

This register is undefined after reset. Neither read nor single bit instructions may be used to address this register.

Table 5 summarizes how to set the Data RAM Bank Register in order to select the various banks or pages.

Figure 16. Data RAM Bank Register

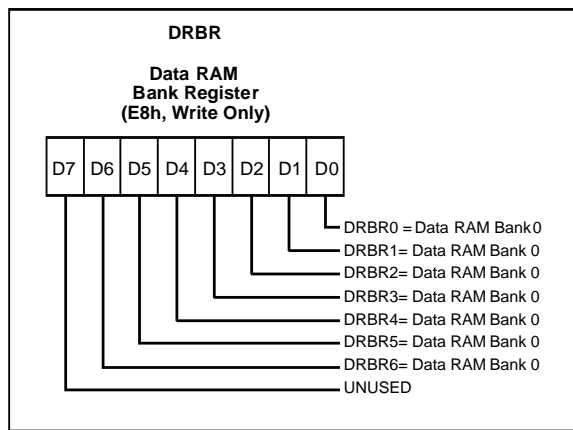

Note :

Care is required when handling the DRBR as it is write only. For this reason, it is not allowed to change the DRBR contents while executing interrupts drivers, as the driver cannot save and then restore its previous content. If it is impossible to avoid the writing of this register in interrupts drivers, an image of this register must be saved in a RAM location, and each time the program writes the DRBR it writes also the image register. The image register must be written first, so if an interrupt occurs between the two instructions the DRBR is not affected.

Table 5. Data RAM Bank Register Set-up

DRBR Value		Selection
Hex.	Binary	
01h	0000 0001	EEPROM Page 0
02h	0000 0010	EEPROM Page 1
04h	0000 0100	RAM Page 2
08h	000 1000	RAM Page 3
10h	0001 0000	RAM Page 4
20h	0010 0000	OSD Page 5
40h	0100 0000	OSD Page 6

MEMORY SPACES (Continued)**EEPROM Description**

The data space of ST631xx family from 00h to 3Fh is paged as described in Table 5. 128 bytes of EEPROM located in 2 pages of 64 bytes (pages 0, and 1, see Table 5).

Through the programming of the Data RAM Bank Register (DRBR=E8h) the user can select the bank or page leaving unaffected the way to address the static registers. The way to address the "dynamic" page is to set the DRBR as described in Table 5 (e.g. to select EEPROM page 0, the DRBR has to be loaded with content 01h, see Data RAM/EEPROM/OSD RAM addressing for additional information). Bits 0 and 1 of the DRBR are dedicated to the EEPROM.

The EEPROM pages do not require dedicated instructions to be accessed in reading or writing. The EEPROM is controlled by the EEPROM Control Register (EECR=EAh). Any EEPROM location can be read just like any other data location, also in terms of access time.

To write an EEPROM location takes an average time of 5 ms (10ms max) and during this time the EEPROM is not accessible by the Core. A busy flag can be read by the Core to know the EEPROM status before trying any access. In writing the EEPROM can work in two modes: Byte Mode (BMODE) and Parallel Mode (PMODE). The BMODE is the normal way to use the EEPROM and consists in accessing one byte at a time. The PMODE consists in accessing 8 bytes per time.

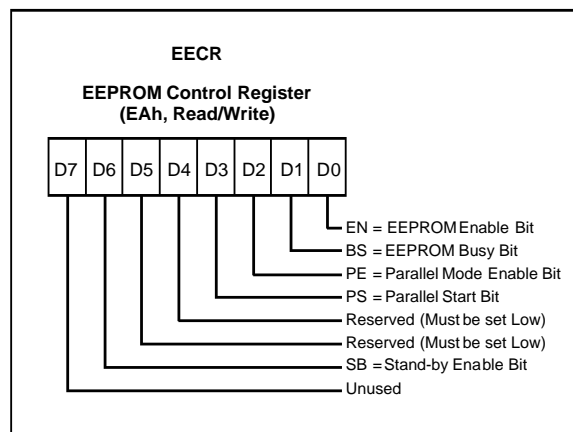
Figure 17. EEPROM Control Register

D7. Not used

SB. WRITE ONLY. If this bit is set the EEPROM is disabled (any access will be meaningless) and the power consumption of the EEPROM is reduced to the leakage values.

D5, D4. Reserved, they must be set to zero.

PS. SET ONLY. Once in Parallel Mode, as soon as the user software sets the PS bit the parallel writing of the 8 adjacent registers will start. PS is internally reset at the end of the programming procedure. Note that less than 8 bytes can be written; after parallel programming the remaining undefined bytes will have no particular content.

PE. WRITE ONLY. This bit must be set by the user program in order to perform parallel programming (more bytes per time). If PE is set and the "parallel start bit" (PS) is low, up to 8 adjacent bytes can be written at the maximum speed, the content being stored in volatile registers. These 8 adjacent bytes can be considered as row, whose A7, A6, A5, A4, A3 are fixed while A2, A1 and A0 are the changing bytes. PE is automatically reset at the end of any parallel programming procedure. PE can be reset by the user software before starting the programming procedure, leaving unchanged the EEPROM registers.

BS. READ ONLY. This bit will be automatically set by the CORE when the user program modifies an EEPROM register. The user program has to test it before any read or write EEPROM operation; any attempt to access the EEPROM while "busy bit" is set will be aborted and the writing procedure in progress completed.

EN. WRITE ONLY. This bit MUST be set to one in order to write any EEPROM register. If the user program will attempt to write the EEPROM when EN="0" the involved registers will be unaffected and the "busy bit" will not be set.

After RESET the content of EECR register will be 00h.

Notes :

When the EEPROM is busy (BS="1") the EECR can not be accessed in write mode, it is only possible to read BS status. This implies that as long as the EEPROM is busy it is not possible to change the status of the EEPROM control register. EECR bits 4 and 5 are reserved for test purposes, and must never be set to "1".

MEMORY SPACES (Continued)

Additional Notes on Parallel Mode. If the user wants to perform a parallel programming the first action should be the set to one the PE bit; from this moment the first time the EEPROM will be addressed in writing, the ROW address will be latched and it will be possible to change it only at the end of the programming procedure or by resetting PE without programming the EEPROM. After the ROW address latching the Core can “see” just one EEPROM row (the selected one) and any attempt to write or read other rows will produce errors. Do not read the EEPROM while PE is set.

As soon as PE bit is set, the 8 volatile ROW latches are cleared. From this moment the user can load data in the whole ROW or just in a subset. PS setting will modify the EEPROM registers corresponding to the ROW latches accessed after PE. For example, if the software sets PE and accesses EEPROM in writing at addresses 18h,1Ah,1Bh and then sets PS, these three registers will be modified at the same time; the remaining bytes will have no particular content. Note that PE is internally reset at the end of the programming procedure. This implies that the user must set PE bit between two parallel programming procedures. Anyway the user can set and then reset PE without performing any EEPROM programming. PS is a set only bit and is internally reset at the end of the programming procedure. Note that if the user tries to set PS while PE is not set there will not be any programming procedure and the PS bit will be unaffected. Consequently PS bit can not be set if EN is low. PS can be affected by the user set if, and only if, EN and PE bits are also set to one.

STACK SPACE

The stack space consists of six 12 bit registers that are used for stacking subroutine and interrupt return addresses plus the current program counter register.

INTERRUPT

The ST631xx Core can manage 4 different maskable interrupt sources, plus one non-maskable interrupt source (top priority level interrupt). Each source is associated with a particular interrupt vector that contains a Jump instruction to the related interrupt service routine. Each vector is located in the Program Space at a particular address (see Table 6). When a source provides an interrupt request, and the request processing is also enabled by the ST631xx Core, then the PC register is loaded with the address of the interrupt vector (i.e. of the Jump instruction). Finally, the PC is loaded with the address of the Jump instruction and the interrupt routine is processed.

The relationship between vector and source and the associated priority is hardware fixed for the different ST631xx devices. For some interrupt sources it is also possible to select by software the kind of event that will generate the interrupt.

All interrupts can be disabled by writing to the GEN bit (global interrupt enable) of the interrupt option register (address C8h). After a reset, ST631xx is in non maskable interrupt mode, so no interrupts will be accepted and NMI flags will be used, until a RETI instruction is executed. If an interrupt is executed, one special cycle is made by the core, during that the PC is set to the related interrupt vector address. A jump instruction at this address has to redirect program execution to the beginning of the related interrupt routine. The interrupt detecting cycle, also resets the related interrupt flag (not available to the user), so that another interrupt can be stored for this current vector, while its driver is under execution.

If additional interrupts arrive from the same source, they will be lost. NMI can interrupt other interrupt routines at any time, while other interrupts cannot interrupt each other. If more than one interrupt is waiting for service, they are executed according to their priority. The lower the number, the higher the priority. Priority is, therefore, fixed. Interrupts are checked during the last cycle of an instruction (RETI included). Level sensitive interrupts have to be valid during this period.

INTERRUPT (Continued)**Table 6.** Interrupt Vectors/Sources Relationships

Interrupt Source	Associated Vector	Vector Address
IRIN/NMI Pin ⁽¹⁾	Interrupt Vector # 0 (NMI)	0FFCh-0FFDh
None ⁽²⁾	Interrupt Vector # 1	0FF6h-0FF7h
Vsync	Interrupt Vector # 2	0FF4h-0FF5h
Timer 1	Interrupt Vector # 3	0FF2h-0FF3h
Timer 2	Interrupt Vector # 4	0FF0h-0FF1h

Notes:

1. This pin is associated with the NMI Interrupt Vector
2. This vector is not used in ST631xx.

Interrupt Vectors/Sources

The ST631xx Core includes 5 different interrupt vectors in order to branch to 5 different interrupt routines. The interrupt vectors are located in the fixed (or static) page of the Program Space.

The interrupt vector associated with the non-maskable interrupt source is named interrupt vector #0. It is located at addresses FFCh,FFDh in the Program Space. This vector is associated with the PC6/IRIN pin.

The interrupt vectors located at addresses (FF6h,FF7h), (FF4h,FF5h), (FF2h,FF3h), (FF0h,FF1h) are named interrupt vectors #1, #2, #3 and #4 respectively. These vectors are associated with TIMER 2 (#4), VSYNC (#2), and TIMER 1 (#3). Interrupt vector (#1) is not used on ST631xx.

Interrupt Priority

The non-maskable interrupt request has the highest priority and can interrupt any other interrupt routines at any time, nevertheless the other interrupts cannot interrupt each other. If more than one interrupt request is pending, they are processed by the ST631xx Core according to their priority level: vector #1 has the higher priority while vector #4 the lower. The priority of each interrupt source is hardware fixed.

Interrupt Option Register

The Interrupt Option Register (IOR register, location C8h) is used to enable/disable the individual interrupt sources and to select the operating mode of the external interrupt inputs. This register can be addressed in the Data Space as RAM location at the C8h address, nevertheless it is write-only register that can not be accessed with single-bit operations. The operating modes of the external interrupt inputs associated to interrupt vectors #1 and #2 are selected through bits 5 and 6 of the IOR register.

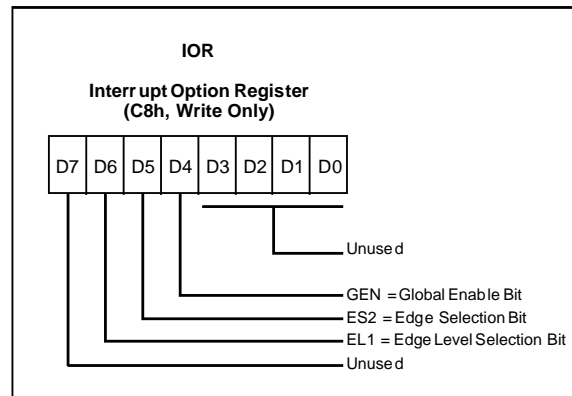
Figure 18. Interrupt Option Register

D7. Not used.

EL1. This is the Edge/Level selection bit of interrupt #1. When set to one, the interrupt is generated on low level of the related signal; when cleared to zero, the interrupt is generated on falling edge. The bit is cleared to zero after reset and as no interrupt source is associated to vector #1 on ST631xx, the user must keep this bit at zero to avoid ghost interrupts from this source.

ES2. This is the edge selection bit on interrupt #2. This bit is used on the ST631xx devices with on-chip OSD generator for VSYNC detection.

GEN. This is the global enable bit. When set to one all interrupts are globally enabled; when this bit is cleared to zero all interrupts are disabled (EXcluding NMI).

D3 - D0. These bits are not used.

INTERRUPT (Continued)

Interrupt Procedure. The interrupt procedure is very similar to a call procedure, indeed the user can consider the interrupt as an asynchronous call procedure. As this is an asynchronous event the user does not know about the context and the time at which it occurred. As a result the user should save all the data space registers which will be used inside the interrupt routines. There are separate sets of processor flags for normal, interrupt and non-maskable interrupt modes which are automatically switched and so these do not need to be saved.

The following list summarizes the interrupt procedure:

ST631xx actions

- Interrupt detection
- The flags C and Z of the main routine are exchanged with the flags C and Z of the interrupt routine (or the NMI flags)
- The value of the PC is stored in the first level of the stack
- The normal interrupt lines are inhibited (NMI still active)
- First internal latch is cleared
- The related interrupt vector is loaded in the PC.

User actions

- User selected registers are saved inside the interrupt service routine (normally on a software stack)
- The source of the interrupt is found by polling (if more than one source is associated to the same vector) the interrupt flag of the source.
- Interrupt servicing
- Return from interrupt (RETI)

ST631xx actions

- Automatically the ST631xx core switches back to the normal flags (or the interrupt flags) and pops the previous PC value from the stack

The interrupt routine begins usually by the identification of the device that has generated the interrupt request (by polling). The user should save the registers which are used inside the interrupt routine (that holds relevant data) into a software stack. After the RETI instruction execution, the core carries out the previous actions and the main routine can continue.

Figure 19. Interrupt Processing Flow-Chart

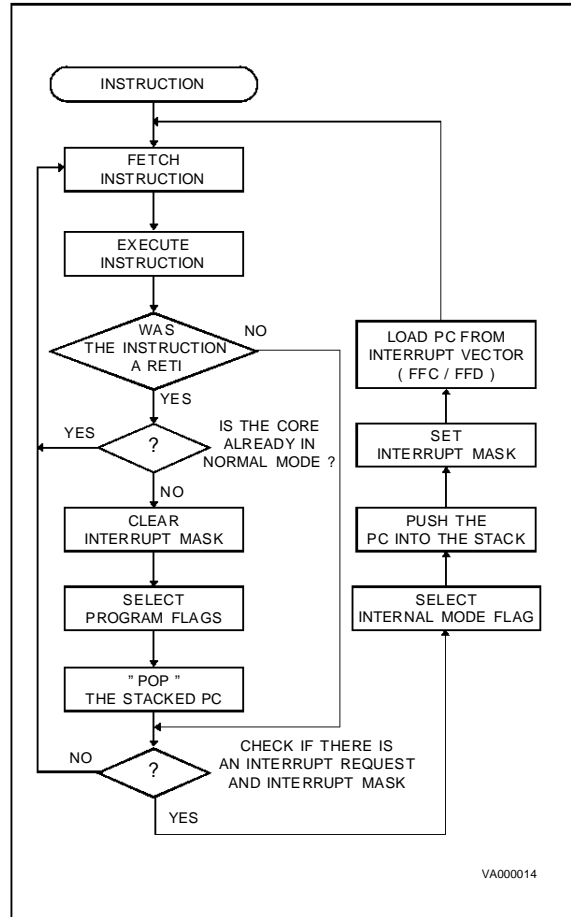

ST631xx Interrupt Details

IR Interrupt (#0). The IRIN Interrupt is connected to the first interrupt #0 (NMI, 0FFCh). If enabled, then an interrupt will be generated on a rising edge at the pin.

Interrupt (#1). On ST631xx no sources are associated to vector (#1). To avoid any ghost interrupt due to interrupt (#1) the user must keep the EL1 bit of IOR register to zero.

INTERRUPT (Continued)

VSYNC Interrupt (#2). The VSYNC Interrupt is connected to the interrupt #2. When disabled the VSYNC INT signal is low. Bit 5 of the interrupt option register C8h is used to select the negative edge (ES2=0) or the positive edge (ES2=1); the edge will depend on the application. Note that once an edge has been latched, then the only way to remove the latched signal is to service the interrupt. Care must be taken not to generate spurious interrupts. This interrupt may be used for synchronize to the VSYNC signal in order to change characters in the OSD only when the screen is on vertical blanking (if desired). This method may also be used to blink characters.

TIMER 1 Interrupt (#3). The TIMER 1 Interrupt is connected to the fourth interrupt #3 (0FF2h) which detects a low level (latched in the timer).

TIMER 2 Interrupt (#4). The TIMER 2 Interrupt is connected to the fifth interrupt #4 (0FF0h) which detects a high to low level (latched in the timer).

Notes: Global disable does not reset edge sensitive interrupt flags. These edge sensitive interrupts become pending again when global disabling is released. Moreover, edge sensitive interrupts are stored in the related flags also when interrupts are globally disabled, unless each edge sensitive interrupt is also individually disabled before the interrupting event happens. Global disable is done by clearing the GEN bit of Interrupt option register, while any individual disable is done in the control register of the peripheral. The on-chip Timer peripherals have an interrupt request flag bit (TMZ), this bit is set to one when the device wants to generate an interrupt request and a mask bit (ETI) that must be set to one to allow the transfer of the flag bit to the Core.

RESET

The ST631xx device can be reset in two ways: by the external reset input (RESET) tied low, by power-on reset and by the digital Watchdog peripheral.

RESET Input

The external active low RESET pin is used to reset the ST631xx devices and provide an orderly software startup procedure. The activation of the RESET pin may occur in the RUN or WAIT mode. Even short pulses at the reset pin will be accepted since the reset signal is latched internally and is only cleared after 2048 clocks at the oscillator pin. The clocks from the oscillator pin to the reset circuitry are buffered by a Schmitt Trigger so that an oscillator in start-up conditions will not give spurious clocks. The MCU is configured in the Reset mode as long as the signal of the RESET pin is low. The processing of the program is stopped and the standard Input/Outputports (port A, port B and port C) are in the input state (except PC2). As soon as the level on the RESET pin becomes high, the initialization sequence is executed.

Watchdog Reset

The ST631xx devices are provided with an on-chip hardware activated digital watchdog function in order to provide a graceful recovery from a software upset. If the watchdog register is not refreshed and the end-of-count is reached, then the reset state will be latched into the MCU and an internal circuit pulls down the RESET pin. This also resets the watchdog which subsequently turns off the pull-down and activates the pull-up device at the RESET pin. This causes the positive transition at the RESET pin. The MCU will then exit the reset state after 2048 clocks on the oscillator pin.

Application Notes

An external resistor between V_{DD} and reset pin is not required because an internal pull-up device is provided. The user may prefer to add an external pull-up resistor.

An internal Power-on device does not guarantee that the MCU will exit the reset state when V_{DD} is above 4.5V and therefore the RESET pin should be externally controlled.

Figure 20. Internal Reset Circuit

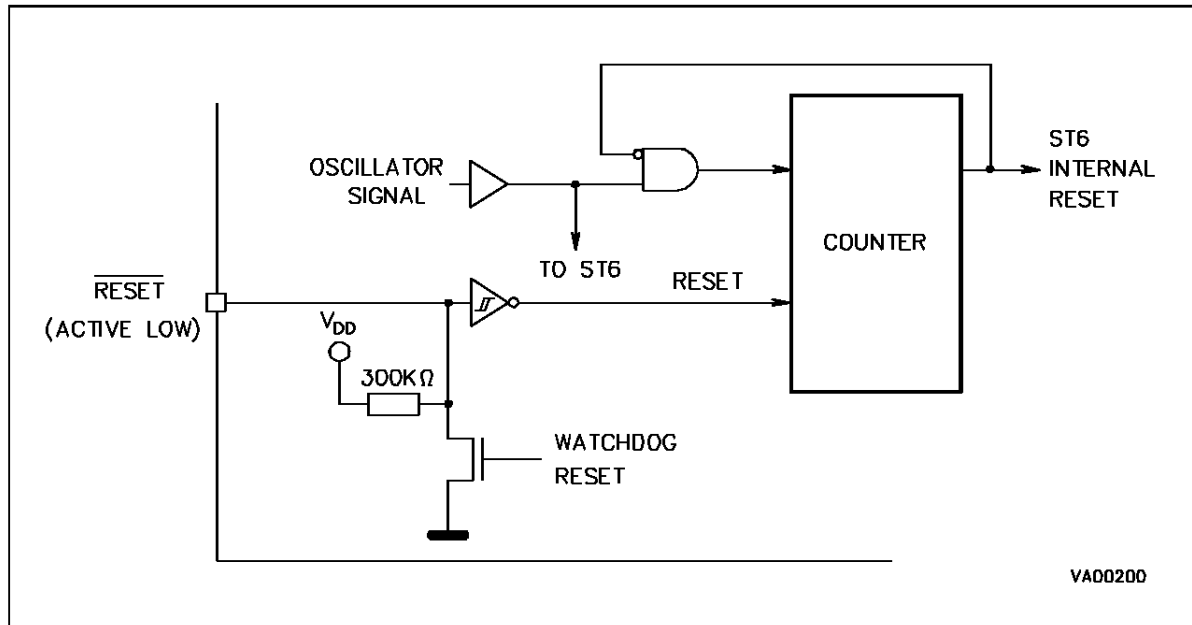

RESET (Continued)

Figure 21. Reset & Interrupt Processing Flow-Chart

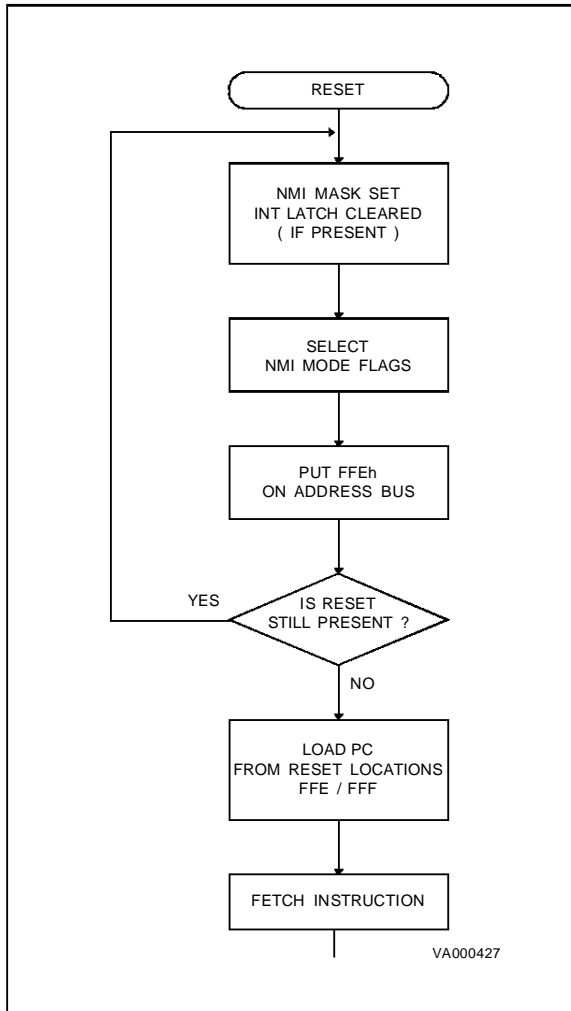
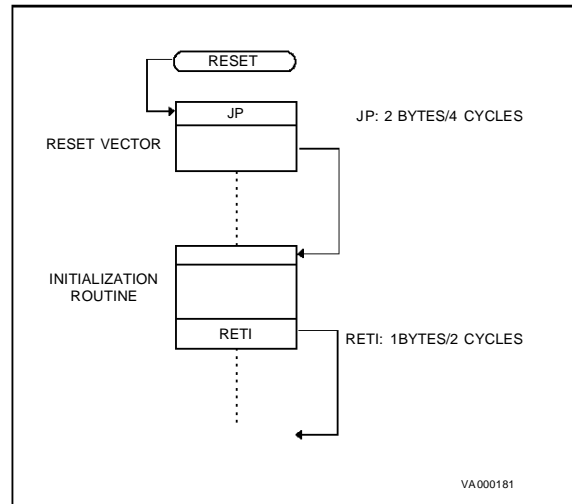

Figure 22. Restart Initialization Program Flow-Chart



MCU Initialization Sequence

When a reset occurs the stack is reset to the program counter, the PC is loaded with the address of the reset vector (located in the program ROM at addresses FFEh & FFFh). A jump instruction to the beginning of the program has to be written into these locations. After a reset a NMI is automatically activated so that the core is in non-maskable interrupt mode to prevent false or ghost interrupts during the restart phase. Therefore the restart routine should be terminated by a RETI instruction to switch to normal mode and enable interrupts. If no pending interrupt is present at the end of the reset routine the ST631xx will continue with the instruction after the RETI; otherwise the pending interrupt will be serviced.

WAIT & STOP MODES

The STOP and WAIT modes have been implemented in the ST631xx Core in order to reduce the consumption of the device when the latter has no instruction to execute. These two modes are described in the following paragraphs. On ST631xx as the hardware activated digital watchdog function is present the STOP instruction is de-activated and any attempt to execute it will cause the automatic execution of a WAIT instruction.

WAIT Mode

The configuration of the MCU in the WAIT mode occurs as soon as the WAIT instruction is executed. The microcontroller can also be considered as being in a "software frozen" state where the Core stops processing the instructions of the routine, the contents of the RAM locations and peripheral registers are saved as long as the power supply voltage is higher than the RAM retention voltage but where the peripherals are still working. The WAIT mode is used when the user wants to reduce the consumption of the MCU when it is in idle, while not losing count of time or monitoring of external events. The oscillator is not stopped in order to provide clock signal to the peripherals. The timers counting may be enabled (writing the PSI bit in TSCR register) and the timer interrupt may be also enabled before entering the WAIT mode; this allows the WAIT mode to be left when timer interrupt occurs. If the exit from the WAIT mode is performed with a general RESET (either from the activation of the external pin or by watchdog reset) the MCU will enter a normal reset procedure as described in the RESET chapter. If an interrupt is generated during WAIT mode the MCU behaviour depends on the state of the ST631xx Core before the initialization of the WAIT sequence, but also of the kind of the interrupt request that is generated. This case will be described in the following paragraphs. In any case, the ST631xx Core does not generate any delay after the occurrence of the interrupt because the oscillator clock is still available.

STOP Mode

On ST631xx the hardware watchdog is present and the STOP instruction has been de-activated. Any attempt to execute a STOP will cause the automatic execution of a WAIT instruction.

Exit from WAIT Mode

The following paragraphs describe the output procedure of the ST631xx Core from WAIT mode when an interrupt occurs. It must be noted that the restart sequence depends on the original state of

the MCU (normal, interrupt or non-maskable interrupt mode) before the start of the WAIT sequence, but also of the type of the interrupt request that is generated. In all cases the GEN bit of IOR has to be set to 1 in order to restart from WAIT Mode. Contrary to the operation of NMI in the RUN Mode, the NMI is masked in WAIT Mode if GEN=0.

Normal Mode. If the ST631xx Core was in the main routine when the WAIT instruction has been executed, the ST631xx Core outputs from the wait mode as soon as any interrupt occurs; the related interrupt routine is executed and at the end of the interrupt service routine the instruction that follows the WAIT instruction is executed if no other interrupts are pending.

Non-maskable Interrupt Mode. If the WAIT instruction has been executed during the execution of the non-maskable interrupt routine, the ST631xx Core outputs from the wait mode as soon as any interrupt occurs: the instruction that follows the WAIT instruction is executed and the ST631xx Core is still in the non-maskable interrupt mode even if another interrupt has been generated.

Normal Interrupt Mode. If the ST631xx Core was in the interrupt mode before the initialization of the WAIT sequence, it outputs from the wait mode as soon as any interrupt occurs. Nevertheless, two cases have to be considered:

- If the interrupt is a normal interrupt, the interrupt routine in which the WAIT was entered will be completed with the execution of the instruction that follows the WAIT and the ST631xx Core is still in the interrupt mode. At the end of this routine pending interrupts will be serviced in accordance to their priority.
- If the interrupt is a non-maskable interrupt, the non-maskable routine is processed at first. Then, the routine in which the WAIT was entered will be completed with the execution of the instruction that follows the WAIT and the ST631xx Core is still in the normal interrupt mode.

Notes :

If all the interrupt sources are disabled, the restart of the MCU can only be done by a Reset activation. The Wait instruction is not executed if an enabled interrupt request is pending. In the ST631xx the hardware activated digital watchdog function is present. As the watchdog is always activated the STOP instruction is de-activated and any attempt to execute the STOP instruction will cause an execution of a WAIT instruction.

ON-CHIP CLOCK OSCILLATOR

The internal oscillator circuit is designed to require a minimum of external components. A crystal quartz, a ceramic resonator, or an external signal (provided to the OSCin pin) may be used to generate a system clock with various stability/cost trade-offs. The typical clock frequency is 8MHz. Please note that different frequencies will affect the operation of those peripherals (D/As, SPI, 62.5 kHz OUT) whose reference frequencies are derived from the system clock.

The different clock generator options connection methods are shown in Figures 24 and 25. One machine cycle takes 13 oscillator pulses; 12 clock pulses are needed to increment the PC while and additional 13th pulse is needed to stabilize the internal latches during memory addressing. This means that with a clock frequency of 8MHz the machine cycle is 1.625µSec.

The crystal oscillator start-up time is a function of many variables: crystal parameters (especially RS), oscillator load capacitance (CL), IC parameters, ambient temperature, and supply voltage. It must be observed that the crystal or ceramic leads and circuit connections must be as short as possible. Typical values for CL1 and CL2 are in the range of 15pF to 22pF but these should be chosen based on the crystal manufacturers specification. Typical input capacitance for OSCin and OSCout pins is 5pF.

The oscillator output frequency is internally divided by 13 to produce the machine cycle and by 12 to produce the Timer and the Watchdog clock. A byte cycle is the smallest unit needed to execute any operation (i.e., increment the program counter). An instruction may need two, four, or five byte cycles to be executed (See Table 7).

Table 7. Instructions Timing with 8MHz Clock

Instruction Type	Cycles	Execution Time
Branch if set/reset	5 Cycles	8.125µs
Branch & Subroutine Branch	4 Cycles	6.50µs
Bit Manipulation	4 Cycles	6.50µs
Load Instruction	4 Cycles	6.50µs
Arithmetic & Logic	4 Cycles	6.50µs
Conditional Branch	2 Cycles	3.25µs
Program Control	2 Cycles	3.25µs

Figure 23. Clock Generator Option (1)

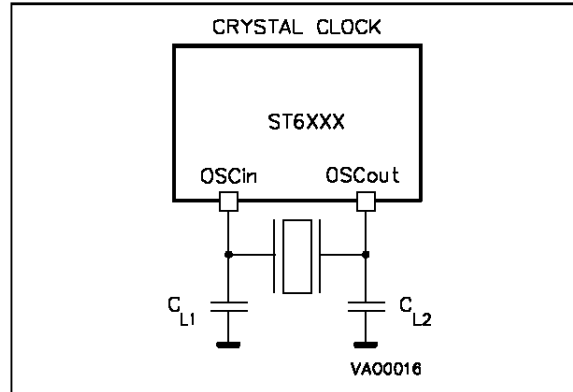

Figure 24. Clock Generator Option (2)

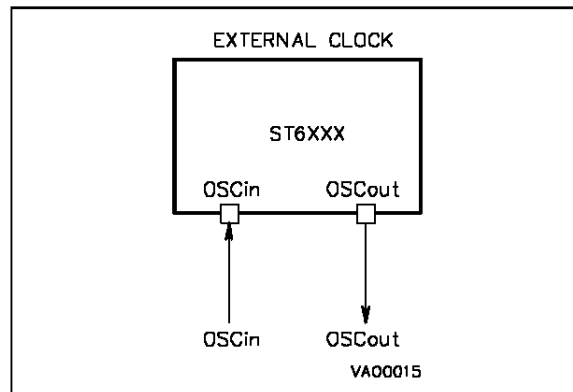
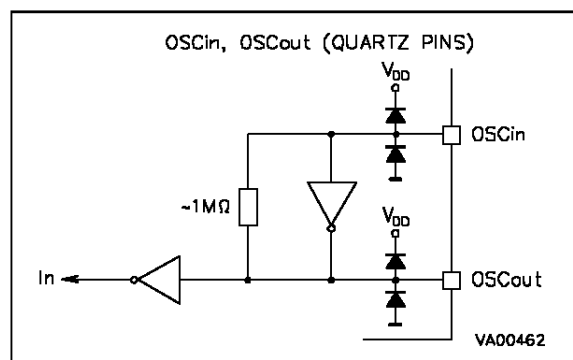

Figure 25. OSCin, OSCout Diagram



INPUT/OUTPUT PORTS

The ST631xx microcontrollers use three standard I/O ports (A,B,C) with up to eight pins on each port; refer to the device pin configurations to see which pins are available.

Each line can be individually programmed either in the input mode or the output mode as follows by software.

- Output
- Input with on-chip pull-up resistor (selected by software)
- Input without on-chip pull-up resistor (selected by software)

Note: pins with 12V open-drain capability do not have pull-up resistors.

In output mode the following hardware configurations are available:

- Open-drain output 12V (PA0-PA7)
- Open-drain output 5V (PB5-PB7, PC3, PC5-PC7)
- Push-pull output (PB0-PB4, PC0-PC2, PC4)

The lines are organized in three ports (port A,B,C). The ports occupy 6 registers in the data space. Each bit of these registers is associated with a particular line (for instance, the bits 0 of the Port A Data and Direction registers are associated with the PA0 line of Port A).

There are three Data registers (DRA, DRB, DRC), that are used to read the voltage level values of the lines programmed in the input mode, or to write the logic value of the signal to be output on the lines configured in the output mode. The port Data Registers can be read to get the effective logic levels of the pins, but they can be also written by the user software, in conjunction with the related Data Direction Register, to select the different input mode options. Single-bit operations on I/O registers (bit set/reset instructions) are possible but care is necessary because reading in input mode is made from I/O pins and therefore might be influenced by the external load, while writing will directly affect the Port data register causing an undesired changes of the input configuration. The three Data Direction registers (DDRA, DDRB, DDRC) allow the selection of the direction of each pin (input or output).

All the I/O registers can be read or written as any other RAM location of the data space. During the initialization of the MCU, all the I/O registers are cleared and the input mode with pull-up is selected on all the pins thus avoiding pin conflicts (with the exception of PC2 which is set in output mode and is set low).

Details of I/O Ports

When programmed as an input a pull-up resistor (if available) can be switched active under program control. When programmed as an output the I/O port will operate either in the push-pull mode or the open-drain mode according to the hardware fixed configuration as specified below.

Port A. PA0-PA7 are available as an open-drain only (no push-pull programmability and no resistive pull-up in input mode) capable of withstanding 12V while the normal open drain has standard ratings of $V_{DD} + 0.3V$. This I/O port has been specially designed for direct LED driving and is able to sink up to 30mA with a maximum V_{OL} of 1V.

Some Port B and C lines are also used as I/O buffers for signals coming from the on-chip SPI and OSD.

In this case the final signal on the output pin is equivalent to a wired AND with the programmed data output.

If the user needs to use the SPI or the OSD, then the I/O line should be set in output mode while the open-drain configuration is fixed in hardware ; the corresponding data bit must be set to one.

PB2 and PB3 must be programmed in input mode to provide the HSYNC and VSYNC input signals to the OSD.

On ST631xx the I/O pins with double or special functions are:

- PB2/VSYNC (connected to the OSD VSYNC signal)
- PB3/HSYNC (connected to the OSD HSYNC signal)
- PB5/SCL (connected to the SPI clock signal)
- PB6/SDA (connected to the SPI data signal)
- PB7/SEN (connected to the SPI enable signal)
- PC2-ON-OFF, this I/O is specially suited to TV SET ON-OFF and for this reason at reset the related Data Direction bit will be automatically set to one (I/O line is in output mode), while the rest of the port is in input mode
- PC3/BLANK (connected to the OSD Blank signal)
- PC5/R, PC6/G, PC7/B (connected to the OSD R-G-B signals)

All the Port A,B and C I/O lines have Schmitt-trigger input configuration with a typical hysteresis of 1V.

INPUT/OUTPUT PORTS (Continued)

I/O Pin Programming

Each pin can be individually programmed as input or output with different input and output configurations. This is achieved by writing to the relevant bit in the data (DR) and data direction register (DDR). Table 8 shows all the port configurations that can be selected by the user software.

Figure 24. Port A, B, C Data Register

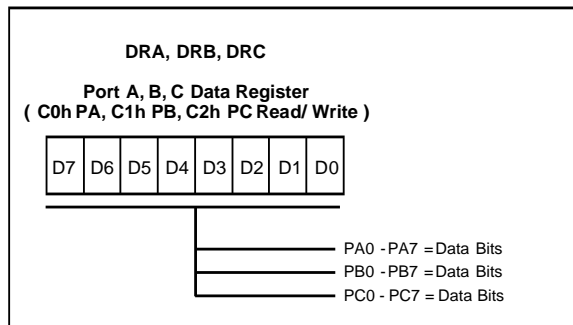

PA7-PA0. These are the I/O port A data bits. Reset at power-on.

PB7-PB0. These are the I/O port B data bits. Reset at power-on.

PC7-PC0. These are the I/O port C data bits. Reset at power-on.

Figure 25. Port A, B, C Data Direction Register

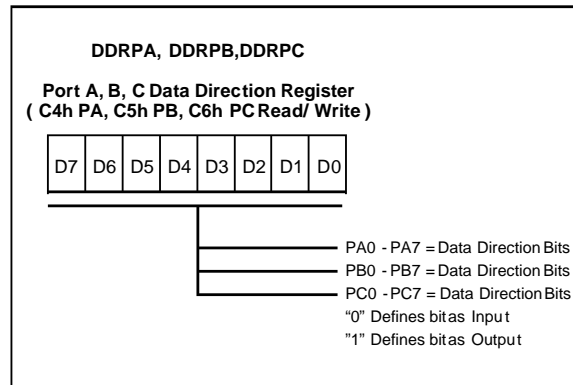

PA7-PA0. These are the I/O port A data direction bits. When a bit is cleared to zero the related I/O line is in input mode, if bit is set to one the related I/O line is in output mode. Reset at power-on.

PB7-PB0. These are the I/O port B data direction bits. When a bit is cleared to zero the related I/O line is in input mode, if bit is set to one the related I/O line is in output mode. Reset at power-on.

PC7-PC0. These are the I/O port C data direction bits. When a bit is cleared to zero the related I/O line is in input mode, if bit is set to one the related I/O line is in output mode. Set to 04h at power-on. Bit 2 (PC2 pin) is set to one (output mode selected) as this line is intended for TV ON-OFF switching.

Table 8. I/O Port Options Selection

DDR	DR	Mode	Option
0	0	Input	With on-chip pull-up resistor
0	1	Input	Without on-chip pull-up resistor
1	X	Output	Open-drain or Push-Pull

Note: X: Means don't care.

INPUT/OUTPUT PORTS (Continued)

Input/Output Configurations

The following schematics show the I/O lines hardware configuration for the different options. Figure 30 shows the I/O configuration for an I/O pin with open-drain 12V capability (standard drive and high drive). Figure 31 shows the I/O configuration for an I/O pin with push-pull and with open drain 5V capability.

Notes :

The WAIT instruction allows the ST631xx to be used in situations where low power consumption is needed. This can only be achieved however if the I/O pins either are programmed as inputs with well defined logic levels or have no power consuming resistive loads in output mode. As the same die is used for the different ST631xx versions the unavailable I/O lines of ST631xx should be programmed in output mode.

Single-bit operations on I/O registers are possible but **care is necessary** because reading in input mode is made from I/O pins while writing will directly affect the Port data register causing an undesired changes of the input configuration.

Figure 26. I/O Configuration Diagram (Open Drain 12V)

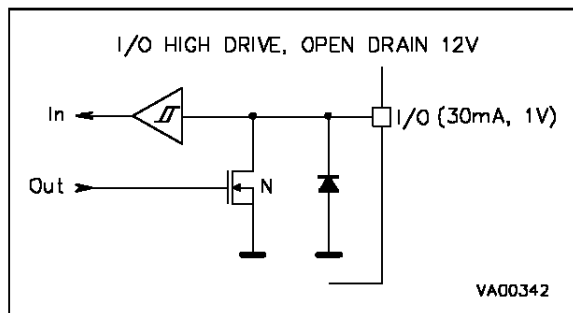
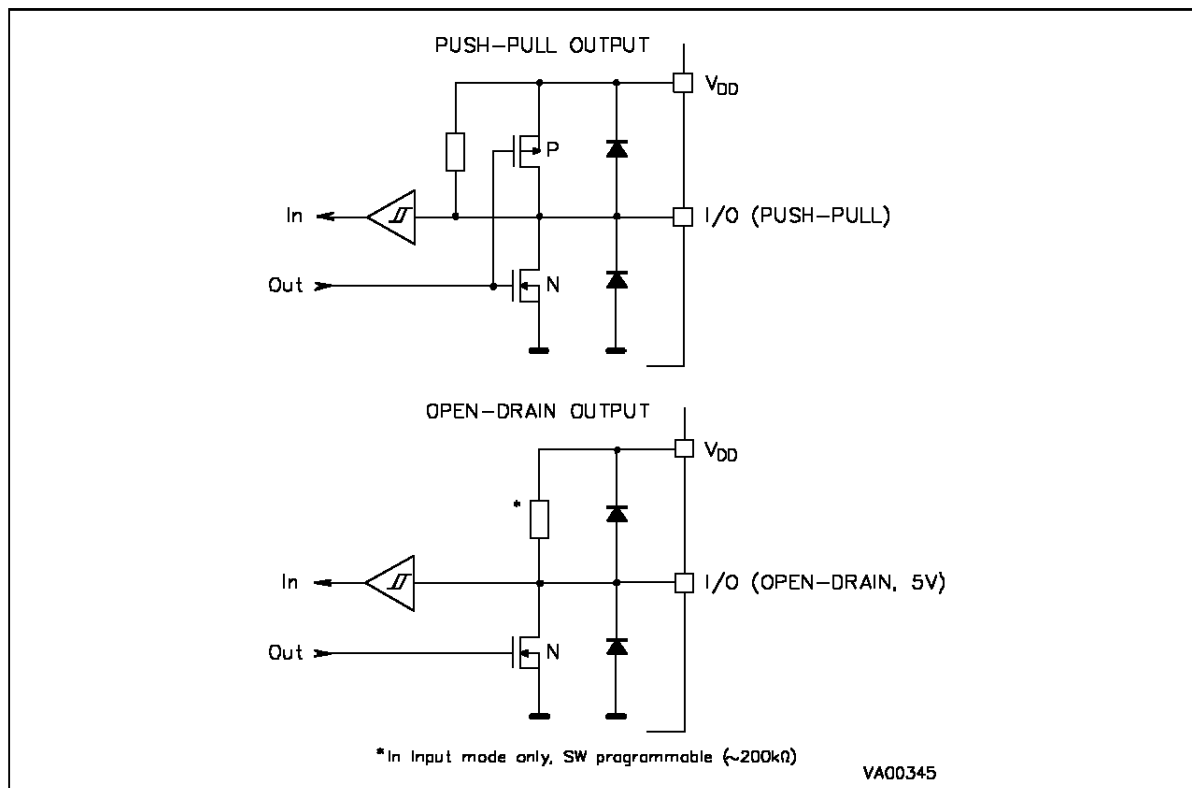

Figure 27. I/O Configuration Diagram (Open Drain 5V, Push-pull)



TIMERS

The ST631xx devices offer two on-chip Timer peripherals consisting of an 8-bit counter with a 7-bit programmable prescaler, thus giving a maximum count of 2^{15} , and a control logic that allows configuring the peripheral operating mode. Figure 30 shows the timer block diagram. The content of the 8-bit counters can be read/written in the Timer/Counter registers TCR that can be addressed in the data space as RAM location at addresses D3h (Timer 1) and DBh (Timer 2). The state of the 7-bit prescaler can be read in the PSC register at addresses D2h (Timer 1) and DAh (Timer 2). The control logic is managed by TSCR registers at D4h (Timer 1) and DCh (Timer 2) addresses as described in the following paragraphs.

The following description applies to both Timer 1 and Timer 2. The 8-bit counter is decremented by the output (rising edge) coming from the 7-bit prescaler and can be loaded and read under program control. When it decrements to zero then the TMZ (timer zero) bit in the TSCR is set to one. If the ETI (enable timer interrupt) bit in the TSCR is also set to one an interrupt request, associated to interrupt vector #3 (for Timer 1) and #1 for Timer 2, is generated. The interrupt of the timer can be used to exit the MCU from the WAIT mode.

The prescaler decrements on rising edge. The prescaler input is the oscillator frequency divided by 12 or an external clock at TIMER pin (this is not available in ST631xx).

Depending on the division factor programmed by PS2/PS1/PS0 (see table 9) bits in the TSCR, the clock input of the timer/counter register is multiplexed to different sources.

On division factor 1, the clock input of the prescaler is also that of timer/counter; on factor 2, bit 0 of prescaler register is connected to the clock input of TCR.

This bit changes its state with the half frequency of prescaler clock input. On factor 4, bit 1 of PSC is connected to clock input of TCR, and so on. On division factor 128, the MSB bit 6 of PSC is connected to clock input of TCR. The prescaler initialize bit (PSI) in the TSCR register must be set to one to allow the prescaler (and hence the counter) to start. If it is cleared to zero then all of the prescaler bits are set to one and the counter is inhibited from counting.

The prescaler can be given any value between 0 and 7Fh by writing to the related register address, if bit PSI in the TSCR register is set to one. The tap of the prescaler is selected using the PS2/PS1/PS0 bits in the control register. Figure 33 shows the timer working principle.

Figure 28. Timer Peripheral Block Diagram

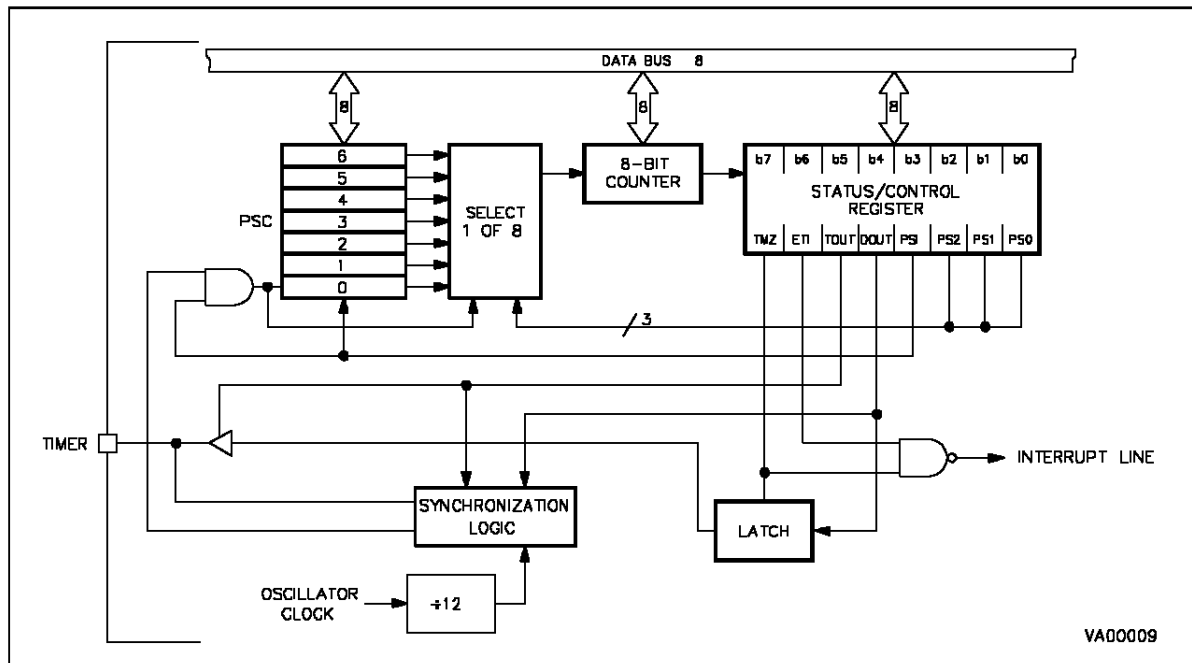

TIMERS (Continued)

Figure 29. Timer Working Principle

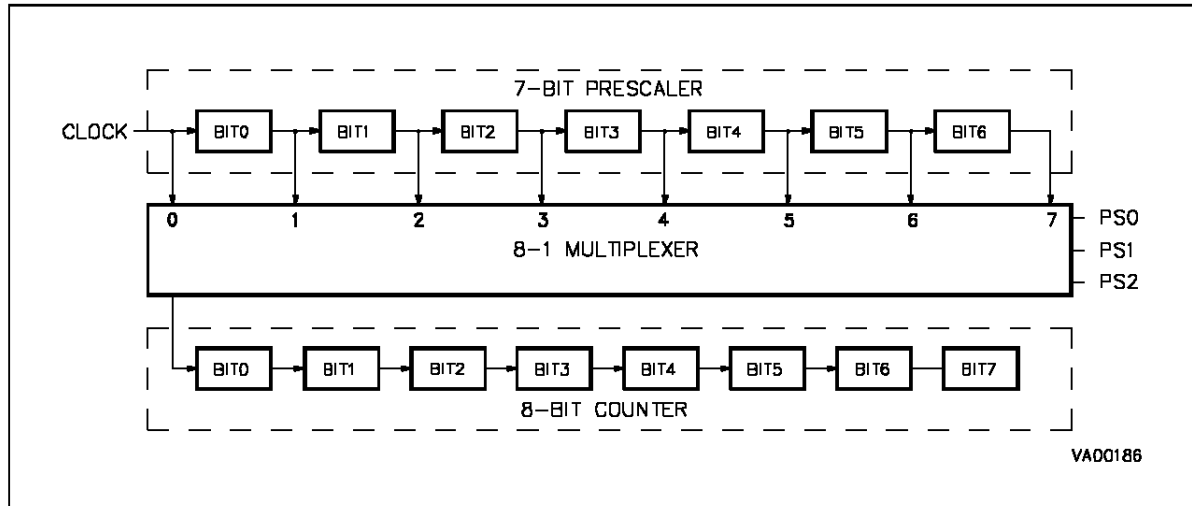

Timer Operating Modes

As the external TIMER pin is not available on ST631xx devices, the only allowed operating mode is the output mode that have to be selected by setting to 1 bit 4 and by clearing to 0 bit 5 in the TSCR1 register. This procedure will enable both Timer 1 and Timer 2.

Output Mode (TSCR1 D4 = 1, TSCR1 D5 = 0). On this mode the timer prescaler is clocked by the prescaler clock input (OSC/12). The user can select the desired prescaler division ratio through the PS2/PS1/PS0 bits. When TCR count reaches 0, it sets the TMZ bit in the TSCR.

The TMZ bit can be tested under program control to perform timer functions whenever it goes high. Bit D4 and D5 on TSCR2 (Timer 2) register are not implemented.

Timer Interrupt

When the counter register decrements to zero and the software controlled ETI (enable timer interrupt) bit is set to one then an interrupt request associated to interrupt vector #3 (for Timer 1) and to interrupt vector #4 (for Timer 2) is generated. When the counter decrements to zero also the TMZ bit in the TSCR register is set to one.

Notes :

TMZ is set when the counter reaches 00h ; however, it may be set by writing 00h in the TCR register or setting the bit 7 of the TSCR register. TMZ bit must be cleared by user software when servicing the timer interrupt to avoid undesired interrupts when leaving the interrupt service routine. After reset, the 8-bit counter register is loaded to FFh while the 7-bit prescaler is loaded to 7Fh , and the TSCR register is cleared which means that timer is stopped (PSI=0) and timer interrupt disabled.

A write to the TCR register will predominate over the 8-bit counter decrement to 00h function, i.e. if a write and a TCR register decrement to 00h occur simultaneously, the write will take precedence, and the TMZ bit is not set until the 8-bit counter reaches 00h again. The values of the TCR and the PSC registers can be read accurately at any time.

TIMERS (Continued)

Figure 30. Timer Status Control Registers

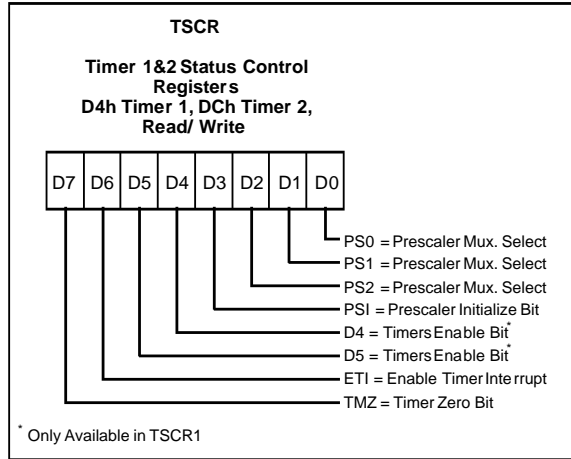

TMZ. Low-to-high transition indicates that the timer count register has decremented to zero. This bit must be cleared by user software before to start with a new count.

ETI. This bit, when set, enables the timer interrupt (vector #3 for Timer 1, vector #4 for Timer 2) request. If ETI=0 the timer interrupt is disabled. If ETI= 1 and TMZ= 1 an interrupt request is generated.

D5. This is the timers enable bit D5. It must be cleared to 0 together with a set to 1 of bit D4 to enable both Timer 1 and Timer 2 functions. It is not implemented on TSCR2 register.

D4. This is the timers enable bit D4. This bit must be set to 1 together with a clear to 0 of bit D5 to enable both Timer 1 and Timer 2 functions. It is not implemented on TSCR2 register.

D5	D4	Timers
0	0	Disabled
0	1	Enabled
1	X	Reserved

PSI. Used to initialize the prescaler and inhibit its counting while PSI = 0 the prescaler is set to 7Fh and the counter is inhibited. When PSI = 1 the prescaler is enabled to count downwards. As long as PSI= 0 both counter and prescaler are not running.

PS2-PS0. These bits select the division ratio of the prescaler register (see Table 9)

The TSCR1 and TSCR2 registers are cleared on reset. The correct D4-D5 combination must be written in TSCR1 by user's software to enable the operation of Timer 1 and Timer 2.

Table 9. Prescaler Division Factors

PS2	PS1	PS0	Divided By
0	0	0	1
0	0	1	2
0	1	0	4
0	1	1	8
1	0	0	16
1	0	1	32
1	1	0	64
1	1	1	128

Figure 31. Timer Counter Registers

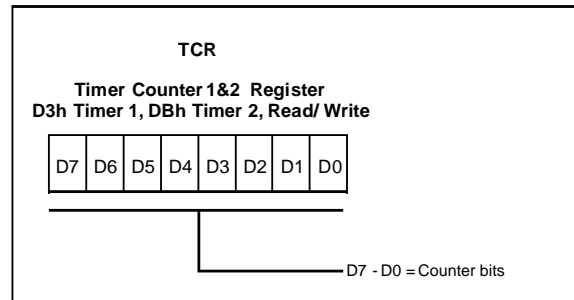
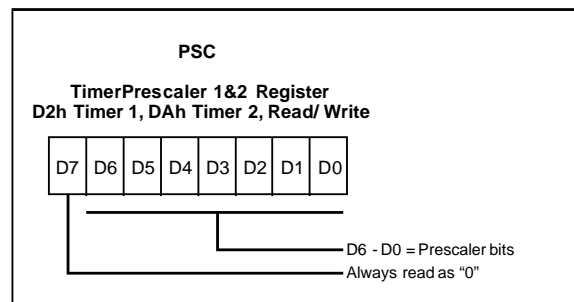

Figure 32. Timer Counter Registers



HARDWARE ACTIVATED DIGITAL WATCHDOG FUNCTION

The hardware activated digital watchdog function consists of a down counter that is automatically initialized after reset so that this function does not need to be activated by the user program. As the watchdog function is always activated this down counter can not be used as a timer. The watchdog is using one data space register (HWDR location D8h). The watchdog register is set to FEh on reset and immediately starts to count down, requiring no software start. Similarly the hardware activated watchdog can not be stopped or delayed by software.

The watchdog time can be programmed using the 6 MSbits in the watchdog register, this gives the possibility to generate a reset in a time between 3072 to 196608 oscillator cycles in 64 possible steps (With a clock frequency of 8MHz this means from 384µs to 24.576ms). The reset is prevented if the register is reloaded with the desired value before bits 2-7 decrement from all zeros to all ones.

The presence of the hardware watchdog deactivates the STOP instruction and a WAIT instruction is automatically executed instead of a STOP. Bit 1 of the watchdog register (set to one at reset) can be used to generate a software reset if cleared to zero).

Figure 34. Hardware Activated Watchdog Working Principle

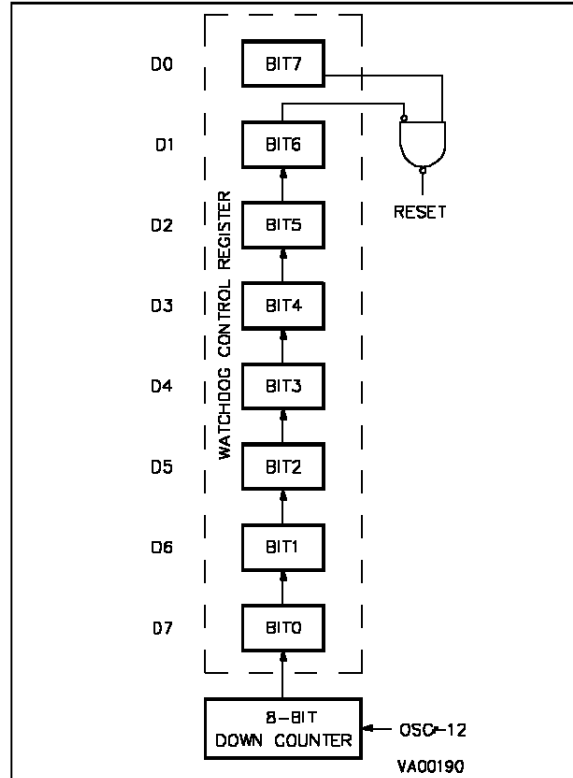
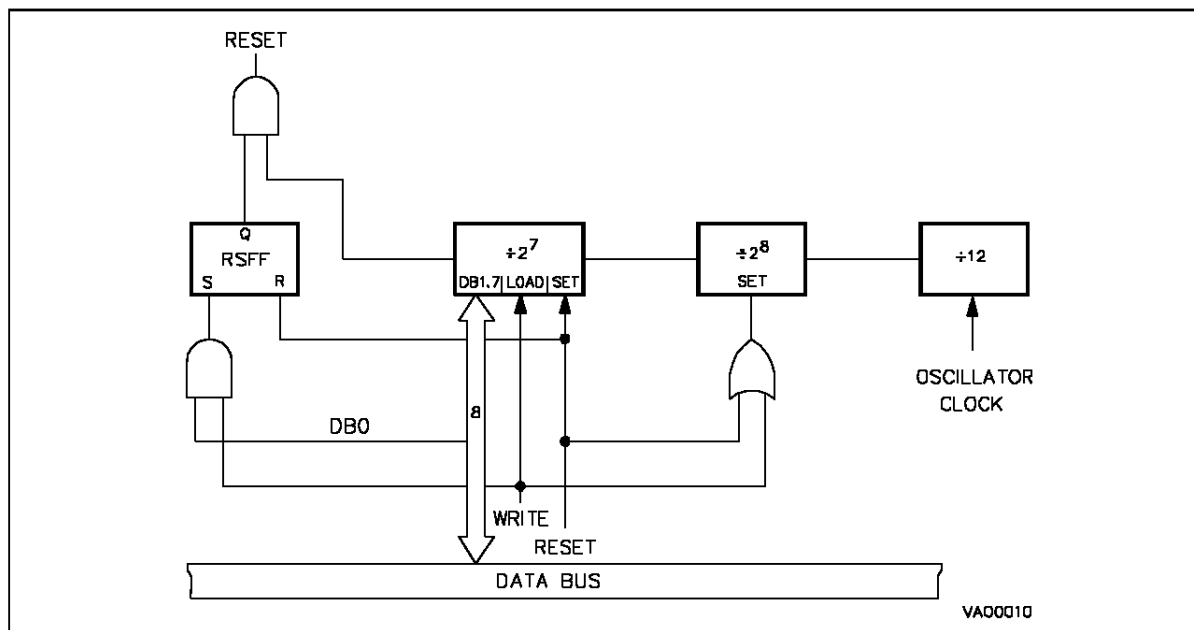
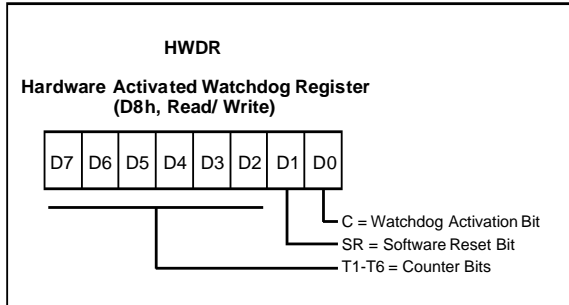

Figure 33. Hardware Activated Watchdog Block Diagram



HARDWARE ACTIVATED DIGITAL WATCHDOG FUNCTION (Continued)

Figure 35. Watchdog Register



T1-T6. These are the watchdog counter bits. It should be noted that D7 (T1) is the LSB of the counter and D2 (T6) is the MSB of the counter, these bits are in the opposite order to normal.

SR. This bit is set to one during the reset phase and will generate a software reset if cleared to zero.

C. This is the watchdog activation bit that is hardware set to one; the user can not change the value of this bit. The watchdog function is always activated independently of changes of value of this bit.

The register reset value is FEh (Bit 1-7 set to one, Bit 0 cleared).

SERIAL PERIPHERAL INTERFACE

The ST631xx Serial Peripheral Interface (SPI) has been designed to be cost effective and flexible in interfacing the various peripherals in TV applications.

It maintains the software flexibility but adds hardware configurations suitable to drive devices which require a fast exchange of data. The three pins dedicated for serial data transfer (single master only) can operate in the following ways:

- as standard I/O lines (software configuration)
- as S-BUS or as I²CBUS (two pins)
- as standard (shift register) SPI

When using the hardware SPI, a fixed clock rate of 62.5kHz is provided.

It has to be noted that the first bit that is output on the data line by the 8-bit shift register is the MSB.

SPI Data/Control Registers

For I/O details on SCL (Serial Clock), SDA (Serial Data) and SEN (Serial Enable) please refer to I/O Ports description with reference to the following registers:

Port B data register, Address C1h (Read/Write).

- BIT D5 "SCL"
- BIT D6 "SDA"
- BIT D7 "SEN"

Port B data direction register, Address C5h (Read/Write).

Figure 36. SPI Serial Data Register

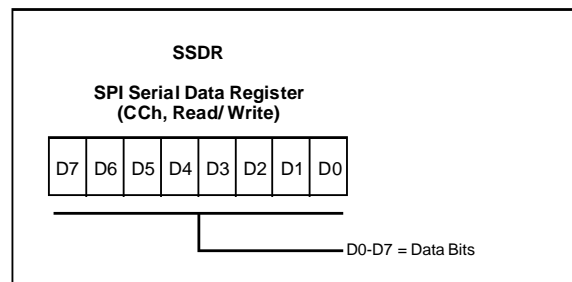

D7-D0. These are the SPI data bits. They can be neither read nor written when SPI is operating (BUSY bit set). They are undefined after reset.

SERIAL PERIPHERAL INTERFACE (Continued)

Figure 37. SPI Control Register 1

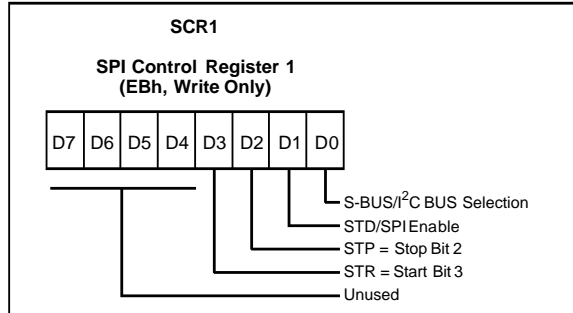

D7-D4. These bits are not used.

STR. This is Start bit for I²CBUS/S-BUS. This bit is meaningless when STD/SPI enable bit is cleared to zero. If this bit is set to one STD/SPI bit is also set to "1" and SPI Start generation, before beginning of transmission, is enabled. Set to zero after reset.

STP. This is Stop bit for I²CBUS/S-BUS. This bit is meaningless when STD/SPI enable bit is cleared to zero. If this bit is set to one STD/SPI bit is also set to "1" and SPI Stop condition generation is enabled. STP bit must be reset when standard protocol is used (this is also the default reset conditions). Set to zero after reset.

STD, SPI Enable. This bit, in conjunction with S-BUS/I²CBUS bit, allows the SPI disable and will select between I²CBUS/S-BUS and Standard shift register protocols. If this bit is set to one, it selects both I²CBUS and S-BUS protocols; final selection between them is made by S-BUS/I²CBUS bit. If this bit is cleared to zero when S-BUS/I²CBUS is set to "1" the Standard shift register protocol is selected. If this bit is cleared to "0" when S-BUS/I²CBUS is cleared to 0 the SPI is disabled. Set to zero after reset.

S-BUS/I²CBUS Selection. This bit, in conjunction with STD/SPI bit, allows the SPI disable and will select between I²CBUS and S-BUS protocols. If this bit is cleared to "0" when STD bit is also "0", the SPI interface is disabled. If this bit is cleared to zero when STD bit is set to "1", the I²CBUS protocol will be selected. If this bit is set to "1" when STD bit is set to "1", the S-BUS protocol will be selected. Cleared to zero after reset.

Table 10. SPI Modes Selection

D1 STD/SP	D0 S-BUS/I ² C BUS	SPI Function
0	0	Disabled
0	1	STD Shift Reg.
1	0	I ² C BUS
1	1	S-BUS

Figure 38. SPI Control Register 2

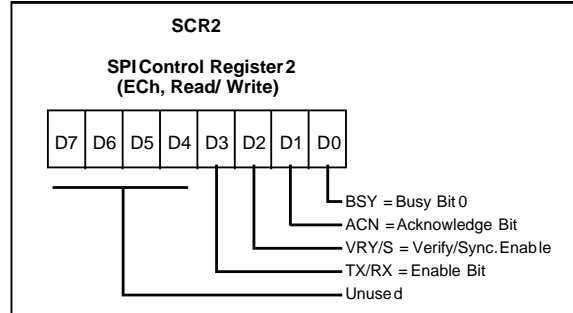

D7-D4. These bits are not used.

TX/RX. Write Only. When this bit is set, current byte operation is a transmission. When it is reset, current operation is a reception. Set to zero after reset.

VRY/S. Read Only/Write Only. This bit has two different functions in relation to read or write operation. Reading Operation: when STD and/or TRX bits is cleared to 0, this bit is meaningless. When bits STD and TX are set to 1, this bit is set each time BSY bit is set. This bit is reset during byte operation if real data on SDA line are different from the output from the shift register. Set to zero after reset. Writing Operation: it enables (if set to one) or disables (if cleared to zero) the interrupt coming from VSYNC pin. Undefined after reset. Refer to OSD description for additional information.

ACN. Read Only. If STD bit (D1 of SCR1 register) is cleared to zero this bit is meaningless. When STD is set to one, this bit is set to one if no Acknowledge has been received. In this case it is automatically reset when BSY is set again. Set to zero after reset.

BSY. Read/Set Only. This is the busy bit. When a one is loaded into this bit the SPI interface start the transmission of the data byte loaded into SDDR data register or receiving and building the receive data into the SDDR data register. This is done in accordance with the protocol, direction and start/stop condition(s). This bit is automatically cleared at the end of the current byte operation. Cleared to zero after reset.

Note :

The SPI shift register is also the data transmission register and the data received register; this feature is made possible by using the serial structure of the ST631xx and thus reducing size and complexity.

SERIAL PERIPHERAL INTERFACE (Continued)

During transmission or reception of data, all access to serial data register is therefore disabled. The reception or transmission of data is started by setting the BUSY bit to "1"; this will be automatically reset at the end of the operation. After reset, the busy bit is cleared to "0", and the hardware SPI disabled by clearing bit 0 and bit 1 of SPI control register 1 to "0". The outputs from the hardware SPI are "ANDed" to the standard I/O software controlled outputs. If the hardware SPI is in operation the Port C pins related to the SPI should be configured as outputs using the Data Direction Register and should be set high. When the SPI is configured as the S-BUS, the three pins PC0, PC1 and PC3 become the pins SCL, SDA and SEN respectively. When configured as the I²CBUS the pins PC0 and PC1 are configured as the pins SCL and SDA; PC3 is not driven and can be used as a general purpose I/O pin. In the case of the STD SPI the pins PC0 and PC1 become the signals CLOCK and DATA, PC3 is not driven and can be used as general purpose I/O pin. The VERIFY bit is available when the SPI is configured as either S-BUS or I²CBUS. At the start of a byte transmission, the verify bit is set to one. If at any time during the transmission of the following eight bits, the data on the SDA line does not match the data forced by the SPI (while SCL is high), then the VERIFY bit is reset. The verify is available only during transmission for the S-BUS and I²CBUS; for other protocol it is not defined. The SDA and SCL signal entering the SPI are buffered in order to remove any minor glitches. When STD bit is set to one (S-BUS or I²CBUS selected), and TRX bit is reset (receiving data), and STOP bit is set (last byte of current communication), the SPI interface does not generate the Acknowledge, according to S-BUS/I²CBUS specifications. PC0-SCL, PC1-SDA and PC3-SEN lines are standard drive I/O port pins with open-drain output configuration (maximum voltage that can be applied to these pins is $V_{DD} + 0.3V$).

S-BUS/I²CBUS Protocol Information

The S-BUS is a three-wire bidirectional data-bus with functional features similar to the I²CBUS. In fact the S-BUS includes decoding of Start/Stop conditions and the arbitration procedure in case of multimaster system configuration (the ST631xx SPI allows a single-master only operation). The SDA line, in the I²CBUS represents the AND combination of SDA and SEN lines in the S-BUS. If the SDA and the SEN lines are short-circuit connected, they appear as the SDA line of the I²CBUS. The Start/Stop conditions are detected (by the external peripherals suited to work with S-BUS/I²CBUS) in the following way:

- On S-BUS by a transition of the SEN line (1 to 0 Start, 0 to 1 Stop) while the SCL line is at high level.
- On I²CBUS by a transition of the SDA line (10 Start, 01 Stop) while the SCL line is at high level.

Start and Stop condition are always generated by the master (ST631xx SPI can only work as single master). The bus is busy after the start condition and can be considered again free only when a certain time delay is left after the stop condition. In the S-BUS configuration the SDA line is only allowed to change during the time SCL line is low. After the start information the SEN line returns to high level and remains unchanged for all the data transmission time. When the transmission is completed the SDA line is set to high level and, at the same time, the SEN line returns to the low level in order to supply the stop information with a low to high transition, while the SCL line is at high level. On the S-BUS, as on the I²CBUS, each eight bit information (byte) is followed by one acknowledged bit which is a high level put on the SDA line by the transmitter. A peripheral that acknowledges has to pull down the SDA line during the acknowledge clock pulse. An addressed receiver has to generate an acknowledge after the reception of each byte; otherwise the SDA line remains at the high level during the ninth clock pulse time. In this case the master transmitter can generate the Stop condition, via the SEN (or SDA in I²CBUS) line, in order to abort the transfer.

SERIAL PERIPHERAL INTERFACE (Continued)

Start/Stop Acknowledge. The timing specs of the S-BUS protocol require that data on the SDA (only on this line for I²C BUS) and SEN lines be stable during the “high” time of SCL. Two exceptions to this rule are foreseen and they are used to signal the start and stop condition of data transfer.

- On S-BUS by a transition of the SEN line (10 Start, 01 Stop) while the SCL line is at high level.
- On I²C BUS by a transition of the SDA line (10 Start, 01 Stop) while the SCL line is at high level.

Data are transmitted in 8-bit groups; after each group, a ninth bit is interposed, with the purpose of acknowledging the transmitting sequence (the transmit device place a “1” on the bus, the acknowledging receiver a “0”).

Interface Protocol. This paragraph deals with the description of data protocol structure. The interface protocol includes:

- A start condition
- A “slave chip address” byte, transmitted by the master, containing two different information:
 - a. the code identifying the device the master wants to address (this information is present in the first seven bits)
 - b. the direction of transmission on the bus (this information is given in the 8th bit of the byte); “0” means “Write”, that is from the master to the slave, while “1” means “Read”. The addressed slave must always acknowledge.

The sequence from, now on, is different according to the value of R/W bit.

1. R/\overline{W} = “0” (\overline{W} rite)

In all the following bytes the master acts as transmitter; the sequence follows with:

- a. an optional data byte to address (if needed) the slave location to be written (it can be a word address in a memory or a register address, etc.).
- b. a “data” byte which will be written at the address given in the previous byte.
- c. further data bytes.
- d. a STOP condition

A data transfer is always terminated by a stop condition generated from the master. The ST631xx peripheral must finish with a stop condition before another start is given. Figure 44 shows an example of write operation.

2. R/\overline{W} = “1” (R)ead

In this case the slave acts as transmitter and, therefore, the transmission direction is changed. In read mode two different conditions can be considered:

- a. The master reads slave immediately after first byte. In this case after the slave address sent from the master with read condition enabled the master transmitter becomes master receiver and the slave receiver becomes slave transmitter.
- b. The master reads a specified register or location of the slave. In this case the first sent byte will contain the slave address with write condition enabled, then the second byte will specify the address of the register to be read. At this moment a new start is given together with the slave address in read mode and the procedure will proceed as described in previous point “a”.

SERIAL PERIPHERAL INTERFACE (Continued)

Figure 39. Master Transmit to Slave Receiver (Write Mode)

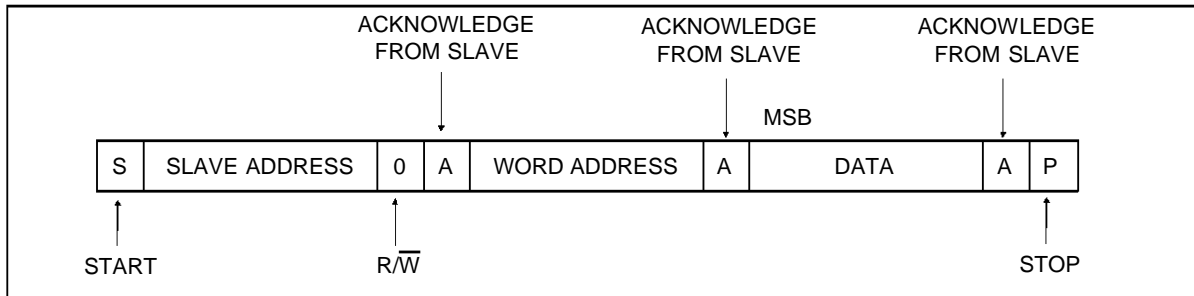

Figure 40. Master Reads Slave Immediately After First Byte (read Mode)

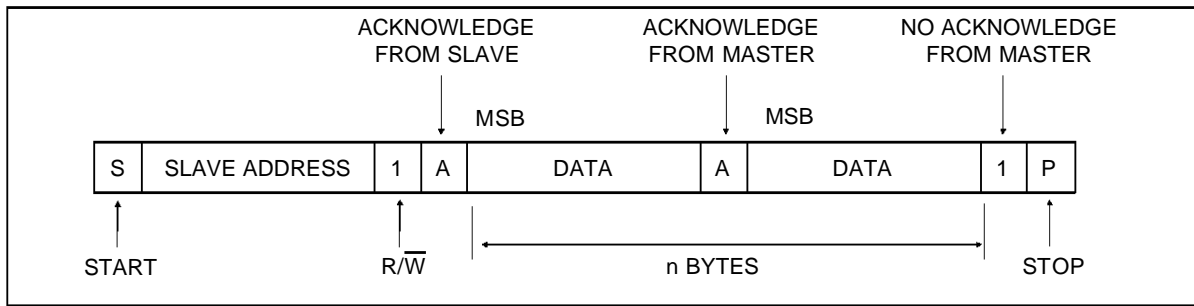
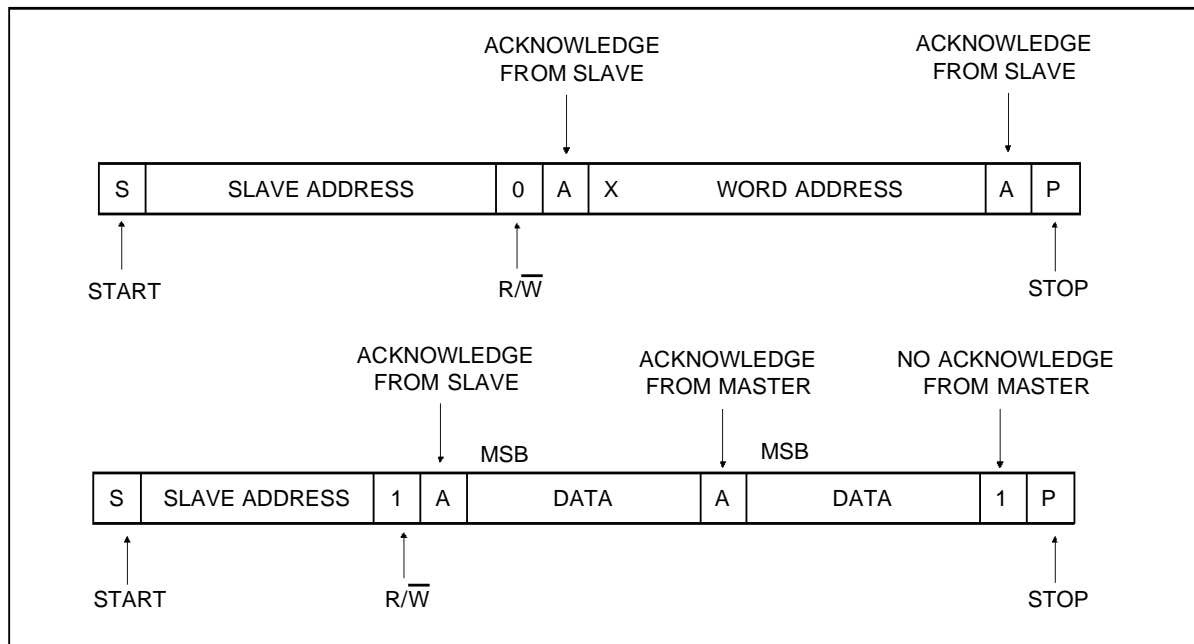

Figure 41. Master Reads After Setting Slave Register Address (Write Address, Read Data)



SERIAL PERIPHERAL INTERFACE (Continued)

S-BUS/²CBUS Timing Diagrams

The clock of the S-BUS/²CBUS of the ST631xx SPI (single master only) has a fixed bus clock frequency of 62.5kHz. All the devices connected to the bus must be able to follow transfers with

frequencies up to 62.5kHz, either by being able to transmit or receive at that speed or by applying the clock synchronization procedure which will force the master into a wait state and stretch low periods.

Figure 42. S-BUS Timing Diagram

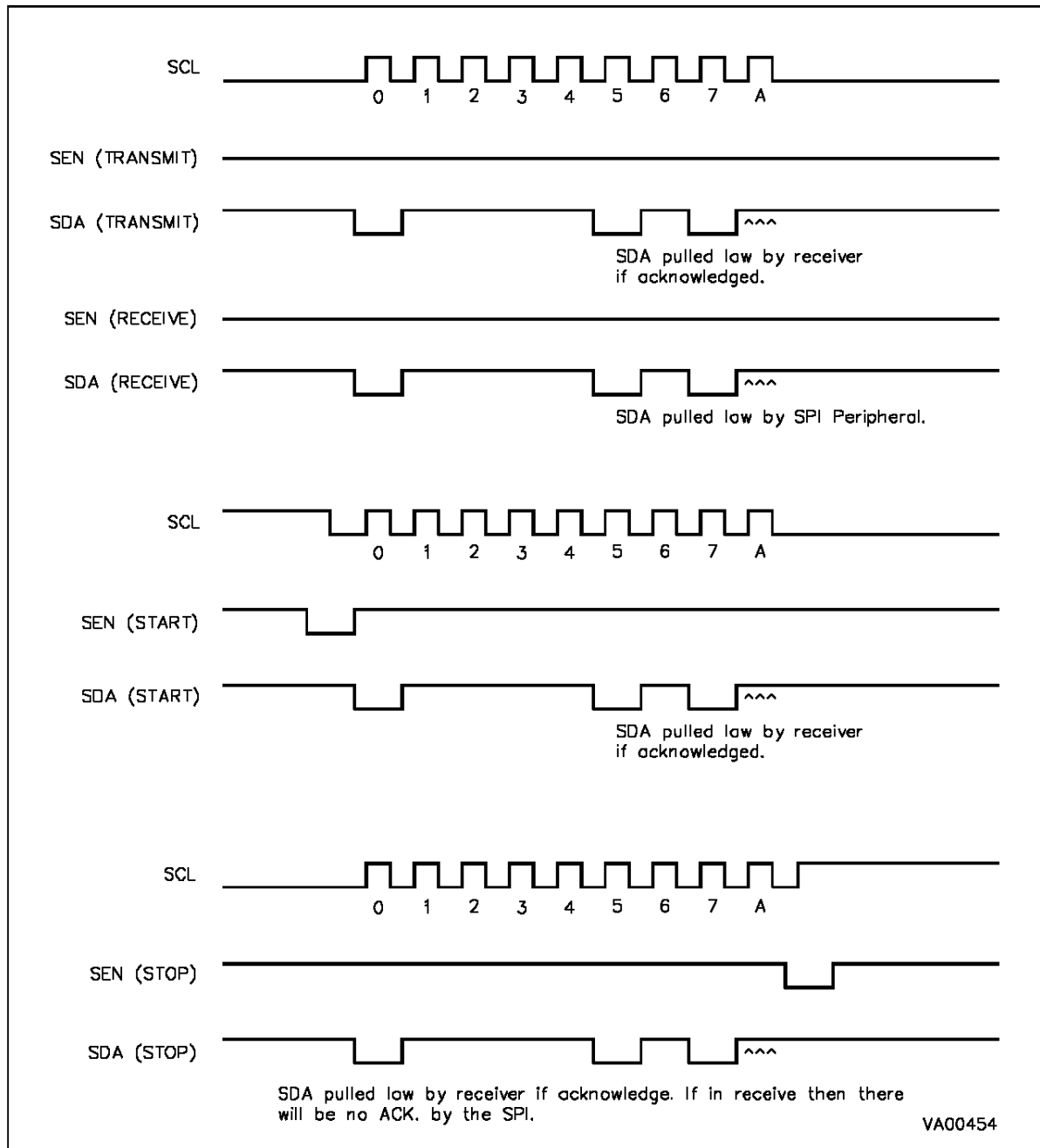

SERIAL PERIPHERAL INTERFACE (Continued)

Figure 43. I²C BUS Timing Diagram

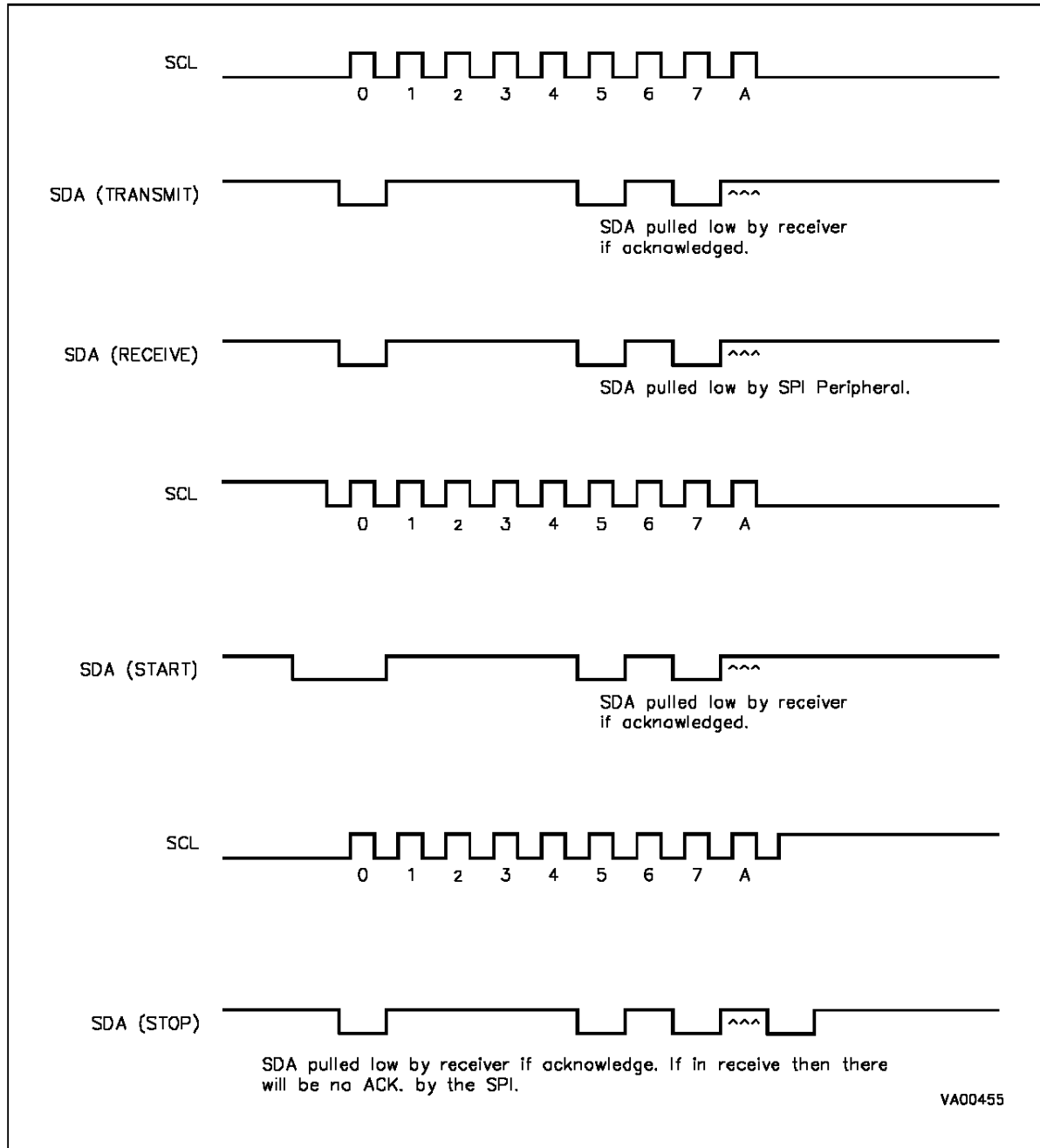

Note: The third pin, SEN, should be high; it is not used in the I²C BUS. Logically SDA is the AND of the S-BUS SDA and SEN.

SERIAL PERIPHERAL INTERFACE (Continued)

Compatibility S-BUS/I²C BUS

Using the S-BUS protocol it is possible to implement mixed system including S-BUS/I²C BUS bus peripherals. In order to have the compatibility with the I²C BUS peripherals, the devices including the S-BUS interface must have their SDA and SEN pins connected together as shown in the following

Figure 44 (a and b). It is also possible to use mixed S-BUS/I²C BUS protocols as shown in Figure 48 (c). S-BUS peripherals will only react to S-BUS protocol signals, while I²C BUS peripherals will only react to I²C BUS signals. Multimaster configuration is not possible with the ST631xx SPI (single master only).

Figure 44. S-BUS/I²C BUS Mixed Configurations

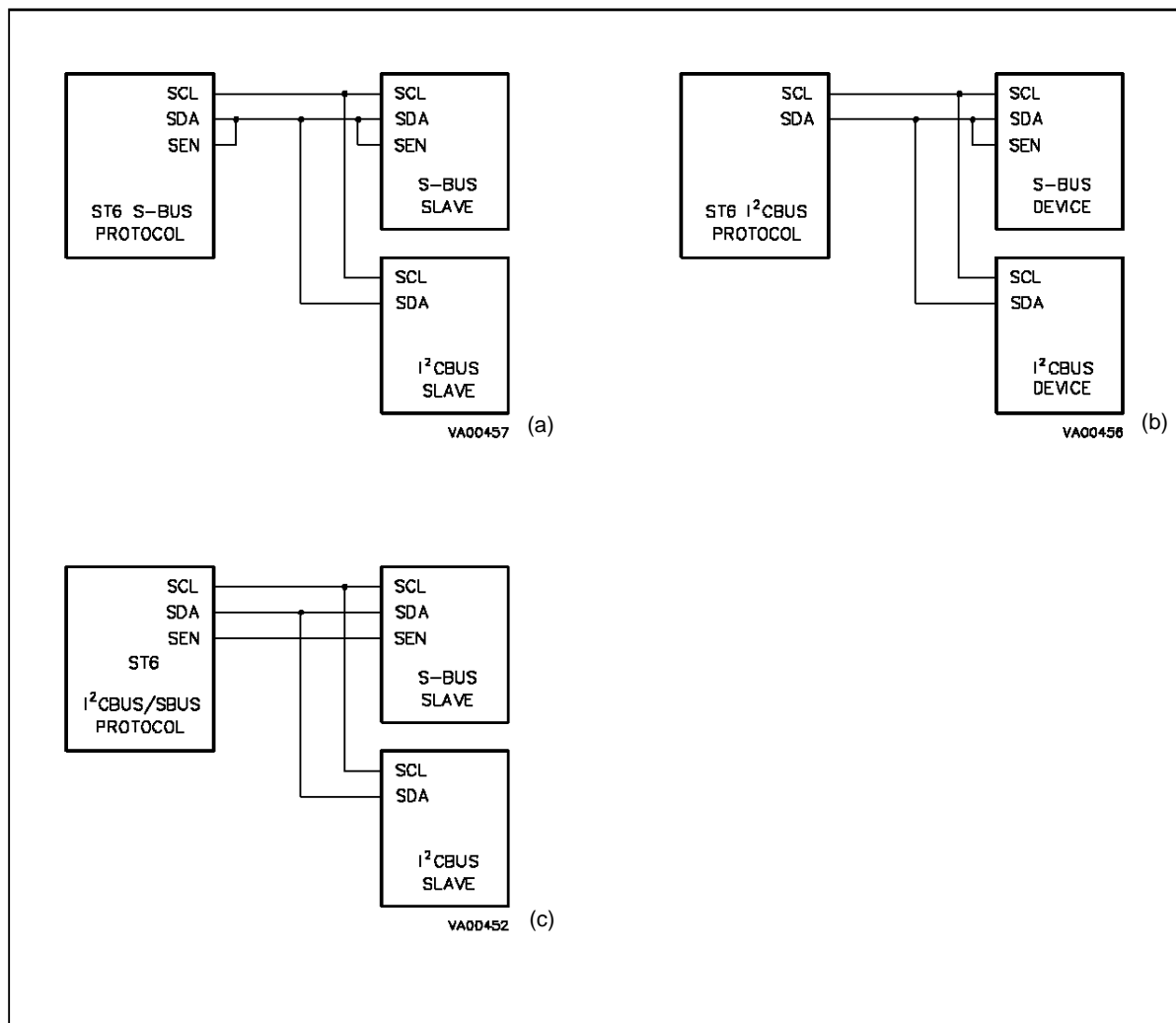

SERIAL PERIPHERAL INTERFACE (Continued)

Figure 45.STD Bus (Hardware Bus Disabled) Timing Diagram

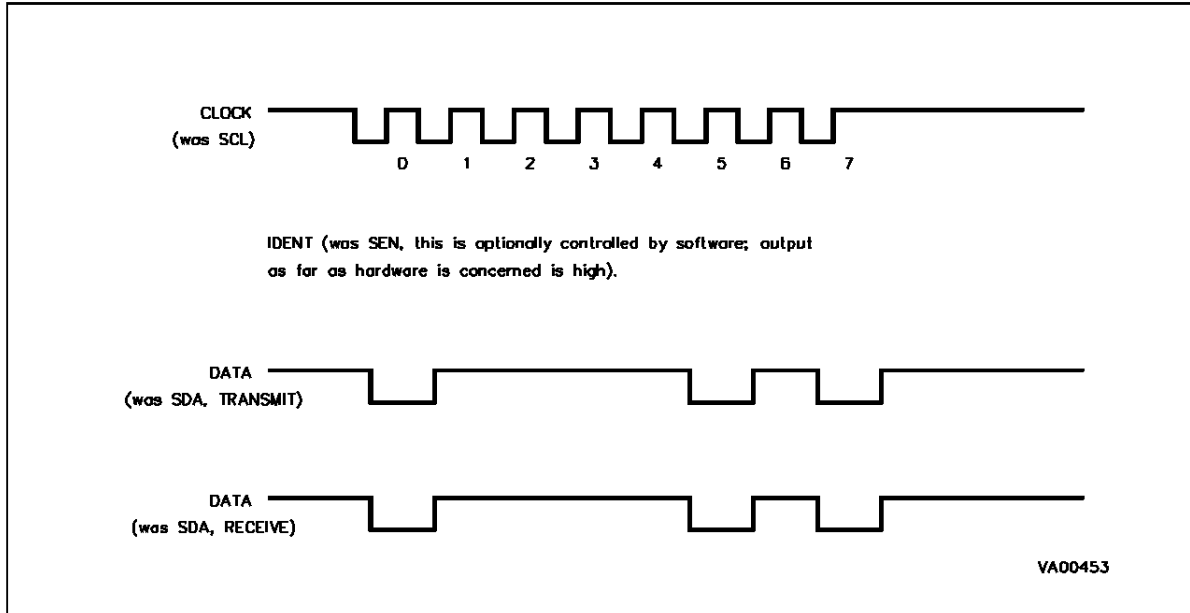
**STD SPI Protocol (Shift Register)**

This protocol is similar to the I^2C BUS with the exception that there is no acknowledge pulse and there are no stop or start bits. The clock cannot be slowed down by the external peripherals.

The I/O ports associated with the SPI should be programmed as outputs with data high in order not to inhibit the functionality of the hardware SPI.

SPI APPLICATION NOTES

Stop Clock Slowdown: In the ST631xx family of devices when operating in the I^2C or SBUS modes, there is no internal clock slowdown for the final STOP clock. Slowdown means that if an external peripheral requires extra time it will hold the ST631xx SCL clock low. To be fully I^2C and SBUS compatible in this respect, the SW should check

that the SCL line is indeed high before proceeding with the START of another I^2C or SBUS transmission. In all other cases the SCL clock slowdown feature is operational.

SPI Standard Bus Protocol: The standard bus protocol is selected by loading the SPI Control Register 1 (SCR1 Add. EBh). Bit 0 named I^2C must be set at one and bit 1 named STD must be reset. When the standard bus protocol is selected bit 2 of the SCR1 is meaningless.

This bit named STOP bit is used only in I^2C BUS or SBUS. However take care that THE STOP BIT MUST BE RESET WHEN THE STANDARD PROTOCOL IS USED. This bit is set to ZERO after RESET.

14-BIT VOLTAGE SYNTHESIS TUNING PERIPHERAL

The ST631xx on-chip voltage synthesis tuning peripheral has been integrated to allow the generation of tuning reference voltage in low/mid end TV set applications. The peripheral is composed of a 14-bit counter that allows the conversion of the digital content in a tuning voltage, available at the VS output pin, by using Pulse Width Modification (PWM), and Bit Rate Multiplier (BRM) techniques. The 14-bit counter gives 16384 steps which allows a resolution of approximately 2mV over a tuning voltage of 32V; this corresponds to a tuning resolution of about 40kHz per step in the UHF band (the actual value will depend on the characteristics of the tuner).

The tuning word consists of a 14-bit word contained in the registers VSDATA1 (location 0EDh) and VSDATA2 (location 0EEh). Coarse tuning (PWM) is performed using the seven MSBits, while fine tuning (BRM) is performed using the data in the seven LSBs. With all zeros loaded the output is zero; as the tuning voltage increases from all zeros, the number of pulses in one period increases to 128 with all pulses being the same width. For values larger than 128, the PWM takes over and the number of pulses in one period remains constant at 128, but the width changes. At the other end of the scale, when almost all ones are loaded, the pulses will start to link together and the number of pulses will decrease. When all ones are loaded, the output will be almost 100% high but will have a low pulse (1/16384 of the high pulse).

Output Details

Inside the on-chip Voltage Synthesis are included the register latches, a reference counter, PWM and BRM control circuitry. In the ST631xx the clock for the 14-bit reference counter is 2MHz derived from the 8MHz system clock. From the circuit point of view, the seven most significant bits control the coarse tuning, while the seven least significant bits control the fine tuning. From the application and software point of view, the 14 bits can be considered as one binary number.

As already mentioned the coarse tuning consists of a PWM signal with 128 steps; we can consider the fine tuning to cover 128 coarse tuning cycles. The addition of pulses is described in the following Table.

Table 11. Fine Tuning Pulse Addition

Fine Tuning (7 LSB)	N° of Pulses added at the following cycles (0...127)
0000001	64
0000010	32, 96
0000100	16, 48, 80, 112
0001000	8, 24,104, 120
0010000	4, 12,116, 124
0100000	2, 6,122, 126
1000000	1, 3,125, 127

The VS output pin has a standard drive push-pull output configuration.

VS Tuning Cell Registers

Figure 46. Voltage Synthesis Data Register 1

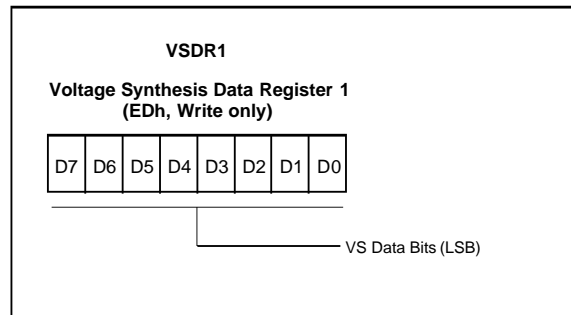

D7-D0. These are the 8 least significant VS data bits. Bit 0 is the LSB. This register is undefined on reset.

Figure 47. Voltage Synthesis Data Register 2

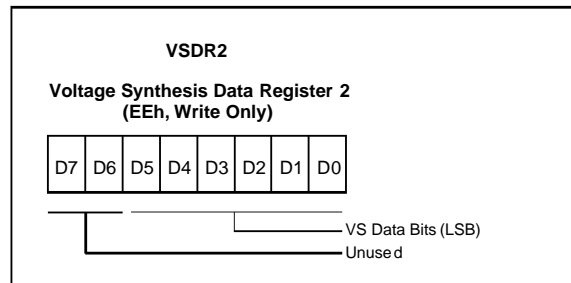

D7-D6. These bits are not used.

D5-D0. These are the 6 most significant VS data bits. Bit 5 is the MSB. This register is undefined on reset.

6-BIT PWM D/A CONVERTER AND 62.5 kHz OUTPUT FUNCTION

The D/A macrocell contains four PWM D/A outputs (31.25kHz repetition, DA0-DA3) with six bit resolution plus a 62.5kHz open-drain output pin (OUT1) specially suited for multistandard chroma processors driving. Both the D/A and OUT1 functions can be disabled by software allowing the DA0-DA3 and OUT1 pins to be used as general purpose open-drain output pins able to withstand signals with up to 12V amplitude.

6-Bit D/A Converters

Each D/A converter of ST631xx is composed by the following main blocks:

- pre-divider
- 6-bit counter
- data latches and compare circuits

The pre-divider uses the clock input frequency (8MHz) and its output clocks the 6-bit free-running counter. The data latched in the four registers (E0h, E1h, E2h and E3h) control the four D/A outputs (DA0,1,2 and 3). When all zeros are loaded the relevant output is an high logic level; all 1's correspond to a pulse with a 1/64 duty cycle and almost 100% zero level. A 7th bit (bit D6) is used to enable the relevant D/A output; when zero, the D/A is no longer enabled and it forces the output to zero. If the other six bits are all zero then the output is controlled only by the enable bit.

The repetition frequency is 32.5kHz and is related to the 8MHz clock frequency. All D/A outputs are open-drain with standard current drive capability and able to withstand up to 12V.

Figure 48. 6-bit PWM D/A & 62.5kHz Output Configuration

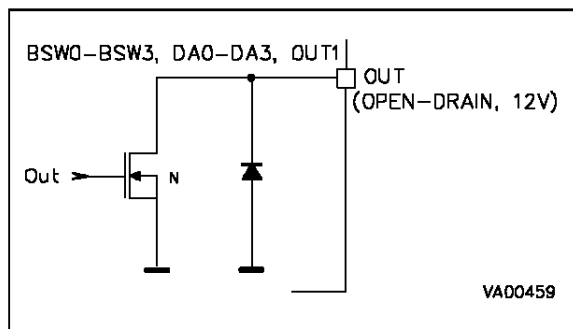

62.5 kHz Output

This pin provides a 62.5 kHz signal with a 50% duty cycle; the output is enabled by a dedicated enable bit (E0h register bit 7). When the 62.5kHz frequency is disabled then the output is controlled by the OUT1 bit and the line can be used as general purpose open-drain output (E1h bit 7). The OUT1 output is open-drain with standard current drive capability and able to withstand signals with up to 12V amplitude.

D/A and OUT1 Data/Control Registers

This paragraph deals with the description of D/A and OUT1 data/control registers. Some bits of DA2 and DA3 data/control registers are used for external interrupt enable and A/D reference voltage shift, please refer to A/D and IR descriptions for additional information.

Figure 49. DA0 Data/Enable Register

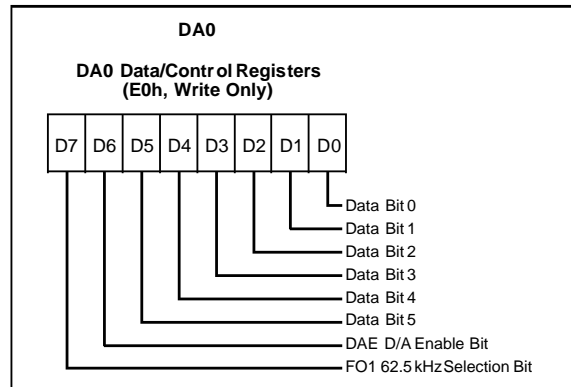

DA0-DA5. These are the 6 bits of the PWM digital to analog converter . Undefined after reset.

DAE. This is the D/A 0 enable bit. If zero, the output of the D/A is forced to zero; if one, the output of the D/A depends on bits DA0..DA5. Undefined after reset.

FO1. This is the 62.5kHz frequency output/ OUT1 selection bit. If one, the OUT1 pin will give a 62.5kHz frequency; if zero the OUT1 pin can be used as general purpose open-drain output and the value present on the pin depends on the value of OUT1 bit programmed in the DA1 data/control register. Undefined after reset.

6-BIT PWM D/A CONVERTERS AND 62.5 kHz OUTPUT FUNCTION (Continued)

Figure 50. DA1 Data/Enable Register

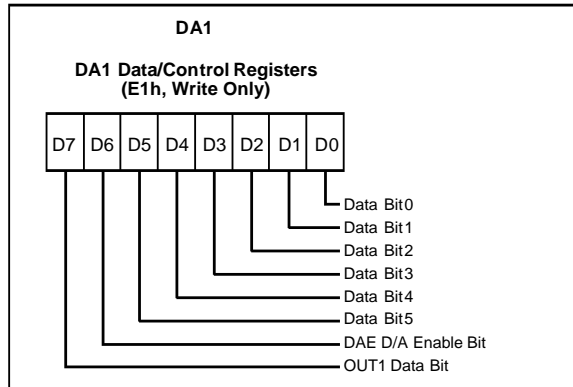

DA0-DA5. These are the 6 bits of the PWM digital to analog converter. Undefined after reset.

DAE. This is the D/A 1 enable bit. If zero, the output of the D/A is forced to zero; if one, the output of the D/A depends on bits DA0..DA5. Undefined after reset.

OUT1. This is the OUT1 data bit. The content of this bit is output on the OUT1 pin when the 62.5kHz frequency function is disabled (FO1 bit in DA0 register is cleared to zero). Undefined after reset.

Figure 51. DA2 Data/Enable Register

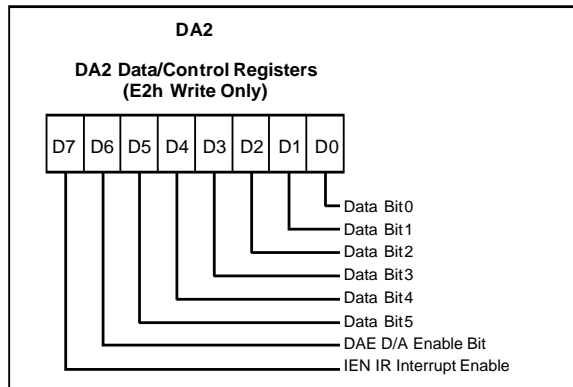

DA0-DA5. These are the 6 bits of the PWM digital to analog converter bits. Undefined after reset.

DAE. This is the D/A 2 enable bit. If zero, the output of the D/A is forced to zero; if one, the output of the D/A depends on bits DA0..DA5. Undefined after reset.

IEN. This is the external interrupt enable. If set to one, the interrupt coming from the external interrupt pin is enabled, if this bit is cleared the interrupt is disabled. Undefined after reset. This interrupt is associated to the NMI interrupt vector. Refer to IR and interrupt descriptions for additional information.

Figure 52. DA3 Data/Enable Register

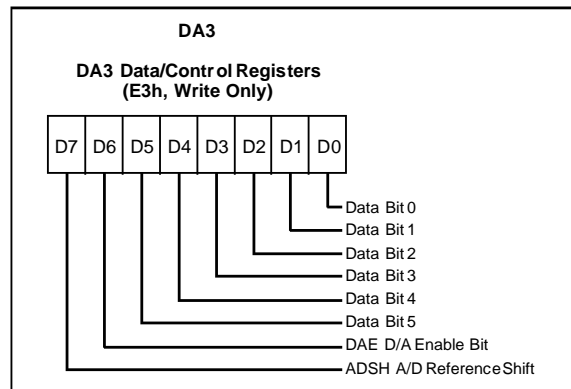

DA0-DA5. These are the 6 bits of the PWM digital to analog converter. Undefined after reset.

DAE. This is the D/A 3 enable bit. If zero, the output of the D/A is forced to zero; if one, the output of the D/A depends on bits DA0..DA5. Undefined after reset.

ADSSH. This is the analog to digital converter reference voltage shift bit. If set to one, the AFC block has reference voltages on 1V border. If set to zero, on 0.5V border. Undefined after reset. Refer to AFC for additional information.

AFC A/D INPUT, KEYBOARD INPUTS AND BANDSWITH OUTPUTS

The AFC macrocell contains an A/D comparator with five levels at intervals of 1V from 1V to 5V. The levels can all be lowered by 0.5V to effectively double the resolution. This A/D can be used to perform the AFC function. In addition this cell offers also a keyboard input register of three bits used to perform a keyboard scan and 4 open-drain outputs (able to withstand signals up to 12V) that can be used to perform band switch function.

Figure 53. AFC, KBY Inputs Configuration Diagrams

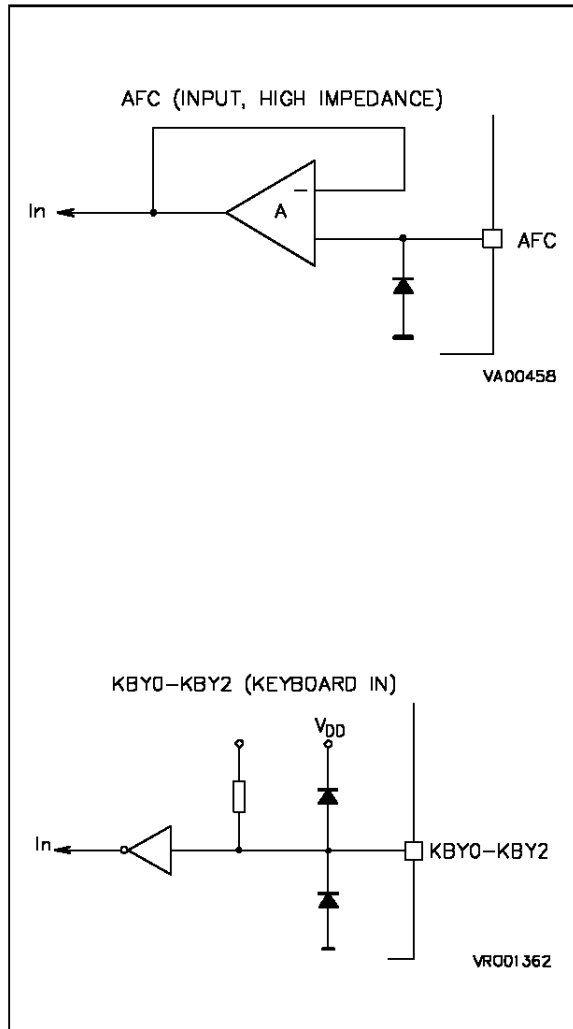
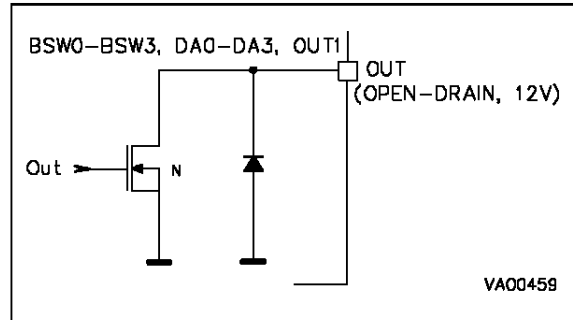

Figure 54. BSW, DA, OUT1 Output Configuration Diagram



A/D Comparator

The A/D used to perform the AFC function (when high threshold is selected) has the following voltage levels: 1,2,3,4 and 5V. Bits 0-2 of AFC result register (E4h address) will provide the result in binary form (less than 1V is 000, greater than 5V is 101).

If the application requires a greater resolution, the sensitivity can be doubled by clearing to zero bit 7 of DA3 Data/Control register, address E3h (refer to D/A description for additional information). In this case all levels are shifted lower by 0.5V. If the two results are now added within a software routine then the A/D S-curve can be located within a resolution of 0.5V. The A/D input has high impedance able to withstand up to 13V signals (input level tolerances $\pm 200\text{mv}$ absolute and $\pm 100\text{mv}$ relative to 5V).

AFC, Keyboard Inputs and Bandswitch Outputs Data/Control Registers

Figure 55. AFC Result Register

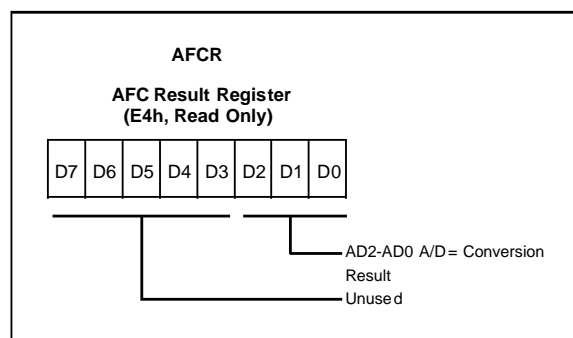

D7-D3. These bits are not used.

AD0-AD2. These bits store the real time conversion of the value present on the AFC input pin. No reset value.

AFC A/D INPUT, KEYBOARD INPUTS AND BANDSWITH OUTPUTS (Continued)

Figure 56. Keyboard Input Register

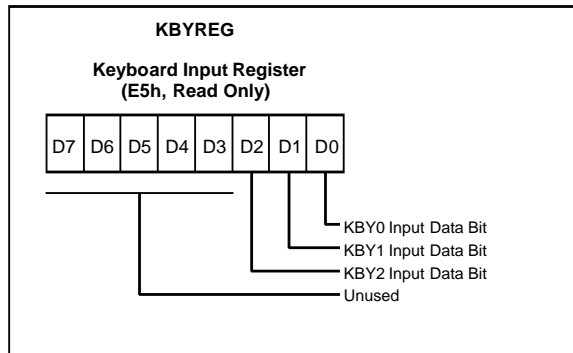

D7-D3. These bits are not used.

KBY0-KBY2. These bits store the logic level present at KBY0, KBY1 and KBY2 input pins. No reset value. This input pins have CMOS levels with on-chip pull-up resistor (100kΩ typical).

Figure 57. Bandswitch Output Register

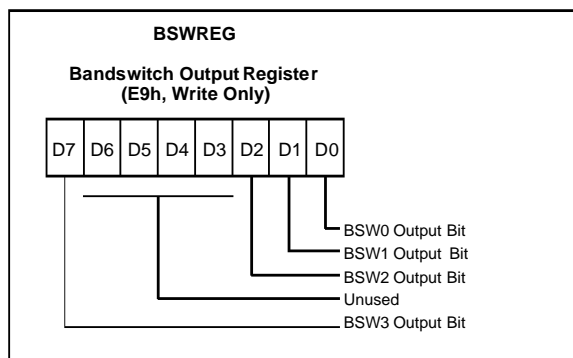

D6-D3. These bits are not used.

BSW0-BSW2,BSW3. The writing into these bits will cause the corresponding BSW open-drain output line to switch to the programmed level. Undefined after reset.

INFRARED INPUT (IRIN)

The IRIN pin is directly connected to the NMI interrupt and acts as external interrupt pin (refer to interrupt description for additional information).

The enable/disable of this interrupt can be managed with the write only IEN bit available in the DA2 Data/Control Register (Address E2h, bit D7). When this bit is set to one the interrupt is enabled otherwise it is disabled.

The IRIN pin is RISING EDGE sensitive.

Application Note

When the IR interrupt is enabled, then a rising edge on the IR pin will generate an interrupt; if the IR interrupt is disabled, no IR interrupts can occur. Care should be taken because if the IR pin is high when the IR interrupt is enabled, an interrupt will also be generated; the following method to eliminate noise can also be used if the SW engineer wishes to enable/disable the IR interrupt.

If a Low-cost infra-red receiver is used, the customer may wish to test the IR signal by software after an interrupt in order to verify that there is a good pulse and not just noise. The IRIN pin cannot be read, so in this case it should be connected in parallel with another pin so the signal can be read. Furthermore the IRIN pin is sensitive to a rising edge interrupt; this means that the input to the pin should be low in the presence of no infra-red signal, but since most infra-red receiver modules give a high signal, the signal will need to be inverted with a transistor.

ON-SCREEN DISPLAY (OSD)

The ST631xx OSD macrocell is a CMOS LSI character generator which enable display of characters and symbols on the TV screen. The character rounding function enhances the readability of the characters. The ST631xx OSD receives horizontal and vertical synchronization signal and outputs screen information via R, G, B and blanking pins. The main characteristics of the macrocell are listed below:

- Number of display characters: 5 lines by 15 columns.
- Number of character types: 128 characters in two banks of 64 characters. **Only one bank per screen can be used.**
- Character size: Four character heights (18h, 36h, 54h, 72h), two heights are available per screen, programmable by line.
- Character format: 6x9 dots with character rounding function.
- Character colour: Eight colours available programmable by word.
- Display position: 64 horizontal positions by $2/f_{osc}$ and 63 vertical positions by 4 h
- Word spacing: 64 positions programmable from $2/f_{osc}$ to $128/f_{osc}$.
- Line spacing: 63 positions programmable from 4 to 252 h.
- Background: No background, square background or fringe background programmable by word.
- Background colour: Two of eight colours available programmable by word.
- Display output: Three character data output terminals (R,G,B) and a blank output terminal.
- Display on/off: Display data may be programmed on or off by word or entire screen. The entire screen may be blanked.

Format Specification

The entire display can be turned on or off through the use of the global enable bit or the display may be selectively turned on or off by word. To turn off the entire display, the global enable bit (GE) should be zero. If the global enable is one, the display is controlled by the word enable bits (WE). The global enable bit is located in the global enable register and the word enable bit is located in the space character preceding the word.

Each line must begin with a format character which describes the format of that line and of the first word. This character is not displayed.

A space character defines the format of subsequent words. A space character is denoted by a one in bit 6 in the display RAM. If bit 6 of the display RAM is a zero, the other six bits define one of the 64 display characters.

The colour, background and enable can be programmed by word. This information is encoded in the space character between words or in the format character at the beginning of each line. Five bits define the colour and background of the following word, and determine whether it will be displayed or not.

Characters are stored in a 6 x 9 dot format. One dot is defined vertically as 2h (horizontal lines) and horizontally as $2/f_{osc}$ if the smallest character size is enabled. There is no space between characters or lines if the vertical space enable (VSE) and horizontal space enable (HSE) bits are both zero. This allows the use of special graphics characters.

The normal alphanumeric character set is formatted to be 5 x 7 with one empty row at the top and one at the bottom and one empty column at the right. If VSE and HSE are both zero, then the spacing between alphanumeric characters is 1 dot and the spacing between lines of alphanumeric characters is 2h.

The character size is programmed by line through the use of the size bit (S) in the format character and the global size bits (GS1 and GS2). The vertical spacing enable bit (VSE) located in the format character controls the spacing between lines. If this bit is set to one, the spacing between lines is defined by the vertical spacing register, otherwise the spacing between lines is 0.

The spacing between words is controlled by the horizontal space enable bit (HSE) located in the space character. If this bit is set to one, the spacing between words is defined by the horizontal spacing register, otherwise the space character width of 6 dots is the spacing between words.

The formats for the display character, space character and format character are described hereafter.

ON-SCREEN DISPLAY (Continued)

“1” -The background on the following word is enabled by BG1 and the colour is set by R1, G1, and B1.

WE. Word Enable. The word enable bit defines whether or not the following word is displayed.

“0” -The word is not displayed.

“1” -If the global enable bit is one, then the word is displayed.

VSE. Vertical Space Enable. The vertical space enable bit determines the spacing between lines.

“0” -The space between lines is equal to 0h. The alphanumeric character set is implemented in a 5 x 7 format with one empty column to the right and one empty row above and one below and stored in a 6 x 9 format.

“1” -The space between lines is defined by the value in the vertical space register.

Table 13. Format Character Register Colour Setting.

R	G	B	Colour
0	0	0	Black
0	0	1	Blue
0	1	0	Green
0	1	1	Cyan
1	0	0	Red
1	0	1	Magenta
1	1	0	Yellow
1	1	1	White

Table 14. Format Character Register Size Setting

GS2	GS1	S	Vertical Height	Horizontal length
0	0	0	18h	6 TDOT
0	0	1	36h	12 TDOT
0	1	0	18h	6 TDOT
0	1	1	54h	18 TDOT
1	0	0	36h	12 TDOT
1	0	1	54h	18 TDOT
1	1	0	36h	12 TDOT
1	1	1	72h	24 TDOT

TDOT= 2/fosc

Figure 60. Display Character Register Explanation

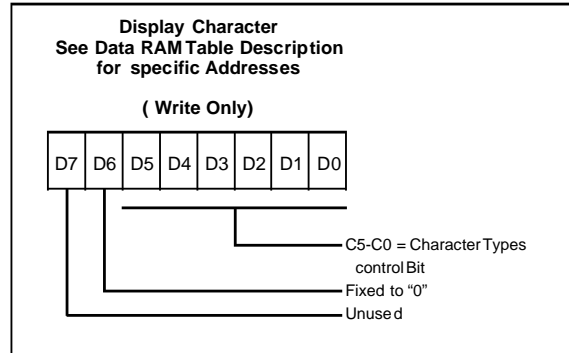

D7. This bit is not used.

D6. This bit is fixed to “0”.

C5-C0. Character type. The 6 character type bits define one of the 64 available character types. These character types are shown on the following pages.

Character Types

The character set is user defined as ROM mask option.

Register and RAM Addressing

The OSD contains seven registers and 80 RAM locations. The seven registers are the Vertical Start Address register, Horizontal Start Address register, Vertical Space register, Horizontal Space register, Background Control register, Global Enable register and Character Bank Select register. The Global Enable register can be written at any time by the ST631xx Core. The other six registers and the RAM can only be read or written to if the global enable is zero.

The six registers and the RAM are located on two pages of the paged memory of the ST631xx MCUs; the Character Bank Select register is located outside the paged memory at address EDh. Each page contains 64 memory locations. This paged memory is at memory locations 00h to 3Fh in the ST631xx memory map. A page of memory is enabled by setting the desired page bit, located in the Data Ram Bank Register, to a one. The page register is location E8h. A one in bit five selects page 5, located on the OSD and a one in bit 6 selects page 6 on the OSD. Table 15 shows the addresses of the OSD registers and RAM.

ON-SCREEN DISPLAY (Continued)

Table 15. OSD Control Registers and Data RAM Addressing

Page	Address	Register or RAM
5	00h - 3Fh	RAM Locations 00h - 3Fh
6	00h - 0Fh	RAM Locations 00h - 0Fh
6	10h	Vertical Start Register
6	11h	Horizontal Start Register
6	12h	Vertical Space Register
6	13h	Horizontal Space Register
6	14h	Background Control Register
6	17h	Global Enable Register
No Page	EDh	Character Bank Select Register

OSD Global Enable Register

This register contains the global enable bit (GE). It is the only register that can be written at any time regardless of the state of the GE bit. It is a write only register.

Figure 61. Global Enable Bit

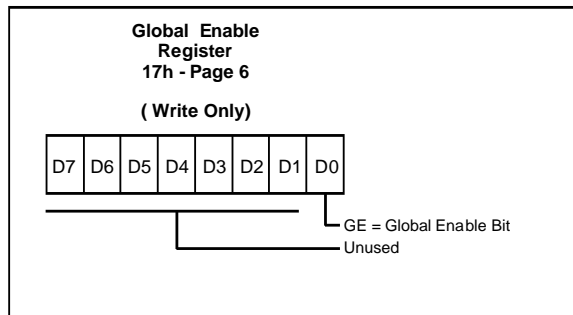

D7-D1. These bits are not used

GE. Global Enable. This bit allows the entire display to be turned off.

“0” - The entire display is disabled. The RAM and other registers of the OSD can be accessed by the Core.

“1” - Display of words is controlled by the word enable bits (WE) located in the format or space character. The other registers and RAM cannot be accessed by the Core.

Figure 62. Vertical Start Address Register

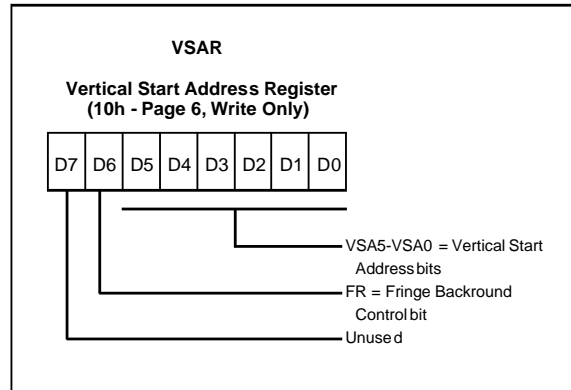

D7. This bit is not used

FR. Fringe Background. This bit changes the background from a box background to a fringe background. The background is enabled by word as defined by either BG0 or BG1.

“0” - The background is defined to be a box which is 7 x 9 dots.

“1” - The background is defined to be a fringe.

VSA5-VSA0. Vertical Start Address. These bits determine the start position of the first line in the vertical direction. The 6 bits can specify 63 display start positions of interval 4h. The first start position will be the fourth line of the display. The vertical start address is defined VSA0 by the following formula.

$$\text{Vertical Start Address} = 4h(2^5(\text{VSA5}) + 2^4(\text{VSA4}) + 2^3(\text{VSA3}) + 2^2(\text{VSA2}) + 2^1(\text{VSA1}) + 2^0(\text{VSA0}))$$

The case of all Vertical Start Address bits being zero is illegal.

ON-SCREEN DISPLAY (Continued)

Figure 63. Horizontal Start Address Register

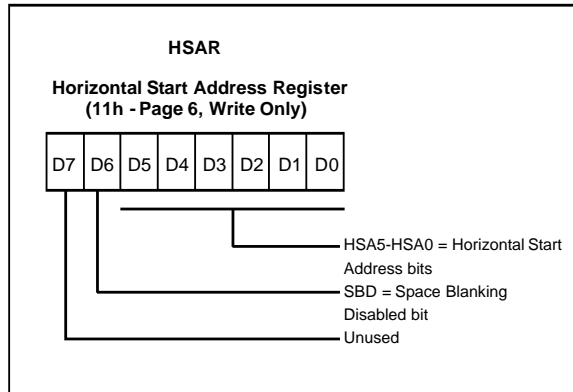

D7. This bit is not used.

SBD. Space Blanking Disable. This bit controls whether or not the background is displayed when outputting spaces. If two background colours are used on adjacent words, then the background should not be displayed on spaces in order to make a nice break between colours. If an even background around an area of text is desired, as in a menu, then the background should be displayed when outputting spaces.

“0” -The background during spaces is controlled by the background enable bits (BG0 and BG1) located in the Background Control register.

“1” -The background is not displayed when outputting spaces.

HSA5, HSA0 - Horizontal Start Address bits. These bits determine the start position of the first character in the horizontal direction. The 6 bits can specify 64 display start positions of interval $2/f_{sc}$ or 400ns. The first start position will be at 4.0µs because of the time needed to access RAM and ROM before the first character can be displayed. The horizontal start address is defined by the following formula.

$$\text{Horizontal Start Address} = 2/f_{osc}(10.0 + 2^5(\text{HSA5}) + 2^4(\text{HSA4}) + 2^3(\text{HSA3}) + 2^2(\text{HSA2}) + 2^1(\text{HSA1}) + 2^0(\text{HSA0}))$$

Figure 64. Vertical Space Register

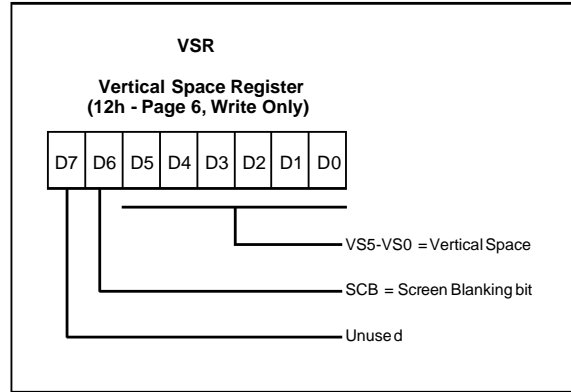

D7. This bit is not used

SCB. Screen Blanking. This bit allows the entire screen to be blanked.

“0” -The blanking output signal (VBLK) is active only when displaying characters.

“1” -The blanking output signal (VBLK) is always active. Characters in the display RAM are still displayed.

When this bit is set to one, the screen is blanked also without setting the Global Enable bit to one (OSD disabled).

VS5, VS0. Vertical Space. These bits determine the spacing between lines if the Vertical Space Enable bit (VSE) in the format character is one. If VSE is zero there will be no spaces between lines. The Vertical Space bits can specify one of 63 spacing values from 4h to 252h. The space between lines is defined by the following formula.

$$\text{Space between lines} = 4h(2^5(\text{VS5}) + 2^4(\text{VS4}) + 2^3(\text{VS3}) + 2^2(\text{VS2}) + 2^1(\text{VS1}) + 2^0(\text{VS0}))$$

The case of all Vertical Start Address bits being zero is illegal.

ON-SCREEN DISPLAY (Continued)

Figure 65. Horizontal Space Register

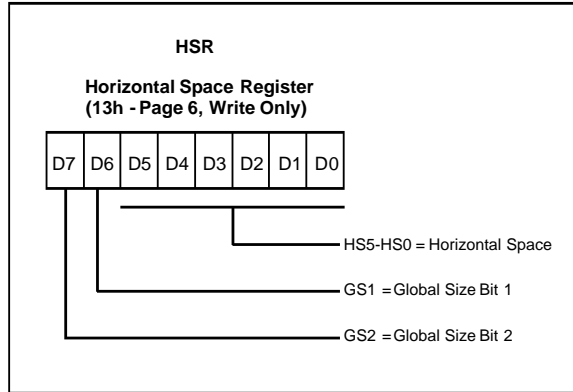

GS2,GS1. Global Size. These bits along with the size bit (S) located in the Character format word specify the character size for each line as defined in Table 16.

Table 16. Horizontal Space Register Size Setting.

GS2	GS1	S	Vertical Height	Horizontal Length
0	0	0	18h	6 TDOT
0	0	1	36h	12 TDOT
0	1	0	18h	6 TDOT
0	1	1	54h	18 TDOT
1	0	0	36h	12 TDOT
1	0	1	54h	18 TDOT
1	1	0	36h	12 TDOT
1	1	1	72h	24 TDOT

Note: TDOT= 2fOSC

HS5, HS0 . Horizontal Space . These bits determine the spacing between words if the Horizontal Space Enable bit (HSE) located in the space character is a one. The space between words is then equal to the width of the space character plus the number of tdots specified by the Horizontal Space bits. The 6 bits can specify one of 64 spacing values ranging from 2/f_{osc} to 128/f_{osc}. The formula is shown below for the smallest size character(18h). If larger size characters are being displayed the spacing between words will increase proportionately. Multiply the value below by 2, 3 or 4 for character sizes of 36h, 54h and 72h respectively.

$$\text{Space between words (not including the space character)} = 2/f_{osc} (1 + 2^5(HS5) + 2^4(HS4) + 2^3(HS3) + 2^2(HS2) + 2^1(HS1) + 2^0(HS0))$$

Background Control Register

This register sets up two possible backgrounds. The background select bit (BGS) in the format or space character will determine which background is selected for the current word.

Figure 66. Background Control Register

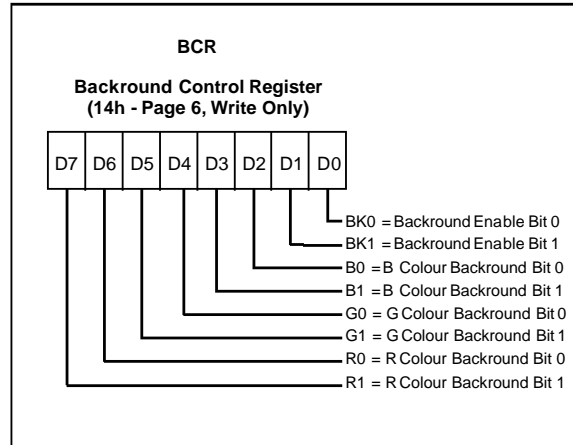

R1,R0,G1,G0,B1,B0. Background Colour. These bits define the colour of the specified background, either background 1 or background 0 as defined in Table 17.

Table 17. Background Register Colour Setting.

RX	GX	BX	Colour
0	0	0	Black
0	0	1	Blue
0	1	0	Green
0	1	1	Cyan
1	0	0	Red
1	0	1	Magenta
1	1	0	Yellow
1	1	1	White

ON-SCREEN DISPLAY (Continued)

Figure 67. Character Bank Select Register

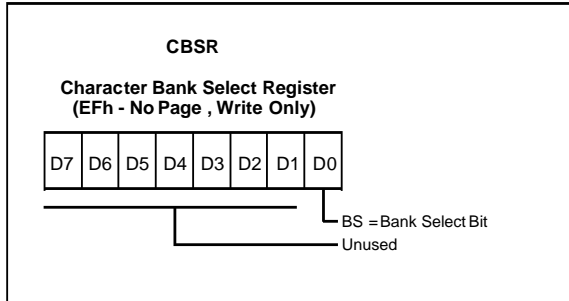

BK1,BK0. Background Enable. These bits determine if the specified background is enabled or not.
 "0" -The following word does not have a background.
 "1" -There is a background around the following word.

D7-D1. These bits are not used

BS. Bank Select. This bit select the character bank to be used. The lower bank is selected with 0. The value can be modified only when the OSD is OFF (GE=0). No reset value.

OSD Data RAM

The contents of the data RAM can be accessed by the ST631xx MCUs only when the global enable bit (GE) in the Global Enable register is a zero.

The first character in every line is the format character. This character is not displayed. It defines the size of the characters in the line and contains the vertical space enable bit. This character also defines the colour, background and display enable for the first word in the line. Subsequent characters are either spaces or one of the 64 available character types.

The space character defines the colour, background, display enable and horizontal space enable for the following word. Since there are 5 display lines of 15 characters each, the display RAM must contain 5 lines x (15 characters + 1 format character) or 80 locations. The RAM size is 80 locations x 7 bits. The data RAM map is shown in Table 12.

ON-SCREEN DISPLAY (Continued)

Table 12. OSD RAM Map

Column	0	1	2	3	4	5	6	7	8	9	10	11	12	13	14	15		
A0	0	1	0	1	0	1	0	1	0	1	0	1	0	1	0	1		
A1	0	0	1	1	0	0	1	1	0	0	1	1	0	0	1	1		
A2	0	0	0	0	1	1	1	1	0	0	0	0	1	1	1	1		
A3	0	0	0	0	0	0	0	0	1	1	1	1	1	1	1	1		
Page	A5	A4	LINE															
5	0	0	1	FT	Ch	Ch	Ch	Ch	Ch	Ch	Ch	Ch	Ch	Ch	Ch	Ch	Ch	
5	0	1	2	FT	Ch	Ch	Ch	Ch	Ch	Ch	Ch	Ch	Ch	Ch	Ch	Ch	Ch	
5	1	0	3	FT	Ch	Ch	Ch	Ch	Ch	Ch	Ch	Ch	Ch	Ch	Ch	Ch	Ch	
5	1	1	4	FT	Ch	Ch	Ch	Ch	Ch	Ch	Ch	Ch	Ch	Ch	Ch	Ch	Ch	
6	0	0	5	FT	Ch	Ch	Ch	Ch	Ch	Ch	Ch	Ch	Ch	Ch	Ch	Ch	Ch	
AVAILABLE SCREEN SPACE																		

Notes: FT. The format character required for each line. Characters in columns 1 thru 15 are displayed.
 Ch. (Byte) Character (Index into OSD character generator) or space character

Emulator Remarks

There are a few differences between emulator and silicon. For noise reasons, the OSD oscillator pins are not available: the internal oscillator cannot be disabled and replaced by an external coil. In the emulator, the Character Bank Select register can be written also with Global Enable bit set, while this is not allowed in the device.

Application Notes

1 - The OSD character generator is composed of a dual port video ram and some circuitry. It needs two input signals VSYNC and HSYNC to synchronize its dedicated oscillator to the TV picture. It generates 4 output signals, that can be used from the TV set to generate the characters on the screen. For instance, they can be used to feed the SCART plug, providing an adequate buffer to drive the low impedance (75 Ω) of the SCART inputs.

2 - The Core sees the OSD as a number of RAM locations (80) plus a certain number of control registers (6). These 86 locations are mapped in two pages of the dynamic data ram address range (0h..3Fh).

In page 5 (load 20h in the register 0E8h), there are 64 bytes of RAM, the ones of the first 4 rows (16 bytes each row, 15 characters per row maximum,

plus an hidden leading format character). In page 6 (load 40h in register 0E8h), the 16 bytes of the fifth row (0..0Fh), and the 6 control registers (10h..14h,17h).

3 - The video RAM is a dual port ram. That means that it can be addressed either from the Core or from the OSD circuitry itself. To reduce the complexity of the circuitry, and thus its cost, some restrictions have been introduced in the use of the OSD.

- a. The Core can Only write to any of the 86 locations (either video RAM or control registers).
- b. The Core can Only write to any of the leading 85 locations when the OSD oscillator is OFF. Only the last location (control register 17h in page 6) can be addressed at any time. This is the Global Enable Register, which contains only the GE bit. If it is set, the OSD is on, if it is reset the OSD is off.

4 - The timing of the on/off switching of the OSD oscillator is the following:

- a. GE bit is set. The OSD oscillator will start on the next VSYNC signal.
- b. GE bit is reset. The OSD oscillator will be immediately switched off.

ON-SCREEN DISPLAY (Continued)

To avoid a bad visual impression, it is important that the GE bit is set before the end of the flyback time when changing characters. This can be done inside the VSYNC interrupt routine. The following diagram can explain better:

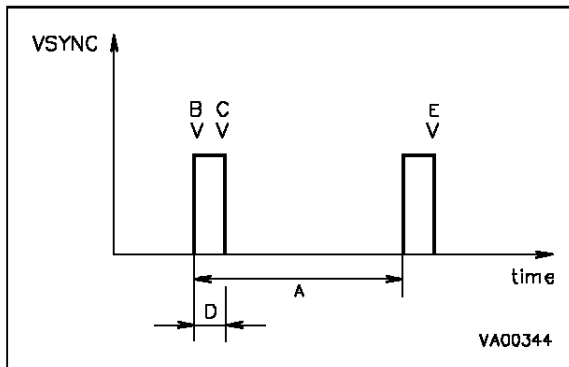
Figure 68. OSD Oscillator ON/OFF Timing

- Notes:**
- A - Picture time: 20 mS in PAL/SECAM.
 - B - VSYNC interrupt, if enabled.
 - C - Starting of OSD oscillator, if GE = 1.
 - D - Flyback time.

When modifying the picture display (i.e.: a bar graph for an analog control), it is important that the switching on of the GE bit is done before the the end of the flyback time (D in Figure 68). If the GE bit is set after the end of the flyback time then the OSD will not start until the beginning of the next frame. This results in one frame being lost and will result in a Flicker on the screen. One method to be sure to avoid the flicker is to wait for the VSYNC interrupt at the start of the flyback; once the VSYNC interrupt is detected, then the GE bit can be set to zero, the characters changed, and the GE set to one. All this should occur before the end of the flyback time in order not to lose a frame. The correct edge of the interrupt must be chosen.

The VSYNC pin may alternatively be sampled by software in order to know the status; this can be done by reading bit 4 of register E4h; this bit is inverted with respect to the VSYNC pin.

6 - An OSD end of line Bar is present in the ST63P1xx piggyback and ST631xx ROM, EPROM and OTP devices when using the background mode. If this bar is present with software running in the piggybacks then it is also present on the ROM mask version. If the end of line bar is seen to be eliminated by software in the piggyback, then it is also be eliminated in the ROM mask version.

The bar appears at the end of the line in the background mode when the last character is a space character, the first format character is defined with S=0 (size 0) and the background is not displayed during the space. The bar is the colour of the background defined by the space character. To eliminate the bar:

- a. If two backgrounds are used then the bar should be moved off the screen by using large word spaces instead of character spaces. If there are not enough spaces before the end of the line, then the location of the valid characters should be moved so they appear at the end of the line (and hence no bar); positioning can be compensated using the horizontal start register.
- b. If only one background is used, then the other background should be transparent in order to eliminate the bar.

7 - The OSD oscillator external network should consist of a capacitor on each of the OSD oscillator pins to ground together with an inductance between pins. The user should select the two capacitors to be the same value (15pF to 25pF each is recommended). The inductance is chosen to give the desired OSD oscillator frequency for the application (typically 56μH).

SOFTWARE DESCRIPTION

The ST631xx software has been designed to fully use the hardware in the most efficient way possible while keeping byte usage to a minimum; in short to provide byte efficient programming capability. The ST631xx Core has the ability to set or clear any register or RAM location bit of the Data space with a single instruction. Furthermore, the program may branch to a selected address depending on the status of any bit of the Data space. The carry bit is stored with the value of the bit when the SET or RES instruction is processed.

Addressing Modes

The ST631xx Core has nine addressing modes which are described in the following paragraphs. The ST631xx Core uses three different address spaces : Program space, Data space, and Stack space. Program space contains the instructions which are to be executed, plus the data for immediate mode instructions. Data space contains the Accumulator, the X,Y,V and W registers, peripheral and Input/Output registers, the RAM locations and Data ROM locations (for storage of tables and constants). Stack space contains six 12-bit RAM cells used to stack the return addresses for subroutines and interrupts.

Immediate. In the immediate addressing mode, the operand of the instruction follows the opcode location. As the operand is a ROM byte, the immediate addressing mode is used to access constants which do not change during program execution (e.g., a constant used to initialize a loop counter).

Direct. In the direct addressing mode, the address of the byte that is processed by the instruction is stored in the location that follows the opcode. Direct addressing allows the user to directly address the 256 bytes in Data Space memory with a single two-byte instruction.

Short Direct. The Core can address the four RAM registers X,Y,V,W (locations 80h, 81h, 82h, 83h) in the short-direct addressing mode. In this case, the instruction is only one byte and the selection of the location to be processed is contained in the opcode. Short direct addressing is a subset of the direct addressing mode. (Note that 80h and 81h are also indirect registers).

Extended. In the extended addressing mode, the 12-bit address needed to define the instruction is obtained by concatenating the four less significant bits of the opcode with the byte following the opcode. The instructions (JP, CALL) that use the extended addressing mode are able to branch to any address of the 4K bytes Program space.

An extended addressing mode instruction is two-byte long.

Program Counter Relative. The relative addressing mode is only used in conditional branch instructions. The instruction is used to perform a test and, if the condition is true, a branch with a span of -15 to +16 locations around the address of the relative instruction. If the condition is not true, the instruction that follows the relative instruction is executed. The relative addressing mode instruction is one-byte long. The opcode is obtained in adding the three most significant bits that characterize the kind of the test, one bit that determines whether the branch is a forward (when it is 0) or backward (when it is 1) branch and the four less significant bits that give the span of the branch (0h to Fh) that must be added or subtracted to the address of the relative instruction to obtain the address of the branch.

Bit Direct. In the bit direct addressing mode, the bit to be set or cleared is part of the opcode, and the byte following the opcode points to the address of the byte in which the specified bit must be set or cleared. Thus, any bit in the 256 locations of Data space memory can be set or cleared.

Bit Test & Branch. The bit test and branch addressing mode is a combination of direct addressing and relative addressing. The bit test and branch instruction is three-byte long. The bit identification and the tested condition are included in the opcode byte. The address of the byte to be tested follows immediately the opcode in the Program space. The third byte is the jump displacement, which is in the range of -126 to +129. This displacement can be determined using a label, which is converted by the assembler.

Indirect. In the indirect addressing mode, the byte processed by the register-indirect instruction is at the address pointed by the content of one of the indirect registers, X or Y (80h,81h). The indirect register is selected by the bit 4 of the opcode. A register indirect instruction is one byte long.

Inherent. In the inherent addressing mode, all the information necessary to execute the instruction is contained in the opcode. These instructions are one byte long.

SOFTWARE DESCRIPTION (Continued)**Instruction Set**

The ST631xx Core has a set of 40 basic instructions. When these instructions are combined with nine addressing modes, 244 usable opcodes can be obtained. They can be divided into six different types: load/store, arithmetic/logic, conditional branch, control instructions, jump/call, bit manipulation. The following paragraphs describe the different types.

All the instructions within a given type are presented in individual tables.

Load & Store. These instructions use one, two or three bytes in relation with the addressing mode. One operand is the Accumulator for LOAD and the other operand is obtained from data memory using one of the addressing modes.

For Load Immediate one operand can be any of the 256 data space bytes while the other is always immediate data. See Table 13.

Table 13. Load & Store Instructions

Instruction	Addressing Mode	Bytes	Cycles	Flags	
				Z	C
LD A, X	Short Direct	1	4	Δ	*
LD A, Y	Short Direct	1	4	Δ	*
LD A, V	Short Direct	1	4	Δ	*
LD A, W	Short Direct	1	4	Δ	*
LD X, A	Short Direct	1	4	Δ	*
LD Y, A	Short Direct	1	4	Δ	*
LD V, A	Short Direct	1	4	Δ	*
LD W, A	Short Direct	1	4	Δ	*
LD A, rr	Direct	2	4	Δ	*
LD rr, A	Direct	2	4	Δ	*
LD A, (X)	Indirect	1	4	Δ	*
LD A, (Y)	Indirect	1	4	Δ	*
LD (X), A	Indirect	1	4	Δ	*
LD (Y), A	Indirect	1	4	Δ	*
LDI A, #N	Immediate	2	4	Δ	*
LDI rr, #N	Immediate	3	4	*	*

Notes:

X, Y. Indirect Register Pointers, V & W Short Direct Registers

. Immediate data (stored in ROM memory)

rr. Data space register

Δ. Affected

* . Not Affected

SOFTWARE DESCRIPTION (Continued)

Arithmetic and Logic. These instructions are used to perform the arithmetic calculations and logic operations. In AND, ADD, CP, SUB instructions one operand is always the accumulator while the other can be either a data space memory

content or an immediate value in relation with the addressing mode. In CLR, DEC, INC instructions the operand can be any of the 256 data space addresses. In COM, RLC, SLA the operand is always the accumulator. See Table 14.

Table 14. Arithmetic & Logic Instructions

Instruction	Addressing Mode	Bytes	Cycles	Flags	
				Z	C
ADD A, (X)	Indirect	1	4	Δ	Δ
ADD A, (Y)	Indirect	1	4	Δ	Δ
ADD A, rr	Direct	2	4	Δ	Δ
ADDI A, #N	Immediate	2	4	Δ	Δ
AND A, (X)	Indirect	1	4	Δ	*
AND A, (Y)	Indirect	1	4	Δ	*
AND A, rr	Direct	2	4	Δ	*
ANDI A, #N	Immediate	2	4	Δ	*
CLR A	Short Direct	2	4	Δ	Δ
CLR rr	Direct	3	4	*	*
COM A	Inherent	1	4	Δ	Δ
CP A, (X)	Indirect	1	4	Δ	Δ
CP A, (Y)	Indirect	1	4	Δ	Δ
CP A, rr	Direct	2	4	Δ	Δ
CPI A, #N	Immediate	2	4	Δ	Δ
DEC X	Short Direct	1	4	Δ	*
DEC Y	Short Direct	1	4	Δ	*
DEC V	Short Direct	1	4	Δ	*
DEC W	Short Direct	1	4	Δ	*
DEC A	Direct	2	4	Δ	*
DEC rr	Direct	2	4	Δ	*
DEC (X)	Indirect	1	4	Δ	*
DEC (Y)	Indirect	1	4	Δ	*
INC X	Short Direct	1	4	Δ	*
INC Y	Short Direct	1	4	Δ	*
INC V	Short Direct	1	4	Δ	*
INC W	Short Direct	1	4	Δ	*
INC A	Direct	2	4	Δ	*
INC rr	Direct	2	4	Δ	*
INC (X)	Indirect	1	4	Δ	*
INC (Y)	Indirect	1	4	Δ	*
RLC A	Inherent	1	4	Δ	Δ
SLA A	Inherent	2	4	Δ	Δ
SUB A, (X)	Indirect	1	4	Δ	Δ
SUB A, (Y)	Indirect	1	4	Δ	Δ
SUB A, rr	Direct	2	4	Δ	Δ
SUBI A, #N	Immediate	2	4	Δ	Δ

Notes:

X,Y. Indirect Register Pointers, V & W Short Direct Registers

Δ. Affected

#. Immediate data (stored in ROM memory)

*. Not Affected

rr. Data space register

SOFTWARE DESCRIPTION (Continued)

Conditional Branch. The branch instructions achieve a branch in the program when the selected condition is met. See Table 15.

Bit Manipulation Instructions. These instructions can handle any bit in data space memory. One group either sets or clears. The other group (see Conditional Branch) performs the bit test branch operations. See Table 16.

Control Instructions. The control instructions control the MCU operations during program execution. See Table 17.

Jump and Call. These two instructions are used to perform long (12-bit) jumps or subroutines call inside the whole program space. Refer to Table 18.

Table 15. Conditional Branch Instructions

Instruction	Branch If	Bytes	Cycles	Flags	
				Z	C
JRC e	C = 1	1	2	*	*
JRNC e	C = 0	1	2	*	*
JRZ e	Z = 1	1	2	*	*
JRNZ e	Z = 0	1	2	*	*
JRR b, rr, ee	Bit = 0	3	5	*	Δ
JRS b, rr, ee	Bit = 1	3	5	*	Δ

Notes:

b. 3-bit address
e. 5 bit signed displacement in the range -15 to +16
ee. 8 bit signed displacement in the range -126 to +129

rr. Data space register
Δ . Affected
* . Not Affected

Table 16. Bit Manipulation Instructions

Instruction	Addressing Mode	Bytes	Cycles	Flags	
				Z	C
SET b,rr	Bit Direct	2	4	*	*
RES b,rr	Bit Direct	2	4	*	*

Notes:

b. 3-bit address;
rr. Data space register;

* . Not Affected

Table 17. Control Instructions

Instruction	Addressing Mode	Bytes	Cycles	Flags	
				Z	C
NOP	Inherent	1	2	*	*
RET	Inherent	1	2	*	*
RETI	Inherent	1	2	Δ	Δ
STOP (1)	Inherent	1	2	*	*
WAIT	Inherent	1	2	*	*

Notes:

1. This instruction is deactivated and a WAIT is automatically executed instead of a STOP if the hardware watchdog function is selected.

Δ . Affected
* . Not Affected

Table 18. Jump & Call Instructions

Instruction	Addressing Mode	Bytes	Cycles	Flags	
				Z	C
CALL abc	Extended	2	4	*	*
JP abc	Extended	2	4	*	*

Notes:

abc.12-bit address;
* . Not Affected

SOFTWARE DESCRIPTION (Continued)

Opcode Map Summary. The following table contains an opcode map for the instructions used on the MCU.

Low Hi	0 0000	1 0001	2 0010	3 0011	4 0100	5 0101	6 0110	7 0111	8 1000	9 1001	A 1010	B 1011	C 1100	D 1101	E 1110	F 1111	Low Hi
0 0000	2 JRNZ e 1 pcr	4 CALL abc 2 ext	2 JRNC e 1 pcr	5 JRR b0,rr,ee 3	2 JRZ e 1 pcr	#	2 JRC e 1 prc	4 LD a,(x) 1 ind	2 JRNZ e 1 pcr	4 JP abc 2 ext	2 JRNC e 1 pcr	4 RES b0,rr 2 b.d	2 JRZ e 1 pcr	4 LDI rr,nn 3 imm	2 JRC e 1 pcr	4 LD a,(y) 1 ind	0 0000
1 0001	2 JRNZ e 1 pcr	4 CALL abc 2 ext	2 JRNC e 1 pcr	5 JRS b0,rr,ee 3 bt	2 JRZ e 1 pcr	x	2 JRC e 1 prc	4 LDI a,nn 2 imm	2 JRNZ e 1 pcr	4 JP abc 2 ext	2 JRNC e 1 pcr	4 SET b0,rr 2 b.d	2 JRZ e 1 pcr	4 DEC x 1 sd	2 JRC e 1 pcr	4 LD a,rr 2 dir	1 0001
2 0010	2 JRNZ e 1 pcr	4 CALL abc 2 ext	2 JRNC e 1 pcr	5 JRR b4,rr,ee 3 bt	2 JRZ e 1 pcr	#	2 JRC e 1 prc	4 CP a,(x) 1 ind	2 JRNZ e 1 pcr	4 JP abc 2 ext	2 JRNC e 1 pcr	4 RES b4,rr 2 b.d	2 JRZ e 1 pcr	4 COM inh 1 inh	2 JRC e 1 pcr	4 CP e 1 ind	2 0010
3 0011	2 JRNZ e 1 pcr	4 CALL abc 2 ext	2 JRNC e 1 pcr	5 JRS b4,rr,ee 3 bt	2 JRZ e 1 pcr	a,x	2 JRC e 1 prc	4 CPI a,nn 2 imm	2 JRNZ e 1 pcr	4 JP abc 2 ext	2 JRNC e 1 pcr	4 SET b4,rr 2 b.d	2 JRZ e 1 pcr	4 LD x,a 1 sd	2 JRC e 1 pcr	4 CP a,rr 2 dir	3 0011
4 0100	2 JRNZ e 1 pcr	4 CALL abc 2 ext	2 JRNC e 1 pcr	5 JRR b2,rr,ee 3 bt	2 JRZ e 1 pcr	#	2 JRC e 1 prc	4 ADD a,(x) 1 ind	2 JRNZ e 1 pcr	4 JP abc 2 ext	2 JRNC e 1 pcr	4 RES b2,rr 2 b.d	2 JRZ e 1 pcr	2 RETI inh 1 inh	2 JRC e 1 pcr	4 ADD a,(y) 1 ind	4 0100
5 0101	2 JRNZ e 1 pcr	4 CALL abc 2 ext	2 JRNC e 1 pcr	5 JRS b2,rr,ee 3 bt	2 JRZ e 1 pcr	y	2 JRC e 1 prc	4 ADDI a,nn 2 imm	2 JRNZ e 1 pcr	4 JP abc 2 ext	2 JRNC e 1 pcr	4 SET b2,rr 2 b.d	2 JRZ e 1 pcr	4 DEC y 1 sd	2 JRC e 1 pcr	4 ADD a,rr 2 dir	5 0101
6 0110	2 JRNZ e 1 pcr	4 CALL abc 2 ext	2 JRNC e 1 pcr	5 JRR b6,rr,ee 3 bt	2 JRZ e 1 pcr	#	2 JRC e 1 prc	4 INC (x) 1 ind	2 JRNZ e 1 pcr	4 JP abc 2 ext	2 JRNC e 1 pcr	4 RES b6,rr 2 b.d	2 JRZ e 1 pcr	2 STOP inh 1 inh	2 JRC e 1 pcr	4 LD (y) 1 ind	6 0110
7 0111	2 JRNZ e 1 pcr	4 CALL abc 2 ext	2 JRNC e 1 pcr	5 JRS b6,rr,ee 3 bt	2 JRZ e 1 pcr	a,y	2 JRC e 1 prc	#	2 JRNZ e 1 pcr	4 JP abc 2 ext	2 JRNC e 1 pcr	4 SET b6,rr 2 b.d	2 JRZ e 1 pcr	4 LD y,a 1 sd	2 JRC e 1 pcr	4 INC rr 2 dir	7 0111
8 1000	2 JRNZ e 1 pcr	4 CALL abc 2 ext	2 JRNC e 1 pcr	5 JRR b1,rr,ee 3 bt	2 JRZ e 1 pcr	#	2 JRC e 1 prc	4 LD (x),a 1 ind	2 JRNZ e 1 pcr	4 JP abc 2 ext	2 JRNC e 1 pcr	4 RES b1,rr 2 b.d	2 JRZ e 1 pcr	#	2 JRC e 1 pcr	4 LD (y),a 1 ind	8 1000
9 1001	2 JRNZ e 1 pcr	4 CALL abc 2 ext	2 JRNC e 1 pcr	5 JRS b1,rr,ee 3 bt	2 JRZ e 1 pcr	v	2 JRC e 1 prc	#	2 JRNZ e 1 pcr	4 JP abc 2 ext	2 JRNC e 1 pcr	4 SET b1,rr 2 b.d	2 JRZ e 1 pcr	4 DEC v 1 sd	2 JRC e 1 pcr	4 LD rr,a 2 dir	9 1001
A 1010	2 JRNZ e 1 pcr	4 CALL abc 2 ext	2 JRNC e 1 pcr	5 JRR b5,rr,ee 3 bt	2 JRZ e 1 pcr	#	2 JRC e 1 prc	4 AND a,(x) 1 ind	2 JRNZ e 1 pcr	4 JP abc 2 ext	2 JRNC e 1 pcr	4 RES b5,rr 2 b.d	2 JRZ e 1 pcr	4 RLC a 1 inh	2 JRC e 1 pcr	4 AND a,(y) 1 ind	A 1010
B 1011	2 JRNZ e 1 pcr	4 CALL abc 2 ext	2 JRNC e 1 pcr	5 JRS b5,rr,ee 3 bt	2 JRZ e 1 pcr	a,v	2 JRC e 1 prc	4 ANDI a,nn 2 imm	2 JRNZ e 1 pcr	4 JP abc 2 ext	2 JRNC e 1 pcr	4 SET b5,rr 2 b.d	2 JRZ e 1 pcr	4 LD v,a 1 sd	2 JRC e 1 pcr	4 AND a,rr 2 dir	B 1011
C 1100	2 JRNZ e 1 pcr	4 CALL abc 2 ext	2 JRNC e 1 pcr	5 JRR b3,rr,ee 3 bt	2 JRZ e 1 pcr	#	2 JRC e 1 prc	4 SUB a,(x) 1 ind	2 JRNZ e 1 pcr	4 JP abc 2 ext	2 JRNC e 1 pcr	4 RES b3,rr 2 b.d	2 JRZ e 1 pcr	2 RET inh 1 inh	2 JRC e 1 pcr	4 SUB a,(y) 1 ind	C 1100
D 1101	2 JRNZ e 1 pcr	4 CALL abc 2 ext	2 JRNC e 1 pcr	5 JRS b3,rr,ee 3 bt	2 JRZ e 1 pcr	w	2 JRC e 1 prc	4 SUBI a,nn 2 imm	2 JRNZ e 1 pcr	4 JP abc 2 ext	2 JRNC e 1 pcr	4 SET b3,rr 2 b.d	2 JRZ e 1 pcr	4 DEC w 1 sd	2 JRC e 1 pcr	4 SUB a,rr 2 dir	D 1101
E 1110	2 JRNZ e 1 pcr	4 CALL abc 2 ext	2 JRNC e 1 pcr	5 JRR b7,rr,ee 3 bt	2 JRZ e 1 pcr	#	2 JRC e 1 prc	4 DEC (x) 1 ind	2 JRNZ e 1 pcr	4 JP abc 2 ext	2 JRNC e 1 pcr	4 RES b7,rr 2 b.d	2 JRZ e 1 pcr	2 WAIT inh 1 inh	2 JRC e 1 pcr	4 DEC (y) 1 ind	E 1110
F 1111	2 JRNZ e 1 pcr	4 CALL abc 2 ext	2 JRNC e 1 pcr	5 JRS b7,rr,ee 3 bt	2 JRZ e 1 pcr	a,w	2 JRC e 1 prc	#	2 JRNZ e 1 pcr	4 JP abc 2 ext	2 JRNC e 1 pcr	4 SET b7,rr 2 b.d	2 JRZ e 1 pcr	4 LD w,a 1 sd	2 JRC e 1 pcr	4 DEC rr 2 dir	F 1111

Abbreviations for Addressing Modes:

- dir Direct
- sd Short Direct
- imm Immediate
- inh Inherent
- ext Extended
- b.d Bit Direct
- bt Bit Test
- pcr Program Counter Relative
- ind Indirect

Legend:

- # Indicates Illegal Instructions
- e 5 Bit Displacement
- b 3 Bit Address
- rr1byte dataspace address
- nn 1 byte immediate data
- abc 12 bit address
- ee 8 bit Displacement

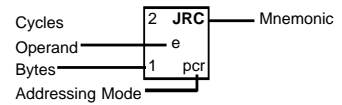

ABSOLUTE MAXIMUM RATINGS

This product contains devices to protect the inputs against damage due to high static voltages, however it is advised to take normal precaution to avoid application of any voltage higher than maximum rated voltages.

For proper operation it is recommended that V_I and V_O must be higher than V_{SS} and smaller than V_{DD} . Reliability is enhanced if unused inputs are connected to an appropriated logic voltage level (V_{DD} or V_{SS}).

Power Considerations. The average chip-junction temperature, T_j , in Celsius can be obtained from :

$$T_j = T_A + PD \times R_{thJA}$$

Where : T_A = Ambient Temperature.

R_{thJA} = Package thermal resistance (junction-to ambient).

PD = $P_{int} + P_{port}$.

P_{int} = $I_{DD} \times V_{DD}$ (chip internal power).

P_{port} = Port power dissipation (determined by the user).

Symbol	Parameter	Value	Unit	
V_{DD}	Supply Voltage	-0.3 to 7.0	V	
V_I	Input Voltage (AFC IN)	V	$V_{SS} - 0.3$ to +13	V
V_I	Input Voltage (Other Inputs)	V	$V_{SS} - 0.3$ to $V_{DD} + 0.3$	V
V_O	Output Voltage (PA4-PA7, PC4-PC7, DA0-DA5)		$V_{SS} - 0.3$ to +13	V
V_O	Output Voltage (Other Outputs)	V	$V_{SS} - 0.3$ to $V_{DD} + 0.3$	V
I_O	Current Drain per Pin Excluding V_{DD} , V_{SS} , PA6, PA7		± 10	mA
I_O	Current Drain per Pin (PA6, PA7)		± 50	mA
I_{VDD}	Total Current into V_{DD} (source)	50	mA	
I_{VSS}	Total Current out of V_{SS} (sink)	150	mA	
T_j	Junction Temperature	150	$^{\circ}C$	
T_{STG}	Storage Temperature	-60 to 150	$^{\circ}C$	

Note : Stresses above those listed as "absolute maximum ratings" may cause permanent damage to the device . This is a stress rating only and functional operation of the device at these conditions is not implied. Exposure to maximum rating conditions for extended periods may affect device reliability.

THERMAL CHARACTERISTIC

Symbol	Parameter	Test Conditions	Value			Unit
			Min.	Typ.	Max.	
R_{thJA}	Thermal Resistance	PDIP40 PDIP28			38 55	$^{\circ}C/W$

RECOMMENDED OPERATING CONDITIONS

Symbol	Parameter	Test Conditions	Value			Unit
			Min.	Typ.	Max.	
T_A	Operating Temperature	0	70	$^{\circ}C$		
V_{DD}	Operating Supply Voltage	4.5 5.0 6.0		V		
f_{osc}	Oscillator Frequency RUN & WAIT Modes			8	8.1	MHz
f_{osDOSC}	On-screen Display Oscillator Frequency				8.0	MHz

EEPROM INFORMATION

The ST631xx EEPROM single poly process has been specially developed to achieve 300.000 Write/Erase cycles and a 10 years data retention.

DC ELECTRICAL CHARACTERISTICS

(T_A = 0 to +70°C unless otherwise specified)

Symbol	Parameter	Test Conditions	Value			Unit
			Min.	Typ.	Max.	
V _{IL}	Input Low Level Voltage	All I/O Pins, KBY0-2		0.3xV	DD	V
V _{IH}	Input High Level Voltage	All I/O Pins, KBY0-2	0.75xV _{DD}			V
V _{HYS}	Hysteresis Voltage ⁽¹⁾	All I/O Pins, KBY0-2 V _{DD} = 5V		1.0		V
V _{OL}	Low Level Output Voltage	Port B/C, DA0-3, BSW0-3, OUT1, VS, OSD Outputs, V _{DD} = 4.5V I _{OL} = 1.6mA I _{OL} = 5.0mA			0.4	V
					1.0	V
V _{OL}	Low Level Output Voltage	Port A V _{DD} = 4.5V I _{OL} = 3.2mA I _{OL} = 30mA			0.4	V
					1.0	V
V _{OL}	Low Level Output Voltage	OSDOSCout, OSCout V _{DD} = 4.5V I _{OL} = 0.1mA	0.4			V
V _{OH}	High Level Output Voltage	Port B/C ⁽²⁾ , VS V _{DD} = 4.5V I _{OH} = - 1.6mA	4.1			V
V _{OH}	High Level Output Voltage	OSDOSCout, OSCout, V _{DD} = 4.5V I _{OL} = - 0.1mA	4.1			V
I _{PU}	Input Pull Up Current Input Mode with Pull-up	Port B/C, KBY0-2 V _{IN} = V _{SS} ⁽²⁾	- 100	- 50	- 25	mA
I _{IL} I _{IH}	Input Leakage Current	OSCin V _{IN} = V _{SS} V _{IN} = V _{DD}	- 10	- 1	- 0.1	μA
			0.1	1	10	
I _{IL} I _{IH}	Input Leakage Current	All I/O Input Mode no Pull-up OSDOSCin V _{IN} = V _{DD} or V _{SS}	- 10		10	μA
I _{IL} I _{IH}	Input Leakage Current	Reset Pin with Pull-up V _{IN} = V _{SS}	- 50	- 30	- 10	μA
I _{IL} I _{IH}	Input Leakage Current	AFC Pin V _{IH} = V _{DD} V _{IL} = V _{SS} V _{IH} = 12.0V	- 1		1	μA
					40	
I _{OH}	Output Leakage Current	Port A, DA0-3, BSW0-3 OUT1, OSDout V _{OH} = V _{DD}			10	μA
I _{OH}	Output Leakage Current High Voltage	Port A, DA0-3, BSW0-3 OUT1 V _{OH} = 12V			40	μA

DC ELECTRICAL CHARACTERISTICS (Continued)

Symbol	Parameter	Test Conditions	Value			Unit
			Min.	Typ.	Max.	
I _{DD}	Supply Current RUN Mode	f _{OSC} = 8MHz, I _{Load} = 0mA V _{DD} = 6.0V		6	16	mA
I _{DD}	Supply Current WAIT Mode	f _{OSC} = 8MHz, I _{Load} = 0mA V _{DD} = 6V		3	10	mA
V _{ON}	Reset Trigger Level ON	RESET Pin	0.3xV _{DD}			V
V _{OFF}	Reset Trigger Level OFF	RESET Pin	0.8xV _{DD}			V
V _{TA}	Input Level Absolute Tolerance	A/D AFC Pin V _{DD} = 5V			±200	mV
V _{TR}	Input Level Relative Tolerance	A/D AFC Pin Relative to other levels V _{DD} = 5V			±100	mV

Notes:

1. Not 100% Tested
2. Input pull-up option only

AC ELECTRICAL CHARACTERISTICS

 (T_A = 0 to +70°C, f_{OSC}=8MHz, V_{DD}=4.5 to 6.0V unless otherwise specified)

Symbol	Parameter	Test Conditions	Value			Unit
			Min.	Typ.	Max.	
t _{WRES}	Minimum Pulse Width	RESET Pin	125			ns
t _{OHL}	High to Low Transition Time	PA6, PA7 V _{DD} = 5V, CL = 1000pF (2)		100		ns
t _{OHL}	High to Low Transition Time	DA0-DA5, PB0-PB6, OSD Outputs, PC0-PC7, V _{DD} = 5V, CL = 100pF		20		ns
t _{OLH}	Low to High Transition Time	PB0-PB6, PA0-PA3, OSD Outputs, PC0-PC3 V _{DD} = 5V, CL = 100pF		20		ns
t _{OH}	Data HOLD Time SPI after clock goes low I ² CBUS/S-BUS Only		175			ns
f _{DA}	D/A Converter Repetition Frequency ⁽¹⁾		31.25			kHz
f _{SIO}	SIO Baud Rate ⁽¹⁾		62.50			kHz
t _{WEE}	EEPROM Write Time	T _A = 25°C One Byte		5	10	ms
Endurance	EEPROM WRITE/ERASE Cycles	Q _A L _{OT} Acceptance Criteria	300.000	> 1 million		cycles
Retention	EEPROM Data Retention (4)	T _A = 25°C	10			years
C _{IN}	Input Capacitance (3)	All Inputs Pins	10	pF		
C _{OUT}	Output Capacitance (3)	All outputs Pins	10	pF		
COSCin, COSCout	Oscillator Pins Internal Capacitance(3)			5		pF
COSDin, COSDout	OSD Oscillator External Capacitance	Recommended	15		25	pF

Notes:

1. A clock other than 8 MHz will affect the frequency response of those peripherals (D/A, 62.5kHz and SPI) whose clock is derived from the system clock.
2. The rise and fall times of PORT A have been reduced in order to avoid current spikes while maintaining a high drive capability
3. Not 100% Tested
4. Based on extrapolated data

PACKAGE MECHANICAL DATA

Figure 69. ST631xx 40 Pin Plastic Dual-In-line Package

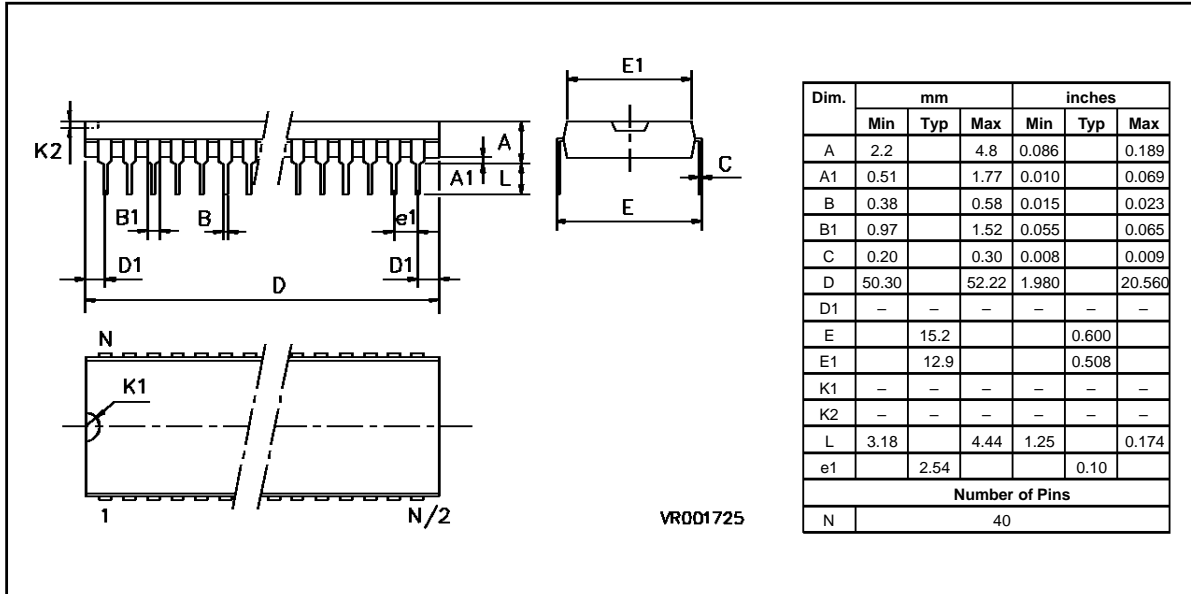
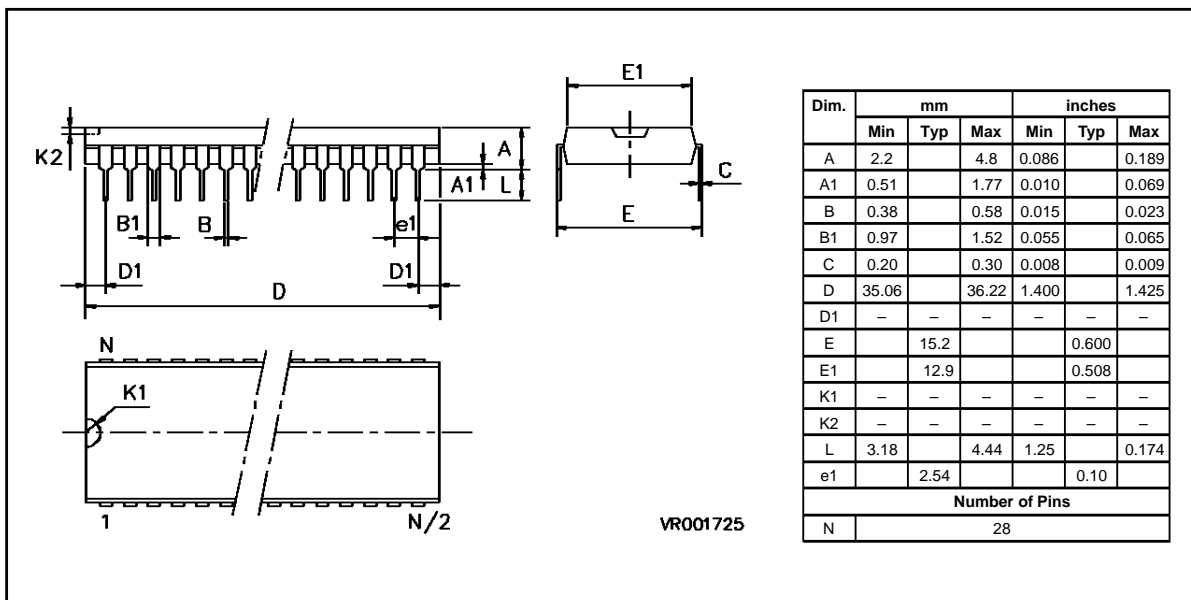

Figure 70. ST631xx 28-Pin Dual-In-line Package



ORDERING INFORMATION

The following chapter deals with the procedure for transfer the Program/Data ROM codes to SGS-THOMSON.

Communication of the ROM Codes. To communicate the contents of Program /Data ROM memories to SGS-THOMSON, the customer has to send a 5" Diskette with:

- one file in INTEL INTELLEC 8/MDS FORMAT for the PROGRAM Memory
- one file in INTEL INTELLEC 8/MDS FORMAT for the ODD and EVEN ODD OSD Characters

- one file in INTEL INTELLEC 8/MDS FORMAT for the EEPROM initial content (this file is optional)
- a filled Option List form as described in the OPTIONLIST paragraph.

The program ROM should respect the ROM Memory Map as in Table 19.

The ROM code must be generated with ST6 assembler. Before programming the EPROM, the buffer of the EPROM programmer must be filled with FFh.

Table 19. ROM Memory Map

ROM Page	Device Address	EPROM Address ⁽¹⁾	Description
Page 0	0000h-007Fh 0080h-07FFh	0000h-007Fh 0080h-07FFh	Reserved User ROM
Page 1 "STATIC"	0800h-0F9Fh 0FA0h-0FEFh 0FF0h-0FF7h 0FF8h-0FFBh 0FFCh-0FFDh 0FFEh-0FFFh	0800h-0F9Fh 0FA0h-0FEFh 0FF0h-0FF7h 0FF8h-0FFBh 0FFCh-0FFDh 0FFEh-0FFFh	User ROM Reserved Interrupt Vectors Reserved NMI Vector Reset Vector
Page 2	0000h-000Fh 0010h-07FFh	1000h-100Fh 1010h-17FFh	Reserved User ROM
Page 3	0000h-000Fh 0010h-07FFh	1800h-180Fh 1810h-1FFFh	Reserved user ROM

Note 1. EPROM addresses are related to the use of ST63E1xx EPROM emulation devices.

ORDERING INFORMATION (Continued)

Customer EEPROM Initial Contents: Format

- a. The content should be written into an INTEL INTELLEC format file.
- b. Undefined or don't care bytes should have the content FFh.

OSD Test Character. IN ORDER TO ALLOW THE TESTING OF THE ON-CHIP OSD MACROCELL THE FOLLOWING CHARACTER MUST BE PROVIDED AT THE FIXED 3Fh (63) POSITION OF THE SECOND OSD BANK.

Listing Generation & Verification. When SGS-THOMSON receives the files, a computer listing is generated from them. This listing refers exactly to the mask that will be used to produce the microcontroller. Then the listing is returned to the customer that must thoroughly check, complete, sign and

Figure 71. OSD Test Character

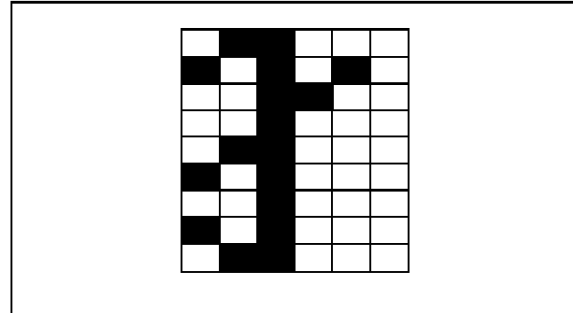

return it to SGS-THOMSON. The signed list constitutes a part of the contractual agreement for the creation of the customer mask. SGS-THOMSON sales organization will provide detailed information on contractual points.

ORDERING INFORMATION TABLE

Sales Type	ROM/EEPROM	Temperature Range	Package
ST63140B1/XX	8K (EPROM) / 0 to + 70 ° C 128 Bytes 0 to + 70 ° C 0 to + 70 ° C	0 to + 70 ° C	PDIP28
ST63142B1/XX		PDIP28	
ST63126B1/XX		PDIP40	
ST63156B1/XX		PDIP40	

Note. /XX Is the ROM Code identifier that is allocated by SGS-THOMSON after receipt of all required options and the related ROM file

ST631xx MICROCONTROLLER OPTION LIST

Customer:
 Address:
 Contact:
 Phone No:
 Reference:

Device ST63140 ST63142 ST63126 ST63156
 Temperature Range 0 to 70°C

For marking one line with 12 characters maximum is possible

Special Marking No
 Yes Line1 " _____ "

Letters, digits, ' . , ' - , ' / ' and spaces only
 the default marking is equivalent to the sales type only (part number).

OSD POLARITY OPTIONS (Put a cross on selected item) :

	POSITIVE	NEGATIVE
VSYNC,HSYNC	<input type="checkbox"/>	<input type="checkbox"/>
R,G,B	<input type="checkbox"/>	<input type="checkbox"/>
BLANK	<input type="checkbox"/>	<input type="checkbox"/>

CHECK LIST:

	YES	NO
ROM CODE	<input type="checkbox"/>	<input type="checkbox"/>
OSD Code: ODD & EVEN	<input type="checkbox"/>	<input type="checkbox"/>
EEPROM Code (if Desired)	<input type="checkbox"/>	<input type="checkbox"/>

Signature

Date

**8-BIT EPROM HCMOS MCUs FOR
TV FREQUENCY & VOLTAGE SYNTHESIS WITH OSD**

PRELIMINARY DATA

- 4.5 to 6V operating Range
- 8MHz Maximum Clock Frequency
- User Program EPROM: 7948 bytes
- Reserved Test EPROM: 244 bytes
- Data EPROM: user selectable size
- Data RAM: 256 bytes
- Data EEPROM: 128 bytes
- 40-Pin Dual in Line Package for the ST63x126, x156
- 28-Pin Dual in Line Package for the ST63x140, x142
- Up to 18 software programmable general purpose Inputs/Outputs, including 8 direct LED driving Outputs
- 3 Inputs for keyboard scan (KBY0-2)
- Up to 4 high voltage outputs (BSW0-3)
- Two Timers each including an 8-bit counter with a 7-bit programmable prescaler
- Digital Watchdog Function
- Serial Peripheral Interface (SPI) supporting S-BUS/I²C BUS and standard serial protocols
- Up to Four 6-bit PWM D/A Converters
- 62.5kHz Output pin
- 14 bit counter for voltage synthesis tuning (ST63156, ST63140)
- AFC A/D converter with 0.5V resolution
- Four interrupt vectors (IRIN/NMI, Timer 1 & 2, VSYNC.)
- On-chip clock oscillator
- 5 Lines by 15 Characters On-Screen Display Generator with 128 Characters (2 banks)
- These EPROM and OTP versions are fully pin to pin compatible with their respective ROM versions
- The development tool of the ST631xx microcontrollers consists of the ST63TVS-EMU emulation and development system to be connected via a standard RS232 serial line to an MS-DOS Personal Computer.
- EPROM programming board ST63E1XX-EPB

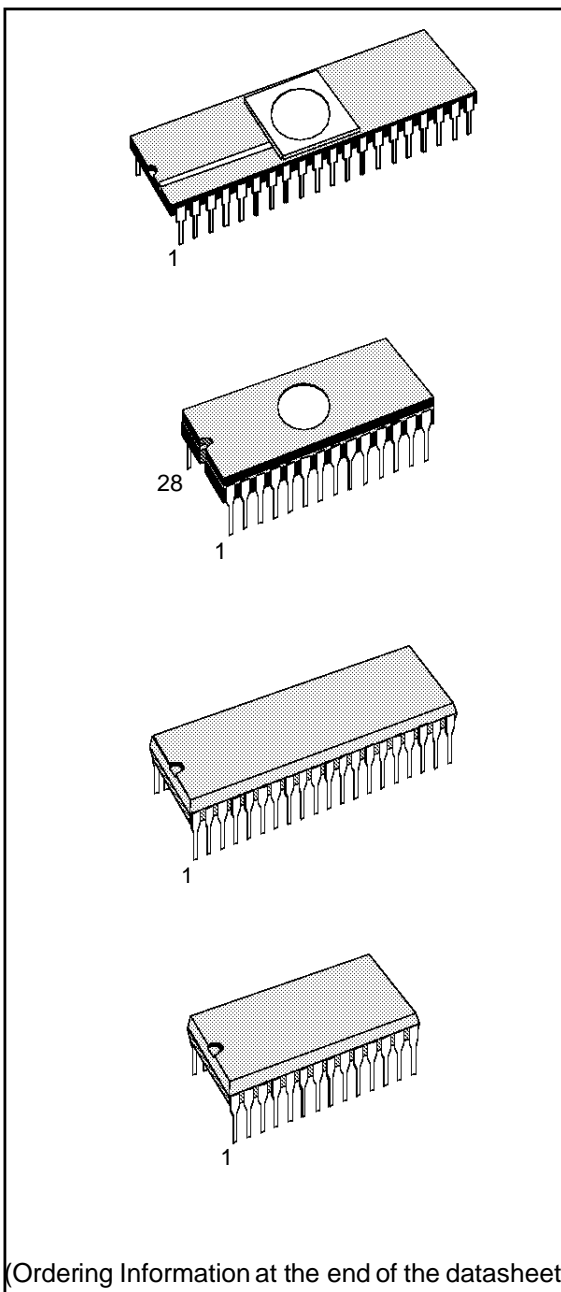

ST63E140,E142,E126,E156, T140,T142,T126,T156

Figure 1. ST63E126/T126, E156/T156 Pin Configuration

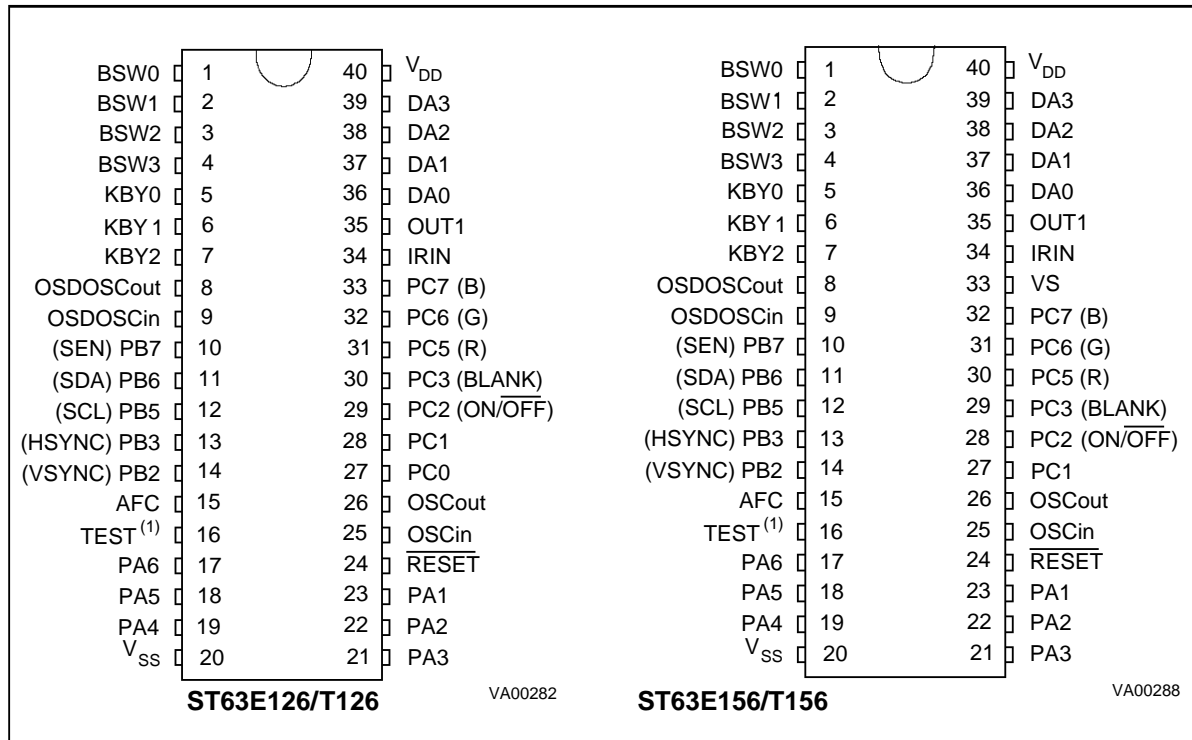

Note 1. This pin is also the VPP input for EPROM based devices

Figure 2. ST63E140/T140, E142/T142 Pin Configuration

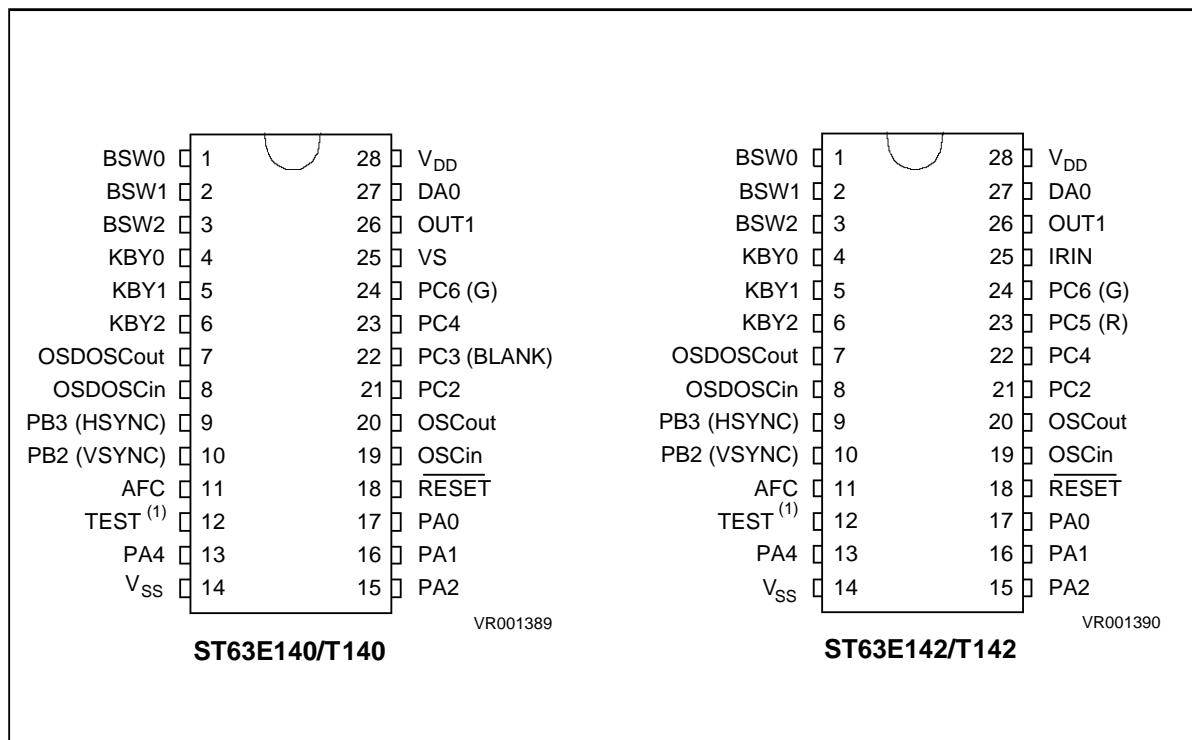

Note 1. This pin is also the VPP input for EPROM based devices

GENERAL DESCRIPTION

The ST63E140/T140, E142/T142, E126/T126, E156/T156 microcontrollers are members of the 8-bit HCMOS ST631xx family, a series of devices specially oriented to TV applications. Different peripheral configurations are available to give the maximum application and cost flexibility. All ST631xx members are based on a building block approach: a common core is surrounded by a combination of on-chip peripherals (macrocells) available from a standard library. These peripherals are designed with the same Core technology providing full compatibility and short design time. Many of these macrocells are specially dedicated to TV applications.

The macrocells of the ST631xx family are: two Timer peripherals each including an 8-bit counter

with a 7-bit software programmable prescaler (Timer), a digital hardware activated watchdog function (DHWD), a 14-bit voltage synthesis tuning peripheral, a Serial Peripheral Interface (SPI), up to four 6-bit PWM D/A converters, an AFC A/D converter with 0.5V resolution, an on-screen display (OSD) with 15 characters per line and 128 characters (in two banks each of 64 characters). In addition the following Memory resources are available: program EPROM (8K), data RAM (256 bytes), EEPROM (128 bytes).

Refer to pin configuration figures and to ST631xx device summary (Table 1) for the definition of ST631xx family members and a summary of differences among the different types.

Figure 3. ST631xx family Block Diagram

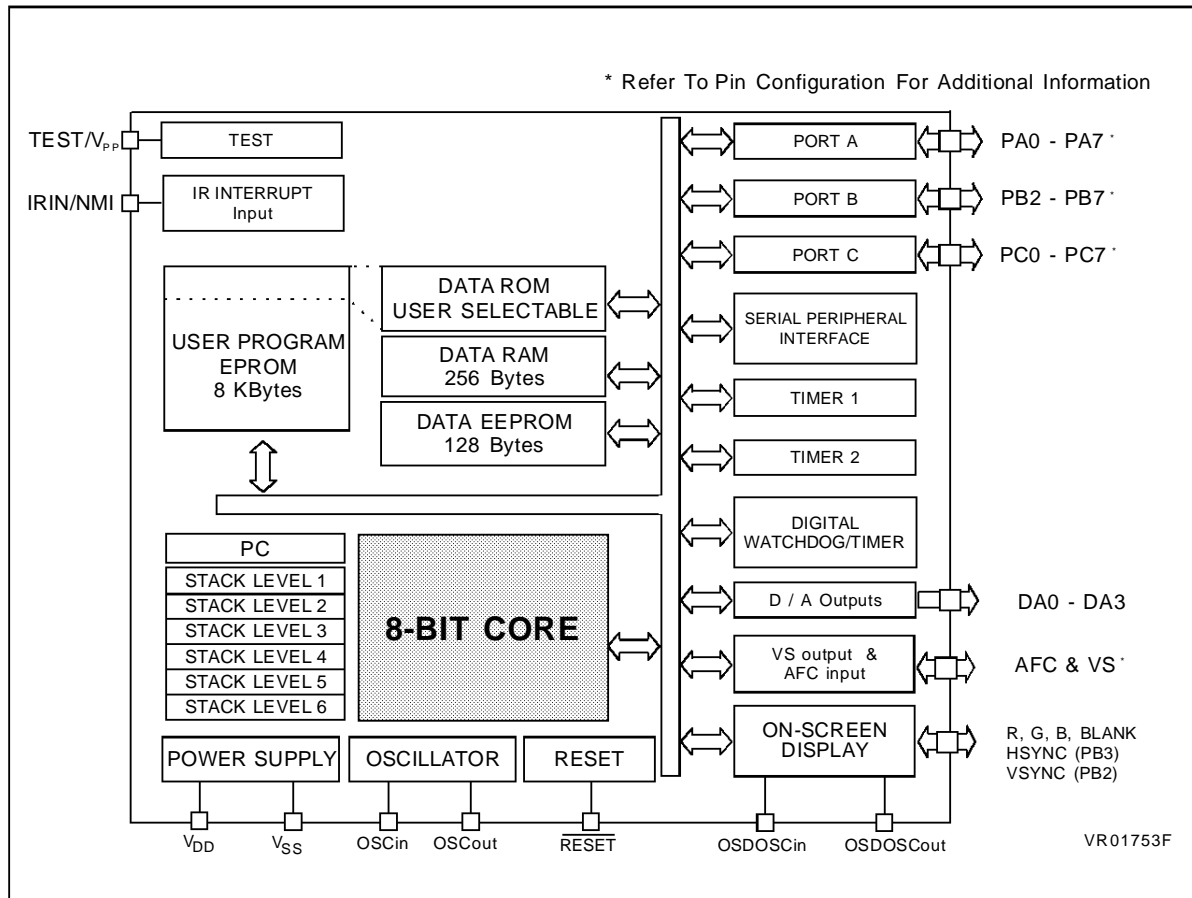

Table 1. Device Summary

DEVICE	EPROM (Bytes)	OTP ROM (Bytes)	RAM (Bytes)	EEPROM (Bytes)	I/O	KBY I/O	BSW OUT	AFC	VS	D/A	PACK.	TARGET ROM DEVICES
ST63E140	8K		256	128	6	3	3	YES	YES	1	PDIP28	ST63140
ST63T140		8K	256	128	6	3	3	YES	YES	1	PDIP28	ST63140
ST63E142	8K		256	128	6	3	3	YES	NO	1	PDIP28	ST63142
ST631T42		8K	256	128	6	3	3	YES	NO	1	PDIP28	ST63142
ST63E126	8K		256	128	12	3	4	YES	NO	4	PDIP40	ST63126
ST63T126		8K	256	128	12	3	4	YES	NO	4	PDIP40	ST63126
ST63E156	8K		256	128	11	3	4	YES	YES	4	PDIP40	ST63156
ST63T156		8K	256	128	11	3	4	YES	YES	4	PDIP40	ST63156

PIN DESCRIPTION

V_{DD} and V_{SS}. Power is supplied to the MCU using these two pins. V_{DD} is power and V_{SS} is the ground connection.

OSCin, OSCout. These pins are internally connected to the on-chip oscillator circuit. A quartz crystal or a ceramic resonator can be connected between these two pins in order to allow the correct operation of the MCU with various stability/cost trade-offs. The OSCin pin is the input pin, the OSCout pin is the output pin.

RESET. The active low $\overline{\text{RESET}}$ pin is used to start the microcontroller to the beginning of its program.

TEST/V_{PP}. The TEST pin must be held at V_{SS} for normal operation. If this pin is connected to a 12.5V level during the reset phase, the EPROM programming mode is entered.

Caution. Exceeding 13V on TEST/V_{PP} pin will permanently damaged the device.

PA0-PA7. These 8 lines are organized as one I/O port (A). Each line may be configured as either an input or as an output under software control of the data direction register. Port A has an open-drain (12V drive) output configuration with direct LED driving capability (30mA, 1V).

PB2-PB3, PB5-PB7. These lines are organized as one I/O port (B). Each line may be configured as either an input with or without internal pull-up resistor or as an output under software control of the data direction register. PB2-PB3 have a push-pull configuration in output mode while PB5-PB7 are open-drain (5V drive).

PB2 and PB3 lines are connected to the VSYNC and HSYNC control signals of the OSD cell; to provide the right signals to the OSD these I/O lines should be programmed in input mode and the user can read "on the fly" the state of VSYNC and HSYNC signals. PB2 is also connected with the VSYNC Interrupt. The active polarity of VSYNC Interrupt signal is software controlled. The active polarity of these synchronization input pins to the OSD macrocell can be selected by the user as ROM mask option. If the device is specified to have negative logic inputs, then when these signals are low the OSD oscillator stops. If the device is specified to have positive logic inputs, then when these signals are high the OSD oscillator stops.

PB5, PB6 and PB7 lines, when in output modes, are "ANDed" with the SPI control signals. PB5 is connected with the SPI clock signal (SCL), PB6 with the SPI data signal (SDA) while PB7 is connected with SPI enable signal (SEN).

PC0-PC7. These 8 lines are organized as one I/O port (C). Each line may be configured as either an input with or without internal pull-up resistor or as an output under software control of the data direction register. PC0-PC2, PC4 have a push-pull configuration in output mode while PC3, PC5-PC7 (OSD signals) are open-drain (5V drive). PC3, PC5, PC6 and PC7 lines when in output mode are "ANDed" with the character and blank signals of the OSD cell. PC3 is connected with the OSD BLANK signal, PC5, PC6 and PC7 with the OSD R, G and B signals. The active polarity of these signals can be selected by the user as ROM mask option. PC2 is also used as TV set ON-OFF switch (5V drive).

DA0-DA3. These pins are the four PWM D/A outputs (with 32kHz repetition) of the 6-bit on-chip D/A converters. The PWM function can be disabled by software and these lines can be used as general purpose open-drain outputs (12V drive).

IRIN. This pin is the external NMI of the MCU.

OUT1. This pin is the 62.5kHz output specially suited to drive multi-standard chroma processors. This function can be disabled by software and the pin can be used as general purpose open-drain output (12V drive).

BSW0-BSW3. These output pins can be used to select up to 4 tuning bands. These lines are configured as open-drain outputs (12V drive).

KBY0-KBY2. These pins are input only and can be used for keyboard scan. They have CMOS threshold levels with Schmitt Trigger and on-chip 100k Ω pull-up resistors.

AFC. This is the input of the on-chip 10 level comparator that can be used to implement the AFC function. This pin is an high impedance input able to withstand signals with a peak amplitude up to 12V.

OSDOScin, OSDOScout. These are the On Screen Display oscillator terminals. An oscillation capacitor and coil network have to be connected to provide the right signal to the OSD.

VS. This is the output pin of the on-chip 14-bit voltage synthesis tuning cell (VS). The tuning signal present at this pin gives an approximate resolution of 40kHz per step over the UHF band. This line is a push-pull output with standard drive (ST63140, ST63156 only).

PIN DESCRIPTION (Continued)**Table 2. Pin Summary**

Pin Function	Description
DA0 to DA3	Output, Open-Drain, 12V
BSW0 to BSW3	Output, Open-Drain, 12V
IRIN	Input, Resistive Bias, Schmitt Trigger
AFC	Input, High Impedance, 12V
OUT1	Output, Open-Drain, 12V
KBY0 to KBY2	Input, Pull-up, Schmitt Trigger
R,G,B, BLANK	Output, Open-Drain, 5V
HSYNC, VSYNC	Input, Pull-up, Schmitt Trigger
OSDOSCin	Input, High Impedance
OSDOSCout	Output, Push-Pull
TEST/V _{PP}	Input, Pull-Down
OSCin	Input, Resistive Bias, Schmitt Trigger to Reset Logic Only
OS Cout	Output, Push-Pull
RESET	Input, Pull-up, Schmitt Trigger Input
VS	Output, Push-Pull
PA0-PA6	I/O, Open-Drain, 12V, No Input Pull-up, Schmitt Trigger, High Drive
PB2-PB3, PB5-PB7	I/O, Push-Pull, 5V, Input Pull-up, Schmitt Trigger
PB5-PB7	I/O, Open-Drain, 5V, Input Pull-up, Schmitt Trigger
PC0-PC2, PC4	I/O, Push-Pull, 5V, Input Pull-up, Schmitt Trigger
PC3, PC5-PC7	I/O, Open-Drain, 5V, Input Pull-up, Schmitt Trigger
V _{DD} , V _{SS}	Power Supply Pins

MEMORY SPACE

Table 3. EPROM Memory Map

EPROM Page	Device Address	EPROM Address	Description
Page 0	0000h-007Fh 0080h-07FFh	0000h-007Fh 0080h-07FFh	Reserved User ROM
Page 1 "STATIC"	0800h-0F9Fh 0FA0h-0FEFh 0FF0h-0FF7h 0FF8h-0FFBh 0FFCh-0FFDh 0FFEh-0FFFh	0800h-0F9Fh 0FA0h-0FEFh 0FF0h-0FF7h 0FF8h-0FFBh 0FFCh-0FFDh 0FFEh-0FFFh	User ROM Reserved Interrupt Vectors Reserved NMI Vector Reset Vector
Page 2	0000h-000Fh 0010h-07FFh	1000h-100Fh 1010h-17FFh	Reserved User ROM
Page 3	0000h-000Fh 0010h-07FFh	1800h-180Fh 1810h-1FFFh	Reserved user ROM

EPROM/OTP DESCRIPTION.

The ST63E1xx represents the generic part number for the EPROM versions of the ST63140, 42, 26, 56 ROM products. They are intended for use during the development of an application, and for pre-production and small volume production.

The ST63T1xx OTP have the same characteristics.

They both include EPROM memory instead of the ROM memory of the ST631xx, and so the program and constants of the program can be easily modified by the user with the ST63E1XX EPROM Programming Board from SGS-THOMSON.

The ROM mask options of the ST631xx for OSD polarities (HSYNC, VSYNC, R, G, B, BLANK) are emulated with an **EPROM OPTION BYTE**. This is programmed by the SGS-THOMSON EPROM programming board and its associated software.

The EPROM Option Byte content will define the OSD options as follows :

7							0
Opt7	Opt6	Opt5	Opt4	Opt3	Opt 2	Opt 1	Opt 0

Opt7-Opt6. Device specific bits ⁽¹⁾

Opt5 : This bit define the BLANK polarity, if 0 the polarity will be negative if 1 the polarity will be positive..

Opt 4 : This bit define the RGB polarity, if 0 the polarity will be negative if 1 the polarity will be positive..

Opt 3 : This bit define the OSD H/Vsync polarity, if 0 the polarity will be negative if 1 the polarity will be positive.

Opt2-Opt0. Device specific bits ⁽¹⁾

Note 1. Device specific bits. These reserved bits must be programmed according to the following table for their relevant device.

Sales Type	Opt7-Opt6	Opt2-Opt0
ST63E140/T140	0 0	1 0 0
ST63E142/T142	0 0	1 0 1
ST63E126/T126	0 0	1 0 1
ST63E156/T156	0 0	1 0 1

From a user point of view (with the following exceptions) the ST63E1xx,T1xx products have exactly the same software and hardware features of the ROM version. An additional mode is used to configure the part for programming of the EPROM, this is set by a +12.5V voltage applied to the TEST/V_{PP} pin. The programming of the ST63E1xx,T1xx is described in the User Manual of the EPROM Programming board.

On the ST63E1xx, all the 7948 bytes of PROGRAM memory are available for the user, as all the EPROM memory can be erased by exposure to UV light. On the ST63T1xx (OTP device) a reserved area for test purposes exists, as for the ST631xx ROM device. In order to avoid any discrepancy between program functionality when using the EPROM, OTP and ROM it is recommended NOT TO USE THESE RESERVED AREAS, even when using the ST63E1xx. The Table 3 is a summary of the EPROM/ROM Map and its reserved area.

THE READER IS ASKED TO REFER TO THE DATASHEET OF THE ST631xx ROM-BASED DEVICE FOR FURTHER DETAILS.

EPROM ERASING

The EPROM of the windowed package of the ST63E1xx may be erased by exposure to Ultra Violet light.

The erasure characteristic of the ST63E1xx EPROM is such that erasure begins when the memory is exposed to light with wave lengths shorter than approximately 4000Å. It should be noted that sunlight and some types of fluorescent lamps have wavelengths in the range 3000-4000Å. It is thus recommended that the window of the ST63E1xx package be covered by an opaque label to prevent unintentional erasure problems when testing the application in such an environment. The recommended erasure procedure of the ST63E1xx EPROM is exposure to short wave ultraviolet light which has wavelength 2537Å. The integrated dose (i.e. UV intensity x exposure time) for erasure should be a minimum of 15 W-sec/cm². The erasure time with this dosage is approximately 15 to 20 minutes using an ultraviolet lamp with 12000µW/cm² power rating. The ST63E1xx should be placed within 2.5 cm (1 inch) of the lamp tubes during erasure.

ABSOLUTE MAXIMUM RATINGS

This product contains devices to protect the inputs against damage due to high static voltages, however it is advised to take normal precaution to avoid application of any voltage higher than maximum rated voltages.

For proper operation it is recommended that V_I and V_O must be higher than V_{SS} and smaller than V_{DD} . Reliability is enhanced if unused inputs are connected to an appropriated logic voltage level (V_{DD} or V_{SS}).

Power Considerations. The average chip-junction temperature, T_j , in Celsius can be obtained from :

$$T_j = T_A + PD \times R_{thJA}$$

Where : T_A = Ambient Temperature.

R_{thJA} = Package thermal resistance (junction-to ambient).

PD = $P_{int} + P_{port}$.

P_{int} = $I_{DD} \times V_{DD}$ (chip internal power).

P_{port} = Port power dissipation (determined by the user).

Symbol	Parameter	Value	Unit	
V_{DD}	Supply Voltage	-0.3 to 7.0	V	
V_I	Input Voltage (AFC IN)	V	$V_{SS} - 0.3$ to $+13$	V
V_I	Input Voltage (Other Inputs)	V	$V_{SS} - 0.3$ to $V_{DD} + 0.3$	V
V_O	Output Voltage (PA4-PA7, PC4-PC7, DA0-DA5)		$V_{SS} - 0.3$ to $+13$	V
V_O	Output Voltage (Other Outputs)	V	$V_{SS} - 0.3$ to $V_{DD} + 0.3$	V
V_{PP}	EPROM programming Voltage	-0.3 to 13.0	V	
I_O	Current Drain per Pin Excluding V_{DD} , V_{SS} , PA6, PA7		± 10	mA
I_O	Current Drain per Pin (PA6, PA7)		± 50	mA
I_{VDD}	Total Current into V_{DD} (source)	50	mA	
I_{VSS}	Total Current out of V_{SS} (sink)	150	mA	
T_j	Junction Temperature	150	$^{\circ}C$	
T_{STG}	Storage Temperature	-60 to 150	$^{\circ}C$	

Note : Stresses above those listed as "absolute maximum ratings" may cause permanent damage to the device . This is a stress rating only and functional operation of the device at these conditions is not implied. Exposure to maximum rating conditions for extended periods may affect device reliability.

RECOMMENDED OPERATING CONDITIONS

Symbol	Parameter	Test Conditions	Value			Unit
			Min.	Typ.	Max.	
T_A	Operating Temperature	0	70	$^{\circ}C$		
V_{DD}	Operating Supply Voltage	4.5 5.0	6.0	V		
f_{osc}	Oscillator Frequency RUN & WAIT Modes			8	8.1	MHz
f_{osDOSC}	On-screen Display Oscillator Frequency				8.0	MHz

ST63E140,E142,E126,E156, T140,T142,T126,T156

EEPROM INFORMATION

The ST631xx EEPROM single poly process has been specially developed to achieve 300.000 Write/Erase cycles and a 10 years data retention.

DC ELECTRICAL CHARACTERISTICS

(T_A = 0 to +70°C unless otherwise specified)

Symbol	Parameter	Test Conditions	Value			Unit
			Min.	Typ.	Max.	
V _{IL}	Input Low Level Voltage	All I/O Pins, KBY0-2		0.3xV _{DD}		V
V _{IH}	Input High Level Voltage	All I/O Pins, KBY0-2	0.75xV _{DD}			V
V _{HYS}	Hysteresis Voltage ⁽¹⁾	All I/O Pins, KBY0-2 V _{DD} = 5V		1.0		V
V _{OL}	Low Level Output Voltage	Port B/C, DA0-3, BSW0-3, OUT1, VS, OSD Outputs, V _{DD} = 4.5V I _{OL} = 1.6mA I _{OL} = 5.0mA			0.4	V
					1.0	V
V _{OL}	Low Level Output Voltage	Port A V _{DD} = 4.5V I _{OL} = 3.2mA I _{OL} = 30mA			0.4 1.0	V V
V _{OL}	Low Level Output Voltage	OSDOS _{Cout} , OSC _{Cout} V _{DD} = 4.5V I _{OL} = 0.1mA	0.4			V
V _{OH}	High Level Output Voltage	Port B/C ⁽²⁾ , VS V _{DD} = 4.5V I _{OH} = -1.6mA	4.1			V
V _{OH}	High Level Output Voltage	OSDOS _{Cout} , OSC _{Cout} , V _{DD} = 4.5V I _{OL} = -0.1mA	4.1			V
I _{PU}	Input Pull Up Current Input Mode with Pull-up	Port B/C, KBY0-2 V _{IN} = V _{SS} ⁽²⁾	- 100	- 50	- 25	mA
I _{IL} I _{IH}	Input Leakage Current	OSC _{in} V _{IN} = V _{SS} V _{IN} = V _{DD}	- 10	- 1	- 0.1	μA
			0.1	1	10	
I _{IL} I _{IH}	Input Leakage Current	All I/O Input Mode no Pull-up OSDOS _{Cin} V _{IN} = V _{DD} or V _{SS}	- 10		10	μA
I _{IL} I _{IH}	Input Leakage Current	Reset Pin with Pull-up V _{IN} = V _{SS}	- 50	- 30	- 10	μA
I _{IL} I _{IH}	Input Leakage Current	AFC Pin V _{IH} = V _{DD} V _{IL} = V _{SS} V _{IH} = 12.0V	- 1		1	μA
					40	
I _{OH}	Output Leakage Current	Port A, DA0-3, BSW0-3 OUT1, OSD _{out} V _{OH} = V _{DD}			10	μA
I _{OH}	Output Leakage Current High Voltage	Port A, DA0-3, BSW0-3 OUT1 V _{OH} = 12V			40	μA

DC ELECTRICAL CHARACTERISTICS (Continued)

Symbol	Parameter	Test Conditions	Value			Unit
			Min.	Typ.	Max.	
I _{DD}	Supply Current RUN Mode	f _{OSC} = 8MHz, I _{Load} = 0mA V _{DD} = 6.0V		6	16	mA
I _{DD}	Supply Current WAIT Mode	f _{OSC} = 8MHz, I _{Load} = 0mA V _{DD} = 6V		3	10	mA
V _{ON}	Reset Trigger Level ON	RESET Pin	0.3xV _{DD}			V
V _{OFF}	Reset Trigger Level OFF	RESET Pin	0.8xV _{DD}			V
V _{TA}	Input Level Absolute Tolerance	A/D AFC Pin V _{DD} = 5V			±200	mV
V _{TR}	Input Level Relative Tolerance	A/D AFC Pin Relative to other levels V _{DD} = 5V			±100	mV

ST63E140,E142,E126,E156, T140,T142,T126,T156

AC ELECTRICAL CHARACTERISTICS

($T_A = 0$ to $+70^\circ\text{C}$, $f_{\text{OSC}}=8\text{MHz}$, $V_{\text{DD}}=4.5$ to 6.0V unless otherwise specified)

Symbol	Parameter	Test Conditions	Value			Unit
			Min.	Typ.	Max.	
t_{WRES}	Minimum Pulse Width	RESET Pin	125			ns
t_{OHL}	High to Low Transition Time	PA6, PA7 $V_{\text{DD}} = 5\text{V}$, $\text{CL} = 1000\text{pF}$ (2)		100		ns
t_{OHL}	High to Low Transition Time	DA0-DA5, PB0-PB6, OSD Outputs, PC0-PC7, $V_{\text{DD}} = 5\text{V}$, $\text{CL} = 100\text{pF}$		20		ns
t_{OLH}	Low to High Transition Time	PB0-PB6, PA0-PA3, OSD Outputs, PC0-PC3 $V_{\text{DD}} = 5\text{V}$, $\text{CL} = 100\text{pF}$		20		ns
t_{OH}	Data HOLD Time SPI after clock goes low $I^2\text{CBUS/S-BUS}$ Only		175			ns
f_{DA}	D/A Converter Repetition Frequency ⁽¹⁾		31.25			kHz
f_{SIO}	SIO Baud Rate ⁽¹⁾		62.50			kHz
t_{WEE}	EEPROM Write Time	$T_A = 25^\circ\text{C}$ One Byte		5	10	ms
Endurance	EEPROM WRITE/ERASE Cycles	Q_A LOT Acceptance Criteria	300.000	> 1 million		cycles
Retention	EEPROM Data Retention (4)	$T_A = 25^\circ\text{C}$	10			years
C_{IN}	Input Capacitance (3)	All Inputs Pins	10	pF		
C_{OUT}	Output Capacitance (3)	All outputs Pins	10	pF		
COSCin, COSCout	Oscillator Pins Internal Capacitance(3)			5		pF
COSDin, COSDout	OSD Oscillator External Capacitance	Recommended	15		25	pF

Notes:

1. A clock other than 8 MHz will affect the frequency response of those peripherals (D/A, 62.5kHz and SPI) whose clock is derived from the system clock.
2. The rise and fall times of PORT A have been reduced in order to avoid current spikes while maintaining a high drive capability
3. Not 100% Tested
4. Based on extrapolated data

PACKAGE MECHANICAL DATA

Figure 69. 40 Pin Ceramic Dual-In-line Package

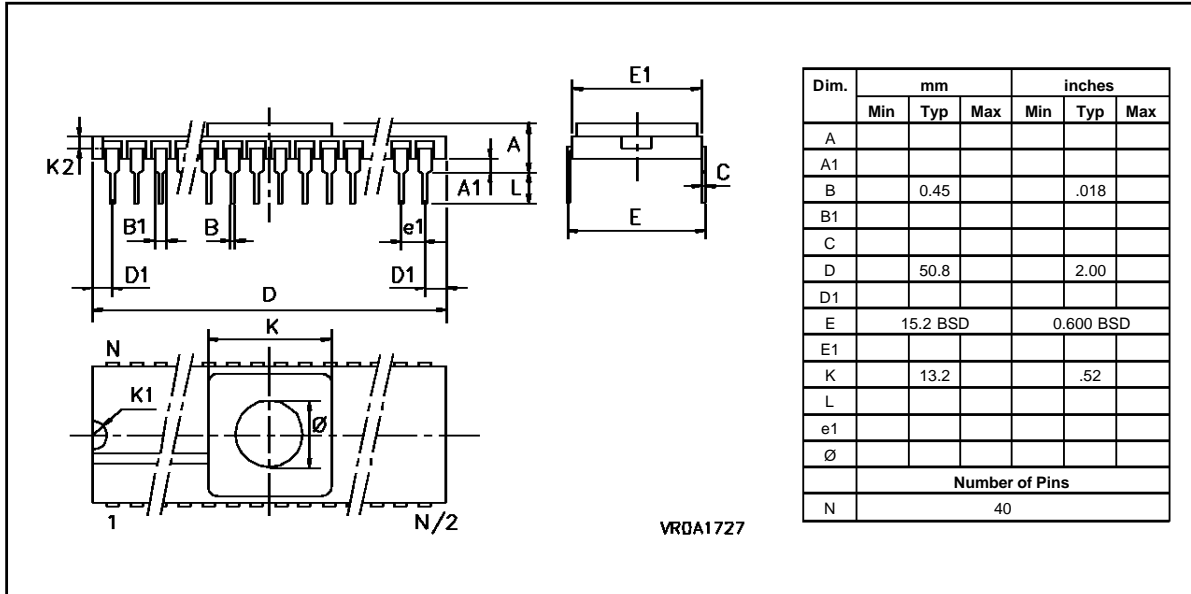
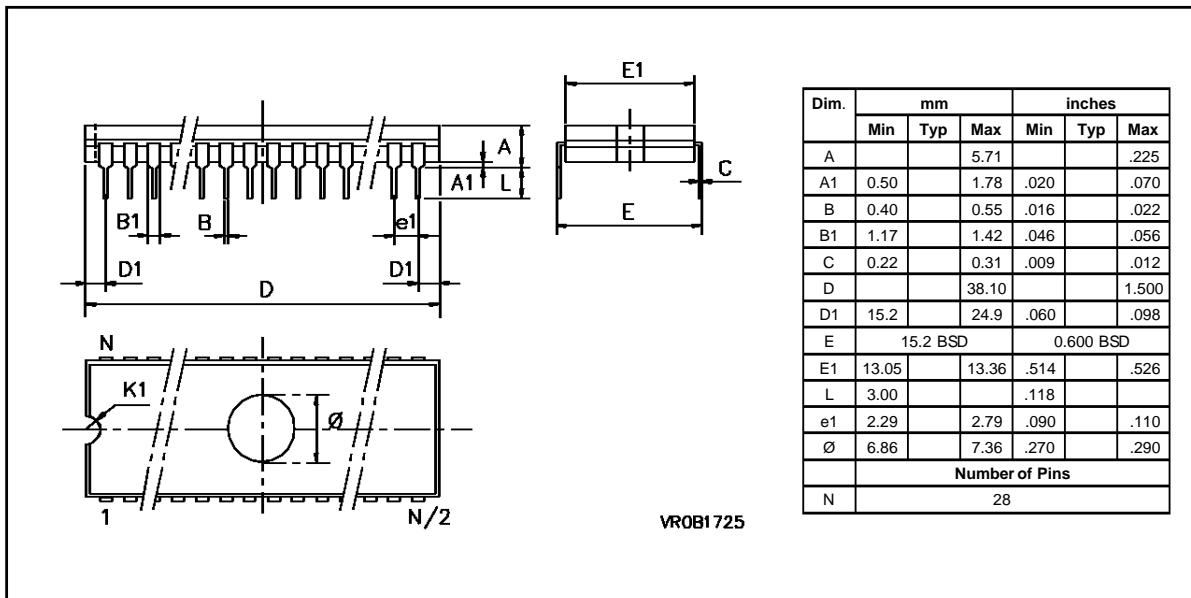

Figure 70. 28-Pin Ceramic Dual-In-line Package



ORDERING INFORMATION

To ensure compatibility between the EPROM/OTP parts and the corresponding ROM families, the following information is provided. The user should take this information into account when programming the memory and OSD characters of the EPROM parts.

Communication of the ROM Codes. To communicate the contents of memories to SGS-THOMSON, the customer has to send:

- one file in INTEL INTELLEC 8/MDS FORMAT (either as an EPROM or in a MS-DOS 5" diskette) for the ODD and EVEN OSD Character OSD ROM/EEPROM
- one file in INTEL INTELLEC 8/MDS FORMAT (either as an EPROM or in a MS-DOS 5" diskette) for the EEPROM initial content (this file is optional)
- a filled Option List form as described in the OPTION LIST paragraph.

The ROM code must be generated with ST6 assembler. Before programming the EPROM, the buffer of the EPROM programmer must be filled with FFh.

For shipment to SGS-THOMSON the EPROMs should be placed in a conductive IC carrier and packaged carefully.

**Customer EEPROM Initial Contents:
Format**

- a. The content should be written into an INTEL INTELLEC format file.
- b. Undefined or don't care bytes should have the content FFh.

OSD Test Character. IN ORDER TO ALLOW THE TESTING OF THE ON-CHIP OSD MACROCELL THE FOLLOWING CHARACTER MUST BE PROVIDED AT THE FIXED 3Fh (63) POSITION OF THE SECOND OSD BANK.

Listing Generation & Verification. When SGS-THOMSON receives the files, a computer listing is generated from them. This listing refers exactly to the mask that will be used to produce the microcontroller. Then the listing is returned to the customer that must thoroughly check, complete, sign and return it to SGS-THOMSON. The signed list constitutes a part of the contractual agreement for the creation of the customer mask. SGS-THOMSON sales organization will provide detailed information on contractual points.

Figure 71. OSD Test Character

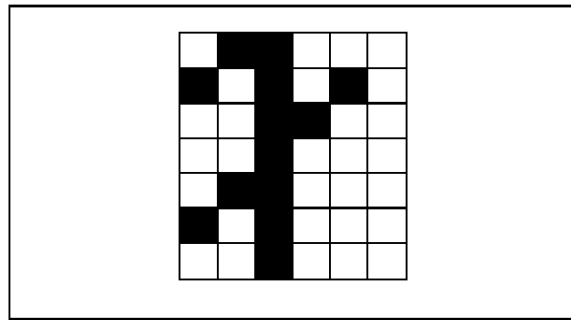

ST63E140,E142,E126,E156, T140,T142,T126,T156

ORDERING INFORMATION TABLE

Sales Type	ROM/EEPROM	Temperature Range	Package
ST63E140D1	8K (EPROM) 0 to +70 °C 128 Bytes 0 to +70 °C	0 to +70 °C	CDIP28
ST63E142D1		CDIP28	
ST63E126D1		CDIP40	
ST63E156D1		CDIP40	
ST63T140B1	8K (OTPROM) 0 to +70 °C 128 Bytes 0 to +70 °C	0 to +70 °C	PDIP28
ST63T142B1		PDIP28	
ST63T126B1		PDIP40	
ST63T156B1		PDIP40	

Information furnished is believed to be accurate and reliable. However, SGS-THOMSON Microelectronics assumes no responsibility for the consequences of use of such information nor for any infringement of patents or other rights of third parties which may result from its use. No license is granted by implication or otherwise under any patent or patent rights of SGS-THOMSON Microelectronics. Specifications mentioned in this publication are subject to change without notice. This publication supersedes and replaces all information previously supplied. SGS-THOMSON Microelectronics products are not authorized for use as critical components in life support devices or systems without the express written approval of SGS-THOMSON Microelectronics.

© 1994 SGS-THOMSON Microelectronics - All rights reserved.

Purchase of I²C Components by SGS-THOMSON Microelectronics conveys a license under the Philips I²C Patent. Rights to use these components in an I²C system is granted provided that the system conforms to the I²C Standard Specification as defined by Philips.

SGS-THOMSON Microelectronics Group of Companies

Australia - Brazil - France - Germany - Hong Kong - Italy - Japan - Korea - Malaysia - Malta - Morocco - The Netherlands
Singapore - Spain - Sweden - Switzerland - Taiwan - Thailand - United Kingdom - U.S.A.