



# LE00AB/C SERIES

## VERY LOW DROP VOLTAGE REGULATORS WITH INHIBIT

- VERY LOW DROPOUT VOLTAGE (0.2V TYP.)
- VERY LOW QUIESCENT CURRENT (TYP. 50 $\mu$ A IN OFF MODE, 0.5mA IN ON MODE, NO LOAD)
- OUTPUT CURRENT UP TO 100 mA
- OUTPUT VOLTAGES OF 1.25; 1.5; 2.5; 2.7; 3; 3.3; 3.5; 4; 4.5; 4.7; 5; 5.2; 5.5; 6; 8V
- INTERNAL CURRENT AND THERMAL LIMIT
- ONLY 2.2 $\mu$ F FOR STABILITY
- AVAILABLE IN  $\pm 1\%$  (A) OR  $\pm 2\%$  (C) SELECTION AT 25  $^{\circ}$ C
- SUPPLY VOLTAGE REJECTION: 80 db (TYP.)
- TEMPERATURE RANGE: -40 TO 125  $^{\circ}$ C

### DESCRIPTION

The LE00 regulator series are very Low Drop regulators available in SO-8 and TO-92 packages and in a wide range of output voltages.

The very Low Drop voltage (0.2V) and the very low quiescent current make them particularly suitable for Low Noise Low Power applications and specially in battery powered systems.

They are pin to pin compatible with the older L78L00 series. Furthermore in the 8 pin configuration (SO-8) they employ a Shutdown Logic Control (pin 5, TTL compatible). This means that when the device is used as a local

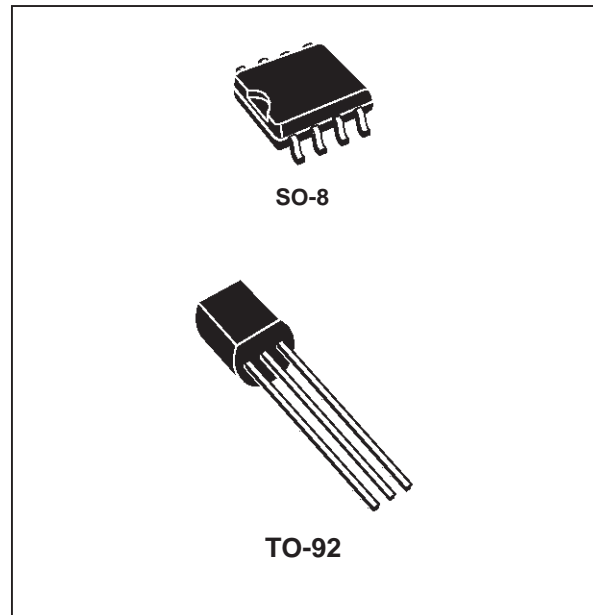

regulator, it's possible to put in stand by a part of the board even more decreasing the total power consumption. In the three terminal configuration (TO-92) the device is even in ON STATE, maintaining the same electrical performances. It needs only 2.2 $\mu$ F capacitor for stability allowing room and cost saving effect.

### SCHEMATIC DIAGRAM

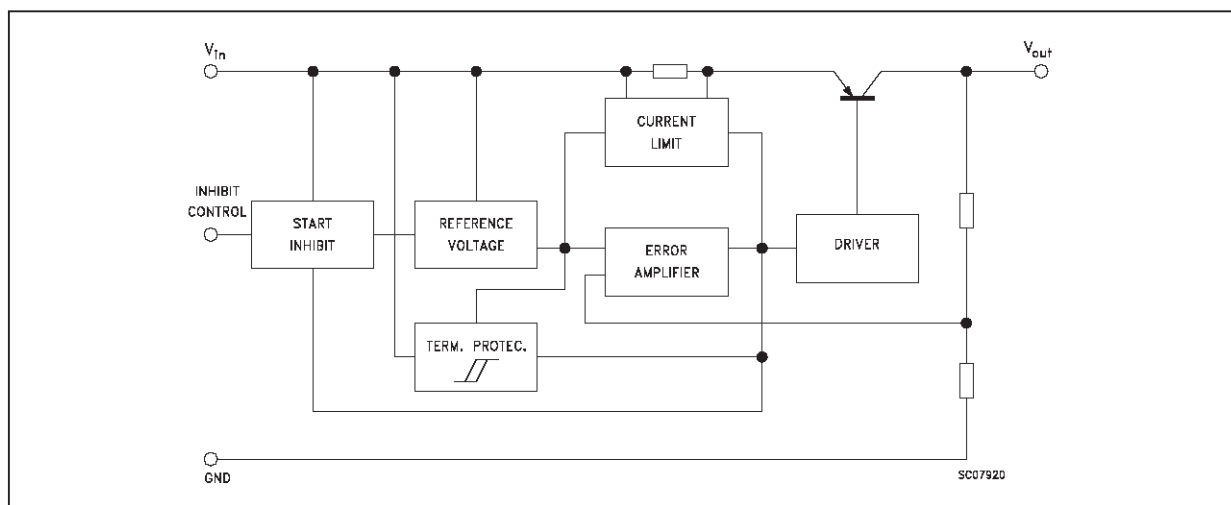

# LE00AB/C

## ABSOLUTE MAXIMUM RATING

Symbol	Parameter	Value	Unit
$V_i$	DC Input Voltage	20	V
$I_o$	Output Current	Internally limited (*)	
$P_{tot}$	Power Dissipation	Internally limited (*)	
$T_{stg}$	Storage Temperature Range	- 40 to 150	°C
$T_{op}$	Operating Junction Temperature Range	- 40 to 125	°C

(\*) Our SO-8 package used for Voltage Regulators is modified internally to have pins 2, 3, 6 and 7 electrically commoned to the die attach flag. This particular frame decreases the total thermal resistance of the package and increases its ability to dissipate power when an appropriate area of copper on the printed circuit board is available for heatsinking. The external dimensions are the same as for the standard SO-8

## TEST CIRCUITS

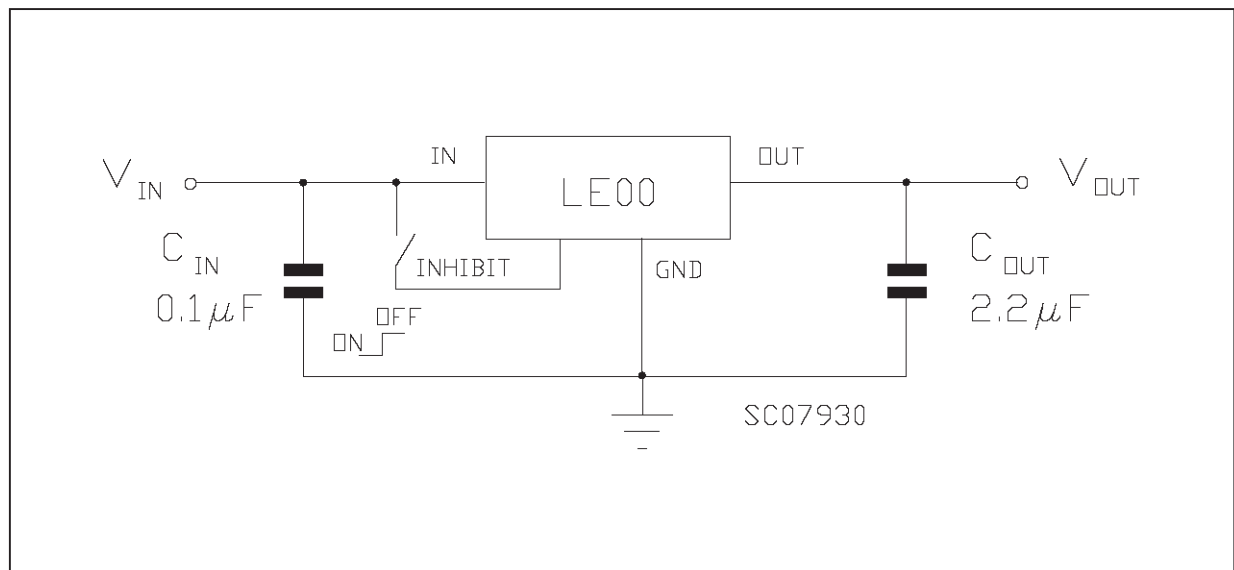

Note: If the Inhibit pin is left floating, the regulator is in ON mode. However, to avoid any noise picking-up, it is suggested to ground it when

## CONNECTION DIAGRAM AND ORDERING NUMBERS (top view)

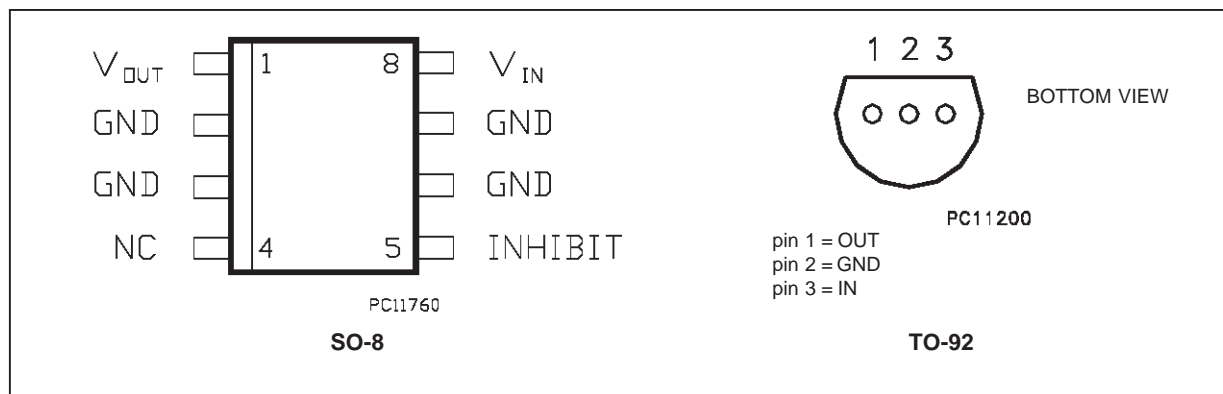

## ORDERING NUMBERS

Type	SO-8	TO-92	Output Voltage
LE12AB	LE12ABD	LE12ABZ	1.25 V
LE12C	LE12CD	LE12CZ	1.25 V
LE15AB	LE15ABD	LE15ABZ	1.5 V
LE15C	LE15CD	LE15CZ	1.5 V
LE25AB	LE25ABD	LE25ABZ	2.5 V
LE25C	LE25CD	LE25CZ	2.5 V
LE27AB	LE27ABD	LE27ABZ	2.7 V
LE27C	LE27CD	LE27CZ	2.7 V
LE30AB	LE30ABD	LE30ABZ	3 V
LE30C	LE30CD	LE30CZ	3 V
LE33AB	LE33ABD	LE33ABZ	3.3 V
LE33C	LE33CD	LE33CZ	3.3 V
LE35AB	LE35ABD	LE35ABZ	3.5 V
LE35C	LE35CD	LE35CZ	3.5 V
LE40AB	LE40ABD	LE40ABZ	4 V
LE40C	LE40CD	LE40CZ	4 V
LE45AB	LE45ABD	LE45ABZ	4.5 V
LE45C	LE45CD	LE45CZ	4.5 V
LE47AB	LE47ABD	LE47ABZ	4.7 V
LE47C	LE47CD	LE47CZ	4.7 V
LE50AB	LE50ABD	LE50ABZ	5 V
LE50C	LE50CD	LE50CZ	5 V
LE52AB	LE52ABD	LE52ABZ	5.2 V
LE52C	LE52CD	LE52CZ	5.2 V
LE55AB	LE55ABD	LE55ABZ	5.5 V
LE55C	LE55CD	LE55CZ	5.5 V
LE60AB (*)	LE60ABD	LE60ABZ	6 V
LE60C (*)	LE60CD	LE60CZ	6 V
LE80AB (*)	LE80ABD	LE80ABZ	8 V
LE80C (*)	LE80CD	LE80CZ	8 V
LE120AB (*)	LE120ABD	LE120ABZ	12 V
LE120C (*)	LE120CD	LE120CZ	12 V

(\*) Available on request

## LE00AB/C

**ELECTRICAL CHARACTERISTICS FOR LE12AB** (refer to the test circuits,  $T_j = 25\text{ }^\circ\text{C}$ ,  
 $C_i = 0.1\text{ }\mu\text{F}$ ,  $C_o = 2.2\text{ }\mu\text{F}$  unless otherwise specified)

Symbol	Parameter	Test Conditions	Min.	Typ.	Max.	Unit
$V_o$	Output Voltage	$I_o = 10\text{ mA}$ , $V_i = 3.3\text{ V}$	1.225	1.25	1.275	V
		$I_o = 10\text{ mA}$ , $V_i = 3.3\text{ V}$ $-25 < T_a < 85\text{ }^\circ\text{C}$	1.2		1.3	V
$V_i$	Operating Input Voltage	$I_o = 100\text{ mA}$	2.5		18	V
$I_{out}$	Output Current Limit		150			mA
$\Delta V_o$	Line Regulation	$V_i = 2.5\text{ to }18\text{ V}$ , $I_o = 0.5\text{ mA}$		3	15	mV
$\Delta V_o$	Load Regulation	$V_i = 2.8\text{ V}$ $I_o = 0.5\text{ to }100\text{ mA}$		3	15	mV
$I_d$	Quiescent Current	ON MODE				
		$V_i = 2.5\text{ to }18\text{ V}$ $I_o = 0\text{ mA}$		0.5	1	mA
		$V_i = 2.5\text{ to }18\text{ V}$ $I_o = 100\text{ mA}$		1.5	3	mA
		OFF MODE $V_i = 6\text{ V}$		50	100	$\mu\text{A}$
SVR	Supply Voltage Rejection	$I_o = 5\text{ mA}$ $V_i = 3.5\text{ V} \pm 1\text{ V}$				
		$f = 120\text{ Hz}$		82		dB
		$f = 1\text{ KHz}$		77		dB
		$f = 10\text{ KHz}$		60		dB
eN	Output Noise Voltage	$B = 10\text{ Hz to }100\text{ KHz}$		50		$\mu\text{V}$
$V_d$	Dropout Voltage	$I_o = 100\text{ mA}$ $-40 < T_a < 125\text{ }^\circ\text{C}$		1.25		V
$V_{il}$	Control Input Logic Low	$-40 < T_a < 125\text{ }^\circ\text{C}$			0.8	V
$V_{ih}$	Control Input Logic High	$-40 < T_a < 125\text{ }^\circ\text{C}$	2			V
$I_i$	Control Input Current	$V_i = 6\text{ V}$ , $V_c = 6\text{ V}$		10		$\mu\text{A}$
$C_o$	Output Bypass Capacitance	$\text{ESR} = 0.1\text{ to }10\text{ }\Omega$ $I_o = 0\text{ to }100\text{ mA}$	2	10		$\mu\text{F}$

**ELECTRICAL CHARACTERISTICS FOR LE12C** (refer to the test circuits,  $T_j = 25\text{ }^\circ\text{C}$ ,  
 $C_i = 0.1\text{ }\mu\text{F}$ ,  $C_o = 2.2\text{ }\mu\text{F}$  unless otherwise specified)

Symbol	Parameter	Test Conditions	Min.	Typ.	Max.	Unit
$V_o$	Output Voltage	$I_o = 10\text{ mA}$ , $V_i = 3.3\text{ V}$	1.225	1.25	1.275	V
		$I_o = 10\text{ mA}$ , $V_i = 3.3\text{ V}$ $-25 < T_a < 85\text{ }^\circ\text{C}$	1.2		1.3	V
$V_i$	Operating Input Voltage	$I_o = 100\text{ mA}$	2.5		18	V
$I_{out}$	Output Current Limit		150			mA
$\Delta V_o$	Line Regulation	$V_i = 2.5\text{ to }18\text{ V}$ , $I_o = 0.5\text{ mA}$		3	20	mV
$\Delta V_o$	Load Regulation	$V_i = 2.8\text{ V}$ $I_o = 0.5\text{ to }100\text{ mA}$		3	25	mV
$I_d$	Quiescent Current	ON MODE				
		$V_i = 2.5\text{ to }18\text{ V}$ $I_o = 0\text{ mA}$		0.5	1	mA
		$V_i = 2.5\text{ to }18\text{ V}$ $I_o = 100\text{ mA}$		1.5	3	mA
		OFF MODE $V_i = 6\text{ V}$		50	100	$\mu\text{A}$
SVR	Supply Voltage Rejection	$I_o = 5\text{ mA}$ $V_i = 3.5\text{ V} \pm 1\text{ V}$				
		$f = 120\text{ Hz}$		82		dB
		$f = 1\text{ KHz}$		77		dB
		$f = 10\text{ KHz}$		60		dB
eN	Output Noise Voltage	$B = 10\text{ Hz to }100\text{ KHz}$		50		$\mu\text{V}$
$V_d$	Dropout Voltage	$I_o = 100\text{ mA}$ $-40 < T_a < 125\text{ }^\circ\text{C}$		1.25		V
$V_{il}$	Control Input Logic Low	$-40 < T_a < 125\text{ }^\circ\text{C}$			0.8	V
$V_{ih}$	Control Input Logic High	$-40 < T_a < 125\text{ }^\circ\text{C}$	2			V
$I_i$	Control Input Current	$V_i = 6\text{ V}$ , $V_c = 6\text{ V}$		10		$\mu\text{A}$
$C_o$	Output Bypass Capacitance	$\text{ESR} = 0.1\text{ to }10\text{ }\Omega$ $I_o = 0\text{ to }100\text{ mA}$	2	10		$\mu\text{F}$

**ELECTRICAL CHARACTERISTICS FOR LE15AB** (refer to the test circuits,  $T_j = 25\text{ }^\circ\text{C}$ ,  
 $C_i = 0.1\text{ }\mu\text{F}$ ,  $C_o = 2.2\text{ }\mu\text{F}$  unless otherwise specified)

Symbol	Parameter	Test Conditions	Min.	Typ.	Max.	Unit
$V_o$	Output Voltage	$I_o = 10\text{ mA}$ , $V_i = 3.5\text{ V}$	1.47	1.5	1.53	V
		$I_o = 10\text{ mA}$ , $V_i = 3.5\text{ V}$ - $25 < T_a < 85\text{ }^\circ\text{C}$	1.44		1.56	V
$V_i$	Operating Input Voltage	$I_o = 100\text{ mA}$	2.5		18	V
$I_{out}$	Output Current Limit		150			mA
$\Delta V_o$	Line Regulation	$V_i = 2.5\text{ to }18\text{ V}$ , $I_o = 0.5\text{ mA}$		3	15	mV
$\Delta V_o$	Load Regulation	$V_i = 2.8\text{ V}$ $I_o = 0.5\text{ to }100\text{ mA}$		3	15	mV
$I_d$	Quiescent Current	ON MODE				
		$V_i = 2.5\text{ to }18\text{ V}$ $I_o = 0\text{ mA}$		0.5	1	mA
		$V_i = 2.5\text{ to }18\text{ V}$ $I_o = 100\text{ mA}$		1.5	3	mA
		OFF MODE $V_i = 6\text{ V}$		50	100	$\mu\text{A}$
SVR	Supply Voltage Rejection	$I_o = 5\text{ mA}$ $V_i = 3.5\text{ V} \pm 1\text{ V}$				
		$f = 120\text{ Hz}$		82		dB
		$f = 1\text{ KHz}$		77		dB
		$f = 10\text{ KHz}$		60		dB
eN	Output Noise Voltage	$B = 10\text{ Hz to }100\text{ KHz}$		50		$\mu\text{V}$
$V_d$	Dropout Voltage	$I_o = 100\text{ mA}$ $-40 < T_a < 125\text{ }^\circ\text{C}$		1		V
$V_{il}$	Control Input Logic Low	$-40 < T_a < 125\text{ }^\circ\text{C}$			0.8	V
$V_{ih}$	Control Input Logic High	$-40 < T_a < 125\text{ }^\circ\text{C}$	2			V
$I_i$	Control Input Current	$V_i = 6\text{ V}$ , $V_c = 6\text{ V}$		10		$\mu\text{A}$
$C_o$	Output Bypass Capacitance	$\text{ESR} = 0.1\text{ to }10\text{ }\Omega$ $I_o = 0\text{ to }100\text{ mA}$	2	10		$\mu\text{F}$

**ELECTRICAL CHARACTERISTICS FOR LE15C** (refer to the test circuits,  $T_j = 25\text{ }^\circ\text{C}$ ,  
 $C_i = 0.1\text{ }\mu\text{F}$ ,  $C_o = 2.2\text{ }\mu\text{F}$  unless otherwise specified)

Symbol	Parameter	Test Conditions	Min.	Typ.	Max.	Unit
$V_o$	Output Voltage	$I_o = 10\text{ mA}$ , $V_i = 3.5\text{ V}$	1.47	1.5	1.53	V
		$I_o = 10\text{ mA}$ , $V_i = 3.5\text{ V}$ - $25 < T_a < 85\text{ }^\circ\text{C}$	1.44		1.56	V
$V_i$	Operating Input Voltage	$I_o = 100\text{ mA}$	2.5		18	V
$I_{out}$	Output Current Limit		150			mA
$\Delta V_o$	Line Regulation	$V_i = 2.5\text{ to }18\text{ V}$ , $I_o = 0.5\text{ mA}$		3	20	mV
$\Delta V_o$	Load Regulation	$V_i = 2.8\text{ V}$ $I_o = 0.5\text{ to }100\text{ mA}$		3	25	mV
$I_d$	Quiescent Current	ON MODE				
		$V_i = 2.5\text{ to }18\text{ V}$ $I_o = 0\text{ mA}$		0.5	1	mA
		$V_i = 2.5\text{ to }18\text{ V}$ $I_o = 100\text{ mA}$		1.5	3	mA
		OFF MODE $V_i = 6\text{ V}$		50	100	$\mu\text{A}$
SVR	Supply Voltage Rejection	$I_o = 5\text{ mA}$ $V_i = 3.5\text{ V} \pm 1\text{ V}$				
		$f = 120\text{ Hz}$		82		dB
		$f = 1\text{ KHz}$		77		dB
		$f = 10\text{ KHz}$		60		dB
eN	Output Noise Voltage	$B = 10\text{ Hz to }100\text{ KHz}$		50		$\mu\text{V}$
$V_d$	Dropout Voltage	$I_o = 100\text{ mA}$ $-40 < T_a < 125\text{ }^\circ\text{C}$		1		V
$V_{il}$	Control Input Logic Low	$-40 < T_a < 125\text{ }^\circ\text{C}$			0.8	V
$V_{ih}$	Control Input Logic High	$-40 < T_a < 125\text{ }^\circ\text{C}$	2			V
$I_i$	Control Input Current	$V_i = 6\text{ V}$ , $V_c = 6\text{ V}$		10		$\mu\text{A}$
$C_o$	Output Bypass Capacitance	$\text{ESR} = 0.1\text{ to }10\text{ }\Omega$ $I_o = 0\text{ to }100\text{ mA}$	2	10		$\mu\text{F}$

## LE00AB/C

**ELECTRICAL CHARACTERISTICS FOR LE25AB** (refer to the test circuits,  $T_j = 25\text{ }^\circ\text{C}$ ,  
 $C_i = 0.1\text{ }\mu\text{F}$ ,  $C_o = 2.2\text{ }\mu\text{F}$  unless otherwise specified)

Symbol	Parameter	Test Conditions	Min.	Typ.	Max.	Unit	
$V_o$	Output Voltage	$I_o = 10\text{ mA}$ , $V_i = 4.5\text{ V}$	2.475	2.5	2.525	V	
		$I_o = 10\text{ mA}$ , $V_i = 4.5\text{ V}$ -25< $T_a$ <85 °C	2.45		2.55	V	
$V_i$	Operating Input Voltage	$I_o = 100\text{ mA}$			18	V	
$I_{out}$	Output Current Limit		150			mA	
$\Delta V_o$	Line Regulation	$V_i = 3.2\text{ to }18\text{ V}$ , $I_o = 0.5\text{ mA}$		3	15	mV	
$\Delta V_o$	Load Regulation	$V_i = 3.5\text{ V}$ $I_o = 0.5\text{ to }100\text{ mA}$		3	15	mV	
$I_d$	Quiescent Current	ON MODE					
		$V_i = 3.5\text{ to }18\text{ V}$ $I_o = 0\text{ mA}$		0.5	1	mA	
		$V_i = 3.5\text{ to }18\text{ V}$ $I_o = 100\text{ mA}$		1.5	3	mA	
	OFF MODE $V_i = 6\text{ V}$		50	100	$\mu\text{A}$		
SVR	Supply Voltage Rejection	$I_o = 5\text{ mA}$ $V_i = 4.5\text{ V} \pm 1\text{ V}$ $f = 120\text{ Hz}$ $f = 1\text{ KHz}$ $f = 10\text{ KHz}$		82		dB	
					77		dB
					60		dB
eN	Output Noise Voltage	$B = 10\text{ Hz to }100\text{ KHz}$		50		$\mu\text{V}$	
$V_d$	Dropout Voltage	$I_o = 100\text{ mA}$		0.2	0.4	V	
		$I_o = 100\text{ mA}$ -40 < $T_a$ < 125 °C			0.5	V	
$V_{il}$	Control Input Logic Low	-40 < $T_a$ < 125 °C			0.8	V	
$V_{ih}$	Control Input Logic High	-40 < $T_a$ < 125 °C	2			V	
$I_i$	Control Input Current	$V_i = 6\text{ V}$ , $V_c = 6\text{ V}$		10		$\mu\text{A}$	
$C_o$	Output Bypass Capacitance	ESR = 0.1 to 10 $\Omega$ $I_o = 0\text{ to }100\text{ mA}$	2	10		$\mu\text{F}$	

**ELECTRICAL CHARACTERISTICS FOR LE25C** (refer to the test circuits,  $T_j = 25\text{ }^\circ\text{C}$ ,  
 $C_i = 0.1\text{ }\mu\text{F}$ ,  $C_o = 2.2\text{ }\mu\text{F}$  unless otherwise specified)

Symbol	Parameter	Test Conditions	Min.	Typ.	Max.	Unit	
$V_o$	Output Voltage	$I_o = 10\text{ mA}$ , $V_i = 3.3\text{ V}$	2.45	2.5	2.55	V	
		$I_o = 10\text{ mA}$ , $V_i = 3.3\text{ V}$ -25< $T_a$ <85 °C	2.4		2.6	V	
$V_i$	Operating Input Voltage	$I_o = 100\text{ mA}$			18	V	
$I_{out}$	Output Current Limit		150			mA	
$\Delta V_o$	Line Regulation	$V_i = 3.2\text{ to }18\text{ V}$ , $I_o = 0.5\text{ mA}$		3	20	mV	
$\Delta V_o$	Load Regulation	$V_i = 3.5\text{ V}$ $I_o = 0.5\text{ to }100\text{ mA}$		3	25	mV	
$I_d$	Quiescent Current	ON MODE					
		$V_i = 3.5\text{ to }18\text{ V}$ $I_o = 0\text{ mA}$		0.5	1	mA	
		$V_i = 3.5\text{ to }18\text{ V}$ $I_o = 100\text{ mA}$		1.5	3	mA	
	OFF MODE $V_i = 6\text{ V}$		50	100	$\mu\text{A}$		
SVR	Supply Voltage Rejection	$I_o = 5\text{ mA}$ $V_i = 4.5\text{ V} \pm 1\text{ V}$ $f = 120\text{ Hz}$ $f = 1\text{ KHz}$ $f = 10\text{ KHz}$		82		dB	
					77		dB
					60		dB
eN	Output Noise Voltage	$B = 10\text{ Hz to }100\text{ KHz}$		50		$\mu\text{V}$	
$V_d$	Dropout Voltage	$I_o = 100\text{ mA}$		0.2	0.4	V	
		$I_o = 100\text{ mA}$ -40 < $T_a$ < 125 °C			0.5	V	
$V_{il}$	Control Input Logic Low	-40 < $T_a$ < 125 °C			0.8	V	
$V_{ih}$	Control Input Logic High	-40 < $T_a$ < 125 °C	2			V	
$I_i$	Control Input Current	$V_i = 6\text{ V}$ , $V_c = 6\text{ V}$		10		$\mu\text{A}$	
$C_o$	Output Bypass Capacitance	ESR = 0.1 to 10 $\Omega$ $I_o = 0\text{ to }100\text{ mA}$	2	10		$\mu\text{F}$	

**ELECTRICAL CHARACTERISTICS FOR LE27AB** (refer to the test circuits,  $T_j = 25\text{ }^\circ\text{C}$ ,  
 $C_i = 0.1\text{ }\mu\text{F}$ ,  $C_o = 2.2\text{ }\mu\text{F}$  unless otherwise specified)

Symbol	Parameter	Test Conditions	Min.	Typ.	Max.	Unit	
$V_o$	Output Voltage	$I_o = 10\text{ mA}$ , $V_i = 4.7\text{ V}$	2.673	2.7	2.727	V	
		$I_o = 10\text{ mA}$ , $V_i = 4.7\text{ V}$ $-25 < T_a < 85\text{ }^\circ\text{C}$	2.646		2.754	V	
$V_i$	Operating Input Voltage	$I_o = 100\text{ mA}$			18	V	
$I_{out}$	Output Current Limit		150			mA	
$\Delta V_o$	Line Regulation	$V_i = 3.4\text{ to }18\text{ V}$ , $I_o = 0.5\text{ mA}$		3	15	mV	
$\Delta V_o$	Load Regulation	$V_i = 3.7\text{ V}$ $I_o = 0.5\text{ to }100\text{ mA}$		3	15	mV	
$I_d$	Quiescent Current	ON MODE					
		$V_i = 3.7\text{ to }18\text{ V}$ $I_o = 0\text{ mA}$		0.5	1	mA	
		$V_i = 3.7\text{ to }18\text{ V}$ $I_o = 100\text{ mA}$		1.5	3	mA	
	OFF MODE $V_i = 6\text{ V}$		50	100	$\mu\text{A}$		
SVR	Supply Voltage Rejection	$I_o = 5\text{ mA}$ $V_i = 4.7\text{ V} \pm 1\text{ V}$ $f = 120\text{ Hz}$ $f = 1\text{ KHz}$ $f = 10\text{ KHz}$		82		dB	
					77		dB
					60		dB
eN	Output Noise Voltage	$B = 10\text{ Hz to }100\text{ KHz}$		50		$\mu\text{V}$	
$V_d$	Dropout Voltage	$I_o = 100\text{ mA}$		0.2	0.4	V	
		$I_o = 100\text{ mA}$ $-40 < T_a < 125\text{ }^\circ\text{C}$			0.5	V	
$V_{il}$	Control Input Logic Low	$-40 < T_a < 125\text{ }^\circ\text{C}$			0.8	V	
$V_{ih}$	Control Input Logic High	$-40 < T_a < 125\text{ }^\circ\text{C}$	2			V	
$I_i$	Control Input Current	$V_i = 6\text{ V}$ , $V_c = 6\text{ V}$		10		$\mu\text{A}$	
$C_o$	Output Bypass Capacitance	$\text{ESR} = 0.1\text{ to }10\text{ }\Omega$ $I_o = 0\text{ to }100\text{ mA}$	2	10		$\mu\text{F}$	

**ELECTRICAL CHARACTERISTICS FOR LE27C** (refer to the test circuits,  $T_j = 25\text{ }^\circ\text{C}$ ,  
 $C_i = 0.1\text{ }\mu\text{F}$ ,  $C_o = 2.2\text{ }\mu\text{F}$  unless otherwise specified)

Symbol	Parameter	Test Conditions	Min.	Typ.	Max.	Unit	
$V_o$	Output Voltage	$I_o = 10\text{ mA}$ , $V_i = 4.7\text{ V}$	2.646	2.7	2.754	V	
		$I_o = 10\text{ mA}$ , $V_i = 4.7\text{ V}$ $-25 < T_a < 85\text{ }^\circ\text{C}$	2.592		2.808	V	
$V_i$	Operating Input Voltage	$I_o = 100\text{ mA}$			18	V	
$I_{out}$	Output Current Limit		150			mA	
$\Delta V_o$	Line Regulation	$V_i = 3.4\text{ to }18\text{ V}$ , $I_o = 0.5\text{ mA}$		3	20	mV	
$\Delta V_o$	Load Regulation	$V_i = 3.7\text{ V}$ $I_o = 0.5\text{ to }100\text{ mA}$		3	25	mV	
$I_d$	Quiescent Current	ON MODE					
		$V_i = 3.7\text{ to }18\text{ V}$ $I_o = 0\text{ mA}$		0.5	1	mA	
		$V_i = 3.7\text{ to }18\text{ V}$ $I_o = 100\text{ mA}$		1.5	3	mA	
	OFF MODE $V_i = 6\text{ V}$		50	100	$\mu\text{A}$		
SVR	Supply Voltage Rejection	$I_o = 5\text{ mA}$ $V_i = 4.7\text{ V} \pm 1\text{ V}$ $f = 120\text{ Hz}$ $f = 1\text{ KHz}$ $f = 10\text{ KHz}$		82		dB	
					77		dB
					60		dB
eN	Output Noise Voltage	$B = 10\text{ Hz to }100\text{ KHz}$		50		$\mu\text{V}$	
$V_d$	Dropout Voltage	$I_o = 100\text{ mA}$		0.2	0.4	V	
		$I_o = 100\text{ mA}$ $-40 < T_a < 125\text{ }^\circ\text{C}$			0.5	V	
$V_{il}$	Control Input Logic Low	$-40 < T_a < 125\text{ }^\circ\text{C}$			0.8	V	
$V_{ih}$	Control Input Logic High	$-40 < T_a < 125\text{ }^\circ\text{C}$	2			V	
$I_i$	Control Input Current	$V_i = 6\text{ V}$ , $V_c = 6\text{ V}$		10		$\mu\text{A}$	
$C_o$	Output Bypass Capacitance	$\text{ESR} = 0.1\text{ to }10\text{ }\Omega$ $I_o = 0\text{ to }100\text{ mA}$	2	10		$\mu\text{F}$	

## LE00AB/C

**ELECTRICAL CHARACTERISTICS FOR LE30AB** (refer to the test circuits,  $T_j = 25\text{ }^\circ\text{C}$ ,  
 $C_i = 0.1\text{ }\mu\text{F}$ ,  $C_o = 2.2\text{ }\mu\text{F}$  unless otherwise specified)

Symbol	Parameter	Test Conditions	Min.	Typ.	Max.	Unit	
$V_o$	Output Voltage	$I_o = 10\text{ mA}$ , $V_i = 5\text{ V}$	2.970	3	3.030	V	
		$I_o = 10\text{ mA}$ , $V_i = 5\text{ V}$ $-25 < T_a < 85\text{ }^\circ\text{C}$	2.940		3.060	V	
$V_i$	Operating Input Voltage	$I_o = 100\text{ mA}$			18	V	
$I_{out}$	Output Current Limit		150			mA	
$\Delta V_o$	Line Regulation	$V_i = 3.7\text{ to }18\text{ V}$ , $I_o = 0.5\text{ mA}$		3	15	mV	
$\Delta V_o$	Load Regulation	$V_i = 4\text{ V}$ $I_o = 0.5\text{ to }100\text{ mA}$		3	15	mV	
$I_d$	Quiescent Current	ON MODE					
		$V_i = 4\text{ to }18\text{ V}$ $I_o = 0\text{ mA}$		0.5	1	mA	
		$V_i = 4\text{ to }18\text{ V}$ $I_o = 100\text{ mA}$		1.5	3	mA	
	OFF MODE $V_i = 6\text{ V}$		50	100	$\mu\text{A}$		
SVR	Supply Voltage Rejection	$I_o = 5\text{ mA}$ $V_i = 5\text{ V} \pm 1\text{ V}$ $f = 120\text{ Hz}$ $f = 1\text{ KHz}$ $f = 10\text{ KHz}$		81		dB	
					76		dB
					60		dB
eN	Output Noise Voltage	$B = 10\text{ Hz to }100\text{ KHz}$		50		$\mu\text{V}$	
$V_d$	Dropout Voltage	$I_o = 100\text{ mA}$		0.2	0.4	V	
		$I_o = 100\text{ mA}$ $-40 < T_a < 125\text{ }^\circ\text{C}$			0.5	V	
$V_{il}$	Control Input Logic Low	$-40 < T_a < 125\text{ }^\circ\text{C}$			0.8	V	
$V_{ih}$	Control Input Logic High	$-40 < T_a < 125\text{ }^\circ\text{C}$	2			V	
$I_i$	Control Input Current	$V_i = 6\text{ V}$ , $V_c = 6\text{ V}$		10		$\mu\text{A}$	
$C_o$	Output Bypass Capacitance	$\text{ESR} = 0.1\text{ to }10\text{ }\Omega$ $I_o = 0\text{ to }100\text{ mA}$	2	10		$\mu\text{F}$	

**ELECTRICAL CHARACTERISTICS FOR LE30C** (refer to the test circuits,  $T_j = 25\text{ }^\circ\text{C}$ ,  
 $C_i = 0.1\text{ }\mu\text{F}$ ,  $C_o = 2.2\text{ }\mu\text{F}$  unless otherwise specified)

Symbol	Parameter	Test Conditions	Min.	Typ.	Max.	Unit	
$V_o$	Output Voltage	$I_o = 10\text{ mA}$ , $V_i = 5\text{ V}$	2.940	3	3.060	V	
		$I_o = 10\text{ mA}$ , $V_i = 5\text{ V}$ $-25 < T_a < 85\text{ }^\circ\text{C}$	2.880		3.120	V	
$V_i$	Operating Input Voltage	$I_o = 100\text{ mA}$			18	V	
$I_{out}$	Output Current Limit		150			mA	
$\Delta V_o$	Line Regulation	$V_i = 3.7\text{ to }18\text{ V}$ , $I_o = 0.5\text{ mA}$		3	20	mV	
$\Delta V_o$	Load Regulation	$V_i = 4\text{ V}$ $I_o = 0.5\text{ to }100\text{ mA}$		3	25	mV	
$I_d$	Quiescent Current	ON MODE					
		$V_i = 4\text{ to }18\text{ V}$ $I_o = 0\text{ mA}$		0.5	1	mA	
		$V_i = 4\text{ to }18\text{ V}$ $I_o = 100\text{ mA}$		1.5	3	mA	
	OFF MODE $V_i = 6\text{ V}$		50	100	$\mu\text{A}$		
SVR	Supply Voltage Rejection	$I_o = 5\text{ mA}$ $V_i = 5\text{ V} \pm 1\text{ V}$ $f = 120\text{ Hz}$ $f = 1\text{ KHz}$ $f = 10\text{ KHz}$		81		dB	
					76		dB
					60		dB
eN	Output Noise Voltage	$B = 10\text{ Hz to }100\text{ KHz}$		50		$\mu\text{V}$	
$V_d$	Dropout Voltage	$I_o = 100\text{ mA}$		0.2	0.4	V	
		$I_o = 100\text{ mA}$ $-40 < T_a < 125\text{ }^\circ\text{C}$			0.5	V	
$V_{il}$	Control Input Logic Low	$-40 < T_a < 125\text{ }^\circ\text{C}$			0.8	V	
$V_{ih}$	Control Input Logic High	$-40 < T_a < 125\text{ }^\circ\text{C}$	2			V	
$I_i$	Control Input Current	$V_i = 6\text{ V}$ , $V_c = 6\text{ V}$		10		$\mu\text{A}$	
$C_o$	Output Bypass Capacitance	$\text{ESR} = 0.1\text{ to }10\text{ }\Omega$ $I_o = 0\text{ to }100\text{ mA}$	2	10		$\mu\text{F}$	



**ELECTRICAL CHARACTERISTICS FOR LE33AB** (refer to the test circuits,  $T_j = 25\text{ }^\circ\text{C}$ ,  
 $C_i = 0.1\text{ }\mu\text{F}$ ,  $C_o = 2.2\text{ }\mu\text{F}$  unless otherwise specified)

Symbol	Parameter	Test Conditions	Min.	Typ.	Max.	Unit
$V_o$	Output Voltage	$I_o = 10\text{ mA}$ , $V_i = 5.3\text{ V}$	3.267	3.3	3.333	V
		$I_o = 10\text{ mA}$ , $V_i = 5.3\text{ V}$ $-25 < T_a < 85\text{ }^\circ\text{C}$	3.234		3.366	V
$V_i$	Operating Input Voltage	$I_o = 100\text{ mA}$			18	V
$I_{out}$	Output Current Limit		150			mA
$\Delta V_o$	Line Regulation	$V_i = 4\text{ to }18\text{ V}$ , $I_o = 0.5\text{ mA}$		3	15	mV
$\Delta V_o$	Load Regulation	$V_i = 4.3\text{ V}$ $I_o = 0.5\text{ to }100\text{ mA}$		3	15	mV
$I_d$	Quiescent Current	ON MODE				
		$V_i = 4.3\text{ to }18\text{ V}$ $I_o = 0\text{ mA}$		0.5	1	mA
		$V_i = 4.3\text{ to }18\text{ V}$ $I_o = 100\text{ mA}$		1.5	3	mA
		OFF MODE $V_i = 6\text{ V}$		50	100	$\mu\text{A}$
SVR	Supply Voltage Rejection	$I_o = 5\text{ mA}$ $V_i = 5.3\text{ V} \pm 1\text{ V}$				
		$f = 120\text{ Hz}$		80		dB
		$f = 1\text{ KHz}$		75		dB
		$f = 10\text{ KHz}$		60		dB
eN	Output Noise Voltage	$B = 10\text{ Hz to }100\text{ KHz}$		50		$\mu\text{V}$
$V_d$	Dropout Voltage	$I_o = 100\text{ mA}$		0.2	0.4	V
		$I_o = 100\text{ mA}$ $-40 < T_a < 125\text{ }^\circ\text{C}$			0.5	V
$V_{il}$	Control Input Logic Low	$-40 < T_a < 125\text{ }^\circ\text{C}$			0.8	V
$V_{ih}$	Control Input Logic High	$-40 < T_a < 125\text{ }^\circ\text{C}$	2			V
$I_i$	Control Input Current	$V_i = 6\text{ V}$ , $V_c = 6\text{ V}$		10		$\mu\text{A}$
$C_o$	Output Bypass Capacitance	$\text{ESR} = 0.1\text{ to }10\text{ }\Omega$ $I_o = 0\text{ to }100\text{ mA}$	2	10		$\mu\text{F}$

**ELECTRICAL CHARACTERISTICS FOR LE33C** (refer to the test circuits,  $T_j = 25\text{ }^\circ\text{C}$ ,  
 $C_i = 0.1\text{ }\mu\text{F}$ ,  $C_o = 2.2\text{ }\mu\text{F}$  unless otherwise specified)

Symbol	Parameter	Test Conditions	Min.	Typ.	Max.	Unit
$V_o$	Output Voltage	$I_o = 10\text{ mA}$ , $V_i = 5.3\text{ V}$	3.234	3.3	3.366	V
		$I_o = 10\text{ mA}$ , $V_i = 5.3\text{ V}$ $-25 < T_a < 85\text{ }^\circ\text{C}$	3.168		3.432	V
$V_i$	Operating Input Voltage	$I_o = 100\text{ mA}$			18	V
$I_{out}$	Output Current Limit		150			mA
$\Delta V_o$	Line Regulation	$V_i = 4\text{ to }18\text{ V}$ , $I_o = 0.5\text{ mA}$		3	20	mV
$\Delta V_o$	Load Regulation	$V_i = 4.3\text{ V}$ $I_o = 0.5\text{ to }100\text{ mA}$		3	25	mV
$I_d$	Quiescent Current	ON MODE				
		$V_i = 4.3\text{ to }18\text{ V}$ $I_o = 0\text{ mA}$		0.5	1	mA
		$V_i = 4.3\text{ to }18\text{ V}$ $I_o = 100\text{ mA}$		1.5	3	mA
		OFF MODE $V_i = 6\text{ V}$		50	100	$\mu\text{A}$
SVR	Supply Voltage Rejection	$I_o = 5\text{ mA}$ $V_i = 5.3\text{ V} \pm 1\text{ V}$				
		$f = 120\text{ Hz}$		80		dB
		$f = 1\text{ KHz}$		75		dB
		$f = 10\text{ KHz}$		60		dB
eN	Output Noise Voltage	$B = 10\text{ Hz to }100\text{ KHz}$		50		$\mu\text{V}$
$V_d$	Dropout Voltage	$I_o = 100\text{ mA}$		0.2	0.4	V
		$I_o = 100\text{ mA}$ $-40 < T_a < 125\text{ }^\circ\text{C}$			0.5	V
$V_{il}$	Control Input Logic Low	$-40 < T_a < 125\text{ }^\circ\text{C}$			0.8	V
$V_{ih}$	Control Input Logic High	$-40 < T_a < 125\text{ }^\circ\text{C}$	2			V
$I_i$	Control Input Current	$V_i = 6\text{ V}$ , $V_c = 6\text{ V}$		10		$\mu\text{A}$
$C_o$	Output Bypass Capacitance	$\text{ESR} = 0.1\text{ to }10\text{ }\Omega$ $I_o = 0\text{ to }100\text{ mA}$	2	10		$\mu\text{F}$

## LE00AB/C

**ELECTRICAL CHARACTERISTICS FOR LE35AB** (refer to the test circuits,  $T_j = 25\text{ }^\circ\text{C}$ ,  
 $C_i = 0.1\text{ }\mu\text{F}$ ,  $C_o = 2.2\text{ }\mu\text{F}$  unless otherwise specified)

Symbol	Parameter	Test Conditions	Min.	Typ.	Max.	Unit	
$V_o$	Output Voltage	$I_o = 10\text{ mA}$ , $V_i = 5.5\text{ V}$	3.465	3.5	3.535	V	
		$I_o = 10\text{ mA}$ , $V_i = 5.5\text{ V}$ - $25 < T_a < 85\text{ }^\circ\text{C}$	3.43		3.57	V	
$V_i$	Operating Input Voltage	$I_o = 100\text{ mA}$			18	V	
$I_{out}$	Output Current Limit		150			mA	
$\Delta V_o$	Line Regulation	$V_i = 4.2\text{ to }18\text{ V}$ , $I_o = 0.5\text{ mA}$		3	15	mV	
$\Delta V_o$	Load Regulation	$V_i = 4.5\text{ V}$ $I_o = 0.5\text{ to }100\text{ mA}$		3	15	mV	
$I_d$	Quiescent Current	ON MODE					
		$V_i = 4.5\text{ to }18\text{ V}$ $I_o = 0\text{ mA}$		0.5	1	mA	
		$V_i = 4.5\text{ to }18\text{ V}$ $I_o = 100\text{ mA}$		1.5	3	mA	
	OFF MODE $V_i = 6\text{ V}$		50	100	$\mu\text{A}$		
SVR	Supply Voltage Rejection	$I_o = 5\text{ mA}$ $V_i = 5.5\text{ V} \pm 1\text{ V}$ $f = 120\text{ Hz}$ $f = 1\text{ KHz}$ $f = 10\text{ KHz}$		79		dB	
					74		dB
					60		dB
eN	Output Noise Voltage	$B = 10\text{ Hz to }100\text{ KHz}$		50		$\mu\text{V}$	
$V_d$	Dropout Voltage	$I_o = 100\text{ mA}$		0.2	0.4	V	
		$I_o = 100\text{ mA}$ $-40 < T_a < 125\text{ }^\circ\text{C}$			0.5	V	
$V_{il}$	Control Input Logic Low	$-40 < T_a < 125\text{ }^\circ\text{C}$			0.8	V	
$V_{ih}$	Control Input Logic High	$-40 < T_a < 125\text{ }^\circ\text{C}$	2			V	
$I_i$	Control Input Current	$V_i = 6\text{ V}$ , $V_c = 6\text{ V}$		10		$\mu\text{A}$	
$C_o$	Output Bypass Capacitance	$\text{ESR} = 0.1\text{ to }10\text{ }\Omega$ $I_o = 0\text{ to }100\text{ mA}$	2	10		$\mu\text{F}$	

**ELECTRICAL CHARACTERISTICS FOR LE35C** (refer to the test circuits,  $T_j = 25\text{ }^\circ\text{C}$ ,  
 $C_i = 0.1\text{ }\mu\text{F}$ ,  $C_o = 2.2\text{ }\mu\text{F}$  unless otherwise specified)

Symbol	Parameter	Test Conditions	Min.	Typ.	Max.	Unit	
$V_o$	Output Voltage	$I_o = 10\text{ mA}$ , $V_i = 5.5\text{ V}$	3.43	3.5	3.57	V	
		$I_o = 10\text{ mA}$ , $V_i = 5.5\text{ V}$ - $25 < T_a < 85\text{ }^\circ\text{C}$	3.36		3.64	V	
$V_i$	Operating Input Voltage	$I_o = 100\text{ mA}$			18	V	
$I_{out}$	Output Current Limit		150			mA	
$\Delta V_o$	Line Regulation	$V_i = 4.2\text{ to }18\text{ V}$ , $I_o = 0.5\text{ mA}$		3	20	mV	
$\Delta V_o$	Load Regulation	$V_i = 4.5\text{ V}$ $I_o = 0.5\text{ to }100\text{ mA}$		3	25	mV	
$I_d$	Quiescent Current	ON MODE					
		$V_i = 4.5\text{ to }18\text{ V}$ $I_o = 0\text{ mA}$		0.5	1	mA	
		$V_i = 4.5\text{ to }18\text{ V}$ $I_o = 100\text{ mA}$		1.5	3	mA	
	OFF MODE $V_i = 6\text{ V}$		50	100	$\mu\text{A}$		
SVR	Supply Voltage Rejection	$I_o = 5\text{ mA}$ $V_i = 5.5\text{ V} \pm 1\text{ V}$ $f = 120\text{ Hz}$ $f = 1\text{ KHz}$ $f = 10\text{ KHz}$		79		dB	
					74		dB
					60		dB
eN	Output Noise Voltage	$B = 10\text{ Hz to }100\text{ KHz}$		50		$\mu\text{V}$	
$V_d$	Dropout Voltage	$I_o = 100\text{ mA}$		0.2	0.4	V	
		$I_o = 100\text{ mA}$ $-40 < T_a < 125\text{ }^\circ\text{C}$			0.5	V	
$V_{il}$	Control Input Logic Low	$-40 < T_a < 125\text{ }^\circ\text{C}$			0.8	V	
$V_{ih}$	Control Input Logic High	$-40 < T_a < 125\text{ }^\circ\text{C}$	2			V	
$I_i$	Control Input Current	$V_i = 6\text{ V}$ , $V_c = 6\text{ V}$		10		$\mu\text{A}$	
$C_o$	Output Bypass Capacitance	$\text{ESR} = 0.1\text{ to }10\text{ }\Omega$ $I_o = 0\text{ to }100\text{ mA}$	2	10		$\mu\text{F}$	

**ELECTRICAL CHARACTERISTICS FOR LE40AB** (refer to the test circuits,  $T_j = 25\text{ }^\circ\text{C}$ ,  
 $C_i = 0.1\text{ }\mu\text{F}$ ,  $C_o = 2.2\text{ }\mu\text{F}$  unless otherwise specified)

Symbol	Parameter	Test Conditions	Min.	Typ.	Max.	Unit	
$V_o$	Output Voltage	$I_o = 10\text{ mA}$ , $V_i = 6\text{ V}$	3.96	4	4.04	V	
		$I_o = 10\text{ mA}$ , $V_i = 6\text{ V}$ $-25 < T_a < 85\text{ }^\circ\text{C}$	3.92		4.08	V	
$V_i$	Operating Input Voltage	$I_o = 100\text{ mA}$			18	V	
$I_{out}$	Output Current Limit		150			mA	
$\Delta V_o$	Line Regulation	$V_i = 4.7\text{ to }18\text{ V}$ , $I_o = 0.5\text{ mA}$		4	20	mV	
$\Delta V_o$	Load Regulation	$V_i = 5\text{ V}$ $I_o = 0.5\text{ to }100\text{ mA}$		3	15	mV	
$I_d$	Quiescent Current	ON MODE					
		$V_i = 5\text{ to }18\text{ V}$ $I_o = 0\text{ mA}$		0.5	1	mA	
		$V_i = 5\text{ to }18\text{ V}$ $I_o = 100\text{ mA}$		1.5	3	mA	
	OFF MODE $V_i = 6\text{ V}$		50	100	$\mu\text{A}$		
SVR	Supply Voltage Rejection	$I_o = 5\text{ mA}$ $V_i = 6\text{ V} \pm 1\text{ V}$ $f = 120\text{ Hz}$ $f = 1\text{ KHz}$ $f = 10\text{ KHz}$		78		dB	
					73		dB
					60		dB
eN	Output Noise Voltage	$B = 10\text{ Hz to }100\text{ KHz}$		50		$\mu\text{V}$	
$V_d$	Dropout Voltage	$I_o = 100\text{ mA}$		0.2	0.4	V	
		$I_o = 100\text{ mA}$ $-40 < T_a < 125\text{ }^\circ\text{C}$			0.5	V	
$V_{il}$	Control Input Logic Low	$-40 < T_a < 125\text{ }^\circ\text{C}$			0.8	V	
$V_{ih}$	Control Input Logic High	$-40 < T_a < 125\text{ }^\circ\text{C}$	2			V	
$I_i$	Control Input Current	$V_i = 6\text{ V}$ , $V_c = 6\text{ V}$		10		$\mu\text{A}$	
$C_o$	Output Bypass Capacitance	$\text{ESR} = 0.1\text{ to }10\text{ }\Omega$ $I_o = 0\text{ to }100\text{ mA}$	2	10		$\mu\text{F}$	

**ELECTRICAL CHARACTERISTICS FOR LE40C** (refer to the test circuits,  $T_j = 25\text{ }^\circ\text{C}$ ,  
 $C_i = 0.1\text{ }\mu\text{F}$ ,  $C_o = 2.2\text{ }\mu\text{F}$  unless otherwise specified)

Symbol	Parameter	Test Conditions	Min.	Typ.	Max.	Unit	
$V_o$	Output Voltage	$I_o = 10\text{ mA}$ , $V_i = 6\text{ V}$	3.92	4	4.08	V	
		$I_o = 10\text{ mA}$ , $V_i = 6\text{ V}$ $-25 < T_a < 85\text{ }^\circ\text{C}$	3.84		4.16	V	
$V_i$	Operating Input Voltage	$I_o = 100\text{ mA}$			18	V	
$I_{out}$	Output Current Limit		150			mA	
$\Delta V_o$	Line Regulation	$V_i = 4.7\text{ to }18\text{ V}$ , $I_o = 0.5\text{ mA}$		4	30	mV	
$\Delta V_o$	Load Regulation	$V_i = 5\text{ V}$ $I_o = 0.5\text{ to }100\text{ mA}$		3	25	mV	
$I_d$	Quiescent Current	ON MODE					
		$V_i = 5\text{ to }18\text{ V}$ $I_o = 0\text{ mA}$		0.5	1	mA	
		$V_i = 5\text{ to }18\text{ V}$ $I_o = 100\text{ mA}$		1.5	3	mA	
	OFF MODE $V_i = 6\text{ V}$		50	100	$\mu\text{A}$		
SVR	Supply Voltage Rejection	$I_o = 5\text{ mA}$ $V_i = 6\text{ V} \pm 1\text{ V}$ $f = 120\text{ Hz}$ $f = 1\text{ KHz}$ $f = 10\text{ KHz}$		78		dB	
					73		dB
					60		dB
eN	Output Noise Voltage	$B = 10\text{ Hz to }100\text{ KHz}$		50		$\mu\text{V}$	
$V_d$	Dropout Voltage	$I_o = 100\text{ mA}$		0.2	0.4	V	
		$I_o = 100\text{ mA}$ $-40 < T_a < 125\text{ }^\circ\text{C}$			0.5	V	
$V_{il}$	Control Input Logic Low	$-40 < T_a < 125\text{ }^\circ\text{C}$			0.8	V	
$V_{ih}$	Control Input Logic High	$-40 < T_a < 125\text{ }^\circ\text{C}$	2			V	
$I_i$	Control Input Current	$V_i = 6\text{ V}$ , $V_c = 6\text{ V}$		10		$\mu\text{A}$	
$C_o$	Output Bypass Capacitance	$\text{ESR} = 0.1\text{ to }10\text{ }\Omega$ $I_o = 0\text{ to }100\text{ mA}$	2	10		$\mu\text{F}$	

## LE00AB/C

**ELECTRICAL CHARACTERISTICS FOR LE45AB** (refer to the test circuits,  $T_j = 25\text{ }^\circ\text{C}$ ,  
 $C_i = 0.1\text{ }\mu\text{F}$ ,  $C_o = 2.2\text{ }\mu\text{F}$  unless otherwise specified)

Symbol	Parameter	Test Conditions	Min.	Typ.	Max.	Unit
$V_o$	Output Voltage	$I_o = 10\text{ mA}$ , $V_i = 6.5\text{ V}$	4.445	4.5	4.545	V
		$I_o = 10\text{ mA}$ , $V_i = 6.5\text{ V}$ $-25 < T_a < 85\text{ }^\circ\text{C}$	4.41		4.59	V
$V_i$	Operating Input Voltage	$I_o = 100\text{ mA}$			18	V
$I_{out}$	Output Current Limit		150			mA
$\Delta V_o$	Line Regulation	$V_i = 5.2\text{ to }18\text{ V}$ , $I_o = 0.5\text{ mA}$		4	20	mV
$\Delta V_o$	Load Regulation	$V_i = 5.5\text{ V}$ $I_o = 0.5\text{ to }100\text{ mA}$		3	15	mV
$I_d$	Quiescent Current	ON MODE				
		$V_i = 5.5\text{ to }18\text{ V}$ $I_o = 0\text{ mA}$		0.5	1	mA
		$V_i = 5.5\text{ to }18\text{ V}$ $I_o = 100\text{ mA}$		1.5	3	mA
	OFF MODE $V_i = 6\text{ V}$		50	100	$\mu\text{A}$	
SVR	Supply Voltage Rejection	$I_o = 5\text{ mA}$ $V_i = 6.5\text{ V} \pm 1\text{ V}$				
		$f = 120\text{ Hz}$		77		dB
		$f = 1\text{ KHz}$		72		dB
		$f = 10\text{ KHz}$		60		dB
eN	Output Noise Voltage	$B = 10\text{ Hz to }100\text{ KHz}$		50		$\mu\text{V}$
$V_d$	Dropout Voltage	$I_o = 100\text{ mA}$		0.2	0.4	V
		$I_o = 100\text{ mA}$ $-40 < T_a < 125\text{ }^\circ\text{C}$			0.5	V
$V_{il}$	Control Input Logic Low	$-40 < T_a < 125\text{ }^\circ\text{C}$			0.8	V
$V_{ih}$	Control Input Logic High	$-40 < T_a < 125\text{ }^\circ\text{C}$	2			V
$I_i$	Control Input Current	$V_i = 6\text{ V}$ , $V_c = 6\text{ V}$		10		$\mu\text{A}$
$C_o$	Output Bypass Capacitance	$\text{ESR} = 0.1\text{ to }10\text{ }\Omega$ $I_o = 0\text{ to }100\text{ mA}$	2	10		$\mu\text{F}$

**ELECTRICAL CHARACTERISTICS FOR LE45C** (refer to the test circuits,  $T_j = 25\text{ }^\circ\text{C}$ ,  
 $C_i = 0.1\text{ }\mu\text{F}$ ,  $C_o = 2.2\text{ }\mu\text{F}$  unless otherwise specified)

Symbol	Parameter	Test Conditions	Min.	Typ.	Max.	Unit
$V_o$	Output Voltage	$I_o = 10\text{ mA}$ , $V_i = 6.5\text{ V}$	4.41	4.5	4.59	V
		$I_o = 10\text{ mA}$ , $V_i = 6.5\text{ V}$ $-25 < T_a < 85\text{ }^\circ\text{C}$	4.32		4.68	V
$V_i$	Operating Input Voltage	$I_o = 100\text{ mA}$			18	V
$I_{out}$	Output Current Limit		150			mA
$\Delta V_o$	Line Regulation	$V_i = 5.2\text{ to }18\text{ V}$ , $I_o = 0.5\text{ mA}$		4	30	mV
$\Delta V_o$	Load Regulation	$V_i = 5.5\text{ V}$ $I_o = 0.5\text{ to }100\text{ mA}$		3	25	mV
$I_d$	Quiescent Current	ON MODE				
		$V_i = 5.5\text{ to }18\text{ V}$ $I_o = 0\text{ mA}$		0.5	1	mA
		$V_i = 5.5\text{ to }18\text{ V}$ $I_o = 100\text{ mA}$		1.5	3	mA
	OFF MODE $V_i = 6\text{ V}$		50	100	$\mu\text{A}$	
SVR	Supply Voltage Rejection	$I_o = 5\text{ mA}$ $V_i = 6.5\text{ V} \pm 1\text{ V}$				
		$f = 120\text{ Hz}$		77		dB
		$f = 1\text{ KHz}$		72		dB
		$f = 10\text{ KHz}$		60		dB
eN	Output Noise Voltage	$B = 10\text{ Hz to }100\text{ KHz}$		50		$\mu\text{V}$
$V_d$	Dropout Voltage	$I_o = 100\text{ mA}$		0.2	0.4	V
		$I_o = 100\text{ mA}$ $-40 < T_a < 125\text{ }^\circ\text{C}$			0.5	V
$V_{il}$	Control Input Logic Low	$-40 < T_a < 125\text{ }^\circ\text{C}$			0.8	V
$V_{ih}$	Control Input Logic High	$-40 < T_a < 125\text{ }^\circ\text{C}$	2			V
$I_i$	Control Input Current	$V_i = 6\text{ V}$ , $V_c = 6\text{ V}$		10		$\mu\text{A}$
$C_o$	Output Bypass Capacitance	$\text{ESR} = 0.1\text{ to }10\text{ }\Omega$ $I_o = 0\text{ to }100\text{ mA}$	2	10		$\mu\text{F}$

**ELECTRICAL CHARACTERISTICS FOR LE47AB** (refer to the test circuits,  $T_j = 25\text{ }^\circ\text{C}$ ,  
 $C_i = 0.1\text{ }\mu\text{F}$ ,  $C_o = 2.2\text{ }\mu\text{F}$  unless otherwise specified)

Symbol	Parameter	Test Conditions	Min.	Typ.	Max.	Unit	
$V_o$	Output Voltage	$I_o = 10\text{ mA}$ , $V_i = 6.7\text{ V}$	4.653	4.7	4.747	V	
		$I_o = 10\text{ mA}$ , $V_i = 6.7\text{ V}$ - $25 < T_a < 85\text{ }^\circ\text{C}$	4.606		4.794	V	
$V_i$	Operating Input Voltage	$I_o = 100\text{ mA}$			18	V	
$I_{out}$	Output Current Limit		150			mA	
$\Delta V_o$	Line Regulation	$V_i = 5.4\text{ to }18\text{ V}$ , $I_o = 0.5\text{ mA}$		4	20	mV	
$\Delta V_o$	Load Regulation	$V_i = 5.7\text{ V}$ $I_o = 0.5\text{ to }100\text{ mA}$		3	15	mV	
$I_d$	Quiescent Current	ON MODE					
		$V_i = 5.7\text{ to }18\text{ V}$ $I_o = 0\text{ mA}$		0.5	1	mA	
		$V_i = 5.7\text{ to }18\text{ V}$ $I_o = 100\text{ mA}$		1.5	3	mA	
	OFF MODE $V_i = 6\text{ V}$		50	100	$\mu\text{A}$		
SVR	Supply Voltage Rejection	$I_o = 5\text{ mA}$ $V_i = 6.7\text{ V} \pm 1\text{ V}$ $f = 120\text{ Hz}$ $f = 1\text{ KHz}$ $f = 10\text{ KHz}$		77		dB	
					72		dB
					60		dB
eN	Output Noise Voltage	$B = 10\text{ Hz to }100\text{ KHz}$		50		$\mu\text{V}$	
$V_d$	Dropout Voltage	$I_o = 100\text{ mA}$		0.2	0.4	V	
		$I_o = 100\text{ mA}$ $-40 < T_a < 125\text{ }^\circ\text{C}$			0.5	V	
$V_{il}$	Control Input Logic Low	$-40 < T_a < 125\text{ }^\circ\text{C}$			0.8	V	
$V_{ih}$	Control Input Logic High	$-40 < T_a < 125\text{ }^\circ\text{C}$	2			V	
$I_i$	Control Input Current	$V_i = 6\text{ V}$ , $V_c = 6\text{ V}$		10		$\mu\text{A}$	
$C_o$	Output Bypass Capacitance	$\text{ESR} = 0.1\text{ to }10\text{ }\Omega$ $I_o = 0\text{ to }100\text{ mA}$	2	10		$\mu\text{F}$	

**ELECTRICAL CHARACTERISTICS FOR LE47C** (refer to the test circuits,  $T_j = 25\text{ }^\circ\text{C}$ ,  
 $C_i = 0.1\text{ }\mu\text{F}$ ,  $C_o = 2.2\text{ }\mu\text{F}$  unless otherwise specified)

Symbol	Parameter	Test Conditions	Min.	Typ.	Max.	Unit	
$V_o$	Output Voltage	$I_o = 10\text{ mA}$ , $V_i = 6.7\text{ V}$	4.606	4.7	4.794	V	
		$I_o = 10\text{ mA}$ , $V_i = 6.7\text{ V}$ - $25 < T_a < 85\text{ }^\circ\text{C}$	4.512		4.888	V	
$V_i$	Operating Input Voltage	$I_o = 100\text{ mA}$			18	V	
$I_{out}$	Output Current Limit		150			mA	
$\Delta V_o$	Line Regulation	$V_i = 5.4\text{ to }18\text{ V}$ , $I_o = 0.5\text{ mA}$		4	30	mV	
$\Delta V_o$	Load Regulation	$V_i = 5.7\text{ V}$ $I_o = 0.5\text{ to }100\text{ mA}$		3	25	mV	
$I_d$	Quiescent Current	ON MODE					
		$V_i = 5.7\text{ to }18\text{ V}$ $I_o = 0\text{ mA}$		0.5	1	mA	
		$V_i = 5.7\text{ to }18\text{ V}$ $I_o = 100\text{ mA}$		1.5	3	mA	
	OFF MODE $V_i = 6\text{ V}$		50	100	$\mu\text{A}$		
SVR	Supply Voltage Rejection	$I_o = 5\text{ mA}$ $V_i = 6.7\text{ V} \pm 1\text{ V}$ $f = 120\text{ Hz}$ $f = 1\text{ KHz}$ $f = 10\text{ KHz}$		77		dB	
					72		dB
					60		dB
eN	Output Noise Voltage	$B = 10\text{ Hz to }100\text{ KHz}$		50		$\mu\text{V}$	
$V_d$	Dropout Voltage	$I_o = 100\text{ mA}$		0.2	0.4	V	
		$I_o = 100\text{ mA}$ $-40 < T_a < 125\text{ }^\circ\text{C}$			0.5	V	
$V_{il}$	Control Input Logic Low	$-40 < T_a < 125\text{ }^\circ\text{C}$			0.8	V	
$V_{ih}$	Control Input Logic High	$-40 < T_a < 125\text{ }^\circ\text{C}$	2			V	
$I_i$	Control Input Current	$V_i = 6\text{ V}$ , $V_c = 6\text{ V}$		10		$\mu\text{A}$	
$C_o$	Output Bypass Capacitance	$\text{ESR} = 0.1\text{ to }10\text{ }\Omega$ $I_o = 0\text{ to }100\text{ mA}$	2	10		$\mu\text{F}$	

## LE00AB/C

**ELECTRICAL CHARACTERISTICS FOR LE50AB** (refer to the test circuits,  $T_j = 25\text{ }^\circ\text{C}$ ,  
 $C_i = 0.1\text{ }\mu\text{F}$ ,  $C_o = 2.2\text{ }\mu\text{F}$  unless otherwise specified)

Symbol	Parameter	Test Conditions	Min.	Typ.	Max.	Unit	
$V_o$	Output Voltage	$I_o = 10\text{ mA}$ , $V_i = 7\text{ V}$	4.95	5	4.05	V	
		$I_o = 10\text{ mA}$ , $V_i = 7\text{ V}$ $-25 < T_a < 85\text{ }^\circ\text{C}$	4.9		5.1	V	
$V_i$	Operating Input Voltage	$I_o = 100\text{ mA}$			18	V	
$I_{out}$	Output Current Limit		150			mA	
$\Delta V_o$	Line Regulation	$V_i = 5.7\text{ to }18\text{ V}$ , $I_o = 0.5\text{ mA}$		4	20	mV	
$\Delta V_o$	Load Regulation	$V_i = 6\text{ V}$ $I_o = 0.5\text{ to }100\text{ mA}$		3	15	mV	
$I_d$	Quiescent Current	ON MODE					
		$V_i = 6\text{ to }18\text{ V}$ $I_o = 0\text{ mA}$		0.5	1	mA	
		$V_i = 6\text{ to }18\text{ V}$ $I_o = 100\text{ mA}$		1.5	3	mA	
		OFF MODE $V_i = 6\text{ V}$		50	100	$\mu\text{A}$	
SVR	Supply Voltage Rejection	$I_o = 5\text{ mA}$ $V_i = 7\text{ V} \pm 1\text{ V}$ $f = 120\text{ Hz}$ $f = 1\text{ KHz}$ $f = 10\text{ KHz}$		76		dB	
					71		dB
					60		dB
eN	Output Noise Voltage	$B = 10\text{ Hz to }100\text{ KHz}$		50		$\mu\text{V}$	
$V_d$	Dropout Voltage	$I_o = 100\text{ mA}$		0.2	0.4	V	
		$I_o = 100\text{ mA}$ $-40 < T_a < 125\text{ }^\circ\text{C}$			0.5	V	
$V_{il}$	Control Input Logic Low	$-40 < T_a < 125\text{ }^\circ\text{C}$			0.8	V	
$V_{ih}$	Control Input Logic High	$-40 < T_a < 125\text{ }^\circ\text{C}$	2			V	
$I_i$	Control Input Current	$V_i = 6\text{ V}$ , $V_c = 6\text{ V}$		10		$\mu\text{A}$	
$C_o$	Output Bypass Capacitance	$\text{ESR} = 0.1\text{ to }10\text{ }\Omega$ $I_o = 0\text{ to }100\text{ mA}$	2	10		$\mu\text{F}$	

**ELECTRICAL CHARACTERISTICS FOR LE50C** (refer to the test circuits,  $T_j = 25\text{ }^\circ\text{C}$ ,  
 $C_i = 0.1\text{ }\mu\text{F}$ ,  $C_o = 2.2\text{ }\mu\text{F}$  unless otherwise specified)

Symbol	Parameter	Test Conditions	Min.	Typ.	Max.	Unit	
$V_o$	Output Voltage	$I_o = 10\text{ mA}$ , $V_i = 7\text{ V}$	4.9	5	5.1	V	
		$I_o = 10\text{ mA}$ , $V_i = 7\text{ V}$ $-25 < T_a < 85\text{ }^\circ\text{C}$	4.8		5.2	V	
$V_i$	Operating Input Voltage	$I_o = 100\text{ mA}$			18	V	
$I_{out}$	Output Current Limit		150			mA	
$\Delta V_o$	Line Regulation	$V_i = 5.7\text{ to }18\text{ V}$ , $I_o = 0.5\text{ mA}$		4	30	mV	
$\Delta V_o$	Load Regulation	$V_i = 6\text{ V}$ $I_o = 0.5\text{ to }100\text{ mA}$		3	25	mV	
$I_d$	Quiescent Current	ON MODE					
		$V_i = 6\text{ to }18\text{ V}$ $I_o = 0\text{ mA}$		0.5	1	mA	
		$V_i = 6\text{ to }18\text{ V}$ $I_o = 100\text{ mA}$		1.5	3	mA	
		OFF MODE $V_i = 6\text{ V}$		50	100	$\mu\text{A}$	
SVR	Supply Voltage Rejection	$I_o = 5\text{ mA}$ $V_i = 7\text{ V} \pm 1\text{ V}$ $f = 120\text{ Hz}$ $f = 1\text{ KHz}$ $f = 10\text{ KHz}$		76		dB	
					71		dB
					60		dB
eN	Output Noise Voltage	$B = 10\text{ Hz to }100\text{ KHz}$		50		$\mu\text{V}$	
$V_d$	Dropout Voltage	$I_o = 100\text{ mA}$		0.2	0.4	V	
		$I_o = 100\text{ mA}$ $-40 < T_a < 125\text{ }^\circ\text{C}$			0.5	V	
$V_{il}$	Control Input Logic Low	$-40 < T_a < 125\text{ }^\circ\text{C}$			0.8	V	
$V_{ih}$	Control Input Logic High	$-40 < T_a < 125\text{ }^\circ\text{C}$	2			V	
$I_i$	Control Input Current	$V_i = 6\text{ V}$ , $V_c = 6\text{ V}$		10		$\mu\text{A}$	
$C_o$	Output Bypass Capacitance	$\text{ESR} = 0.1\text{ to }10\text{ }\Omega$ $I_o = 0\text{ to }100\text{ mA}$	2	10		$\mu\text{F}$	

**ELECTRICAL CHARACTERISTICS FOR LE52AB** (refer to the test circuits,  $T_j = 25\text{ }^\circ\text{C}$ ,  
 $C_i = 0.1\text{ }\mu\text{F}$ ,  $C_o = 2.2\text{ }\mu\text{F}$  unless otherwise specified)

Symbol	Parameter	Test Conditions	Min.	Typ.	Max.	Unit	
$V_o$	Output Voltage	$I_o = 10\text{ mA}$ , $V_i = 7.2\text{ V}$	5.148	5.2	5.252	V	
		$I_o = 10\text{ mA}$ , $V_i = 7.2\text{ V}$ $-25 < T_a < 85\text{ }^\circ\text{C}$	5.096		5.304	V	
$V_i$	Operating Input Voltage	$I_o = 100\text{ mA}$			18	V	
$I_{out}$	Output Current Limit		150			mA	
$\Delta V_o$	Line Regulation	$V_i = 5.9\text{ to }18\text{ V}$ , $I_o = 0.5\text{ mA}$		4	20	mV	
$\Delta V_o$	Load Regulation	$V_i = 6.2\text{ V}$ $I_o = 0.5\text{ to }100\text{ mA}$		3	15	mV	
$I_d$	Quiescent Current	ON MODE					
		$V_i = 6.2\text{ to }18\text{ V}$ $I_o = 0\text{ mA}$		0.5	1	mA	
		$V_i = 6.2\text{ to }18\text{ V}$ $I_o = 100\text{ mA}$		1.5	3	mA	
		OFF MODE $V_i = 6\text{ V}$		50	100	$\mu\text{A}$	
SVR	Supply Voltage Rejection	$I_o = 5\text{ mA}$ $V_i = 7.2\text{ V} \pm 1\text{ V}$ $f = 120\text{ Hz}$ $f = 1\text{ KHz}$ $f = 10\text{ KHz}$		76		dB	
					71		dB
					60		dB
eN	Output Noise Voltage	$B = 10\text{ Hz to }100\text{ KHz}$		50		$\mu\text{V}$	
$V_d$	Dropout Voltage	$I_o = 100\text{ mA}$		0.2	0.4	V	
		$I_o = 100\text{ mA}$ $-40 < T_a < 125\text{ }^\circ\text{C}$			0.5	V	
$V_{il}$	Control Input Logic Low	$-40 < T_a < 125\text{ }^\circ\text{C}$			0.8	V	
$V_{ih}$	Control Input Logic High	$-40 < T_a < 125\text{ }^\circ\text{C}$	2			V	
$I_i$	Control Input Current	$V_i = 6\text{ V}$ , $V_c = 6\text{ V}$		10		$\mu\text{A}$	
$C_o$	Output Bypass Capacitance	$\text{ESR} = 0.1\text{ to }10\text{ }\Omega$ $I_o = 0\text{ to }100\text{ mA}$	2	10		$\mu\text{F}$	

**ELECTRICAL CHARACTERISTICS FOR LE52C** (refer to the test circuits,  $T_j = 25\text{ }^\circ\text{C}$ ,  
 $C_i = 0.1\text{ }\mu\text{F}$ ,  $C_o = 2.2\text{ }\mu\text{F}$  unless otherwise specified)

Symbol	Parameter	Test Conditions	Min.	Typ.	Max.	Unit	
$V_o$	Output Voltage	$I_o = 10\text{ mA}$ , $V_i = 7.2\text{ V}$	5.096	5.2	5.304	V	
		$I_o = 10\text{ mA}$ , $V_i = 7.2\text{ V}$ $-25 < T_a < 85\text{ }^\circ\text{C}$	4.992		5.408	V	
$V_i$	Operating Input Voltage	$I_o = 100\text{ mA}$			18	V	
$I_{out}$	Output Current Limit		150			mA	
$\Delta V_o$	Line Regulation	$V_i = 5.9\text{ to }18\text{ V}$ , $I_o = 0.5\text{ mA}$		4	30	mV	
$\Delta V_o$	Load Regulation	$V_i = 6.2\text{ V}$ $I_o = 0.5\text{ to }100\text{ mA}$		3	25	mV	
$I_d$	Quiescent Current	ON MODE					
		$V_i = 6.2\text{ to }18\text{ V}$ $I_o = 0\text{ mA}$		0.5	1	mA	
		$V_i = 6.2\text{ to }18\text{ V}$ $I_o = 100\text{ mA}$		1.5	3	mA	
		OFF MODE $V_i = 6\text{ V}$		50	100	$\mu\text{A}$	
SVR	Supply Voltage Rejection	$I_o = 5\text{ mA}$ $V_i = 7.2\text{ V} \pm 1\text{ V}$ $f = 120\text{ Hz}$ $f = 1\text{ KHz}$ $f = 10\text{ KHz}$		76		dB	
					71		dB
					60		dB
eN	Output Noise Voltage	$B = 10\text{ Hz to }100\text{ KHz}$		50		$\mu\text{V}$	
$V_d$	Dropout Voltage	$I_o = 100\text{ mA}$		0.2	0.4	V	
		$I_o = 100\text{ mA}$ $-40 < T_a < 125\text{ }^\circ\text{C}$			0.5	V	
$V_{il}$	Control Input Logic Low	$-40 < T_a < 125\text{ }^\circ\text{C}$			0.8	V	
$V_{ih}$	Control Input Logic High	$-40 < T_a < 125\text{ }^\circ\text{C}$	2			V	
$I_i$	Control Input Current	$V_i = 6\text{ V}$ , $V_c = 6\text{ V}$		10		$\mu\text{A}$	
$C_o$	Output Bypass Capacitance	$\text{ESR} = 0.1\text{ to }10\text{ }\Omega$ $I_o = 0\text{ to }100\text{ mA}$	2	10		$\mu\text{F}$	

## LE00AB/C

**ELECTRICAL CHARACTERISTICS FOR LE55AB** (refer to the test circuits,  $T_j = 25\text{ }^\circ\text{C}$ ,  
 $C_i = 0.1\text{ }\mu\text{F}$ ,  $C_o = 2.2\text{ }\mu\text{F}$  unless otherwise specified)

Symbol	Parameter	Test Conditions	Min.	Typ.	Max.	Unit
$V_o$	Output Voltage	$I_o = 10\text{ mA}$ , $V_i = 7.5\text{ V}$	5.445	5.5	5.55	V
		$I_o = 10\text{ mA}$ , $V_i = 7.5\text{ V}$ $-25 < T_a < 85\text{ }^\circ\text{C}$	5.39		5.61	V
$V_i$	Operating Input Voltage	$I_o = 100\text{ mA}$			18	V
$I_{out}$	Output Current Limit		150			mA
$\Delta V_o$	Line Regulation	$V_i = 6.2\text{ to }18\text{ V}$ , $I_o = 0.5\text{ mA}$		4	20	mV
$\Delta V_o$	Load Regulation	$V_i = 6.5\text{ V}$ $I_o = 0.5\text{ to }100\text{ mA}$		3	15	mV
$I_d$	Quiescent Current	ON MODE				
		$V_i = 6.2\text{ to }18\text{ V}$ $I_o = 0\text{ mA}$		0.5	1	mA
		$V_i = 6.5\text{ to }18\text{ V}$ $I_o = 100\text{ mA}$		1.5	3	mA
		OFF MODE $V_i = 6\text{ V}$		50	100	$\mu\text{A}$
SVR	Supply Voltage Rejection	$I_o = 5\text{ mA}$ $V_i = 7.5\text{ V} \pm 1\text{ V}$				
		$f = 120\text{ Hz}$		76		dB
		$f = 1\text{ KHz}$		71		dB
		$f = 10\text{ KHz}$		60		dB
eN	Output Noise Voltage	$B = 10\text{ Hz to }100\text{ KHz}$		50		$\mu\text{V}$
$V_d$	Dropout Voltage	$I_o = 100\text{ mA}$		0.2	0.4	V
		$I_o = 100\text{ mA}$ $-40 < T_a < 125\text{ }^\circ\text{C}$			0.5	V
$V_{il}$	Control Input Logic Low	$-40 < T_a < 125\text{ }^\circ\text{C}$			0.8	V
$V_{ih}$	Control Input Logic High	$-40 < T_a < 125\text{ }^\circ\text{C}$	2			V
$I_i$	Control Input Current	$V_i = 6\text{ V}$ , $V_c = 6\text{ V}$		10		$\mu\text{A}$
$C_o$	Output Bypass Capacitance	$\text{ESR} = 0.1\text{ to }10\text{ }\Omega$ $I_o = 0\text{ to }100\text{ mA}$	2	10		$\mu\text{F}$

**ELECTRICAL CHARACTERISTICS FOR LE55C** (refer to the test circuits,  $T_j = 25\text{ }^\circ\text{C}$ ,  
 $C_i = 0.1\text{ }\mu\text{F}$ ,  $C_o = 2.2\text{ }\mu\text{F}$  unless otherwise specified)

Symbol	Parameter	Test Conditions	Min.	Typ.	Max.	Unit
$V_o$	Output Voltage	$I_o = 10\text{ mA}$ , $V_i = 7.5\text{ V}$	5.39	5.5	5.61	V
		$I_o = 10\text{ mA}$ , $V_i = 7.5\text{ V}$ $-25 < T_a < 85\text{ }^\circ\text{C}$	5.28		5.72	V
$V_i$	Operating Input Voltage	$I_o = 100\text{ mA}$			18	V
$I_{out}$	Output Current Limit		150			mA
$\Delta V_o$	Line Regulation	$V_i = 6.2\text{ to }18\text{ V}$ , $I_o = 0.5\text{ mA}$		4	30	mV
$\Delta V_o$	Load Regulation	$V_i = 6.5\text{ V}$ $I_o = 0.5\text{ to }100\text{ mA}$		3	25	mV
$I_d$	Quiescent Current	ON MODE				
		$V_i = 6.5\text{ to }18\text{ V}$ $I_o = 0\text{ mA}$		0.5	1	mA
		$V_i = 6.5\text{ to }18\text{ V}$ $I_o = 100\text{ mA}$		1.5	3	mA
		OFF MODE $V_i = 6\text{ V}$		50	100	$\mu\text{A}$
SVR	Supply Voltage Rejection	$I_o = 5\text{ mA}$ $V_i = 7.5\text{ V} \pm 1\text{ V}$				
		$f = 120\text{ Hz}$		76		dB
		$f = 1\text{ KHz}$		71		dB
		$f = 10\text{ KHz}$		60		dB
eN	Output Noise Voltage	$B = 10\text{ Hz to }100\text{ KHz}$		50		$\mu\text{V}$
$V_d$	Dropout Voltage	$I_o = 100\text{ mA}$		0.2	0.4	V
		$I_o = 100\text{ mA}$ $-40 < T_a < 125\text{ }^\circ\text{C}$			0.5	V
$V_{il}$	Control Input Logic Low	$-40 < T_a < 125\text{ }^\circ\text{C}$			0.8	V
$V_{ih}$	Control Input Logic High	$-40 < T_a < 125\text{ }^\circ\text{C}$	2			V
$I_i$	Control Input Current	$V_i = 6\text{ V}$ , $V_c = 6\text{ V}$		10		$\mu\text{A}$
$C_o$	Output Bypass Capacitance	$\text{ESR} = 0.1\text{ to }10\text{ }\Omega$ $I_o = 0\text{ to }100\text{ mA}$	2	10		$\mu\text{F}$



**ELECTRICAL CHARACTERISTICS FOR LE60AB** (refer to the test circuits,  $T_j = 25\text{ }^\circ\text{C}$ ,  
 $C_i = 0.1\text{ }\mu\text{F}$ ,  $C_o = 2.2\text{ }\mu\text{F}$  unless otherwise specified)

Symbol	Parameter	Test Conditions	Min.	Typ.	Max.	Unit	
$V_o$	Output Voltage	$I_o = 10\text{ mA}$ , $V_i = 8\text{ V}$	5.94	6	6.06	V	
		$I_o = 10\text{ mA}$ , $V_i = 8\text{ V}$ $-25 < T_a < 85\text{ }^\circ\text{C}$	5.88		6.12	V	
$V_i$	Operating Input Voltage	$I_o = 100\text{ mA}$			18	V	
$I_{out}$	Output Current Limit		150			mA	
$\Delta V_o$	Line Regulation	$V_i = 6.7\text{ to }18\text{ V}$ , $I_o = 0.5\text{ mA}$		5	25	mV	
$\Delta V_o$	Load Regulation	$V_i = 7\text{ V}$ $I_o = 0.5\text{ to }100\text{ mA}$		3	15	mV	
$I_d$	Quiescent Current	ON MODE					
		$V_i = 7\text{ to }18\text{ V}$ $I_o = 0\text{ mA}$		0.7	1.6	mA	
		$V_i = 7\text{ to }18\text{ V}$ $I_o = 100\text{ mA}$		1.7	3.6	mA	
	OFF MODE $V_i = 9\text{ V}$		70	140	$\mu\text{A}$		
SVR	Supply Voltage Rejection	$I_o = 5\text{ mA}$ $V_i = 8\text{ V} \pm 1\text{ V}$ $f = 120\text{ Hz}$ $f = 1\text{ KHz}$ $f = 10\text{ KHz}$		75		dB	
					69		dB
					57		dB
eN	Output Noise Voltage	$B = 10\text{ Hz to }100\text{ KHz}$		50		$\mu\text{V}$	
$V_d$	Dropout Voltage	$I_o = 100\text{ mA}$		0.2	0.4	V	
		$I_o = 100\text{ mA}$ $-40 < T_a < 125\text{ }^\circ\text{C}$			0.5	V	
$V_{il}$	Control Input Logic Low	$-40 < T_a < 125\text{ }^\circ\text{C}$			0.8	V	
$V_{ih}$	Control Input Logic High	$-40 < T_a < 125\text{ }^\circ\text{C}$	2			V	
$I_i$	Control Input Current	$V_i = 9\text{ V}$ , $V_c = 6\text{ V}$		10		$\mu\text{A}$	
$C_o$	Output Bypass Capacitance	$\text{ESR} = 0.1\text{ to }10\text{ }\Omega$ $I_o = 0\text{ to }100\text{ mA}$	2	10		$\mu\text{F}$	

**ELECTRICAL CHARACTERISTICS FOR LE60C** (refer to the test circuits,  $T_j = 25\text{ }^\circ\text{C}$ ,  
 $C_i = 0.1\text{ }\mu\text{F}$ ,  $C_o = 2.2\text{ }\mu\text{F}$  unless otherwise specified)

Symbol	Parameter	Test Conditions	Min.	Typ.	Max.	Unit	
$V_o$	Output Voltage	$I_o = 10\text{ mA}$ , $V_i = 8\text{ V}$	5.88	6	6.12	V	
		$I_o = 10\text{ mA}$ , $V_i = 8\text{ V}$ $-25 < T_a < 85\text{ }^\circ\text{C}$	5.76		6.24	V	
$V_i$	Operating Input Voltage	$I_o = 100\text{ mA}$			18	V	
$I_{out}$	Output Current Limit		150			mA	
$\Delta V_o$	Line Regulation	$V_i = 6.7\text{ to }18\text{ V}$ , $I_o = 0.5\text{ mA}$		5	35	mV	
$\Delta V_o$	Load Regulation	$V_i = 7\text{ V}$ $I_o = 0.5\text{ to }100\text{ mA}$		3	25	mV	
$I_d$	Quiescent Current	ON MODE					
		$V_i = 7\text{ to }18\text{ V}$ $I_o = 0\text{ mA}$		0.7	1.6	mA	
		$V_i = 7\text{ to }18\text{ V}$ $I_o = 100\text{ mA}$		1.7	3.6	mA	
	OFF MODE $V_i = 9\text{ V}$		70	140	$\mu\text{A}$		
SVR	Supply Voltage Rejection	$I_o = 5\text{ mA}$ $V_i = 8\text{ V} \pm 1\text{ V}$ $f = 120\text{ Hz}$ $f = 1\text{ KHz}$ $f = 10\text{ KHz}$		75		dB	
					69		dB
					57		dB
eN	Output Noise Voltage	$B = 10\text{ Hz to }100\text{ KHz}$		50		$\mu\text{V}$	
$V_d$	Dropout Voltage	$I_o = 100\text{ mA}$		0.2	0.4	V	
		$I_o = 100\text{ mA}$ $-40 < T_a < 125\text{ }^\circ\text{C}$			0.5	V	
$V_{il}$	Control Input Logic Low	$-40 < T_a < 125\text{ }^\circ\text{C}$			0.8	V	
$V_{ih}$	Control Input Logic High	$-40 < T_a < 125\text{ }^\circ\text{C}$	2			V	
$I_i$	Control Input Current	$V_i = 9\text{ V}$ , $V_c = 6\text{ V}$		10		$\mu\text{A}$	
$C_o$	Output Bypass Capacitance	$\text{ESR} = 0.1\text{ to }10\text{ }\Omega$ $I_o = 0\text{ to }100\text{ mA}$	2	10		$\mu\text{F}$	

## LE00AB/C

**ELECTRICAL CHARACTERISTICS FOR LE80AB** (refer to the test circuits,  $T_j = 25\text{ }^\circ\text{C}$ ,  
 $C_i = 0.1\text{ }\mu\text{F}$ ,  $C_o = 2.2\text{ }\mu\text{F}$  unless otherwise specified)

Symbol	Parameter	Test Conditions	Min.	Typ.	Max.	Unit
$V_o$	Output Voltage	$I_o = 10\text{ mA}$ , $V_i = 10\text{ V}$	7.92	8	8.08	V
		$I_o = 10\text{ mA}$ , $V_i = 10\text{ V}$ $-25 < T_a < 85\text{ }^\circ\text{C}$	7.84		8.16	V
$V_i$	Operating Input Voltage	$I_o = 100\text{ mA}$			18	V
$I_{out}$	Output Current Limit		150			mA
$\Delta V_o$	Line Regulation	$V_i = 8.7\text{ to }18\text{ V}$ , $I_o = 0.5\text{ mA}$		5	25	mV
$\Delta V_o$	Load Regulation	$V_i = 9\text{ V}$ $I_o = 0.5\text{ to }100\text{ mA}$		3	15	mV
$I_d$	Quiescent Current	ON MODE				
		$V_i = 9\text{ to }18\text{ V}$ $I_o = 0\text{ mA}$		0.7	1.6	mA
		$V_i = 9\text{ to }18\text{ V}$ $I_o = 100\text{ mA}$		1.7	3.6	mA
	OFF MODE $V_i = 9\text{ V}$		70	140	$\mu\text{A}$	
SVR	Supply Voltage Rejection	$I_o = 5\text{ mA}$ $V_i = 10\text{ V} \pm 1\text{ V}$				
		$f = 120\text{ Hz}$		72		dB
		$f = 1\text{ KHz}$		66		dB
		$f = 10\text{ KHz}$		57		dB
eN	Output Noise Voltage	$B = 10\text{ Hz to }100\text{ KHz}$		50		$\mu\text{V}$
$V_d$	Dropout Voltage	$I_o = 100\text{ mA}$		0.2	0.4	V
		$I_o = 100\text{ mA}$ $-40 < T_a < 125\text{ }^\circ\text{C}$			0.5	V
$V_{il}$	Control Input Logic Low	$-40 < T_a < 125\text{ }^\circ\text{C}$			0.8	V
$V_{ih}$	Control Input Logic High	$-40 < T_a < 125\text{ }^\circ\text{C}$	2			V
$I_i$	Control Input Current	$V_i = 9\text{ V}$ , $V_c = 6\text{ V}$		10		$\mu\text{A}$
$C_o$	Output Bypass Capacitance	$\text{ESR} = 0.1\text{ to }10\text{ }\Omega$ $I_o = 0\text{ to }100\text{ mA}$	2	10		$\mu\text{F}$

**ELECTRICAL CHARACTERISTICS FOR LE80C** (refer to the test circuits,  $T_j = 25\text{ }^\circ\text{C}$ ,  
 $C_i = 0.1\text{ }\mu\text{F}$ ,  $C_o = 2.2\text{ }\mu\text{F}$  unless otherwise specified)

Symbol	Parameter	Test Conditions	Min.	Typ.	Max.	Unit
$V_o$	Output Voltage	$I_o = 10\text{ mA}$ , $V_i = 10\text{ V}$	7.84	8	8.16	V
		$I_o = 10\text{ mA}$ , $V_i = 10\text{ V}$ $-25 < T_a < 85\text{ }^\circ\text{C}$	7.68		8.32	V
$V_i$	Operating Input Voltage	$I_o = 100\text{ mA}$			18	V
$I_{out}$	Output Current Limit		150			mA
$\Delta V_o$	Line Regulation	$V_i = 9\text{ to }18\text{ V}$ , $I_o = 0.5\text{ mA}$		5	35	mV
$\Delta V_o$	Load Regulation	$V_i = 9\text{ V}$ $I_o = 0.5\text{ to }100\text{ mA}$		3	25	mV
$I_d$	Quiescent Current	ON MODE				
		$V_i = 9\text{ to }18\text{ V}$ $I_o = 0\text{ mA}$		0.7	1.6	mA
		$V_i = 9\text{ to }18\text{ V}$ $I_o = 100\text{ mA}$		1.7	3.6	mA
	OFF MODE $V_i = 9\text{ V}$		70	140	$\mu\text{A}$	
SVR	Supply Voltage Rejection	$I_o = 5\text{ mA}$ $V_i = 10\text{ V} \pm 1\text{ V}$				
		$f = 120\text{ Hz}$		72		dB
		$f = 1\text{ KHz}$		66		dB
		$f = 10\text{ KHz}$		57		dB
eN	Output Noise Voltage	$B = 10\text{ Hz to }100\text{ KHz}$		50		$\mu\text{V}$
$V_d$	Dropout Voltage	$I_o = 100\text{ mA}$		0.2	0.4	V
		$I_o = 100\text{ mA}$ $-40 < T_a < 125\text{ }^\circ\text{C}$			0.5	V
$V_{il}$	Control Input Logic Low	$-40 < T_a < 125\text{ }^\circ\text{C}$			0.8	V
$V_{ih}$	Control Input Logic High	$-40 < T_a < 125\text{ }^\circ\text{C}$	2			V
$I_i$	Control Input Current	$V_i = 9\text{ V}$ , $V_c = 6\text{ V}$		10		$\mu\text{A}$
$C_o$	Output Bypass Capacitance	$\text{ESR} = 0.1\text{ to }10\text{ }\Omega$ $I_o = 0\text{ to }100\text{ mA}$	2	10		$\mu\text{F}$

**ELECTRICAL CHARACTERISTICS FOR LE120AB** (refer to the test circuits,  $T_j = 25\text{ }^\circ\text{C}$ ,  
 $C_i = 0.1\text{ }\mu\text{F}$ ,  $C_o = 2.2\text{ }\mu\text{F}$  unless otherwise specified)

Symbol	Parameter	Test Conditions	Min.	Typ.	Max.	Unit	
$V_o$	Output Voltage	$I_o = 10\text{ mA}$ , $V_i = 14\text{ V}$	11.88	12	12.12	V	
		$I_o = 10\text{ mA}$ , $V_i = 14\text{ V}$ $-25 < T_a < 85\text{ }^\circ\text{C}$	11.76		12.24	V	
$V_i$	Operating Input Voltage	$I_o = 100\text{ mA}$			18	V	
$I_{out}$	Output Current Limit		150			mA	
$\Delta V_o$	Line Regulation	$V_i = 12.7\text{ to }18\text{ V}$ , $I_o = 0.5\text{ mA}$		5	25	mV	
$\Delta V_o$	Load Regulation	$V_i = 13\text{ V}$ $I_o = 0.5\text{ to }100\text{ mA}$		3	15	mV	
$I_d$	Quiescent Current	ON MODE					
		$V_i = 13\text{ to }18\text{ V}$ $I_o = 0\text{ mA}$		0.7	1.6	mA	
		$V_i = 13\text{ to }18\text{ V}$ $I_o = 100\text{ mA}$		1.7	3.6	mA	
	OFF MODE $V_i = 13\text{ V}$		90	180	$\mu\text{A}$		
SVR	Supply Voltage Rejection	$I_o = 5\text{ mA}$ $V_i = 14\text{ V} \pm 1\text{ V}$ $f = 120\text{ Hz}$ $f = 1\text{ KHz}$ $f = 10\text{ KHz}$		69		dB	
					63		dB
					55		dB
eN	Output Noise Voltage	$B = 10\text{ Hz to }100\text{ KHz}$		50		$\mu\text{V}$	
$V_d$	Dropout Voltage	$I_o = 100\text{ mA}$		0.2	0.4	V	
		$I_o = 100\text{ mA}$ $-40 < T_a < 125\text{ }^\circ\text{C}$			0.5	V	
$V_{il}$	Control Input Logic Low	$-40 < T_a < 125\text{ }^\circ\text{C}$			0.8	V	
$V_{ih}$	Control Input Logic High	$-40 < T_a < 125\text{ }^\circ\text{C}$	2			V	
$I_i$	Control Input Current	$V_i = 13\text{ V}$ , $V_c = 6\text{ V}$		10		$\mu\text{A}$	
$C_o$	Output Bypass Capacitance	$\text{ESR} = 0.1\text{ to }10\text{ }\Omega$ $I_o = 0\text{ to }100\text{ mA}$	2	10		$\mu\text{F}$	

**ELECTRICAL CHARACTERISTICS FOR LE120C** (refer to the test circuits,  $T_j = 25\text{ }^\circ\text{C}$ ,  
 $C_i = 0.1\text{ }\mu\text{F}$ ,  $C_o = 2.2\text{ }\mu\text{F}$  unless otherwise specified)

Symbol	Parameter	Test Conditions	Min.	Typ.	Max.	Unit	
$V_o$	Output Voltage	$I_o = 10\text{ mA}$ , $V_i = 14\text{ V}$	11.76	12	12.24	V	
		$I_o = 10\text{ mA}$ , $V_i = 14\text{ V}$ $-25 < T_a < 85\text{ }^\circ\text{C}$	11.52		12.48	V	
$V_i$	Operating Input Voltage	$I_o = 100\text{ mA}$			18	V	
$I_{out}$	Output Current Limit		150			mA	
$\Delta V_o$	Line Regulation	$V_i = 12.7\text{ to }18\text{ V}$ , $I_o = 0.5\text{ mA}$		5	35	mV	
$\Delta V_o$	Load Regulation	$V_i = 13\text{ V}$ $I_o = 0.5\text{ to }100\text{ mA}$		3	25	mV	
$I_d$	Quiescent Current	ON MODE					
		$V_i = 13\text{ to }18\text{ V}$ $I_o = 0\text{ mA}$		0.7	1.6	mA	
		$V_i = 13\text{ to }18\text{ V}$ $I_o = 100\text{ mA}$		1.7	3.6	mA	
	OFF MODE $V_i = 13\text{ V}$		90	180	$\mu\text{A}$		
SVR	Supply Voltage Rejection	$I_o = 5\text{ mA}$ $V_i = 14\text{ V} \pm 1\text{ V}$ $f = 120\text{ Hz}$ $f = 1\text{ KHz}$ $f = 10\text{ KHz}$		69		dB	
					63		dB
					55		dB
eN	Output Noise Voltage	$B = 10\text{ Hz to }100\text{ KHz}$		50		$\mu\text{V}$	
$V_d$	Dropout Voltage	$I_o = 100\text{ mA}$		0.2	0.4	V	
		$I_o = 100\text{ mA}$ $-40 < T_a < 125\text{ }^\circ\text{C}$			0.5	V	
$V_{il}$	Control Input Logic Low	$-40 < T_a < 125\text{ }^\circ\text{C}$			0.8	V	
$V_{ih}$	Control Input Logic High	$-40 < T_a < 125\text{ }^\circ\text{C}$	2			V	
$I_i$	Control Input Current	$V_i = 13\text{ V}$ , $V_c = 6\text{ V}$		10		$\mu\text{A}$	
$C_o$	Output Bypass Capacitance	$\text{ESR} = 0.1\text{ to }10\text{ }\Omega$ $I_o = 0\text{ to }100\text{ mA}$	2	10		$\mu\text{F}$	

**TYPICAL PERFORMANCE CHARACTERISTICS** (unless otherwise specified  $T_j=25^\circ\text{C}$ )

Dropout Voltage vs Output Current

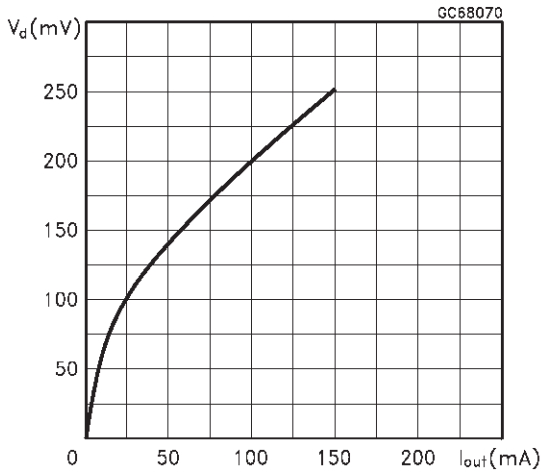

Dropout Voltage vs Temperature

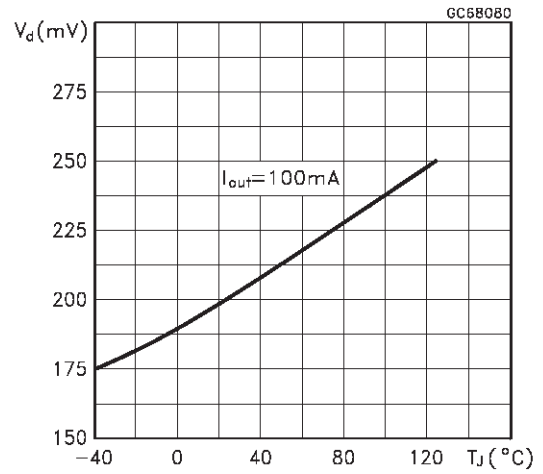

Supply Current vs Temperature

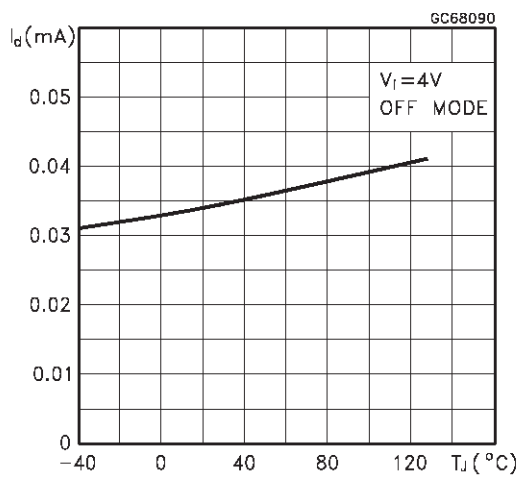

Supply Current vs Input Voltage

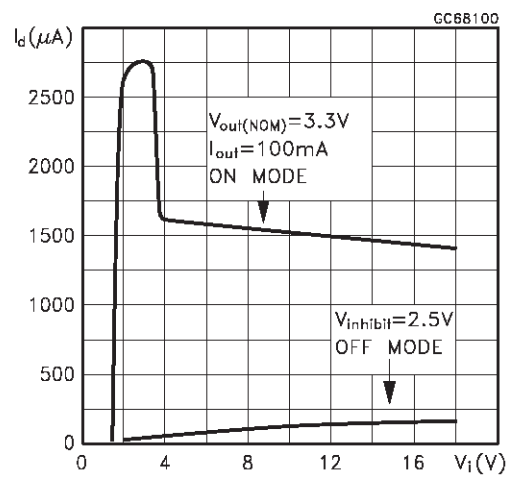

Short Circuit Current vs Dropout Voltage

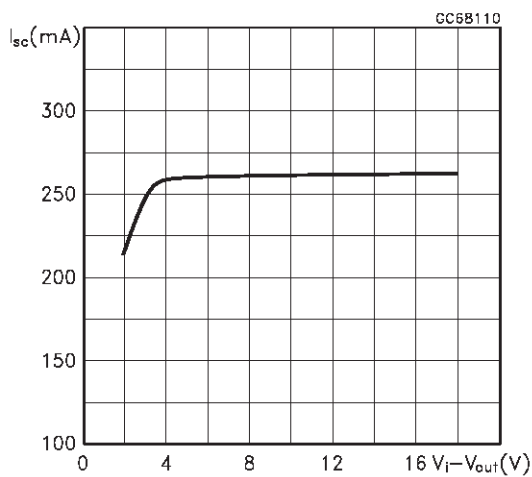

S.V.R. vs Frequency

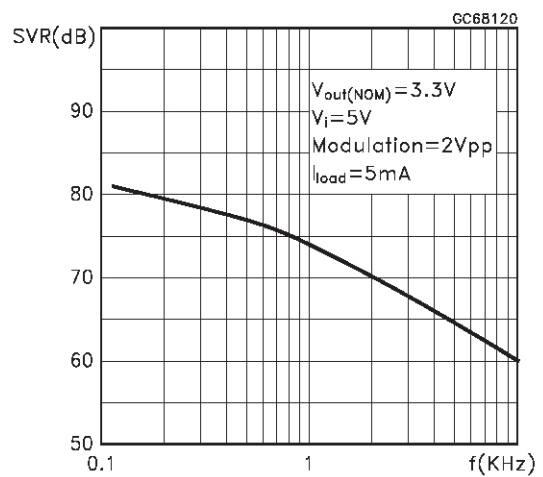

Logic Controlled Precision 3.3/5.0V Selectable Output

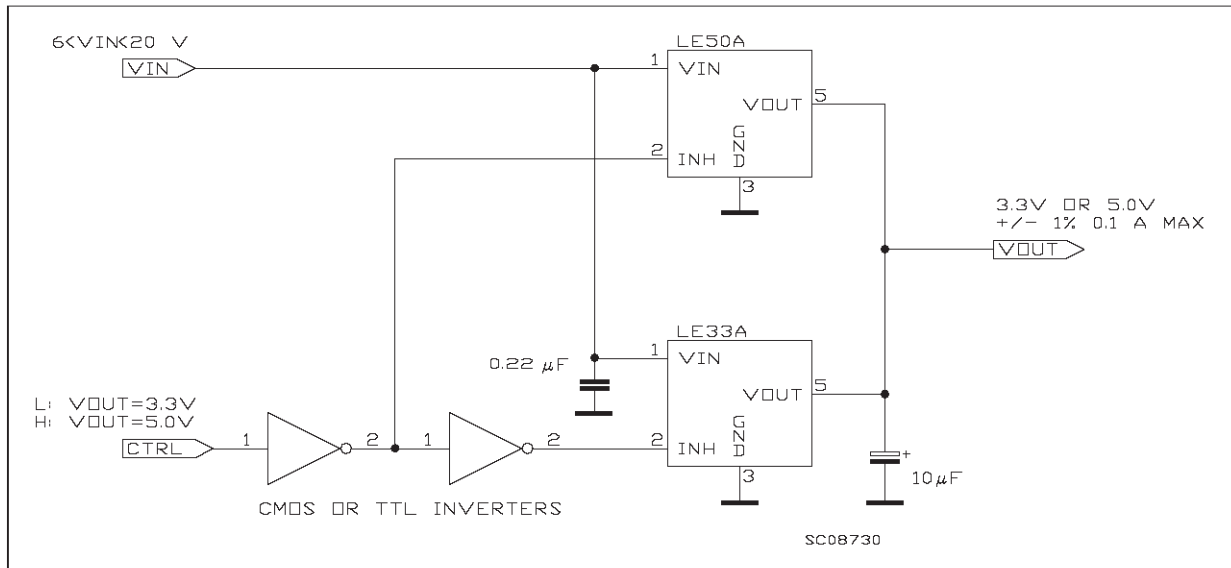

Sequential Multi-Output Supply

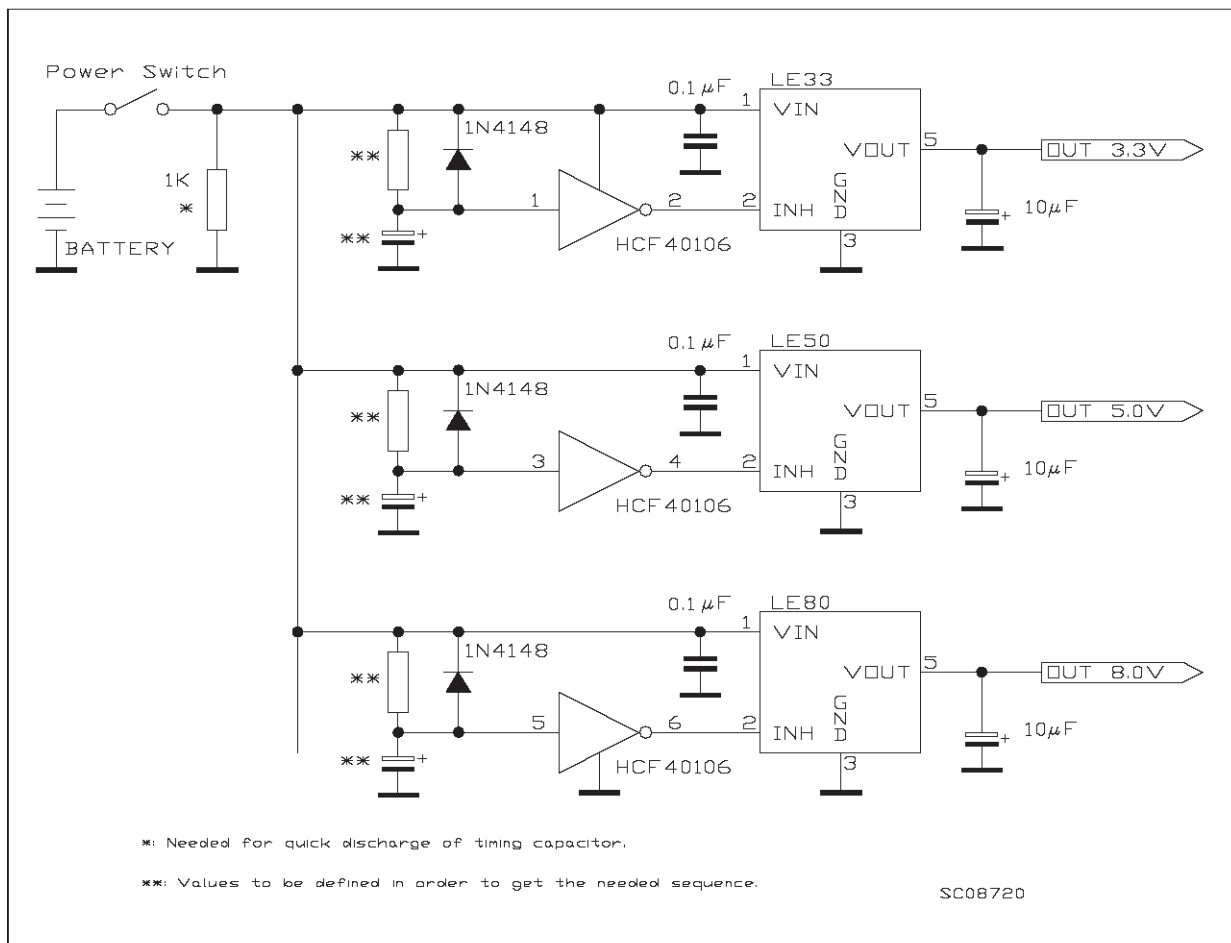

# LE00AB/C

## Multiple Supply With ON/OFF Toggle Switch

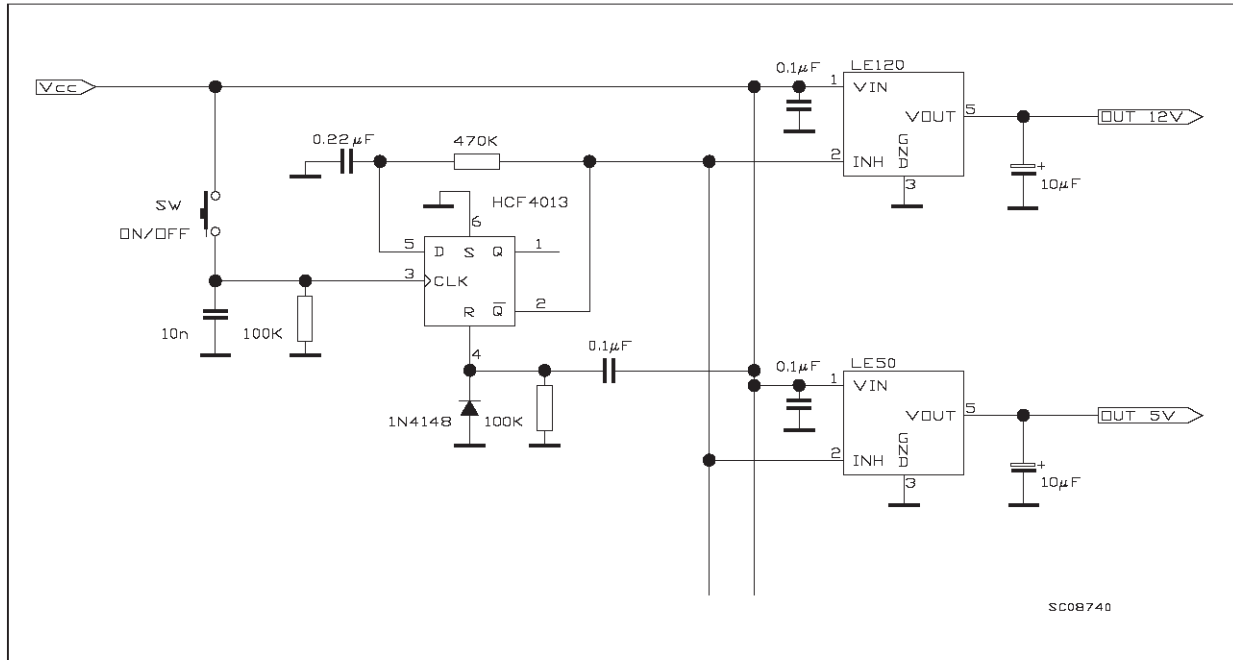

## Basic Inhibit Functions

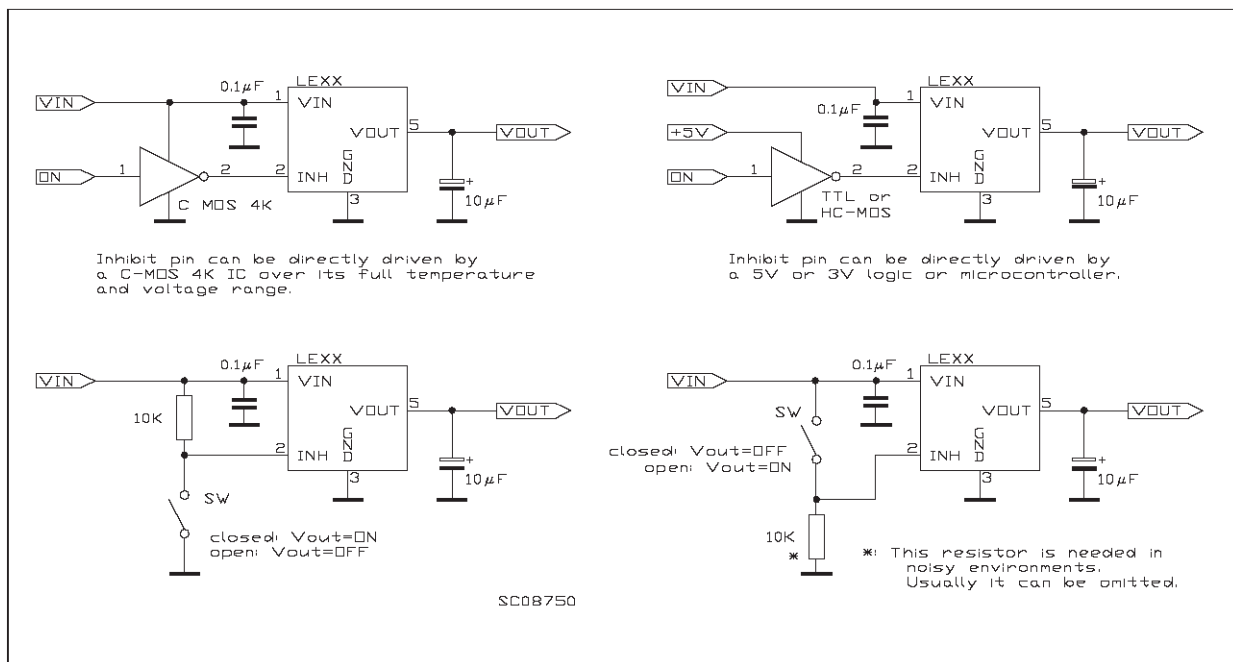

## SO-8 MECHANICAL DATA

DIM.	mm			inch		
	MIN.	TYP.	MAX.	MIN.	TYP.	MAX.
A			1.75			0.068
a1	0.1		0.25	0.003		0.009
a2			1.65			0.064
a3	0.65		0.85	0.025		0.033
b	0.35		0.48	0.013		0.018
b1	0.19		0.25	0.007		0.010
C	0.25		0.5	0.010		0.019
c1	45 (typ.)					
D	4.8		5.0	0.188		0.196
E	5.8		6.2	0.228		0.244
e		1.27			0.050	
e3		3.81			0.150	
F	3.8		4.0	0.14		0.157
L	0.4		1.27	0.015		0.050
M			0.6			0.023
S	8 (max.)					

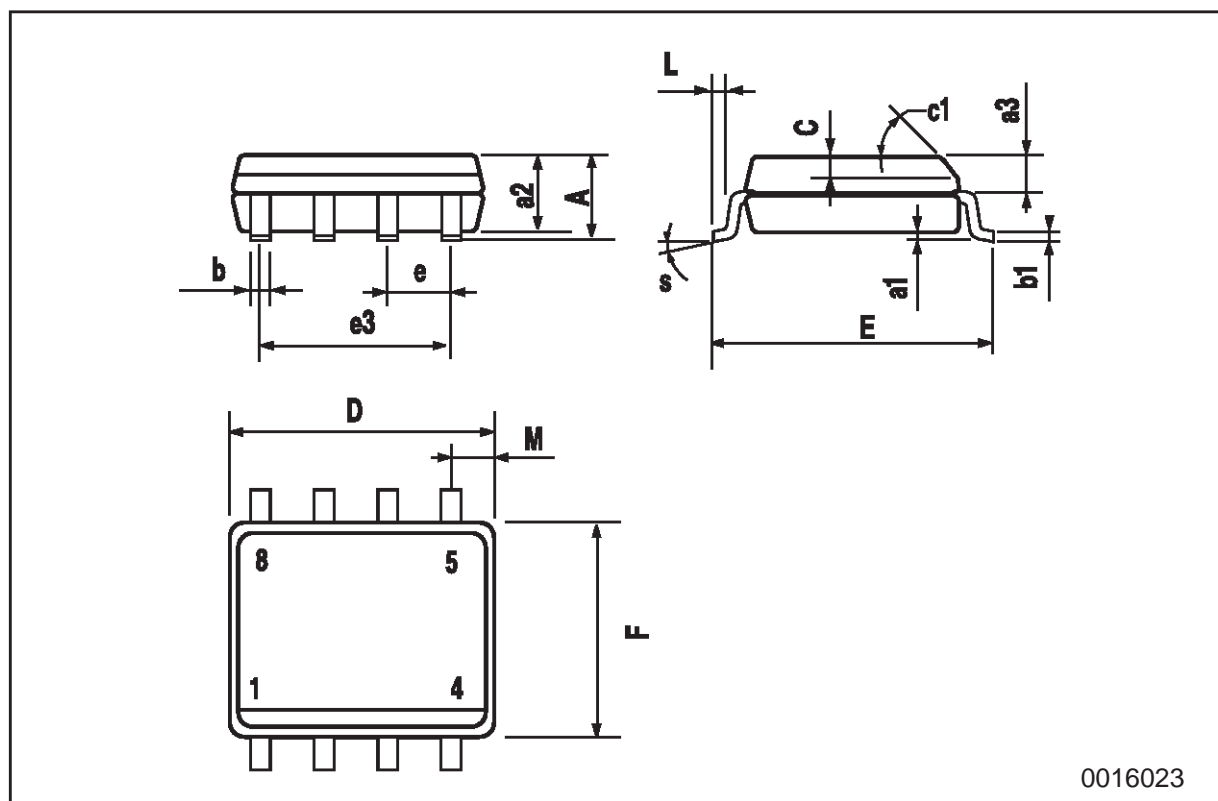

**TO-92 MECHANICAL DATA**

DIM.	mm			inch		
	MIN.	TYP.	MAX.	MIN.	TYP.	MAX.
A	4.58		5.33	0.180		0.210
B	4.45		5.2	0.175		0.204
C	3.2		4.2	0.126		0.165
D	12.7			0.500		
E		1.27			0.050	
F	0.4		0.51	0.016		0.020
G	0.35			0.14		

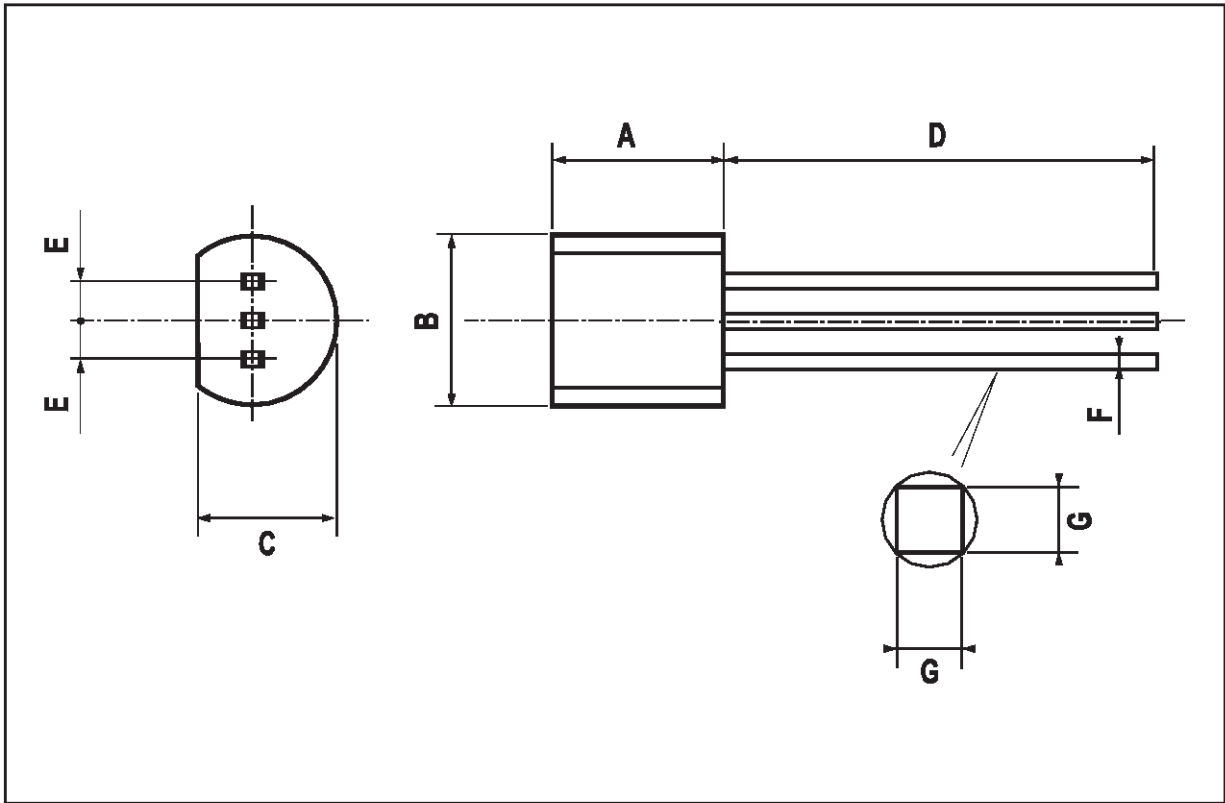



Information furnished is believed to be accurate and reliable. However, STMicroelectronics assumes no responsibility for the consequences of use of such information nor for any infringement of patents or other rights of third parties which may result from its use. No license is granted by implication or otherwise under any patent or patent rights of STMicroelectronics. Specification mentioned in this publication are subject to change without notice. This publication supersedes and replaces all information previously supplied. STMicroelectronics products are not authorized for use as critical components in life support devices or systems without express written approval of STMicroelectronics.

The ST logo is a trademark of STMicroelectronics

© 1998 STMicroelectronics – Printed in Italy – All Rights Reserved

STMicroelectronics GROUP OF COMPANIES

Australia - Brazil - Canada - China - France - Germany - Italy - Japan - Korea - Malaysia - Malta - Mexico - Morocco - The Netherlands - Singapore - Spain - Sweden - Switzerland - Taiwan - Thailand - United Kingdom - U.S.A.

