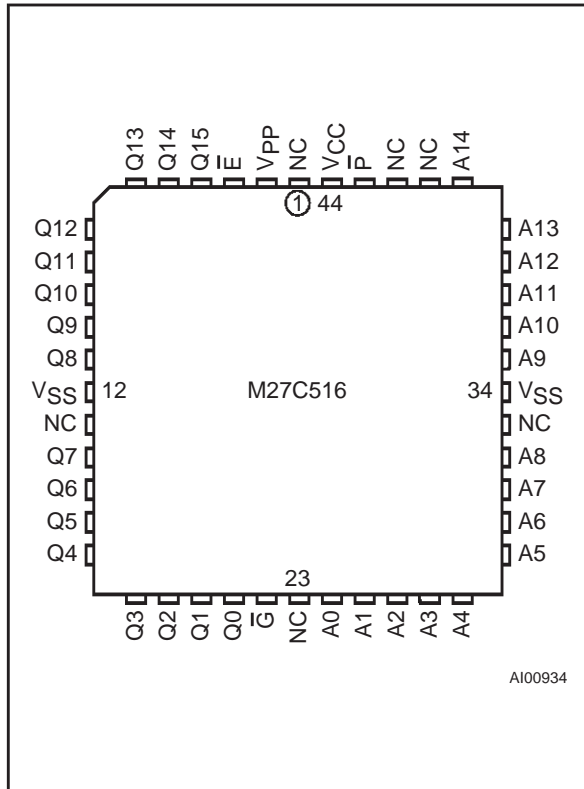

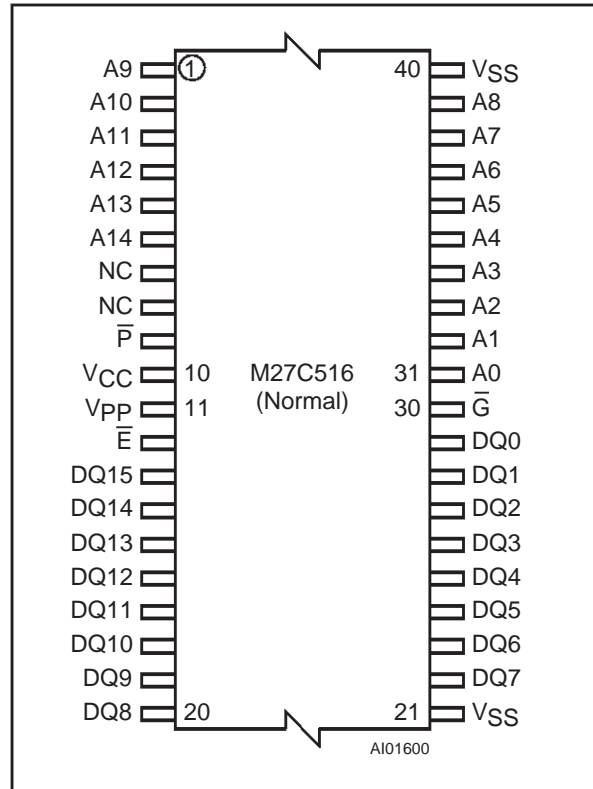

Figure 2A. LCC Pin Connections



Warning: NC = Not Connected.

Figure 2B. TSOP Pin Connections



Warning: NC = Not Connected.

Table 2. Absolute Maximum Ratings <sup>(1)</sup>

Symbol	Parameter	Value	Unit
T <sub>A</sub>	Ambient Operating Temperature <sup>(3)</sup>	-40 to 125	°C
T <sub>BIAS</sub>	Temperature Under Bias	-50 to 125	°C
T <sub>STG</sub>	Storage Temperature	-65 to 150	°C
V <sub>IO</sub> <sup>(2)</sup>	Input or Output Voltages (except A9)	-2 to 7	V
V <sub>CC</sub>	Supply Voltage	-2 to 7	V
V <sub>A9</sub> <sup>(2)</sup>	A9 Voltage	-2 to 13.5	V
V <sub>PP</sub>	Program Supply Voltage	-2 to 14	V

**Notes:** 1. Except for the rating "Operating Temperature Range", stresses above those listed in the Table "Absolute Maximum Ratings" may cause permanent damage to the device. These are stress ratings only and operation of the device at these or any other conditions above those indicated in the Operating sections of this specification is not implied. Exposure to Absolute Maximum Rating conditions for extended periods may affect device reliability. Refer also to the STMicroelectronics SURE Program and other relevant quality documents.

2. Minimum DC voltage on Input or Output is -0.5V with possible undershoot to -2.0V for a period less than 20ns. Maximum DC voltage on Output is V<sub>CC</sub> +0.5V with possible overshoot to V<sub>CC</sub> +2V for a period less than 20ns.

3. Depends on range.

Table 3. Operating Modes

Mode	$\bar{E}$	$\bar{G}$	$\bar{P}$	A9	V <sub>PP</sub>	Q0 - Q15
Read	V <sub>IL</sub>	V <sub>IL</sub>	V <sub>IH</sub>	X	V <sub>CC</sub>	Data Out
Output Disable	V <sub>IL</sub>	V <sub>IH</sub>	X	X	V <sub>CC</sub>	Hi-Z
Program	V <sub>IL</sub>	X	V <sub>IL</sub> Pulse	X	V <sub>PP</sub>	Data In
Verify	V <sub>IL</sub>	V <sub>IL</sub>	V <sub>IH</sub>	X	V <sub>PP</sub>	Data Out
Program Inhibit	V <sub>IH</sub>	X	X	X	V <sub>PP</sub>	Hi-Z
Standby	V <sub>IH</sub>	X	X	X	V <sub>CC</sub>	Hi-Z
Electronic Signature	V <sub>IL</sub>	V <sub>IL</sub>	V <sub>IH</sub>	V <sub>ID</sub>	V <sub>CC</sub>	Codes

Notes: X = V<sub>IH</sub> or V<sub>IL</sub>, V<sub>ID</sub> = 12V ± 0.5V

Table 4. Electronic Signature

Identifier	A0	Q7	Q6	Q5	Q4	Q3	Q2	Q1	Q0	Hex Data
Manufacturer's Code	V <sub>IL</sub>	0	0	1	0	0	0	0	0	20h
Device Code	V <sub>IH</sub>	0	0	0	0	1	1	1	1	0Fh

Note: Outputs Q8-Q15 are set to '0'.

## DEVICE OPERATION

The operating modes of the M27C516 are listed in the Operating Modes table. A single power supply is required in the read mode. All inputs are TTL levels except for  $\bar{G}$  and 12V on A9 for Electronic Signature.

### Read Mode

The M27C516 has two control functions, both of which must be logically active in order to obtain data at the outputs. Chip Enable ( $\bar{E}$ ) is the power control and should be used for device selection. Output Enable ( $\bar{G}$ ) is the output control and should be used to gate data to the output pins, independent of device selection. Assuming that the addresses are stable, the address access time ( $t_{AVQV}$ ) is equal to the delay from  $\bar{E}$  to output ( $t_{ELQV}$ ). Data is available at the output after a delay of  $t_{GLQV}$  from the falling edge of  $\bar{G}$ , assuming that  $\bar{E}$  has been low and the addresses have been stable for at least  $t_{AVQV} - t_{GLQV}$ .

### Standby Mode

The M27C516 has a standby mode which reduces the supply current from 30mA to 100µA. The

M27C516 is placed in the standby mode by applying a CMOS high signal to the  $\bar{E}$  input. When in the standby mode, the outputs are in a high impedance state, independent of the  $\bar{G}$  input.

### Two Line Output Control

Because OTP EPROMs are usually used in larger memory arrays, the product features a 2 line control function which accommodates the use of multiple memory connection. The two line control function allows:

- the lowest possible memory power dissipation,
- complete assurance that output bus contention will not occur.

For the most efficient use of these two control lines,  $\bar{E}$  should be decoded and used as the primary device selecting function, while  $\bar{G}$  should be made a common connection to all devices in the array and connected to the  $\overline{READ}$  line from the system control bus. This ensures that all deselected memory devices are in their low power standby mode and that the output pins are only active when data is required from a particular memory device.

**Table 5. AC Measurement Conditions**

	High Speed	Standard
Input Rise and Fall Times	≤ 10ns	≤ 20ns (10% to 90%)
Input Pulse Voltages	0 to 3V	0.4V to 2.4V
Input and Output Timing Ref. Voltages	1.5V	0.8V and 2V

**Figure 3. AC Testing Input Output Waveform**

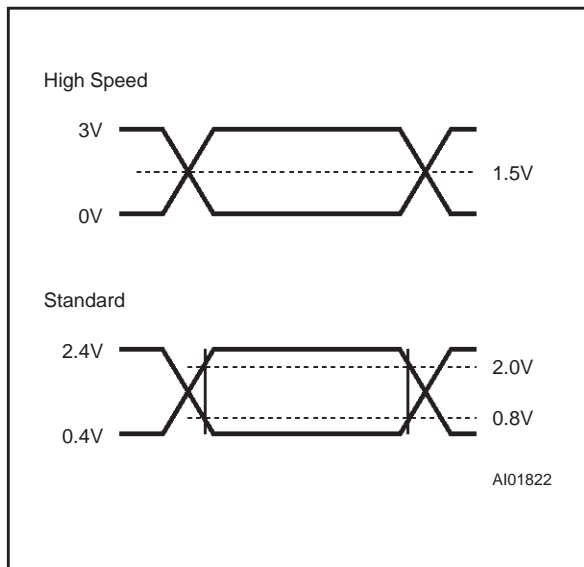

**Figure 4. AC Testing Load Circuit**

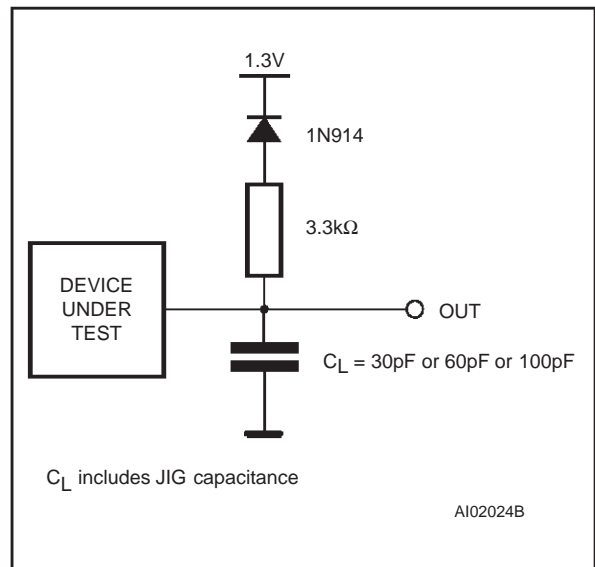

**Table 6. Capacitance (TA = 25 °C, f = 1 MHz)**

Symbol	Parameter	Test Condition	Min	Max	Unit
C <sub>IN</sub>	Input Capacitance	V <sub>IN</sub> = 0V		6	pF
C <sub>OUT</sub>	Output Capacitance	V <sub>OUT</sub> = 0V		12	pF

**Notes.** 1. V<sub>CC</sub> must be applied simultaneously with or before V<sub>PP</sub> and removed simultaneously with or after V<sub>PP</sub>.  
 2. This parameter is sampled only and not tested 100%.

**System Considerations**

The power switching characteristics of Advanced CMOS EPROMs require careful decoupling of the devices. The supply current, I<sub>CC</sub>, has three segments that are of interest to the system designer: the standby current level, the active current level, and transient current peaks that are produced by the falling and rising edges of  $\bar{E}$ . The magnitude of the transient current peaks is dependent on the capacitive and inductive loading of the device at the output. The associated transient voltage peaks can be suppressed by complying with the two line

output control and by properly selected decoupling capacitors. It is recommended that a 1μF ceramic capacitor be used on every device between V<sub>CC</sub> and V<sub>SS</sub>. This should be a high frequency capacitor of low inherent inductance and should be placed as close to the device as possible. In addition, a 4.7μF bulk electrolytic capacitor should be used between V<sub>CC</sub> and V<sub>SS</sub> for every eight devices. The bulk capacitor should be located near the power supply connection point. The purpose of the bulk capacitor is to overcome the voltage drop caused by the inductive effects of PCB traces.

**Table 7. Read Mode DC Characteristics (1)**(T<sub>A</sub> = 0 to 70 °C or -40 to 85 °C; V<sub>CC</sub> = 5V ± 5% or 5V ± 10%; V<sub>PP</sub> = V<sub>CC</sub>)

Symbol	Parameter	Test Condition	Min	Max	Unit
I <sub>LI</sub>	Input Leakage Current	0V ≤ V <sub>IN</sub> ≤ V <sub>CC</sub>		±1	μA
I <sub>LO</sub>	Output Leakage Current	0V ≤ V <sub>OUT</sub> ≤ V <sub>CC</sub>		±5	μA
I <sub>CC</sub>	Supply Current	$\bar{E} = V_{IL}, \bar{G} = V_{IL}, f = 5\text{MHz}$		30	mA
I <sub>CC1</sub>	Supply Current (Standby) TTL	$\bar{E} = V_{IH}$		1	mA
I <sub>CC2</sub>	Supply Current (Standby) CMOS	$\bar{E} > V_{CC} - 0.3\text{V}$		100	μA
I <sub>PP</sub>	Program Current	V <sub>PP</sub> = V <sub>CC</sub>		10	μA
V <sub>IL</sub>	Input Low Voltage		-0.3	0.8	V
V <sub>IH</sub> (2)	Input High Voltage		2	V <sub>CC</sub> + 1	V
V <sub>OL</sub>	Output Low Voltage	I <sub>OL</sub> = 2.1mA		0.4	V
V <sub>OH</sub>	Output High Voltage TTL	I <sub>OH</sub> = -400μA	2.4		V
	Output High Voltage CMOS	I <sub>OH</sub> = -100μA	V <sub>CC</sub> - 0.7V		V

**Notes:** 1. V<sub>CC</sub> must be applied simultaneously with or before V<sub>PP</sub> and removed simultaneously or after V<sub>PP</sub>.2. Maximum DC Voltage on Output is V<sub>CC</sub> + 0.5V.**Table 8A. Read Mode AC Characteristics (1)**(T<sub>A</sub> = 0 to 70 °C or -40 to 85 °C; V<sub>CC</sub> = 5V ± 5% or 5V ± 10%; V<sub>PP</sub> = V<sub>CC</sub>)

Symbol	Alt	Parameter	Test Condition	M27C516						Unit
				-35 (3)		-45 (3)		-55 (4)		
				Min	Max	Min	Max	Min	Max	
t <sub>AVQV</sub>	t <sub>ACC</sub>	Address Valid to Output Valid	$\bar{E} = V_{IL}, \bar{G} = V_{IL}$		35		45		55	ns
t <sub>ELQV</sub>	t <sub>CE</sub>	Chip Enable Low to Output Valid	$\bar{G} = V_{IL}$		35		45		55	ns
t <sub>GLQV</sub>	t <sub>OE</sub>	Output Enable Low to Output Valid	$\bar{E} = V_{IL}$		18		23		25	ns
t <sub>EHQZ</sub> (2)	t <sub>DF</sub>	Chip Enable High to Output Hi-Z	$\bar{G} = V_{IL}$	0	18	0	18	0	20	ns
t <sub>GHQZ</sub> (2)	t <sub>DF</sub>	Output Enable High to Output Hi-Z	$\bar{E} = V_{IL}$	0	18	0	18	0	20	ns
t <sub>AXQX</sub>	t <sub>OH</sub>	Address Transition to Output Transition	$\bar{E} = V_{IL}, \bar{G} = V_{IL}$	0		0		0		ns

**Notes:** 1. V<sub>CC</sub> must be applied simultaneously with or before V<sub>PP</sub> and removed simultaneously with or after V<sub>PP</sub>.

2. Sampled only, not 100% tested.

3. Speed obtained with High Speed measurement conditions and a load capacitance of 30pF.

4. Speed obtained with a load capacitance of 60pF.

## M27C516

**Table 8B. Read Mode AC Characteristics (1)**

( $T_A = 0$  to  $70$  °C or  $-40$  to  $85$  °C;  $V_{CC} = 5V \pm 5\%$  or  $5V \pm 10\%$ ;  $V_{PP} = V_{CC}$ )

Symbol	Alt	Parameter	Test Condition	M27C516				Unit
				-70 (3)		-85/-10		
				Min	Max	Min	Max	
$t_{AVQV}$	$t_{ACC}$	Address Valid to Output Valid	$\bar{E} = V_{IL}, \bar{G} = V_{IL}$		70		85	ns
$t_{ELQV}$	$t_{CE}$	Chip Enable Low to Output Valid	$\bar{G} = V_{IL}$		70		85	ns
$t_{GLQV}$	$t_{OE}$	Output Enable Low to Output Valid	$\bar{E} = V_{IL}$		35		35	ns
$t_{EHQZ}^{(2)}$	$t_{DF}$	Chip Enable High to Output Hi-Z	$\bar{G} = V_{IL}$	0	20	0	30	ns
$t_{GHQZ}^{(2)}$	$t_{DF}$	Output Enable High to Output Hi-Z	$\bar{E} = V_{IL}$	0	20	0	30	ns
$t_{AXQX}$	$t_{OH}$	Address Transition to Output Transition	$\bar{E} = V_{IL}, \bar{G} = V_{IL}$	0		0		ns

**Notes:** 1.  $V_{CC}$  must be applied simultaneously with or before  $V_{PP}$  and removed simultaneously with or after  $V_{PP}$ .  
 2. Sampled only, not 100% tested.  
 3. Speed obtained with a load capacitance of 60pF

**Figure 5. Read Mode AC Waveforms**

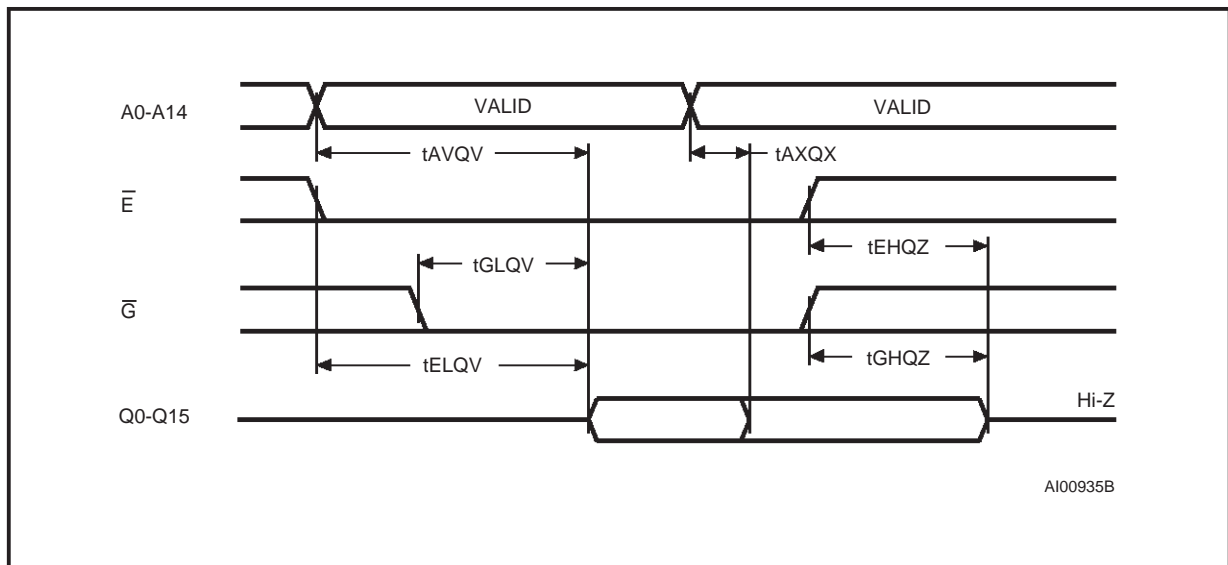

### Programming

When delivered, all bits of the M27C516 are in the '1' state. Data is introduced by selectively programming '0's into the desired bit locations. Although only '0's will be programmed, both '1's and '0's can be present in the data word. The M27C516 is in the

programming mode when  $V_{PP}$  input is at 12.75V,  $\bar{E}$  is at  $V_{IL}$  and  $\bar{P}$  is pulsed to  $V_{IL}$ . The data to be programmed is applied to 16 bits in parallel to the data output pins. The levels required for the address and data inputs are TTL.  $V_{CC}$  is specified to be  $6.25V \pm 0.25V$ .

**Table 9. Programming Mode DC Characteristics <sup>(1)</sup>**(T<sub>A</sub> = 25 °C; V<sub>CC</sub> = 6.25V ± 0.25V; V<sub>PP</sub> = 12.75V ± 0.25V)

Symbol	Parameter	Test Condition	Min	Max	Unit
I <sub>LI</sub>	Input Leakage Current	V <sub>IL</sub> ≤ V <sub>IN</sub> ≤ V <sub>IH</sub>		±10	μA
I <sub>CC</sub>	Supply Current			50	mA
I <sub>PP</sub>	Program Current	$\bar{E} = V_{IL}$		50	mA
V <sub>IL</sub>	Input Low Voltage		-0.3	0.8	V
V <sub>IH</sub>	Input High Voltage		2	V <sub>CC</sub> + 0.5	V
V <sub>OL</sub>	Output Low Voltage	I <sub>OL</sub> = 2.1mA		0.4	V
V <sub>OH</sub>	Output High Voltage TTL	I <sub>OH</sub> = -400μA	2.4		V
V <sub>ID</sub>	A9 Voltage		11.5	12.5	V

**Note:** 1. V<sub>CC</sub> must be applied simultaneously with or before V<sub>PP</sub> and removed simultaneously or after V<sub>PP</sub>.**Table 10. Programming Mode AC Characteristics <sup>(1)</sup>**(T<sub>A</sub> = 25 °C; V<sub>CC</sub> = 6.25V ± 0.25V; V<sub>PP</sub> = 12.75V ± 0.25V)

Symbol	Alt	Parameter	Test Condition	Min	Max	Unit
t <sub>AVPL</sub>	t <sub>AS</sub>	Address Valid to Program Low		2		μs
t <sub>QVPL</sub>	t <sub>DS</sub>	Input Valid to Program Low		2		μs
t <sub>VPHPL</sub>	t <sub>VPS</sub>	V <sub>PP</sub> High to Program Low		2		μs
t <sub>VCHPL</sub>	t <sub>VCS</sub>	V <sub>CC</sub> High to Program Low		2		μs
t <sub>ELPL</sub>	t <sub>CES</sub>	Chip Enable Low to Program Low		2		μs
t <sub>PLPH</sub>	t <sub>PW</sub>	Program Pulse Width		95	105	μs
t <sub>PHQX</sub>	t <sub>DH</sub>	Program High to Input Transition		2		μs
t <sub>QXGL</sub>	t <sub>OES</sub>	Input Transition to Output Enable Low		2		μs
t <sub>GLQV</sub>	t <sub>OE</sub>	Output Enable Low to Output Valid			100	ns
t <sub>GHQZ</sub> <sup>(2)</sup>	t <sub>DFP</sub>	Output Enable High to Output Hi-Z		0	130	ns
t <sub>GHAX</sub>	t <sub>AH</sub>	Output Enable High to Address Transition		0		μs

**Notes:** 1. V<sub>CC</sub> must be applied simultaneously with or before V<sub>PP</sub> and removed simultaneously or after V<sub>PP</sub>.

2. Sampled only and not 100% tested.

Figure 6. Programming and Verify Modes AC Waveforms

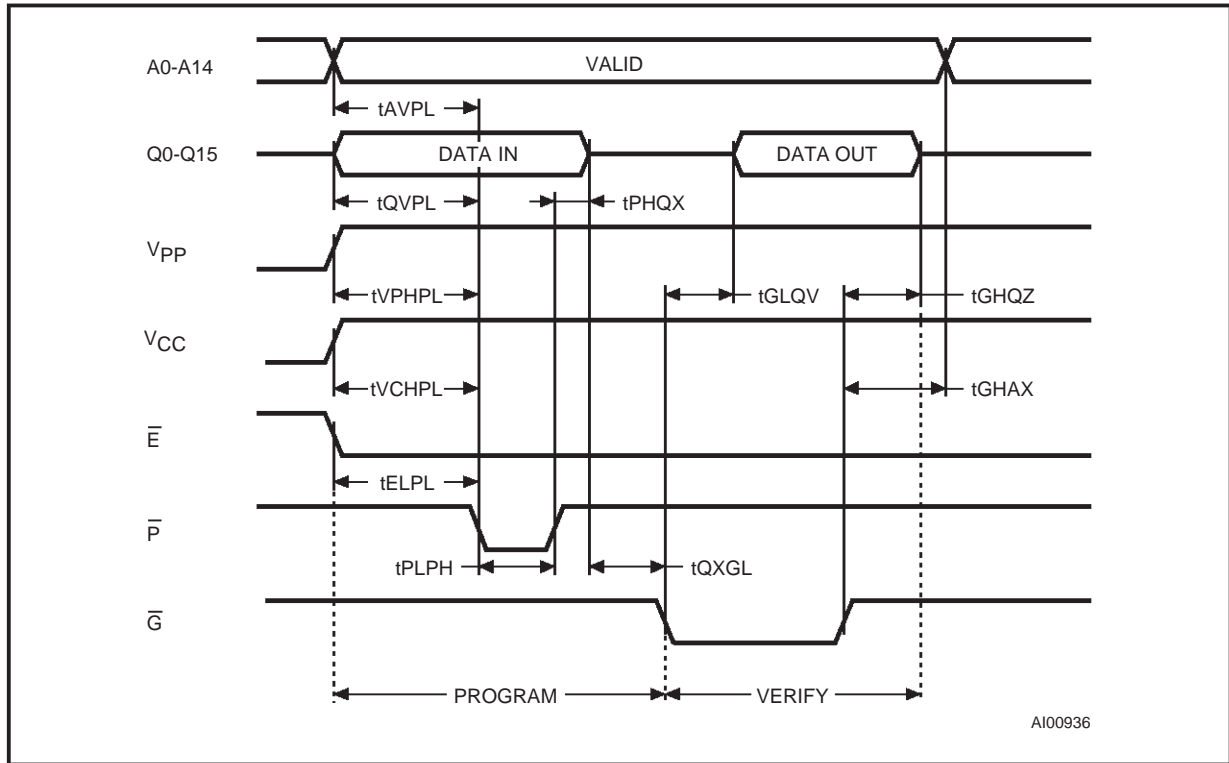

AI00936

Figure 7. Programming Flowchart

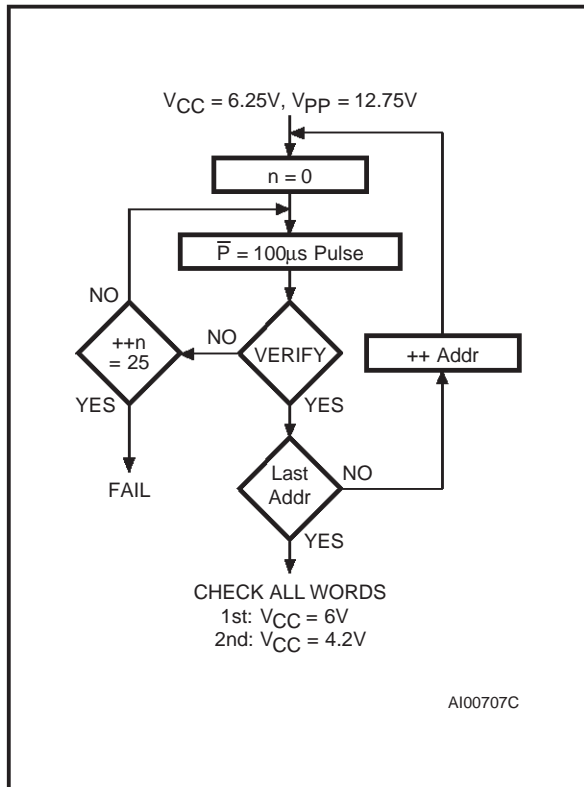

AI00707C

**PRESTO II Programming Algorithm**

PRESTO II Programming Algorithm allows to program the whole array with a guaranteed margin, in a typical time of 3 seconds. Programming with PRESTO II involves the application of a sequence of 100µs program pulses to each byte until a correct verify occurs (see Figure 7). During programming and verify operation, a MARGIN MODE circuit is automatically activated in order to guarantee that each cell is programmed with enough margin. No overprogram pulse is applied since the verify in MARGIN MODE provides necessary margin to each programmed cell.

**Program Inhibit**

Programming of multiple M27C516s in parallel with different data is also easily accomplished. Except for  $\bar{E}$ , all like inputs including  $\bar{G}$  of the parallel M27C516 may be common. A TTL low level pulse applied to a M27C516's  $\bar{P}$  input, with  $\bar{E}$  low and V<sub>PP</sub> at 12.75V, will program that M27C516. A high level  $\bar{E}$  input inhibits the other M27C516s from being programmed.

**Program Verify**

A verify (read) should be performed on the programmed bits to determine that they were correctly programmed. The verify is accomplished with  $\bar{E}$  and  $\bar{G}$  at V<sub>IL</sub>,  $\bar{P}$  at V<sub>IH</sub>, V<sub>PP</sub> at 12.75V and V<sub>CC</sub> at 6.25V.



**On-Board Programming**

The M27C516 can be directly programmed in the application circuit. See the relevant Application Note AN620.

**Electronic Signature**

The Electronic Signature (ES) mode allows the reading out of a binary code from an EPROM that will identify its manufacturer and type. This mode is intended for use by programming equipment to automatically match the device to be programmed with its corresponding programming algorithm. The ES mode is functional in the 25°C ± 5°C ambient temperature range that is required when program-

ming the M27C516. To activate the ES mode, the programming equipment must force 11.5V to 12.5V on address line A9 of the M27C516.

Two identifier bytes may then be sequenced from the device outputs by toggling address line A0 from V<sub>IL</sub> to V<sub>IH</sub>. All other address lines must be held at V<sub>IL</sub> during Electronic Signature mode. Byte 0 (A0=V<sub>IL</sub>) represents the manufacturer code and byte 1 (A0=V<sub>IH</sub>) the device identifier code. For the STMicroelectronics M27C516, these two identifier bytes are given in Table 4 and can be read-out on outputs Q0 to Q7.

**ORDERING INFORMATION SCHEME**

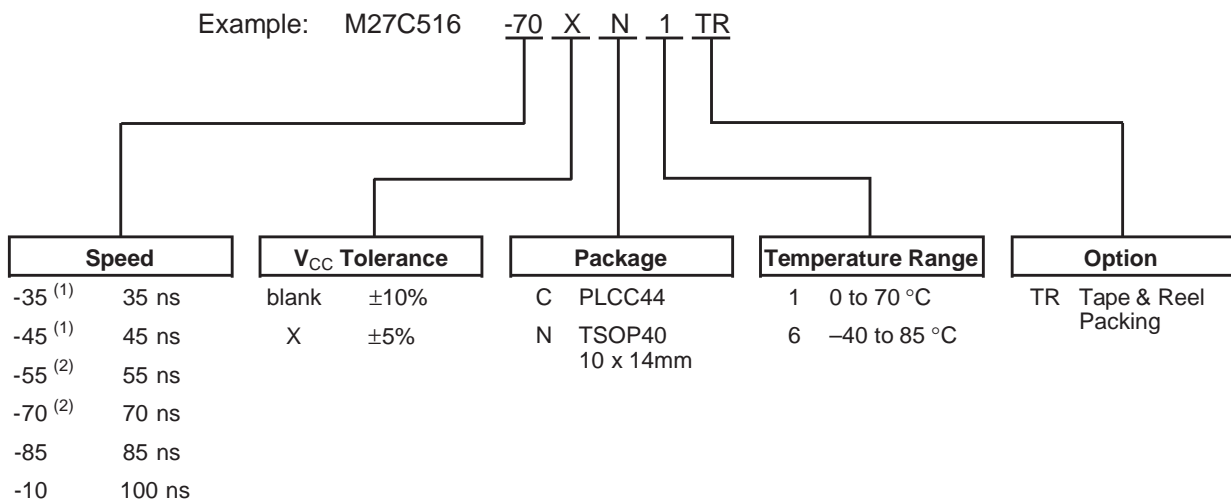

Notes: 1. High Speed, see AC Characteristics section for further information.  
2. Speed obtained with a load capacitance of 60pF.

For a list of available options (Speed, Package, etc...) or for further information on any aspect of this device, please contact the STMicroelectronics Sales Office nearest to you.

**PLCC44 - 44 lead Plastic Leaded Chip Carrier, square**

Symb	mm			inches		
	Typ	Min	Max	Typ	Min	Max
A		4.20	4.70		0.165	0.185
A1		2.29	3.04		0.090	0.120
A2		–	0.51		–	0.020
B		0.33	0.53		0.013	0.021
B1		0.66	0.81		0.026	0.032
D		17.40	17.65		0.685	0.695
D1		16.51	16.66		0.650	0.656
D2		14.99	16.00		0.590	0.630
E		17.40	17.65		0.685	0.695
E1		16.51	16.66		0.650	0.656
E2		14.99	16.00		0.590	0.630
e	1.27	–	–	0.050	–	–
F		0.00	0.25		0.000	0.010
R	0.89	–	–	0.035	–	–
N	44			44		
CP			0.10			0.004

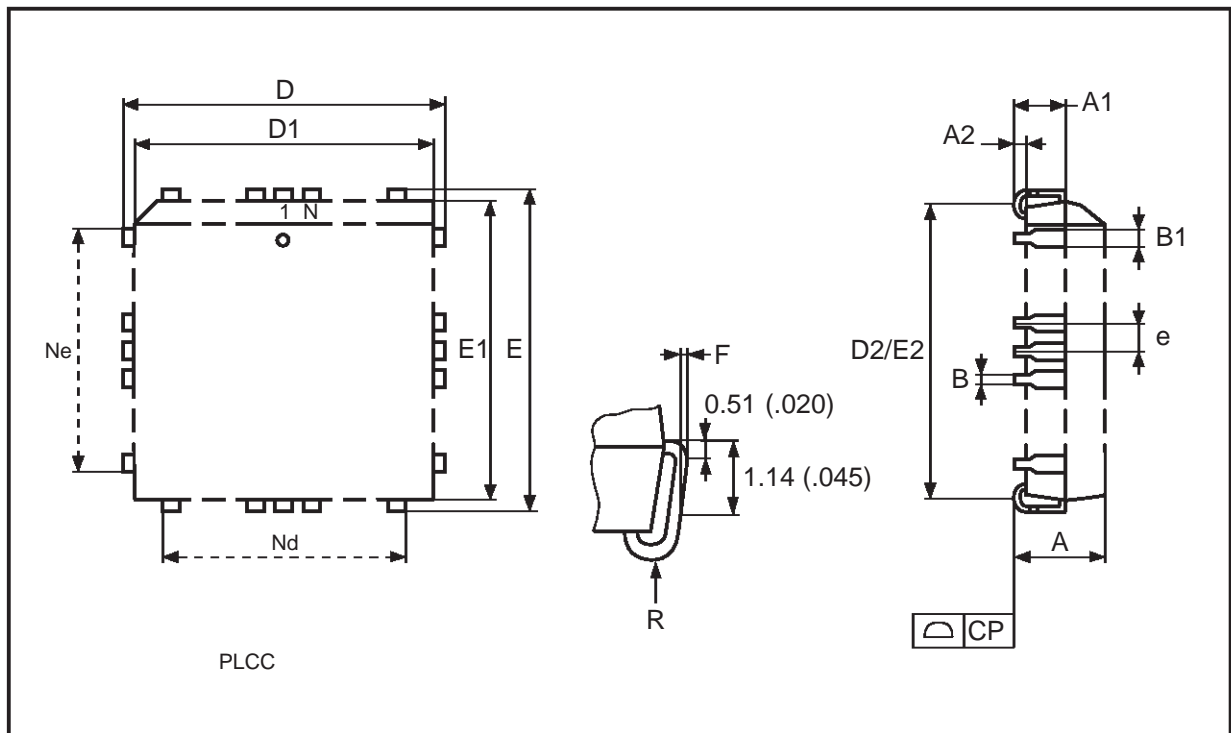

Drawing is not to scale

### TSOP40 - 40 lead Plastic Thin Small Outline, 10 x 14mm

Symb	mm			inches		
	Typ	Min	Max	Typ	Min	Max
A			1.20			0.047
A1		0.05	0.15		0.002	0.006
A2		0.95	1.05		0.037	0.041
B		0.17	0.27		0.007	0.011
C		0.10	0.21		0.004	0.008
D		13.80	14.20		0.543	0.559
D1		12.30	12.50		0.484	0.492
E		9.90	10.10		0.390	0.398
e	0.50	–	–	0.020	–	–
L		0.50	0.70		0.020	0.028
$\alpha$		0°	5°		0°	5°
N	40			40		
CP			0.10			0.004

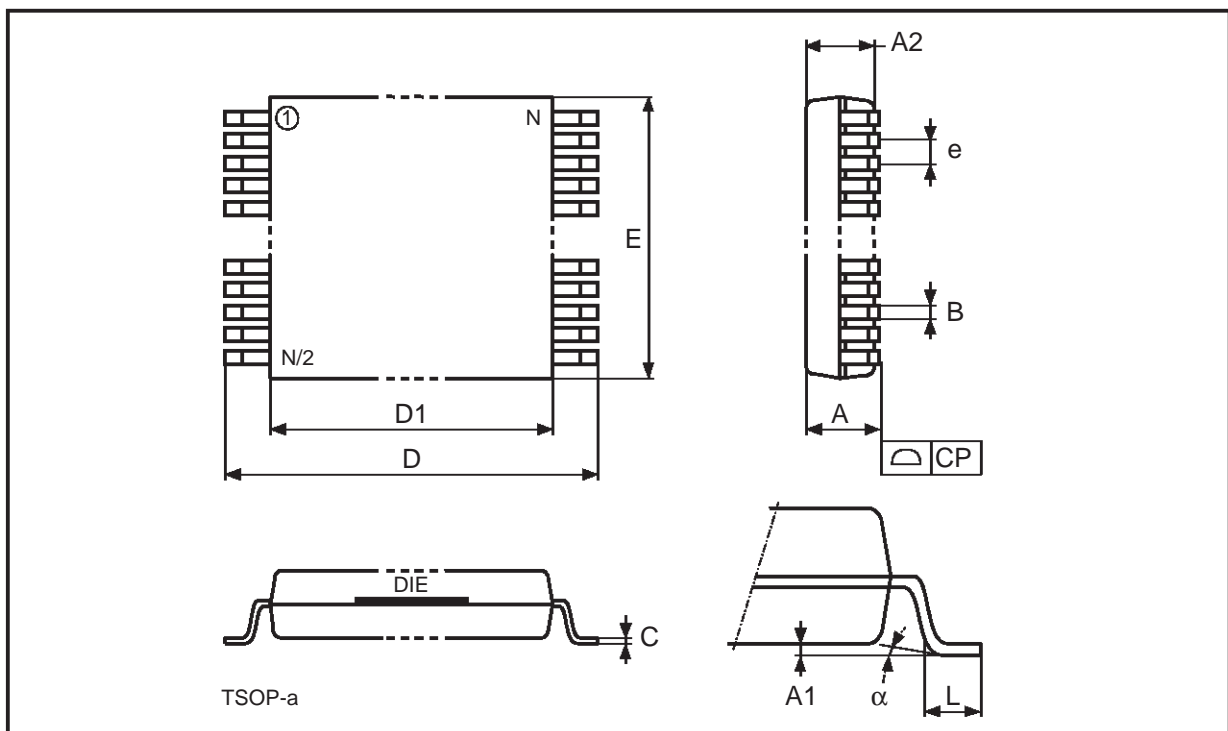

Drawing is not to scale

Information furnished is believed to be accurate and reliable. However, STMicroelectronics assumes no responsibility for the consequences of use of such information nor for any infringement of patents or other rights of third parties which may result from its use. No license is granted by implication or otherwise under any patent or patent rights of STMicroelectronics. Specifications mentioned in this publication are subject to change without notice. This publication supersedes and replaces all information previously supplied. STMicroelectronics products are not authorized for use as critical components in life support devices or systems without express written approval of STMicroelectronics.

The ST logo is a registered trademark of STMicroelectronics

© 1998 STMicroelectronics - All Rights Reserved

STMicroelectronics GROUP OF COMPANIES

Australia - Brazil - Canada - China - France - Germany - Italy - Japan - Korea - Malaysia - Malta - Mexico - Morocco - The Netherlands - Singapore - Spain - Sweden - Switzerland - Taiwan - Thailand - United Kingdom - U.S.A.