



2.5V MICROPOWER SHUNT VOLTAGE REFERENCE

- 2.50V TYP. OUTPUT VOLTAGE
- ULTRA LOW CURRENT CONSUMPTION:
40µA TYP.
- HIGH PRECISION @ 25°C
±2% (Standard version)
±1% (A grade)
- HIGH STABILITY WHEN USED WITH
CAPACITIVE LOAD
- INDUSTRIAL TEMPERATURE RANGE:
-40 to +85°C
- 100ppm/°C MAXIMUM TEMPERATURE
COEFFICIENT

DESCRIPTION

The TS822 is a low power shunt voltage reference providing a stable 2.5V output voltage over the industrial temperature range (-40 to +85°C). Available in SOT23-3 surface mount package, it can be designed in applications where space saving is a critical issue.

The low operating current is a key advantage for power restricted designs. In addition, the TS822 is very stable and can be used in a broad range of application conditions.

APPLICATION

- Computers
- Instrumentation
- Battery chargers
- Switch Mode Power Supply
- Battery operated equipments

ORDER CODE

Precision	TO92	SOT23-3	SOT23 Marking
2%	TS822IZ	TS822IL	L223
1%	TS822AIZ	TS822AIL	L222

Single temperature range: -40 to +85°C

Z = TO92 Plastic package

LT = Tiny Package (SOT23-5) - only available in Tape & Reel (LT)

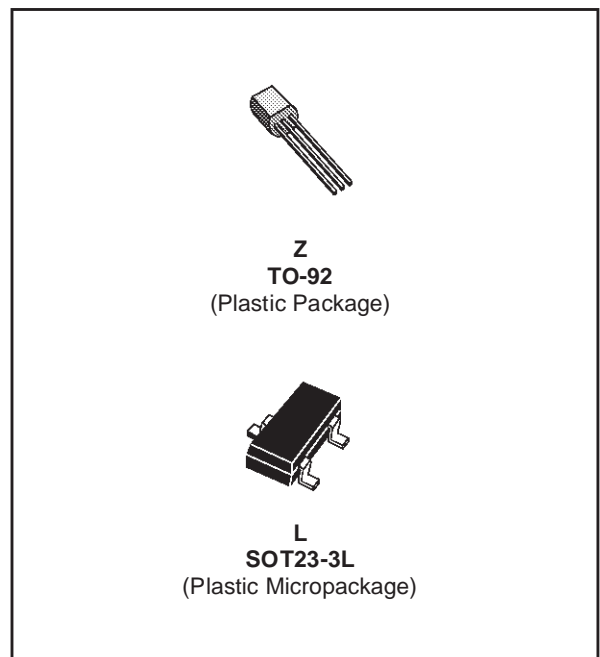

PIN CONNECTIONS (top view)

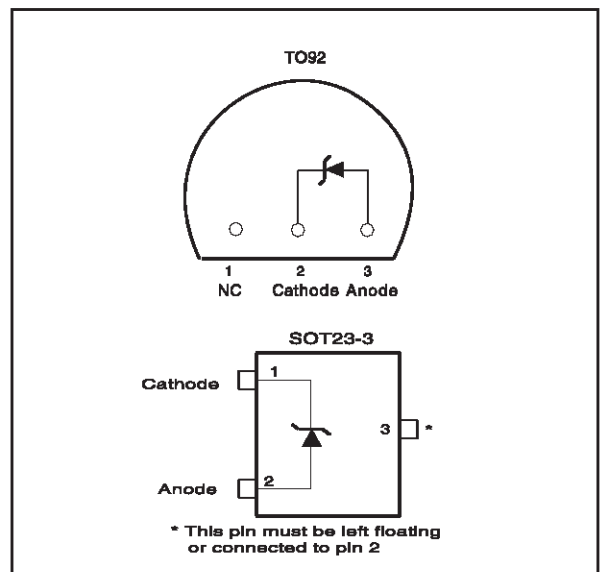

ABSOLUTE MAXIMUM RATINGS

Symbol	Parameter	Value	Unit
I_k	Reverse Breakdown Current	20	mA
I_f	Forward Current	10	mA
P_d	Power Dissipation ¹⁾ SOT23-3 TO-92	360 625	mW
T_{oper}	Operating Free Air Temperature Range	-40 to +85	°C
T_{std}	Storage Temperature	-65 to +150	°C
ESD	Human Body Model (HBM)	2	kV
	Machine Model (MM)	200	V
T_{lead}	Lead Temperature (soldering, 10 seconds)	260	°C

1. P_d has been calculated with $T_{amb} = 25^{\circ}\text{C}$ and $R_{thja} = 200^{\circ}\text{C/W}$ for the TO92 package
 $R_{thja} = 340^{\circ}\text{C/W}$ for the STO23-3L package

OPERATING CONDITIONS

Symbol	Parameter	Value	Unit
I_{kmin}	Minimum Operating Current	50	μA
I_{kmax}	Maximum Operating Current	15	mA

TS822

ELECTRICAL CHARACTERISTICS

TS822 (2% Precision)

Tamb = 25°C (unless otherwise specified)

Symbol	Parameter	Test Condition	Min.	Typ.	Max.	Unit
Vk	Reverse Breakdown Voltage	Ik = 100μA	2.45	2.5	2.55	V
	Reverse Breakdown Voltage Tolerance	Ik = 100μA -40°C < T < +85°C	-50 -66		50 66	mV
Ikmin	Minimum Operating Current	T = 25°C		40	50	μA
		-40°C < T < +85°C			60	
ΔVref/ΔT	Average Temperature Coefficient	Ik = 100μA		30	100	ppm/°C
ΔVk/ΔIk	Reverse Breakdown Voltage Change with Operating Current Range	Ikmin < Ik < 1mA -40°C < T < +85°C		0.4	1 1.2	mV
		1mA < Ik < 15mA -40°C < T < +85°C		2.5	8 10	
Rka	Reverse Static Impedance	Ik = Ikmin to 1mA -40°C < T < +85°C		0.4	1 1.2	Ω
		Ik = 1 to 15mA -40°C < T < +85°C		0.2	0.6 0.7	
Kvh	Long Term Stability	Ik = 100μA, t = 1000hrs		120		ppm
En	Wide Band Noise	Ik = 100μA 10Hz < f < 10kHz		35		μVrms

Note : Limits are 100% production tested at 25°C. Limits over temperature are guaranteed through correlation and by design.

ELECTRICAL CHARACTERISTICS

TS822A (1% Precision)

Tamb = 25°C (unless otherwise specified)

Symbol	Parameter	Test Condition	Min.	Typ.	Max.	Unit
Vk	Reverse Breakdown Voltage	Ik = 100μA	2.475	2.5	2.525	V
	Reverse Breakdown Voltage Tolerance	Ik = 100μA -40°C < T < +85°C	-25 -41		25 41	mV
Ikmin	Minimum Operating Current	T = 25°C		40	50	μA
		-40°C < T < +85°C			60	
ΔVref/ΔT	Average Temperature Coefficient	Ik = 100μA		30	100	ppm/°C
ΔVk/ΔIk	Reverse Breakdown Voltage Change with Operating Current Range	Ikmin < Ik < 1mA -40°C < T < +85°C		0.4	1 1.2	mV
		1mA < Ik < 15mA -40°C < T < +85°C		2.5	8 10	
Rka	Reverse Static Impedance	Ik = Ikmin to 1mA -40°C < T < +85°C		0.4	1 1.2	Ω
		Ik = 1mA to 15mA -40°C < T < +85°C		0.2	0.6 0.7	
Kvh	Long Term Stability	Ik = 100μA, t = 1000hrs		120		ppm
En	Wide Band Noise	Ik = 100μA 10Hz < f < 10kHz		35		μVrms

Note : Limits are 100% production tested at 25°C. Limits over temperature are guaranteed through correlation and by design.

Reference voltage versus cathode current

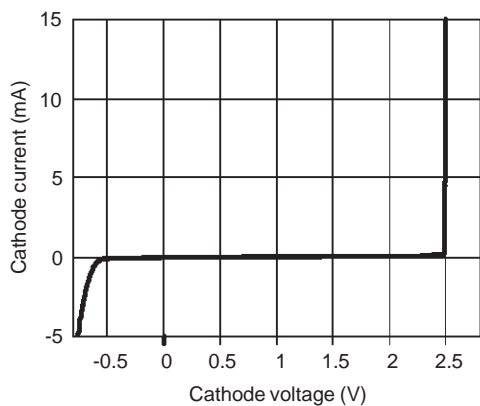

Minimum operating current

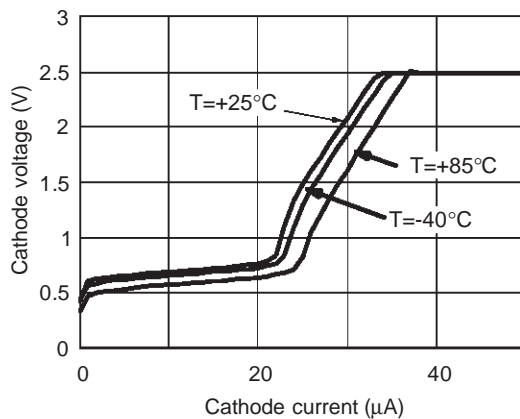

Test circuit

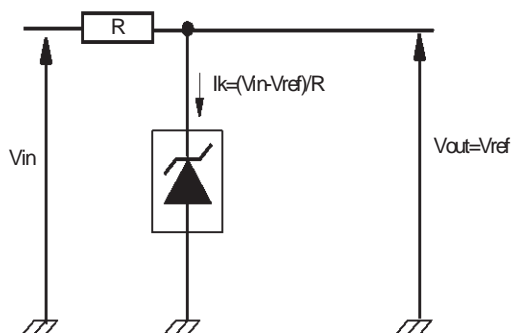

Reference voltage versus Temperature

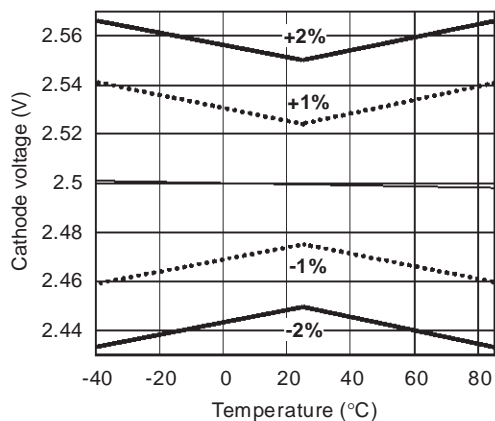

Static impedance (Rka) versus temperature

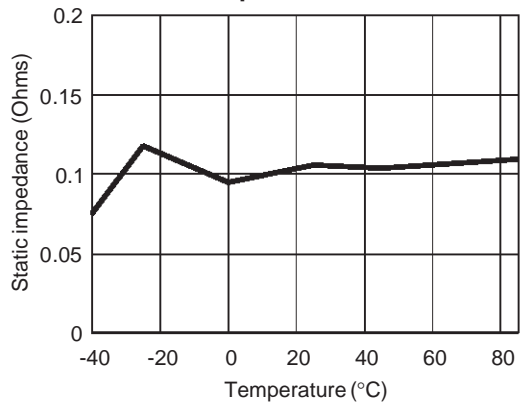

Noise voltage versus Frequency

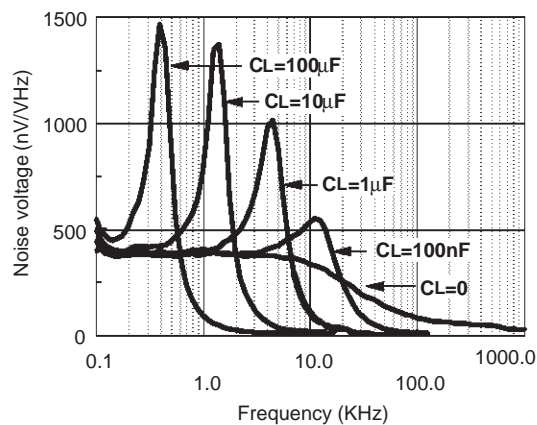

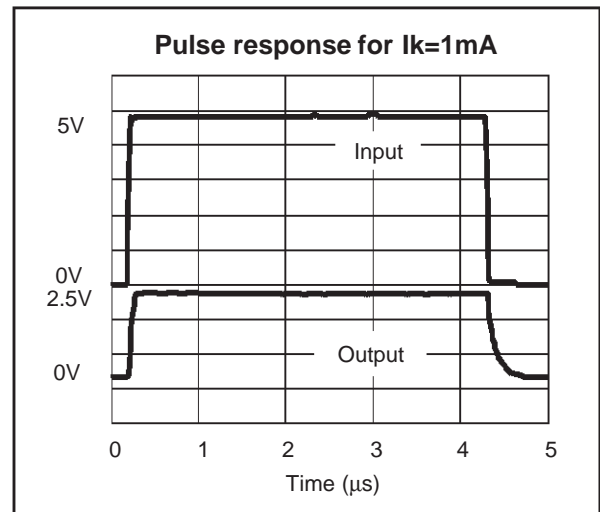
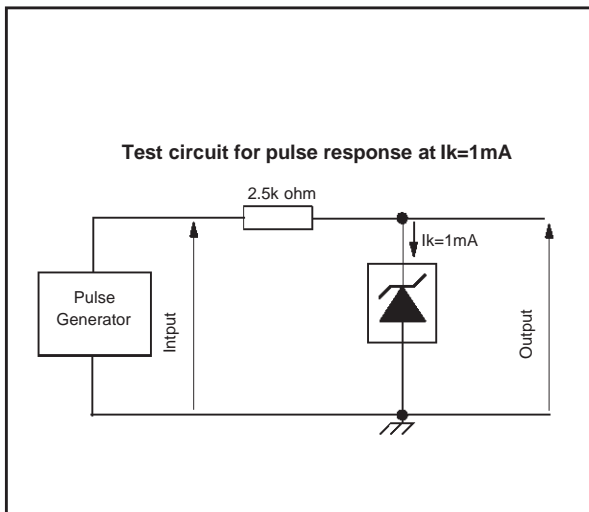
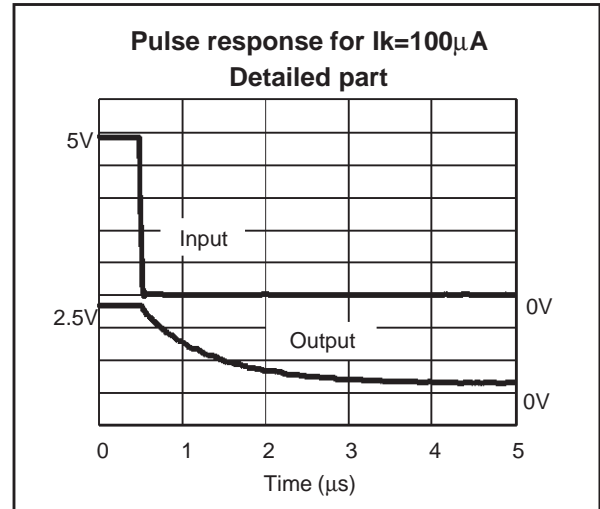
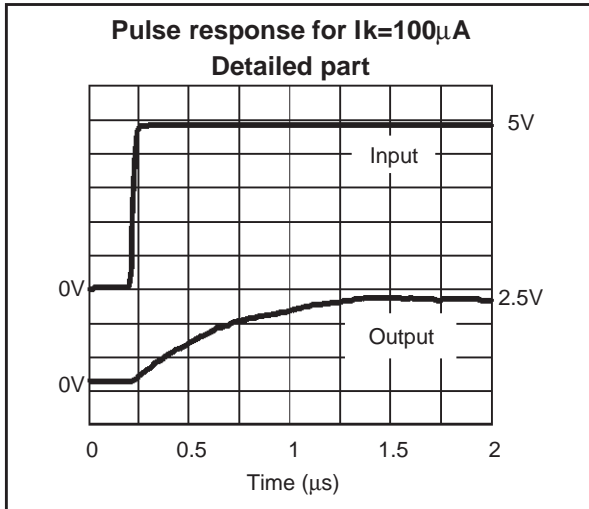
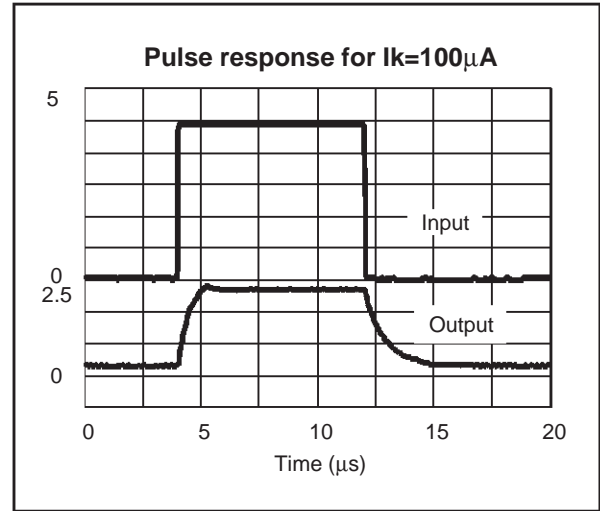
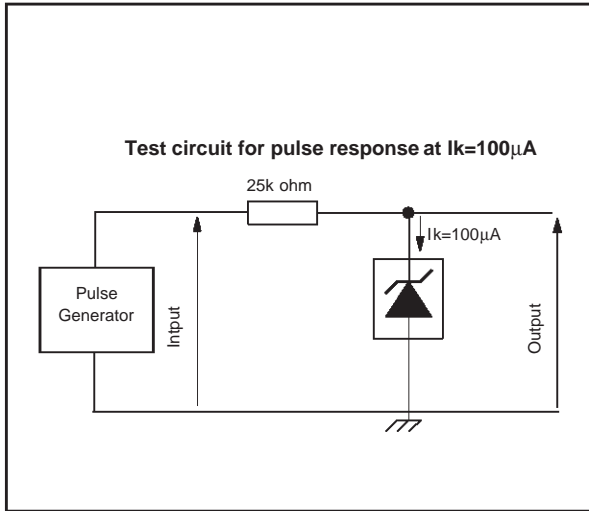

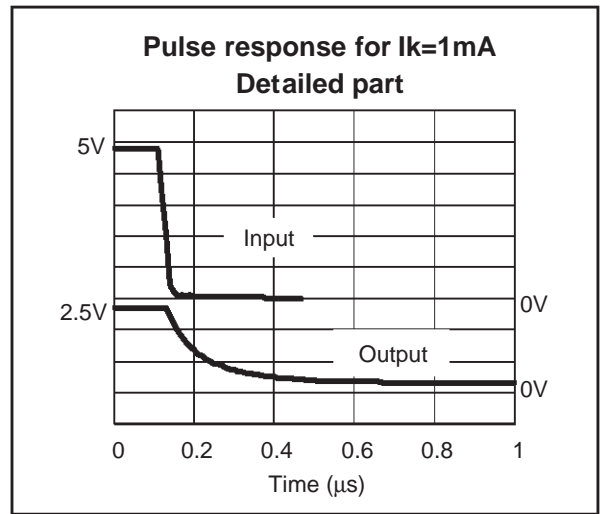
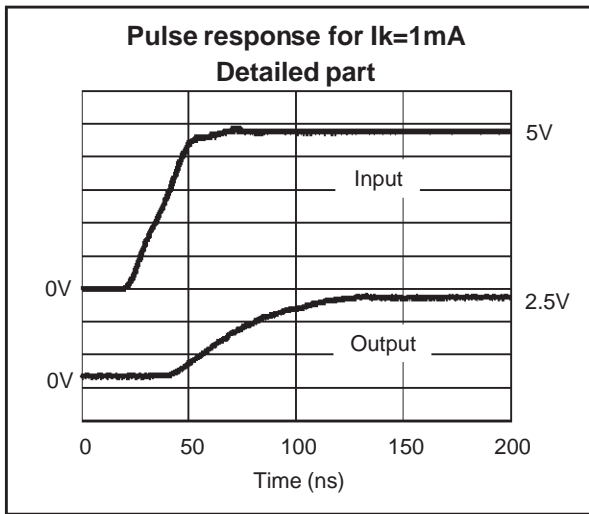

TS822

PACKAGE MECHANICAL DATA
3 PINS - PLASTIC PACKAGE TO-92

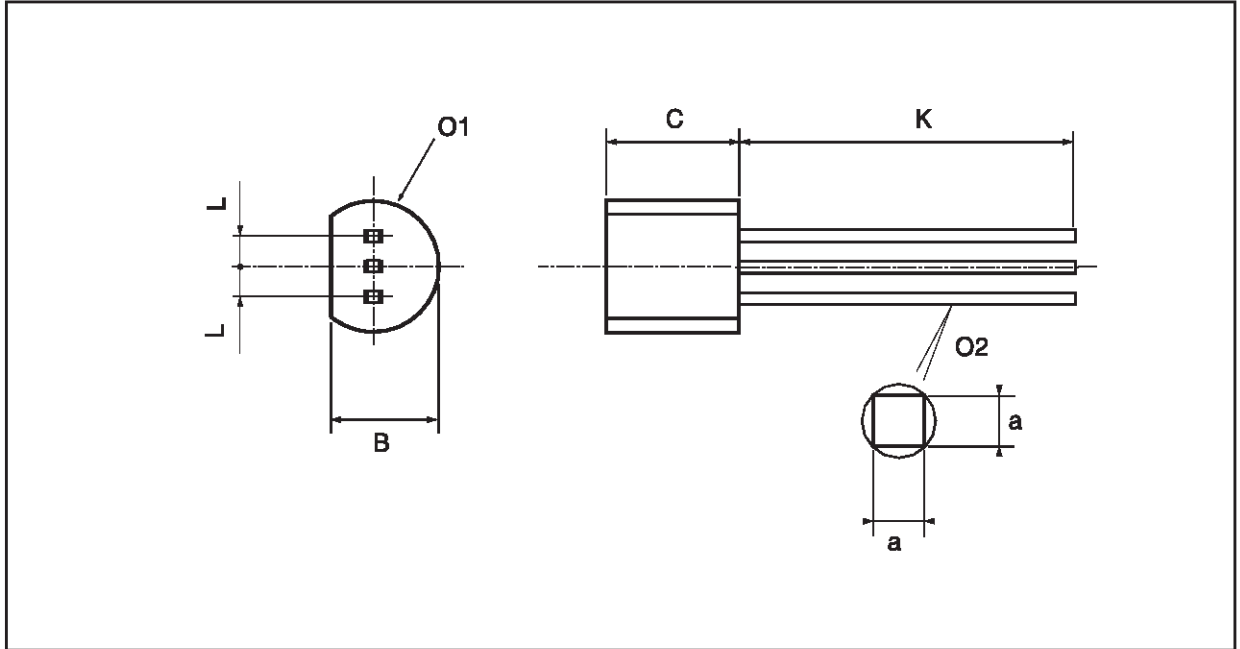

Dim.	Millimeters			Inches		
	Min	Typ.	Max.	Min.	Typ.	Max.
L		1.27			0.05	
B	3.2	3.7	4.2	0.126	0.1457	0.1654
O1	4.45	5.00	5.2	0.1752	0.1969	0.2047
C	4.58	5.03	5.33	0.1803	0.198	0.2098
K	12.7			0.5		
O2	0.407	0.5	0.508	0.016	0.0197	0.02
a	0.35			0.0138		

PACKAGE MECHANICAL DATA
3 PINS - TINY PACKAGE (SOT-23)

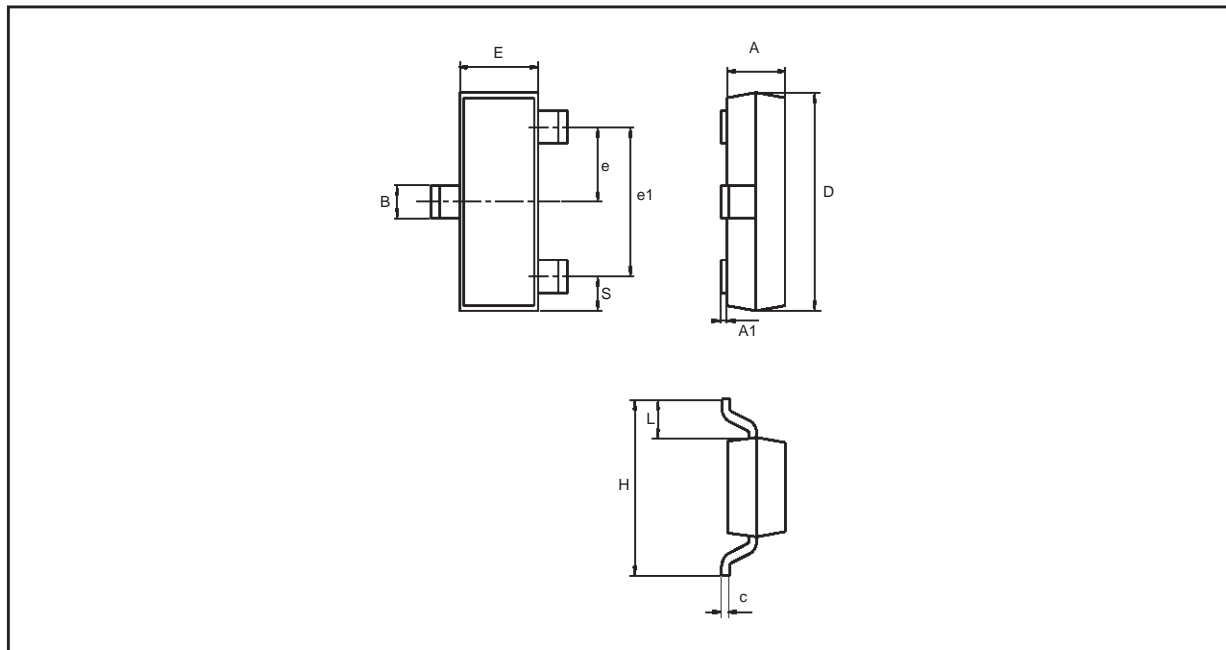

Dim.	Millimeters			Inches		
	Min.	Typ.	Max.	Min.	Typ.	Max.>
A	0.85		1.1	33.4		43.3
B	0.65		0.95	25.6		37.4
C	1.20		1.4	47.2		55.1
D	2.80		3	110.2		118
E	0.95		1.05	37.4		41.3
F	1.9		2.05	74.8		80.7
G	2.1		2.5	82.6		98.4
H	0.38		0.48	14.9		18.8
L	0.3		0.6	11.8		23.6
M	0		0.1	0		3.9
N	0.3		0.65	11.8		25.6
O	0.09		0.17	2.5		6.7

Information furnished is believed to be accurate and reliable. However, STMicroelectronics assumes no responsibility for the consequences of use of such information nor for any infringement of patents or other rights of third parties which may result from its use. No license is granted by implication or otherwise under any patent or patent rights of STMicroelectronics. Specifications mentioned in this publication are subject to change without notice. This publication supersedes and replaces all information previously supplied. STMicroelectronics products are not authorized for use as critical components in life support devices or systems without express written approval of STMicroelectronics.

© The ST logo is a registered trademark of STMicroelectronics

© 2000 STMicroelectronics - Printed in Italy - All Rights Reserved
STMicroelectronics GROUP OF COMPANIES

Australia - Brazil - China - Finland - France - Germany - Hong Kong - India - Italy - Japan - Malaysia - Malta - Morocco
Singapore - Spain - Sweden - Switzerland - United Kingdom

© <http://www.st.com>