

**VOICE COIL MOTOR DRIVER**

ADVANCE DATA

- OUTPUT CURRENT UP TO 1A
- OPERATES AT LOW VOLTAGES WITH LOW COIL RESISTANCE OF THE MOTOR
- LARGE COMMON MODE AND DIFFERENTIAL MODE RANGE
- LOW INPUT OFFSET VOLTAGE
- THERMAL SHUT-DOWN
- ENABLE FUNCTION
- INTERNAL CLAMP DIODES

**DESCRIPTION**

The L6242 is a monolithic integrated circuit in SO-20 package intended for use as a dual power operational amplifier. It is particularly indicated for driving inductive loads as linear motor, and finds application in Hard Disc, Compact-Disc, etc. The two power operational amplifiers are controlled by a common enable input.

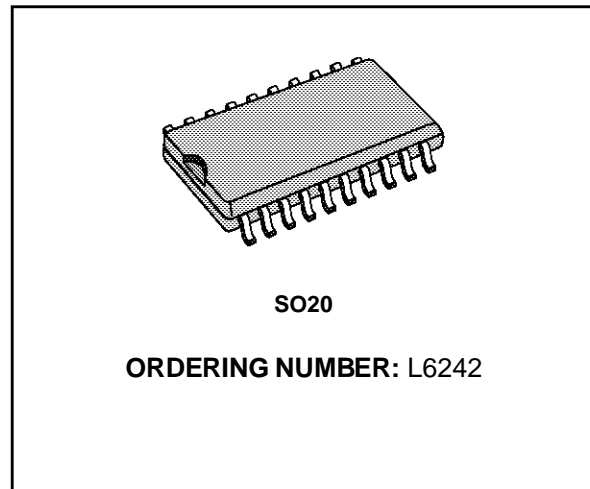

The high gain and output power capability provide superior performance whatever a power booster is required.

**PIN CONNECTION AND BLOCK DIAGRAM**

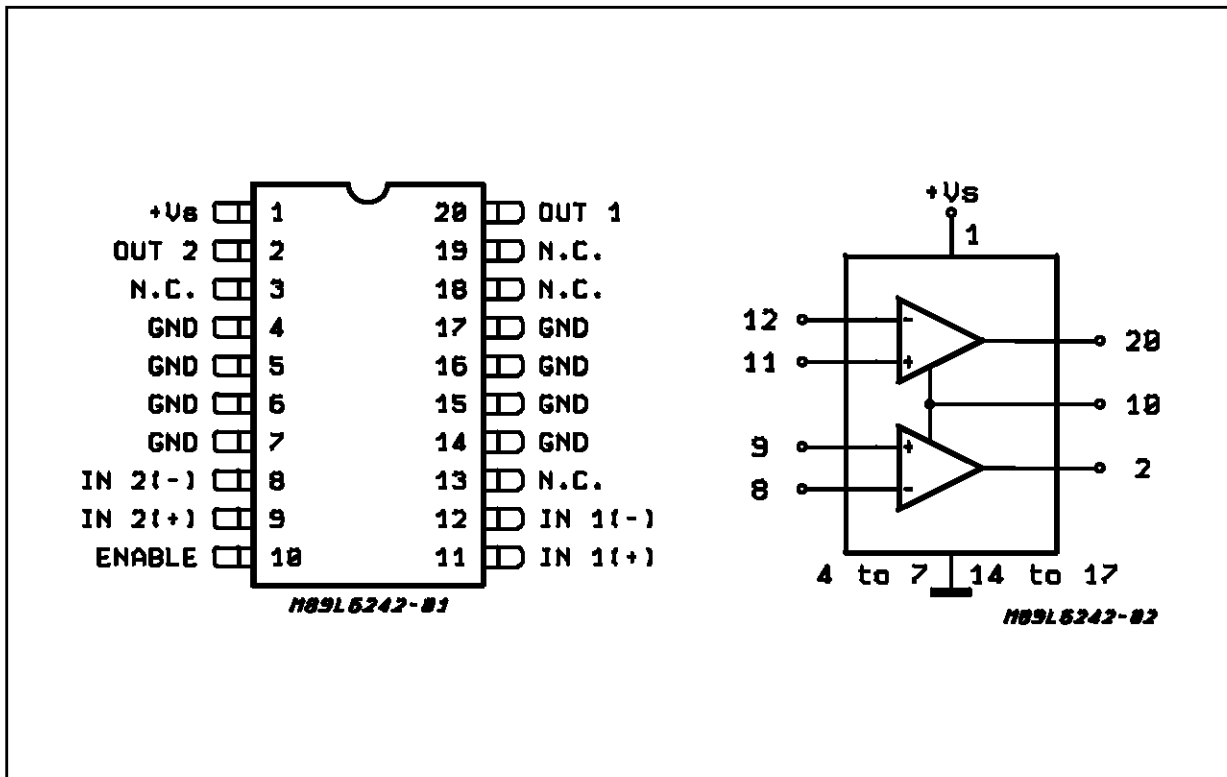

## ABSOLUTE MAXIMUM RATINGS

Symbol	Parameter	Value	Unit
V <sub>S</sub>	Supply Voltage	28	V
V <sub>i</sub>	Input Voltage	V <sub>S</sub>	V
V <sub>i</sub>	Differential Input Voltage	±V <sub>S</sub>	V
I <sub>O</sub>	DC Output Current	1	A
I <sub>P</sub>	Peak Output Current (non repetitive)	1.5	A
P <sub>tot</sub>	Maximum Power Dissipation at T <sub>amb</sub> = 85°C T <sub>CASE</sub> = 75°C	1 5	W W
T <sub>stg</sub> , T <sub>J</sub>	Storage and Junction Temperature Range	-40 to 150	°C

ELECTRICAL CHARACTERISTICS (V<sub>S</sub> = 12V, T<sub>J</sub> = 25°C unless otherwise specified)

Symbol	Parameter	Test Condition	Min.	Typ.	Max.	Unit
V <sub>S</sub>	Supply Voltage		4		28	V
I <sub>S</sub>	Quiescent Drain Current	V <sub>O</sub> = V <sub>S</sub> /2		10	15	mA
I <sub>b</sub>	Input Bias Current			0.2	1	μA
V <sub>OS</sub>	Input Offset Voltage				15	mV
I <sub>OS</sub>	Input Offset Current			10	50	nA
S <sub>r</sub>	Slew Rate			1.5		V/μs
R <sub>i</sub>	Input Resistance		500			KΩ
G <sub>V</sub>	Open Loop Voltage Gain	f = 100Hz	70	80		dB
CMR	Common Mode Rejection	f = 100Hz	66	84		dB
SVR	Supply Voltage Rejection	f = 100Hz R <sub>g</sub> = 10KΩ V <sub>r</sub> = 0.5V		54		dB
V <sub>drop</sub>	High Drop Voltage	I = 100mA I = 500mA		0.7 1	1.5	V V
V <sub>drop</sub>	Low Drop Voltage	I = 100mA I = 500mA		0.3 0.6	1	V V
T <sub>sd</sub>	Thermal Shutdown Junction Temperature			145		°C
R <sub>p</sub>	Internal Pull-up Resistor of the Enable Input				50	KΩ
V <sub>e</sub>	Enable Low Voltage	T <sub>J</sub> = 130°C	-0.3		1.2	V
I <sub>eq</sub>	Quiescent Drain Current	En = L		2	5	mA
T <sub>d</sub>	Enable Delay				50	μs
I <sub>ol</sub>	Output Leakage Current			10		μA

## APPLICATION INFORMATION

Figure 1 shows the L6242 configured as a transconductance amplifier, in order to drive linear motors as Voice Coil (VCM). The L6242 provides the power section of the Transconductance Amplifier. The two OP AMP are configured one as inverting and the other as noninverting amplifier, with the same gain. Working in push-pull, they can be configured as a bridge. The motor current can be controlled by means of the sense resistor (typical 1Ω) in series with the motor. The current sense amplifier provides the feedback signal, which is summed to the driving signal at the node which is the inverting input of the Error Am-

plifier. R1 closes the control loop. R2 converts the input voltage signal, into a current signal.

The snubber network provides the system stability, always required by the application. The network is directly connected to the output pins of the IC, OUT1 and OUT2, and in parallel with the load. R4 and C2 could be of different values, depending on the p.c.b. configuration and on the motor characteristics.

The DC transfer function may be expressed as:

$$gm = I_{out}/V_{in} = k \cdot (R1/R2)$$

$$\text{where } k = 1/(R_{sense} \cdot A_d)$$

and A<sub>d</sub> = gain of the current sense amplifier.



## SO20 PACKAGE MECHANICAL DATA

DIM.	mm			inch		
	MIN.	TYP.	MAX.	MIN.	TYP.	MAX.
A			2.65			0.104
a1	0.1		0.3	0.004		0.012
a2			2.45			0.096
b	0.35		0.49	0.014		0.019
b1	0.23		0.32	0.009		0.013
C		0.5			0.020	
c1	45 (typ.)					
D	12.6		13.0	0.496		0.512
E	10		10.65	0.394		0.419
e		1.27			0.050	
e3		11.43			0.450	
F	7.4		7.6	0.291		0.299
L	0.5		1.27	0.020		0.050
M			0.75			0.030
S	8 (max.)					

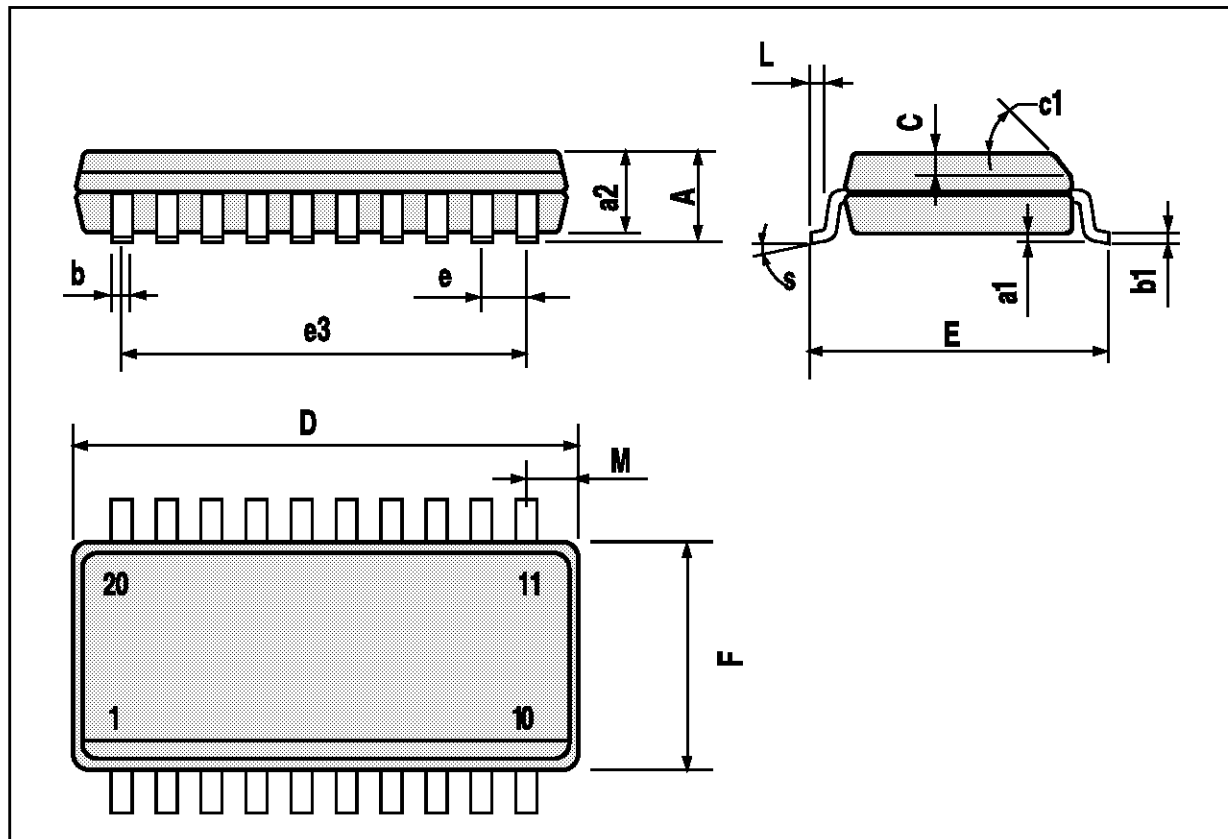

Information furnished is believed to be accurate and reliable. However, SGS-THOMSON Microelectronics assumes no responsibility for the consequences of use of such information nor for any infringement of patents or other rights of third parties which may result from its use. No license is granted by implication or otherwise under any patent or patent rights of SGS-THOMSON Microelectronics. Specifications mentioned in this publication are subject to change without notice. This publication supersedes and replaces all information previously supplied. SGS-THOMSON Microelectronics products are not authorized for use as critical components in life support devices or systems without express written approval of SGS-THOMSON Microelectronics.

© 1994 SGS-THOMSON Microelectronics - All Rights Reserved

SGS-THOMSON Microelectronics GROUP OF COMPANIES

Australia - Brazil - France - Germany - Hong Kong - Italy - Japan - Korea - Malaysia - Malta - Morocco - The Netherlands - Singapore - Spain - Sweden - Switzerland - Taiwan - Thailand - United Kingdom - U.S.A.