

GENERAL PURPOSE SINGLE OPERATIONAL AMPLIFIER

- LARGE INPUT VOLTAGE RANGE
- NO LATCH-UP
- HIGH GAIN
- SHORT-CIRCUIT PROTECTION
- NO FREQUENCY COMPENSATION REQUIRED
- SAME PIN CONFIGURATION AS THE UA709

DESCRIPTION

The UA741 is a high performance monolithic operational amplifier constructed on a single silicon chip. It is intended for a wide range of analog applications.

- Summing amplifier
- Voltage follower
- Integrator
- Active filter
- Function generator

The high gain and wide range of operating voltages provide superior performances in integrator, summing amplifier and general feedback applications. The internal compensation network (6dB/octave) insures stability in closed loop circuits.

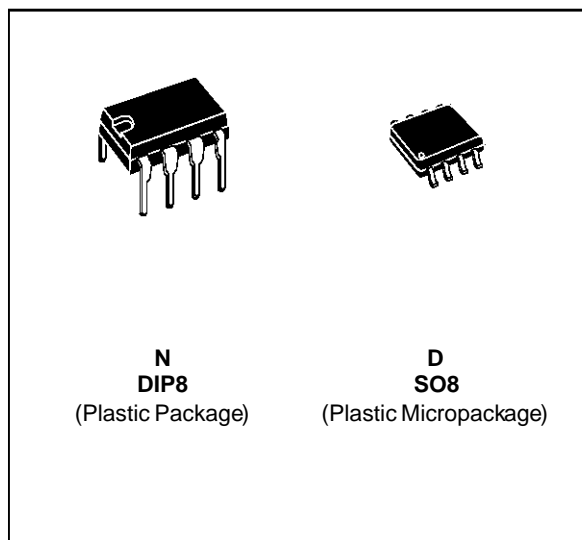

ORDER CODES

Part Number	Temperature Range	Package	
		N	D
UA741C	0°C, +70°C	•	•
UA741I	-40°C, +105°C	•	•
UA741M	-55°C, +125°C	•	•

Example : UA741CN

PIN CONNECTIONS (top view)

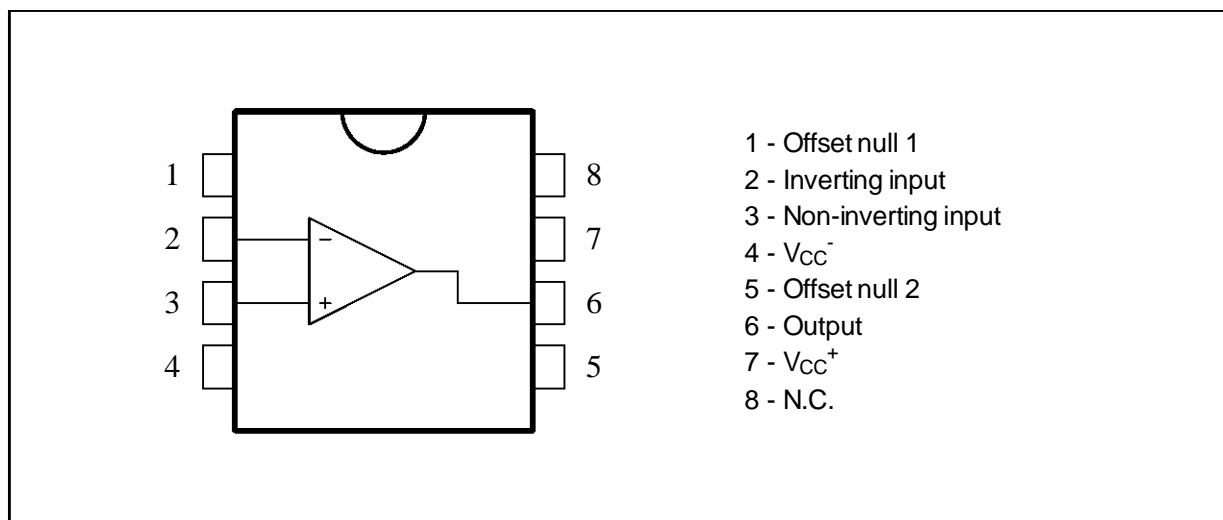

SCHEMATIC DIAGRAM

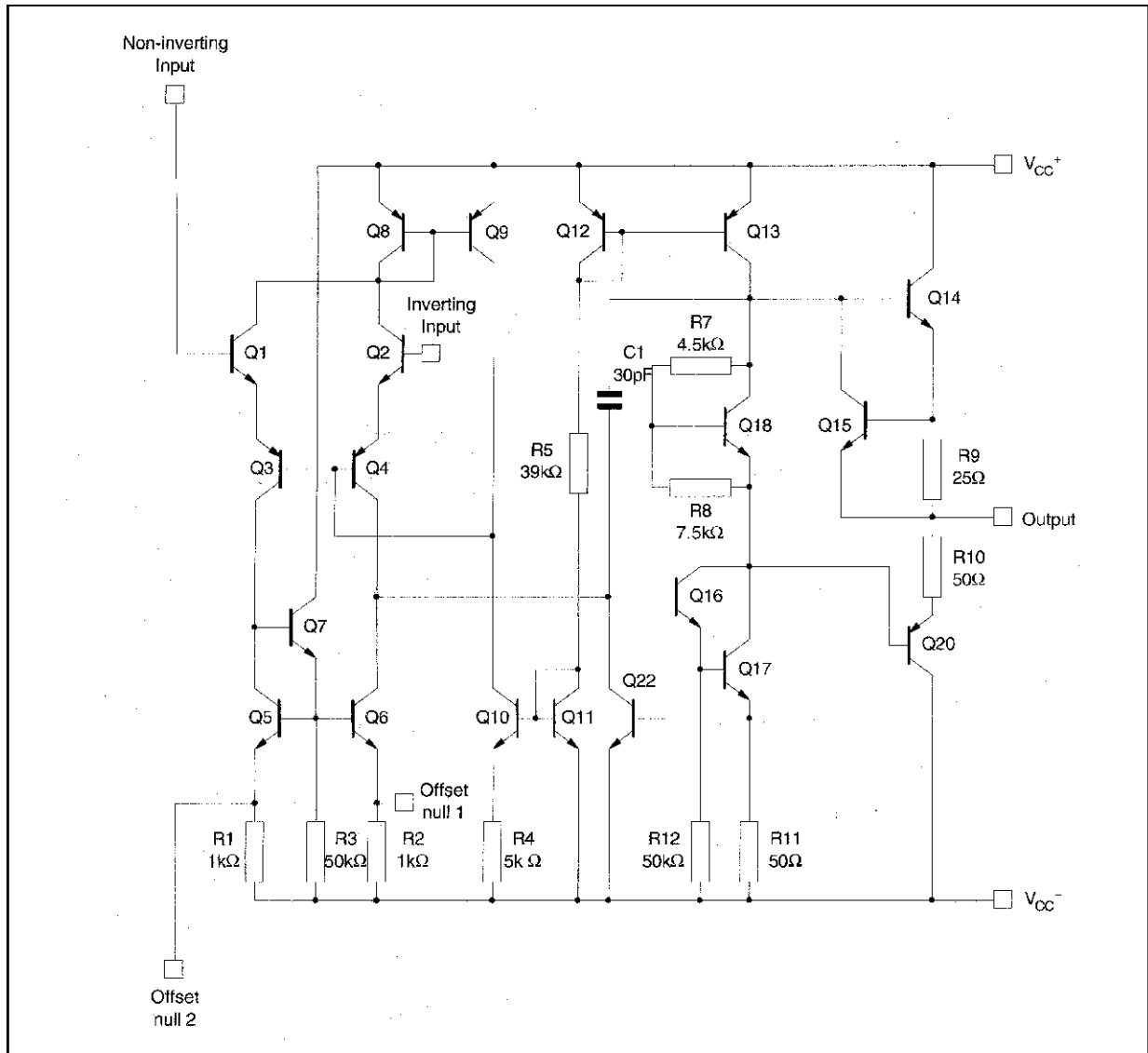

ABSOLUTE MAXIMUM RATINGS

Symbol	Parameter	UA741M	UA741I	UA741C	Unit
V_{cc}	Supply Voltage		± 22		V
V_{id}	Differential Input Voltage		± 30		V
V_i	Input Voltage		± 15		V
P_{tot}	Power Dissipation		500		mW
	Output Short-circuit Duration	Infinite			
T_{oper}	Operating Free Air Temperature Range	-55 to +125	-40 to +105	0 to +70	$^{\circ}C$
T_{stg}	Storage Temperature Range	-65 to +150	-65 to +150	-65 to +150	$^{\circ}C$

ELECTRICAL CHARACTERISTICS
 $V_{CC} = \pm 15V$, $T_{amb} = +25^{\circ}C$ (unless otherwise specified)

Symbol	Parameter	Min.	Typ.	Max.	Unit
V_{io}	Input Offset Voltage ($R_S \leq 10k\Omega$) $T_{amb} = +25^{\circ}C$ $T_{min.} \leq T_{amb} \leq T_{max.}$		1	5 6	mV
I_{io}	Input Offset Current $T_{amb} = +25^{\circ}C$ $T_{min.} \leq T_{amb} \leq T_{max.}$		2	30 70	nA
I_{ib}	Input Bias Current $T_{amb} = +25^{\circ}C$ $T_{min.} \leq T_{amb} \leq T_{max.}$		10	100 200	nA
A_{vd}	Large Signal Voltage Gain * ($V_O \pm 10V$, $R_L = 2k\Omega$) $T_{amb} = +25^{\circ}C$ $T_{min.} \leq T_{amb} \leq T_{max.}$	50 25	200		V/mV
SVR	Supply Voltage Rejection Ratio ($R_S \leq 10k\Omega$) $T_{amb} = +25^{\circ}C$ $T_{min.} \leq T_{amb} \leq T_{max.}$	77 77	90		dB
I_{CC}	Supply Current, no load $T_{amb} = +25^{\circ}C$ $T_{min.} \leq T_{amb} \leq T_{max.}$		1.7	2.8 3.3	mA
V_{icm}	Input Common Mode Voltage Range $T_{amb} = +25^{\circ}C$ $T_{min.} \leq T_{amb} \leq T_{max.}$	± 12 ± 12			V
CMR	Common-mode Rejection Ratio ($R_S \leq 10k\Omega$) $T_{amb} = +25^{\circ}C$ $T_{min.} \leq T_{amb} \leq T_{max.}$	70 70	90		dB
I_{OS}	Output Short-circuit Current	10	25	40	mA
$\pm V_{OPP}$	Output Voltage Swing $T_{amb} = +25^{\circ}C$ $T_{min.} \leq T_{amb} \leq T_{max.}$	$R_L = 10k\Omega$ 12 $R_L = 2k\Omega$ 10 $R_L = 10k\Omega$ 12 $R_L = 2k\Omega$ 10	14 13		V
SR	Slew Rate ($V_i = \pm 10V$, $R_L = 2k\Omega$, $C_L = 100pF$, $T_{amb} = 25^{\circ}C$, unity gain)	0.25	0.5		V/ μs
t_r	Rise Time ($V_i = \pm 20mV$, $R_L = 2k\Omega$, $C_L = 100pF$, $T_{amb} = 25^{\circ}C$, unity gain)		0.3		μs
K_{OV}	Overshoot ($V_i = 20mV$, $R_L = 2k\Omega$, $C_L = 100pF$, $T_{amb} = 25^{\circ}C$, unity gain)		5		%
R_i	Input Resistance	0.3	2		M Ω
GBP	Gain Bandwidth Product ($V_i = 10mV$, $R_L = 2k\Omega$, $C_L = 100pF$, $f = 100kHz$)	0.7	1		MHz
THD	Total Harmonic Distortion ($f = 1kHz$, $A_V = 20dB$, $R_L = 2k\Omega$, $V_O = 2V_{PP}$, $C_L = 100pF$, $T_{amb} = 25^{\circ}C$)		0.06		%
e_n	Equivalent Input Noise Voltage ($f = 1kHz$, $R_S = 100\Omega$)		23		$\frac{nV}{\sqrt{Hz}}$
ϕ_m	Phase Margin		50		Degrees

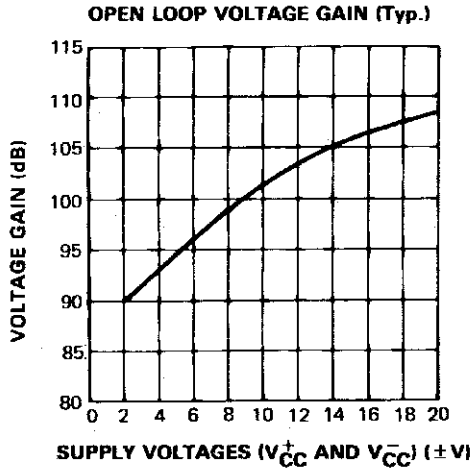

741-04.EPS

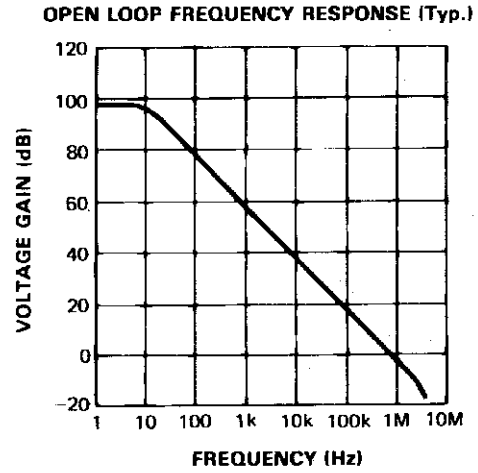

741-05.EP.

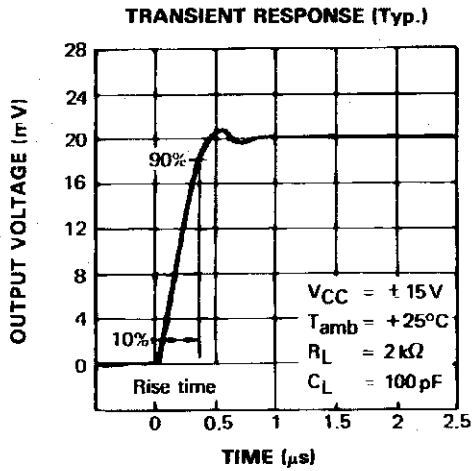

741-06.EPS

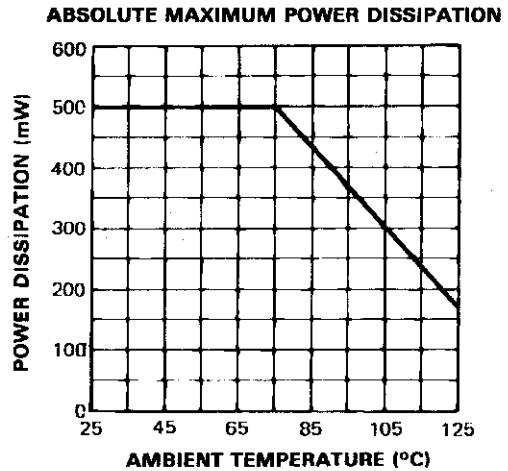

741-07.EPS

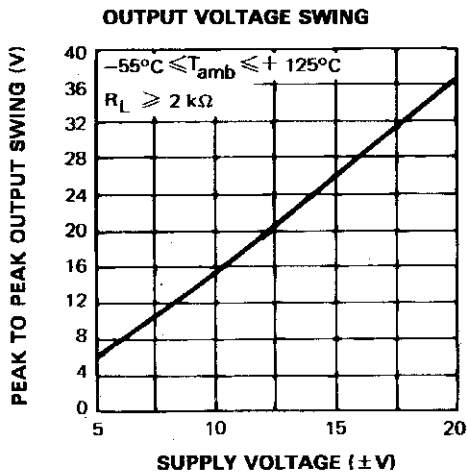

741-08.EPS

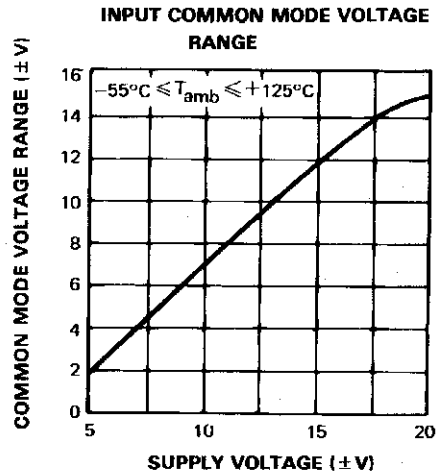

741-09.EPS

POWER CONSUMPTION

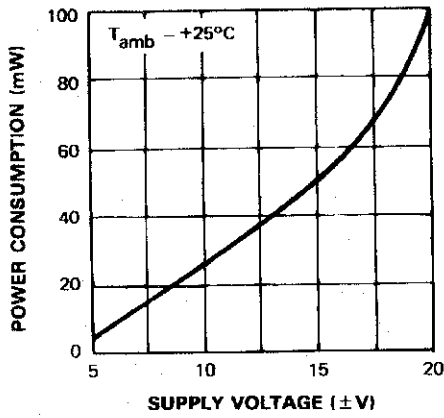

741-10.EPS

OUTPUT CURRENT vs AMBIENT TEMPERATURE

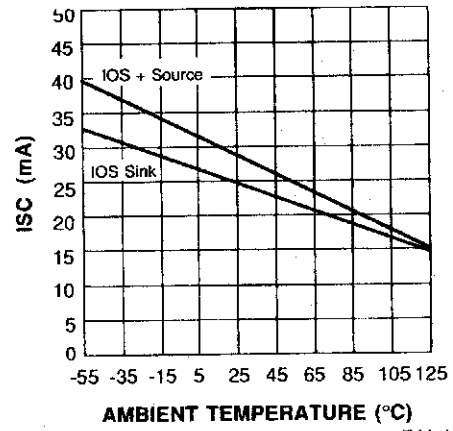

741-11.EPS

OUTPUT VOLTAGE SWING

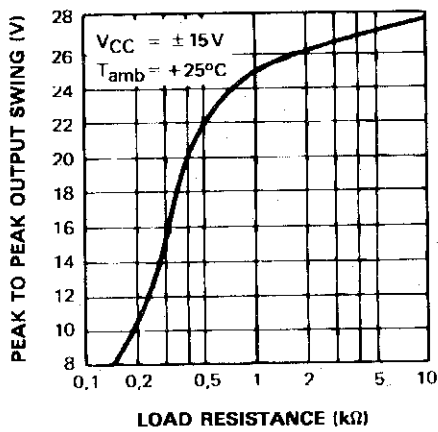

741-12.EPS

OUTPUT VOLTAGE SWING

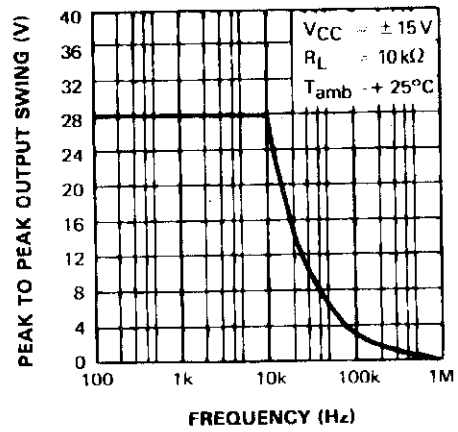

741-13.EPS

EQUIVALENT INPUT NOISE vs FREQUENCY
Rg = 100 Ω

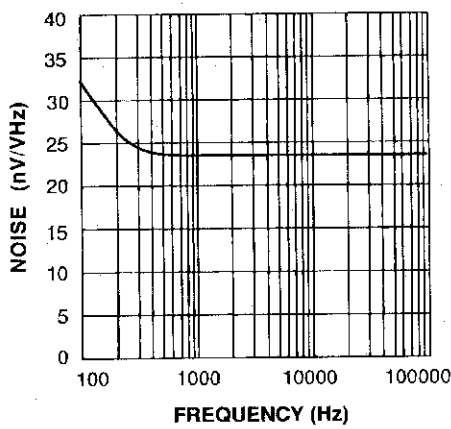

741-14.EPS

INPUT NOISE CURRENT

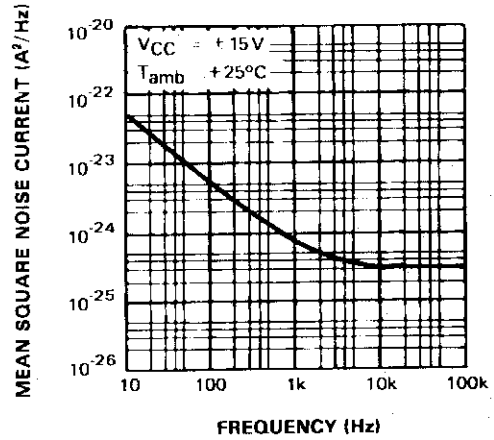

741-15.EPS

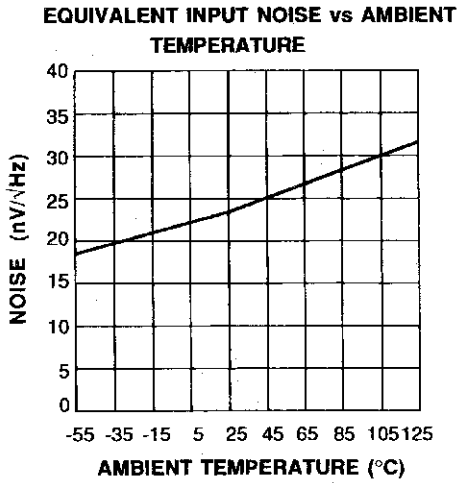

741-16.EPS

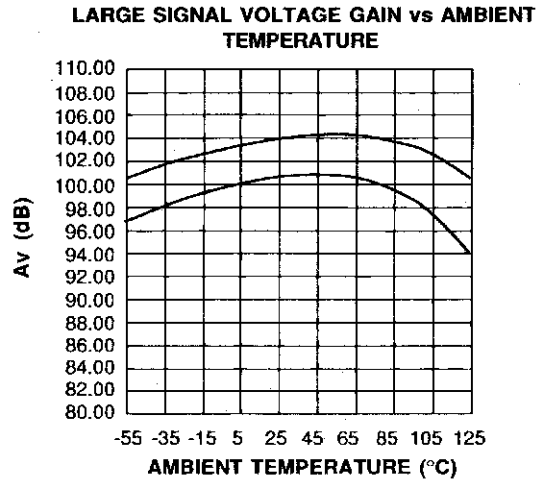

741-17.EPS

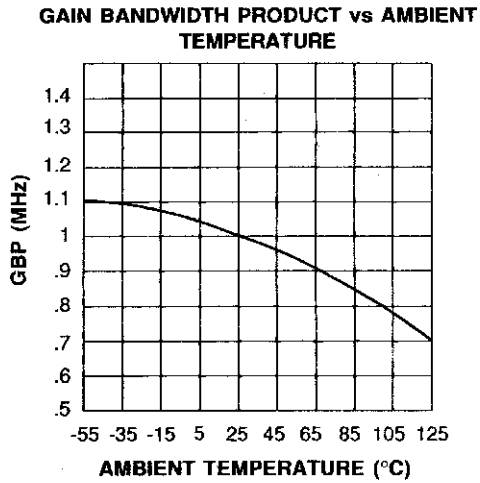

741-18.EPS

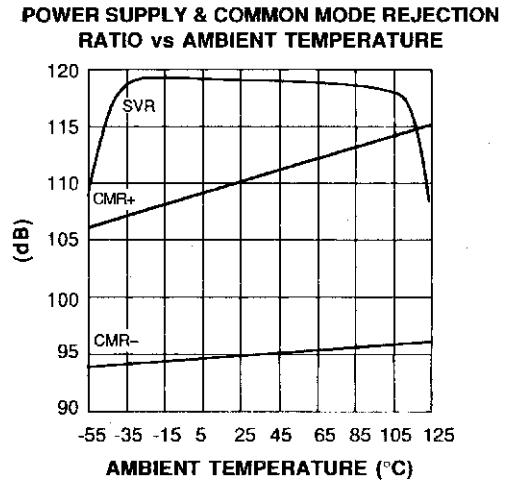

741-19.EPS

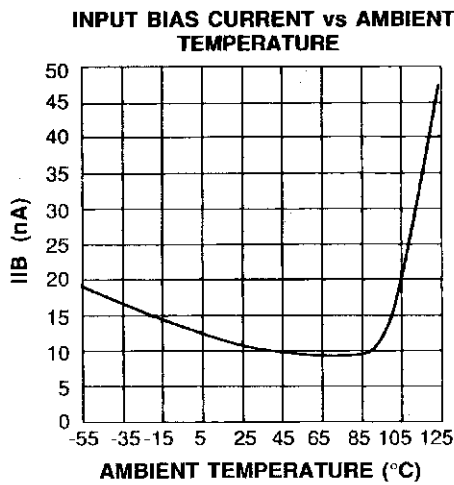

741-20.EPS

MEASUREMENT DIAGRAMS

OFFSET VOLTAGE NULL CIRCUIT

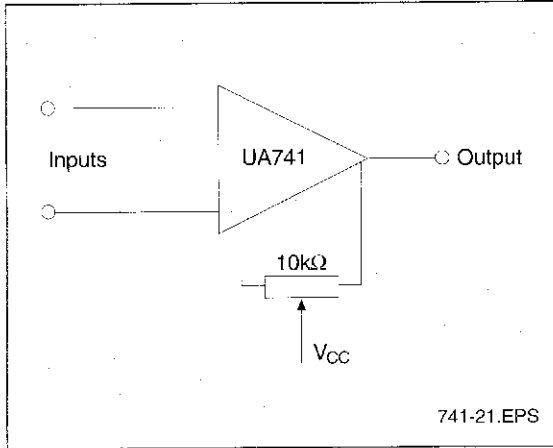

TRANSIENT RESPONSE TEST CIRCUIT

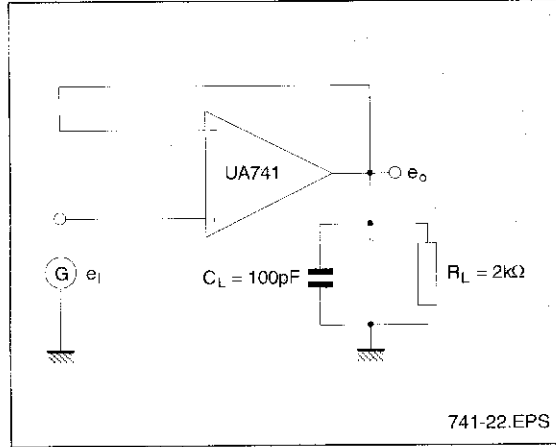

CURRENT TO VOLTAGE CONVERTER

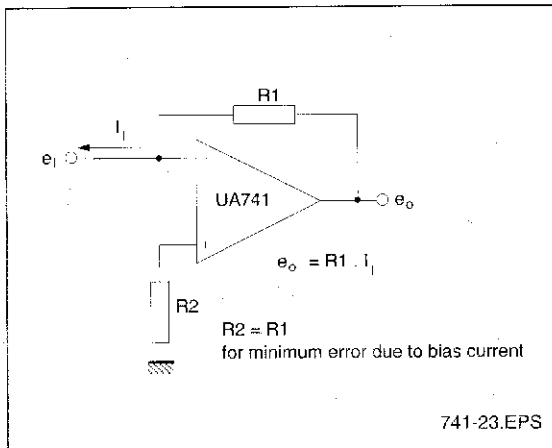

NEUTRALIZING INPUT CAPACITANCE TO OPTIMIZE RESPONSE TIME

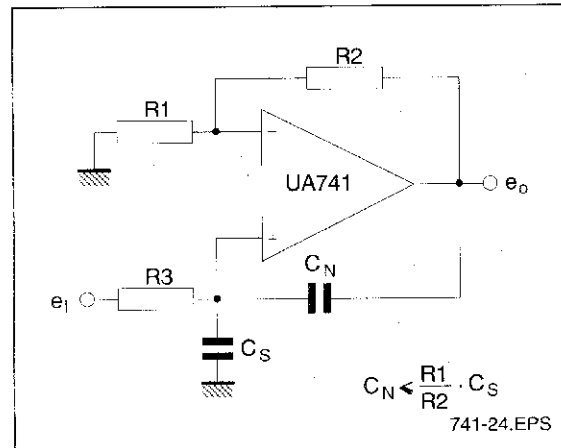

POSITIVE VOLTAGE REFERENCE

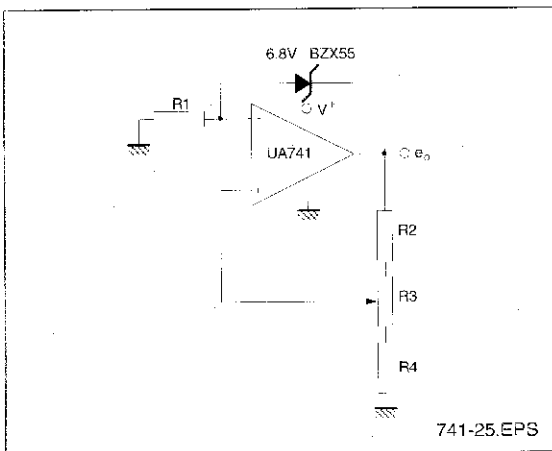

NEGATIVE VOLTAGE REFERENCE

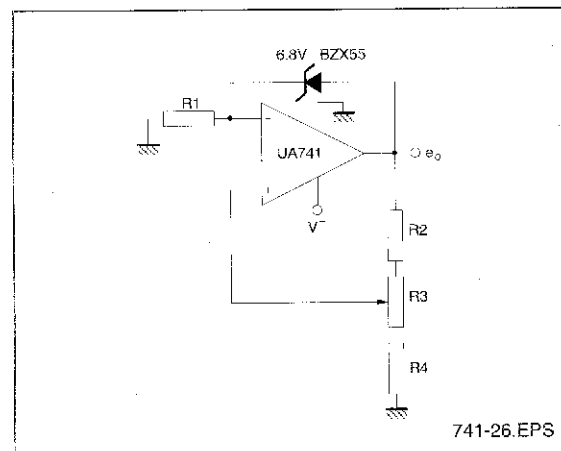

PACKAGE MECHANICAL DATA
8 PINS - PLASTIC DIP

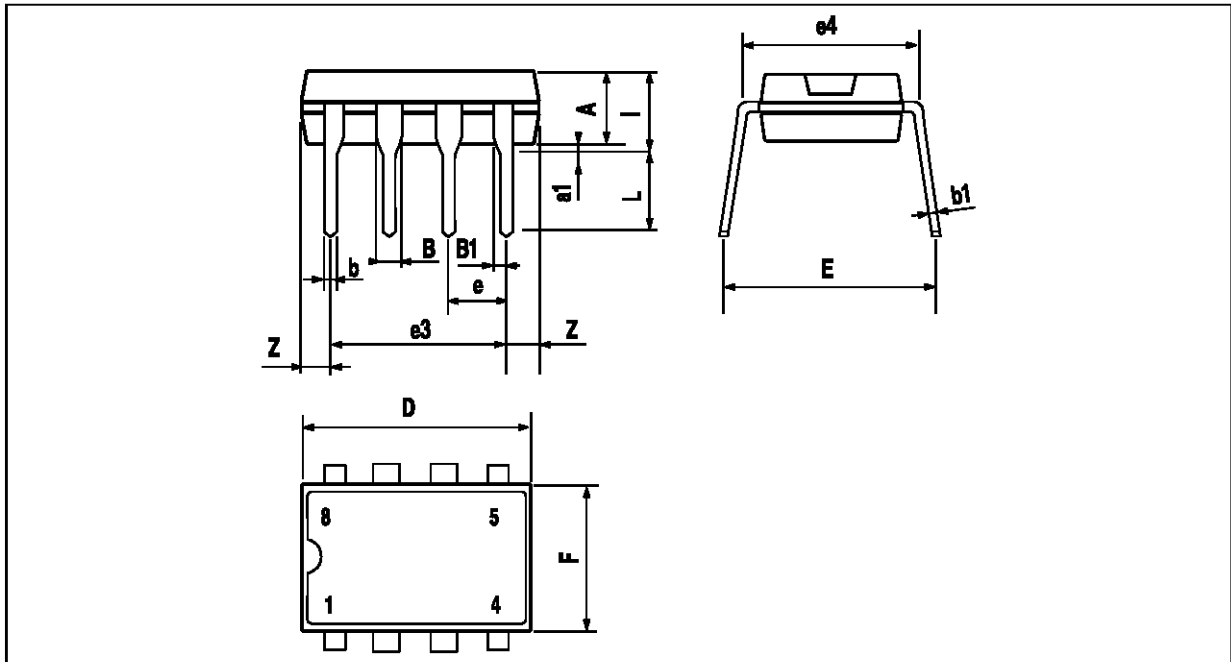

Dim.	Millimeters			Inches		
	Min.	Typ.	Max.	Min.	Typ.	Max.
A		3.32			0.131	
a1	0.51			0.020		
B	1.15		1.65	0.045		0.065
b	0.356		0.55	0.014		0.022
b1	0.204		0.304	0.008		0.012
D			10.92			0.430
E	7.95		9.75	0.313		0.384
e		2.54			0.100	
e3		7.62			0.300	
e4		7.62			0.300	
F			6.6			0.260
i			5.08			0.200
L	3.18		3.81	0.125		0.150
Z			1.52			0.060

PACKAGE MECHANICAL DATA
8 PINS - PLASTIC MICROPACKAGE (SO)

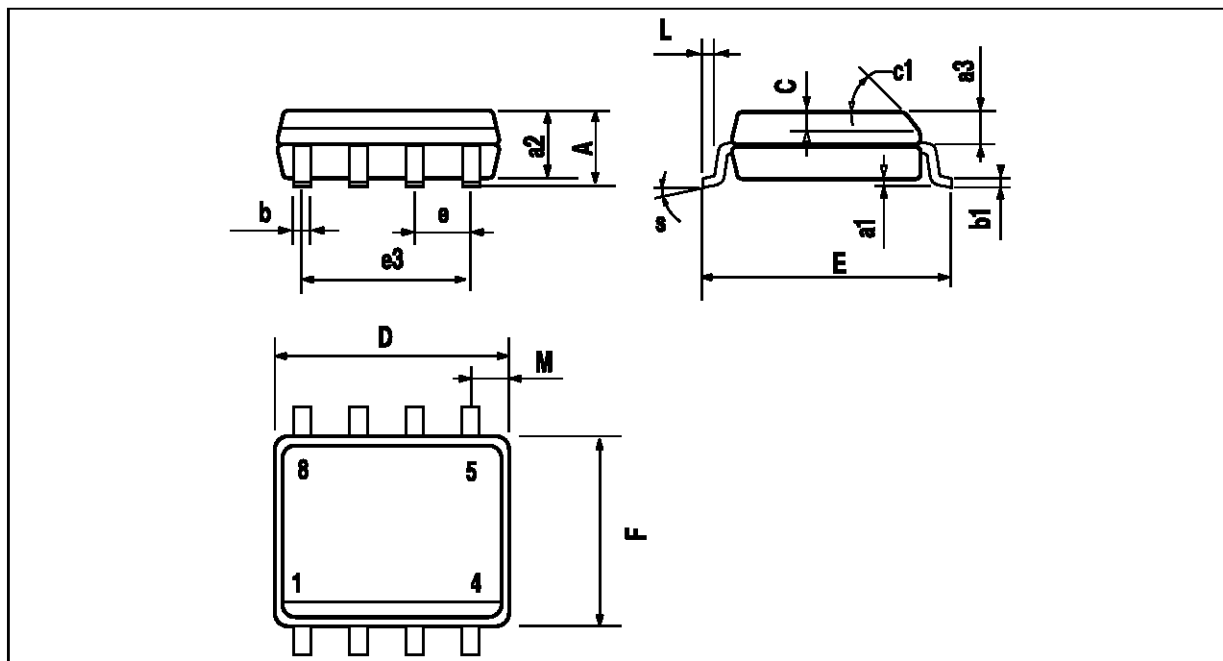

Dim.	Millimeters			Inches		
	Min.	Typ.	Max.	Min.	Typ.	Max.
A			1.75			0.069
a1	0.1		0.25	0.004		0.010
a2			1.65			0.065
a3	0.65		0.85	0.026		0.033
b	0.35		0.48	0.014		0.019
b1	0.19		0.25	0.007		0.010
C	0.25		0.5	0.010		0.020
c1	45° (typ.)					
D	4.8		5.0	0.189		0.197
E	5.8		6.2	0.228		0.244
e		1.27			0.050	
e3		3.81			0.150	
F	3.8		4.0	0.150		0.157
L	0.4		1.27	0.016		0.050
M			0.6			0.024
S	8° (max.)					

Information furnished is believed to be accurate and reliable. However, SGS-THOMSON Microelectronics assumes no responsibility for the consequences of use of such information nor for any infringement of patents or other rights of third parties which may result from its use. No license is granted by implication or otherwise under any patent or patent rights of SGS-THOMSON Microelectronics. Specifications mentioned in this publication are subject to change without notice. This publication supersedes and replaces all information previously supplied. SGS-THOMSON Microelectronics products are not authorized for use as critical components in life support devices or systems without express written approval of SGS-THOMSON Microelectronics.

© 1997 SGS-THOMSON Microelectronics – Printed in Italy – All Rights Reserved

SGS-THOMSON Microelectronics GROUP OF COMPANIES
 Australia - Brazil - Canada - China - France - Germany - Hong Kong - Italy - Japan - Korea - Malaysia - Malta - Morocco
 The Netherlands - Singapore - Spain - Sweden - Switzerland - Taiwan - Thailand - United Kingdom - U.S.A.

ORDER CODE :