

MULTIFUNCTION VOLTAGE REGULATOR FOR CAR RADIO

- 3 PROGRAMMABLE OUTPUTS:
 - ◆ 3 TO 11V (500mA);
 - ◆ 3 TO 11V (500mA);
 - ◆ 3 TO 7V (500mA) STANDBY
- OUT1 AND OUT2 WITH INDEPENDENT ENABLE CONTROL FOR STAND-BY MODE
- 0.4A HIGH SIDE DRIVER
- LOAD DUMP PROTECTION
- THERMAL SHUTDOWN

DESCRIPTION

The L4943 contains a triple voltage regulator and a high side driver.

In stand-by the output is active as long as possible even when in thermal shutdown or under any other fault conditions.

The STCAP pin allows the use of a reserve supply capacitor that will hold enough energy for the

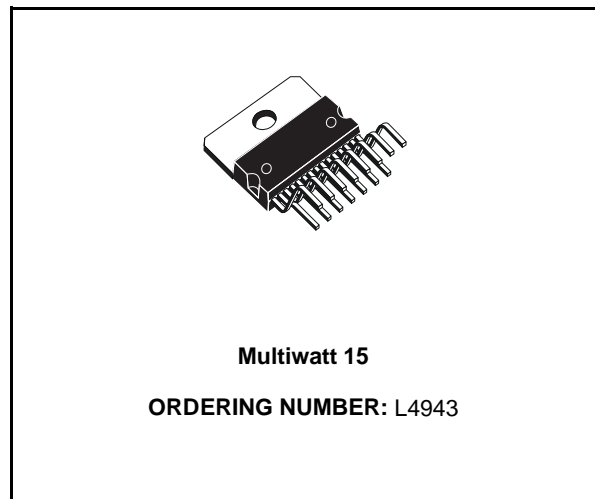

5V Stand-by line to allow the μ P to store data.

BLOCK DIAGRAM

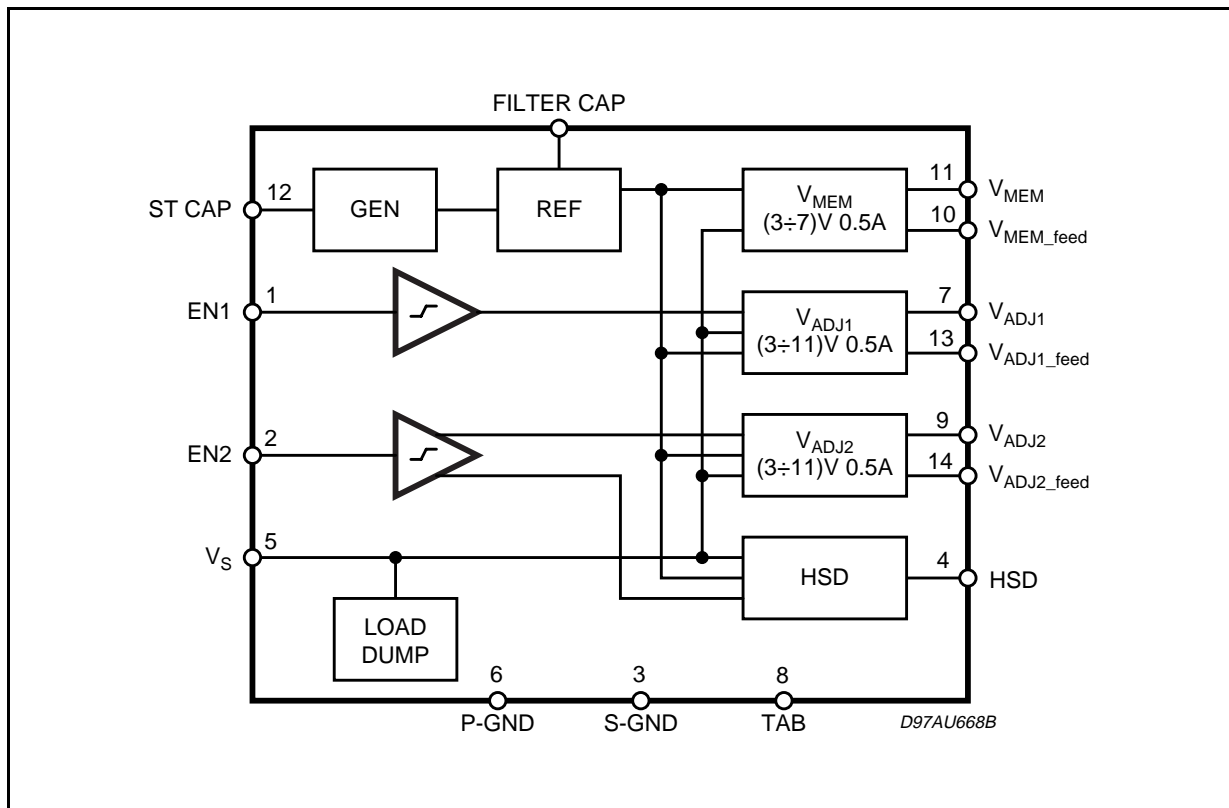

ABSOLUTE MAXIMUM RATINGS

Symbol	Parameter	Value	Unit
V_S	DC Operating Supply Voltage	-0.6 to 30	V
	Transient Supply Overvoltage (50ms)	50	V
I_O	Voltage Regulator Output Current	Internally limited	
V_{in}	Input Voltage (EN1, EN2)	0 to 6	V
RESR	Output Capacitor Series Eq. Resistance	0.2 to 10	Ω
P_{tot}	Power Dissipation ($T_{case} = 85^\circ\text{C}$)	33	W
T_{op}	Operating Temperature Range	-40 to 85	$^\circ\text{C}$
T_{stg}	Storage Temperature Ranges	-55 to 150	$^\circ\text{C}$

PIN CONNECTION (t.b.d.)

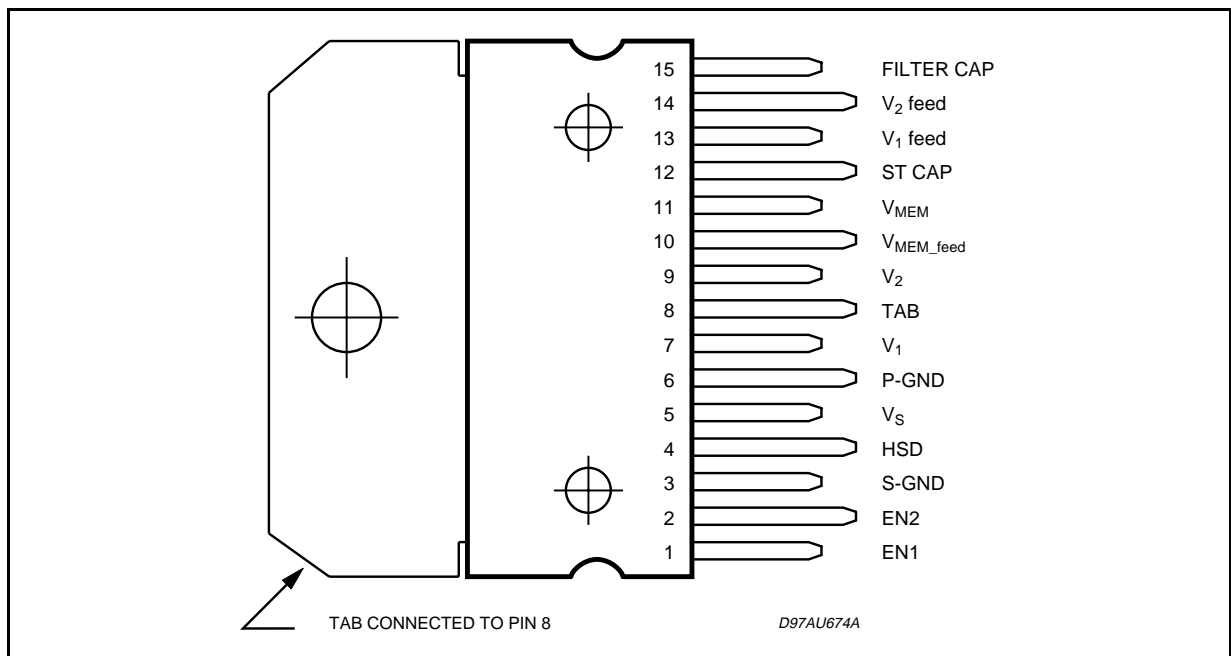

THERMAL DATA

Symbol	Parameter	Value	Unit
$R_{Th\ j-case}$	Thermal Resistance Junction to Case	2	$^\circ\text{C}/\text{W}$

ELECTRICAL CHARACTERISTICS (Referred to Test & Application Circuit; $V_S = 14.4V$; $T_{amb} = 25^\circ C$; unless otherwise specified).

Symbol	Parameter	Test Condition	Min.	Typ.	Max.	Unit
5V STAND-BY						
$V_{out\ Mem}$	Output Voltage	no load; $1+R1/R2 = 2.4$	2.85	3	3.15	V
		no load; $1+R1/R2 = 4$	4.75	5	5.25	V
		no load; $1+R1/R2 = 5.6$	6.65	7	7.35	V
ΔV_{line}	Line Regulation	no load; $11 < V_S < 18V$		5	50	mV
ΔV_{load}	Load Regulation	$5mA < I_O < 500mA$		8	80	mV
$V_{dropout}$	Dropout Voltage	$I_O = 200mA, V_O = 5V$		0.36	0.5	V
		$I_O = 500mA, V_O = 5V$		0.9	1.25	V
I_{lim}	Current Limit	Out short to GND	550	800	1000	mA
I_{qst-by}	Quiescent Current	$I_O = 100\mu A; EN1 = EN2 = 0$		0.35	0.5	mA
		$I_O = 500mA; EN1 = EN2 = 5V$		10	25	mA
ADJUSTABLE REG1 SWITCHED						
V_{outadj}	Output Voltage	no load; $1+R3/R4 = 2.4$	2.85	3	3.15	V
		no load; $1+R3/R4 = 4$	4.75	5	5.25	V
		no load; $1+R3/R4 = 8.8$	10.45	11	11.55	V
ΔV_{line}	Line Regulation	no load		0.7	7	mV/V
ΔV_{load}	Load Regulation	$5mA < I_O < 500mA$		8	80	mV
$V_{dropout}$	Dropout Voltage	$I_O = 200mA, V_O = 5V$		0.45	0.6	V
		$I_O = 500mA, V_O = 5V$		1.1	1.5	V
		$I_O = 200mA, V_O = 11V$		0.4	0.55	V
		$I_O = 500mA, V_O = 11V$		1	1.4	V
I_{lim}	Current Limit	Out short to GND	550	800	1000	mA
I_{q2}	Quiescent Current	$I_O = 500mA$		10	25	mA
SVR	Supply Voltage Rejection	$f = 0.1$ to $10kHz, V_O = 5V$	45	55		dB
EN1 on	EN ADJ1 ON		2			V
EN1 off	EN ADJ1 OFF				1	V
ADJUSTABLE REG2 SWITCHED						
V_{outadj}	Output Voltage	no load; $1+R3/R4 = 2.4$	2.85	3	3.15	V
		no load; $1+R5/R6 = 4$	4.75	5	5.25	V
		no load; $1+R3/R4 = 8.8$	10.45	11	11.55	V
ΔV_{line}	Line Regulation	no load		0.7	7	mV/V
ΔV_{load}	Load Regulation	$5mA < I_O < 500mA$		12	80	mV
$V_{dropout}$	Dropout Voltage	$I_O = 200mA, V_O = 5V$		0.45	0.6	V
		$I_O = 500mA, V_O = 5V$		1.1	1.5	V
		$I_O = 200mA, V_O = 11V$		0.4	0.55	V
		$I_O = 500mA, V_O = 11V$		1	1.4	V
I_{lim}	Current Limit	Out short to GND	550	800	1100	mA
I_{q3}	Quiescent Current	$I_O = 500mA$		10	25	mA
SVR	Supply Voltage Rejection	$f = 0.1$ to $10kHz, V_O = 5V$	45	55		dB
EN2H on2	EN ADJ2 ON		1.3			V
EN2H off2	EN ADJ2 OFF				0.5	V
400mA HSD SWITCHED						
$V_{dropout}$	Dropout Voltage	$I_O = 400mA, 9V < V_S < 16V$		0.2	0.6	V
I_{lim}	Current Limit		0.45	0.65	0.8	A
I_{qhsd}	Quiescent Current	$I_O = 400mA$		10	25	mA
EN2 on H	EN HSD ON		2.5			V
EN2 off H	EN HSD OFF				1.7	V
EN2 Gap	EN HSD ON minus EN ADJ2 ON			1		V

Figure 1. Application circuit.

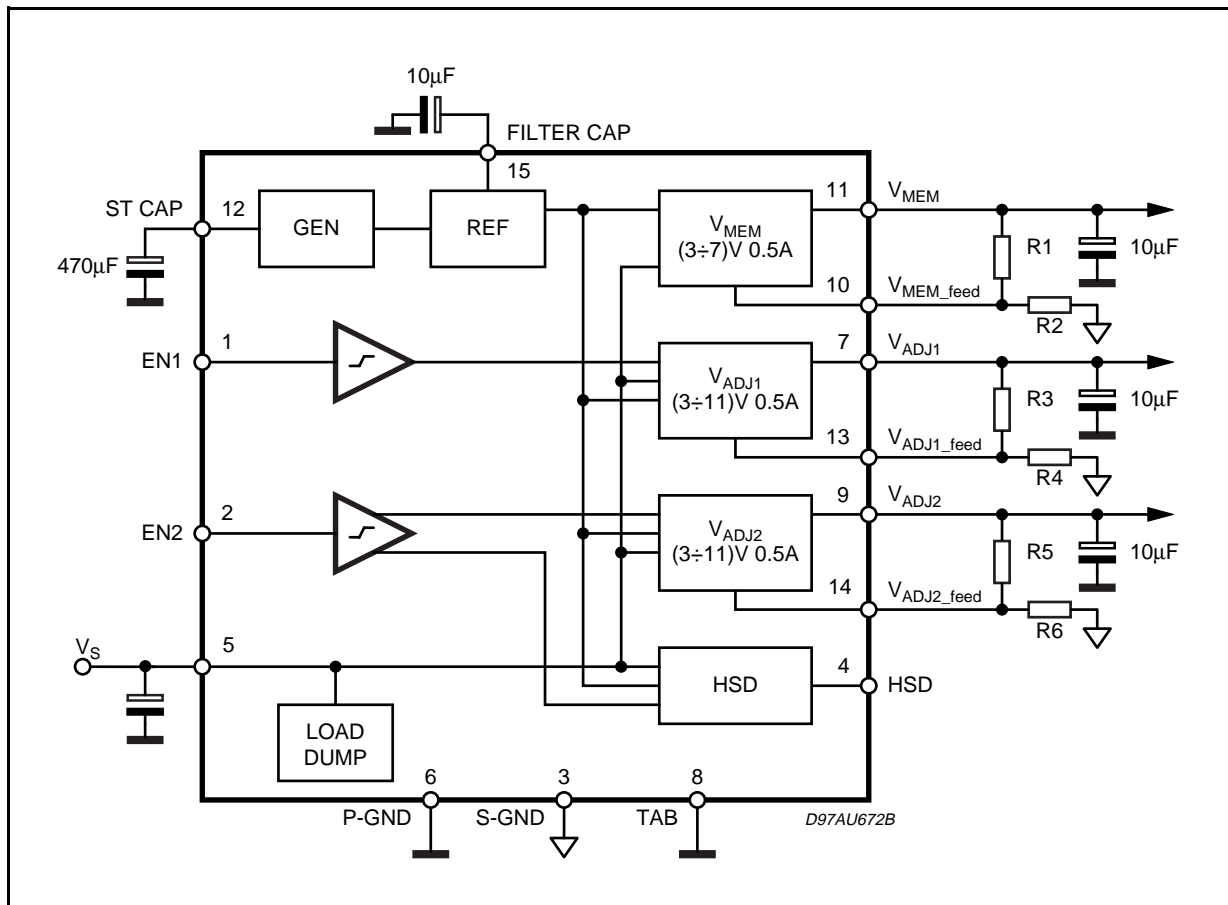

DIM.	mm			inch		
	MIN.	TYP.	MAX.	MIN.	TYP.	MAX.
A			5			0.197
B			2.65			0.104
C			1.6			0.063
D		1			0.039	
E	0.49		0.55	0.019		0.022
F	0.66		0.75	0.026		0.030
G	1.02	1.27	1.52	0.040	0.050	0.060
G1	17.53	17.78	18.03	0.690	0.700	0.710
H1	19.6			0.772		
H2			20.2			0.795
L	21.9	22.2	22.5	0.862	0.874	0.886
L1	21.7	22.1	22.5	0.854	0.870	0.886
L2	17.65		18.1	0.695		0.713
L3	17.25	17.5	17.75	0.679	0.689	0.699
L4	10.3	10.7	10.9	0.406	0.421	0.429
L7	2.65		2.9	0.104		0.114
M	4.25	4.55	4.85	0.167	0.179	0.191
M1	4.63	5.08	5.53	0.182	0.200	0.218
S	1.9		2.6	0.075		0.102
S1	1.9		2.6	0.075		0.102
Dia1	3.65		3.85	0.144		0.152

OUTLINE AND MECHANICAL DATA

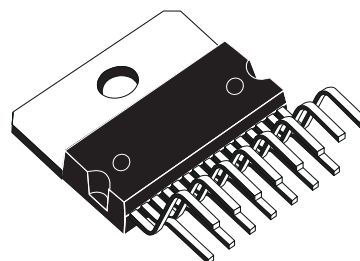

Multiwatt15 V

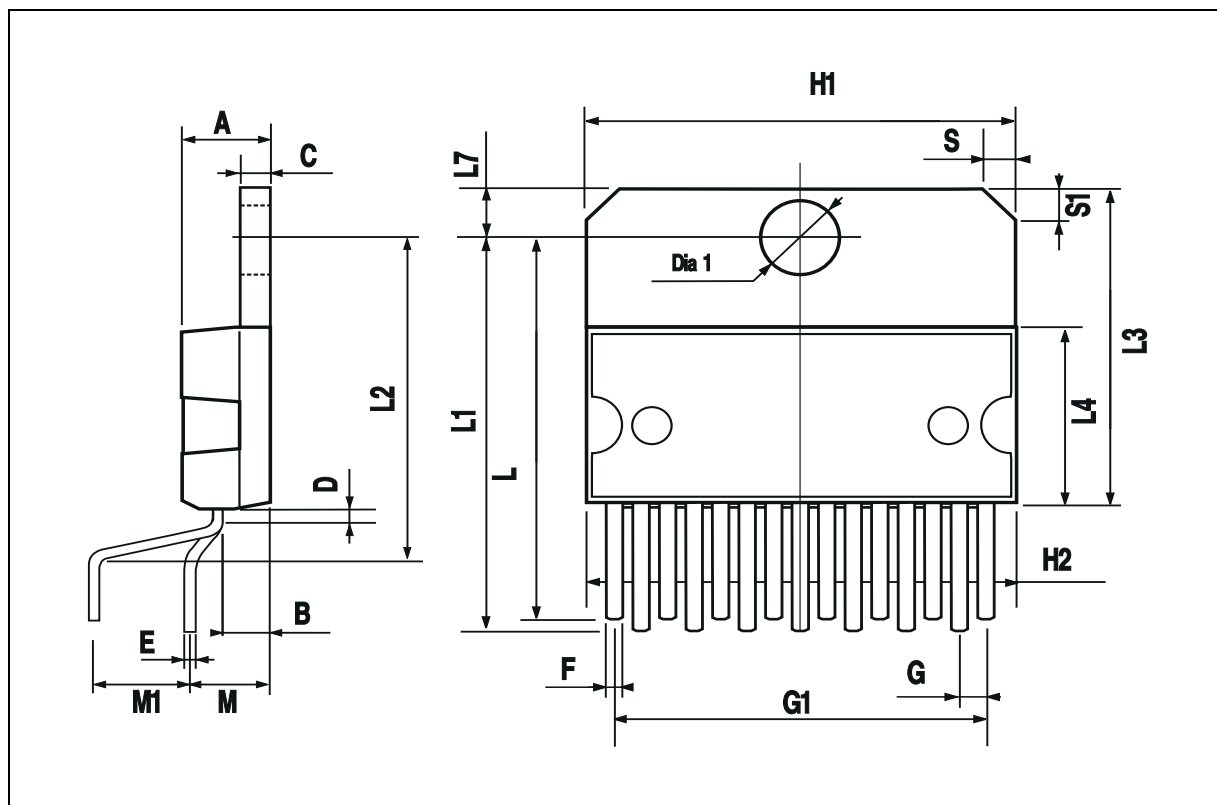

Information furnished is believed to be accurate and reliable. However, STMicroelectronics assumes no responsibility for the consequences of use of such information nor for any infringement of patents or other rights of third parties which may result from its use. No license is granted by implication or otherwise under any patent or patent rights of STMicroelectronics. Specification mentioned in this publication are subject to change without notice. This publication supersedes and replaces all information previously supplied. STMicroelectronics products are not authorized for use as critical components in life support devices or systems without express written approval of STMicroelectronics.

The ST logo is a registered trademark of STMicroelectronics

© 2001 STMicroelectronics – Printed in Italy – All Rights Reserved

STMicroelectronics GROUP OF COMPANIES

Australia - Brazil - China - Finland - France - Germany - Hong Kong - India - Italy - Japan - Malaysia - Malta - Morocco -
Singapore - Spain - Sweden - Switzerland - United Kingdom - U.S.A.

<http://www.st.com>