

POSITIVE VOLTAGE REGULATORS

- OUTPUT CURRENT UP TO 100 mA
- OUTPUT VOLTAGES OF 3.3; 5; 6; 8; 9; 10; 12; 15; 18; 20; 24V
- THERMAL OVERLOAD PROTECTION
- SHORT CIRCUIT PROTECTION
- NO EXTERNAL COMPONENTS ARE REQUIRED
- AVAILABLE IN EITHER $\pm 5\%$ (AC) OR $\pm 10\%$ (C) SELECTION

DESCRIPTION

The L78L00 series of three-terminal positive regulators employ internal current limiting and thermal shutdown, making them essentially indestructible. If adequate heat-sink is provided, they can deliver up to 100 mA output current. They are intended as fixed voltage regulators in a wide range of applications including local or on-card regulation for elimination of noise and distribution problems associated with single-point regulation. In addition, they can be used with power pass elements to make high-current voltage regulators. The L78L00 series used as Zener diode/resistor combination replacement, offers an effective output impedance improvement of typically two

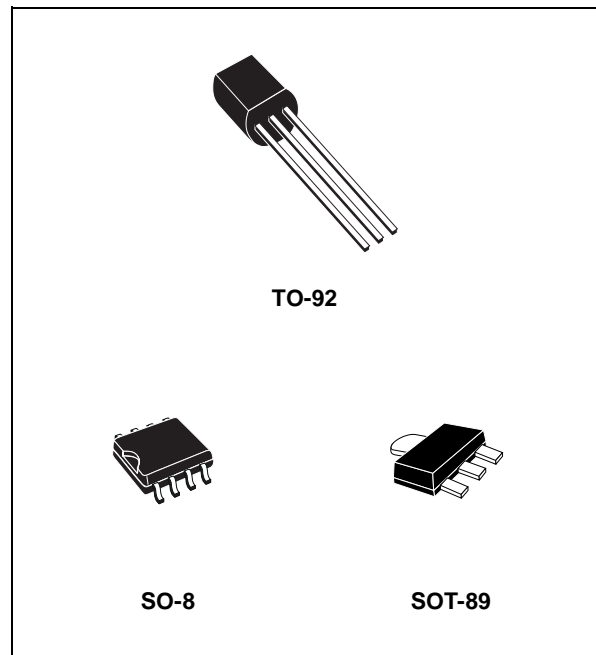

orders of magnitude, along with lower quiescent current and lower noise.

SCHEMATIC DIAGRAM

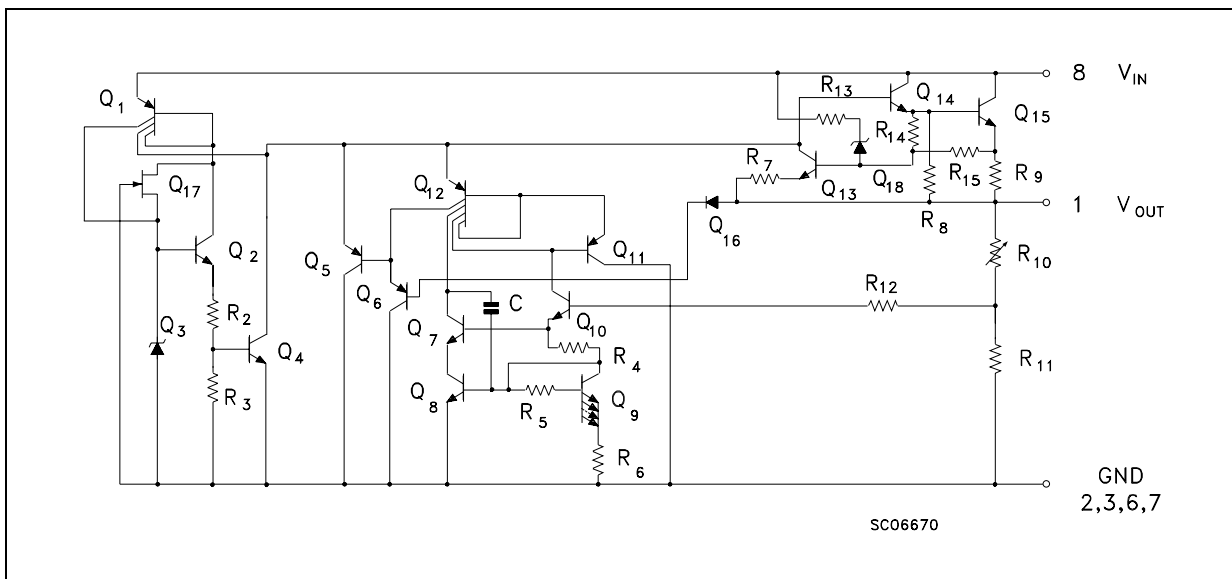

L78L00 SERIES

ABSOLUTE MAXIMUM RATINGS

Symbol	Parameter ²		Value	Unit
V_I	DC Input Voltage	$V_O = 3.3$ to 9 V	30	V
		$V_O = 12$ to 15 V	35	
		$V_O = 18$ to 24 V	40	
I_O	Output Current		100	mA
P_{tot}	Power Dissipation		Internally Limited (*)	
T_{stg}	Storage Temperature Range		-40 to 150	°C
T_{op}	Operating Junction Temperature Range	for L78L00C, L78L00AC	0 to 125	°C
		for L78L00AB	-40 to 125	

(*) Our SO-8 package used for Voltage Regulators is modified internally to have pins 2, 3, 6 and 7 electrically communed to the die attach flag. This particular frame decreases the total thermal resistance of the package and increases its ability to dissipate power when an appropriate area of copper on the printed circuit board is available for heat-sinking. The external dimensions are the same as for the standard SO-8.

THERMAL DATA

Symbol	Parameter		SO-8	TO-92	SOT-89	Unit
$R_{thj-case}$	Thermal Resistance Junction-case	Max	20		15	°C/W
$R_{thj-amb}$	Thermal Resistance Junction-ambient	Max	55 (*)	200		°C/W

(*) Considering 6 cm² of copper Board heat-sink

TEST CIRCUITS

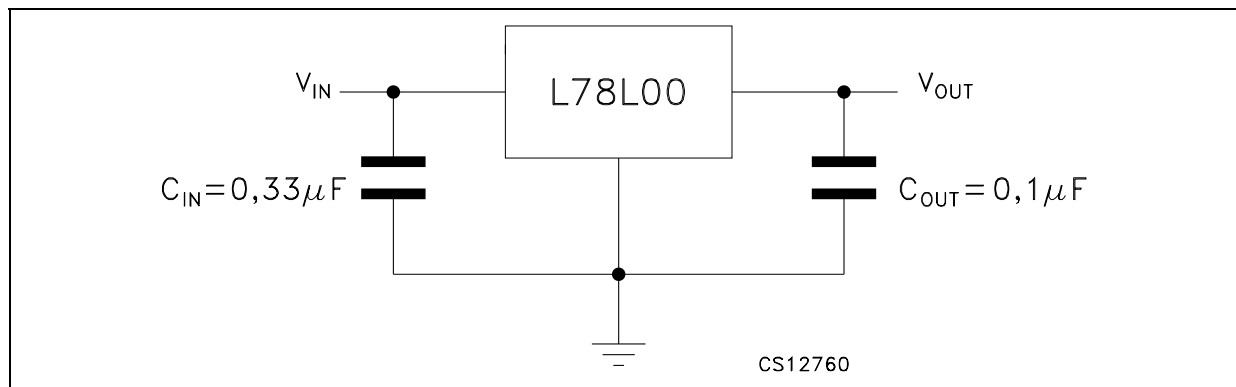

CONNECTION DIAGRAM (top view)

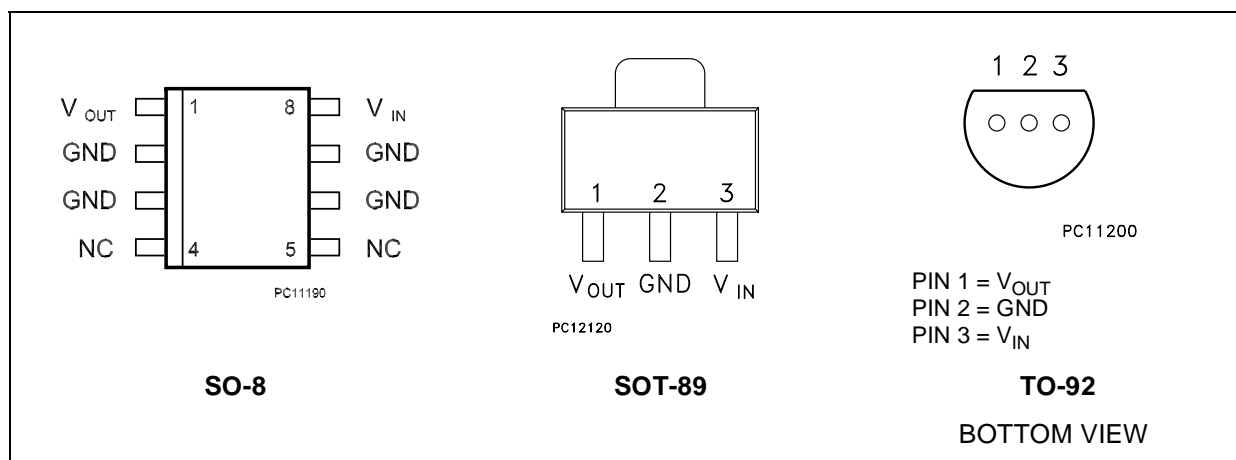

ORDERING CODES

TYPE	SO-8 (TUBE)*	TO-92 (TUBE)**	SOT-89 (T&R)	OUTPUT VOLTAGE
L78L33C	L78L33CD	L78L33CZ		3.3 V
L78L33AC	L78L33ACD	L78L33ACZ	L78L33ACUTR	3.3 V
L78L33AB	L78L33ABD	L78L33ABZ	L78L33ABUTR	3.3 V
L78L05C	L78L05CD	L78L05CZ		5 V
L78L05AC	L78L05ACD	L78L05ACZ	L78L05ACUTR	5 V
L78L05AB	L78L05ABD	L78L05ABZ	L78L05ABUTR	5 V
L78L06C	L78L06CD	L78L06CZ		6 V
L78L06AC	L78L06ACD	L78L06ACZ	L78L06ACUTR	6 V
L78L06AB	L78L06ABD	L78L06ABZ	L78L06ABUTR	6 V
L78L08C	L78L08CD	L78L08CZ		8 V
L78L08AC	L78L08ACD	L78L08ACZ	L78L08ACUTR	8 V
L78L08AB	L78L08ABD	L78L08ABZ	L78L08ABUTR	8 V
L78L09C	L78L09CD	L78L09CZ		9 V
L78L09AC	L78L09ACD	L78L09ACZ	L78L09ACUTR	9 V
L78L09AB	L78L09ABD	L78L09ABZ	L78L09ABUTR	9 V
L78L10C	L78L10CD	L78L10CZ		10 V
L78L10AC	L78L10ACD	L78L10ACZ	L78L10ACUTR	10 V
L78L10AB	L78L10ABD	L78L10ABZ	L78L10ABUTR	10 V
L78L12C	L78L12CD	L78L12CZ		12 V
L78L12AC	L78L12ACD	L78L12ACZ	L78L12ACUTR	12 V
L78L12AB	L78L12ABD	L78L12ABZ	L78L12ABUTR	12 V
L78L15C	L78L15CD	L78L15CZ		15 V
L78L15AC	L78L15ACD	L78L15ACZ	L78L15ACUTR	15 V
L78L15AB	L78L15ABD	L78L15ABZ	L78L15ABUTR	15 V
L78L18C	L78L18CD	L78L18CZ		18 V
L78L18AC	L78L18ACD	L78L18ACZ	L78L18ACUTR	18 V
L78L18AB	L78L18ABD	L78L18ABZ	L78L18ABUTR	18 V
L78L20C	L78L20CD	L78L20CZ		20 V
L78L20AC	L78L20ACD	L78L20ACZ	L78L20ACUTR	20 V
L78L20AB	L78L20ABD	L78L20ABZ	L78L20ABUTR	20 V
L78L24C	L78L24CD	L78L24CZ		24 V
L78L24AC	L78L24ACD	L78L24ACZ	L78L24ACUTR	24 V
L78L24AB	L78L24ABD	L78L24ABZ	L78L24ABUTR	24 V

(*) Available in Tape & Reel with the suffix "13TR".

(**) Available in Ammopak with the suffix "-AP" or in Tape & Reel with the suffix "TR".

L78L00 SERIES

ELECTRICAL CHARACTERISTICS OF L78L33C (refer to the test circuits, $T_J = 0$ to 125°C , $V_I = 8.3\text{V}$, $I_O = 40$ mA, $C_I = 0.33$ μF , $C_O = 0.1$ μF unless otherwise specified)

Symbol	Parameter	Test Conditions	Min.	Typ.	Max.	Unit
V_O	Output Voltage	$T_J = 25^\circ\text{C}$	3.036	3.3	3.564	V
V_O	Output Voltage	$I_O = 1$ to 40 mA $V_I = 5.3$ to 20 V	2.97		3.63	V
		$I_O = 1$ to 70 mA $V_I = 8.3$ V	2.97		3.63	
ΔV_O	Line Regulation	$V_I = 5.3$ to 20 V $T_J = 25^\circ\text{C}$			150	mV
		$V_I = 6.3$ to 20 V $T_J = 25^\circ\text{C}$			100	
ΔV_O	Load Regulation	$I_O = 1$ to 100 mA $T_J = 25^\circ\text{C}$			60	mV
		$I_O = 1$ to 40 mA $T_J = 25^\circ\text{C}$			30	
I_d	Quiescent Current	$T_J = 25^\circ\text{C}$			6	mA
		$T_J = 125^\circ\text{C}$			5.5	mA
ΔI_d	Quiescent Current Change	$I_O = 1$ to 40 mA			0.2	mA
		$V_I = 6.3$ to 20 V			1.5	
eN	Output Noise Voltage	B = 10Hz to 100KHz $T_J = 25^\circ\text{C}$		40		μV
SVR	Supply Voltage Rejection	$V_I = 6.3$ to 16.3 V $f = 120\text{Hz}$ $I_O = 40$ mA $T_J = 25^\circ\text{C}$	41	49		dB
V_d	Dropout Voltage			1.7		V

ELECTRICAL CHARACTERISTICS OF L78L05C (refer to the test circuits, $T_J = 0$ to 125°C , $V_I = 10\text{V}$, $I_O = 40$ mA, $C_I = 0.33$ μF , $C_O = 0.1$ μF unless otherwise specified).

Symbol	Parameter	Test Conditions	Min.	Typ.	Max.	Unit
V_O	Output Voltage	$T_J = 25^\circ\text{C}$	4.6	5	5.4	V
V_O	Output Voltage	$I_O = 1$ to 40 mA $V_I = 7$ to 20 V	4.5		5.5	V
		$I_O = 1$ to 70 mA $V_I = 10$ V	4.5		5.5	
ΔV_O	Line Regulation	$V_I = 8.5$ to 20 V $T_J = 25^\circ\text{C}$			200	mV
		$V_I = 9$ to 20 V $T_J = 25^\circ\text{C}$			150	
ΔV_O	Load Regulation	$I_O = 1$ to 100 mA $T_J = 25^\circ\text{C}$			60	mV
		$I_O = 1$ to 40 mA $T_J = 25^\circ\text{C}$			30	
I_d	Quiescent Current	$T_J = 25^\circ\text{C}$			6	mA
		$T_J = 125^\circ\text{C}$			5.5	mA
ΔI_d	Quiescent Current Change	$I_O = 1$ to 40 mA			0.2	mA
		$V_I = 8$ to 20 V			1.5	
eN	Output Noise Voltage	B = 10Hz to 100KHz $T_J = 25^\circ\text{C}$		40		μV
SVR	Supply Voltage Rejection	$V_I = 9$ to 20 V $f = 120\text{Hz}$ $I_O = 40$ mA $T_J = 25^\circ\text{C}$	40	49		dB
V_d	Dropout Voltage			1.7		V

ELECTRICAL CHARACTERISTICS OF L78L06C (refer to the test circuits, $T_J = 0$ to 125°C , $V_I = 12\text{V}$, $I_O = 40$ mA, $C_I = 0.33$ μF , $C_O = 0.1$ μF unless otherwise specified).

Symbol	Parameter	Test Conditions	Min.	Typ.	Max.	Unit
V_O	Output Voltage	$T_J = 25^\circ\text{C}$	5.52	6	6.48	V
V_O	Output Voltage	$I_O = 1$ to 40 mA $V_I = 8.5$ to 20 V	5.4		6.6	V
		$I_O = 1$ to 70 mA $V_I = 12$ V	5.4		6.6	
ΔV_O	Line Regulation	$V_I = 8.5$ to 20 V $T_J = 25^\circ\text{C}$			200	mV
		$V_I = 9$ to 20 V $T_J = 25^\circ\text{C}$			150	
ΔV_O	Load Regulation	$I_O = 1$ to 100 mA $T_J = 25^\circ\text{C}$			60	mV
		$I_O = 1$ to 40 mA $T_J = 25^\circ\text{C}$			30	
I_d	Quiescent Current	$T_J = 25^\circ\text{C}$			6	mA
		$T_J = 125^\circ\text{C}$			5.5	mA
ΔI_d	Quiescent Current Change	$I_O = 1$ to 40 mA			0.2	mA
		$V_I = 8$ to 20 V			1.5	
eN	Output Noise Voltage	$B = 10\text{Hz}$ to 100KHz $T_J = 25^\circ\text{C}$		50		μV
SVR	Supply Voltage Rejection	$V_I = 9$ to 20 V $f = 120\text{Hz}$ $I_O = 40$ mA $T_J = 25^\circ\text{C}$	38	46		dB
V_d	Dropout Voltage			1.7		V

ELECTRICAL CHARACTERISTICS OF L78L08C (refer to the test circuits, $T_J = 0$ to 125°C , $V_I = 14\text{V}$, $I_O = 40$ mA, $C_I = 0.33$ μF , $C_O = 0.1$ μF unless otherwise specified).

Symbol	Parameter	Test Conditions	Min.	Typ.	Max.	Unit
V_O	Output Voltage	$T_J = 25^\circ\text{C}$	7.36	8	8.64	V
V_O	Output Voltage	$I_O = 1$ to 40 mA $V_I = 10.5$ to 23 V	7.2		8.8	V
		$I_O = 1$ to 70 mA $V_I = 14$ V	7.2		8.8	
ΔV_O	Line Regulation	$V_I = 10.5$ to 23 V $T_J = 25^\circ\text{C}$			200	mV
		$V_I = 11$ to 23 V $T_J = 25^\circ\text{C}$			150	
ΔV_O	Load Regulation	$I_O = 1$ to 100 mA $T_J = 25^\circ\text{C}$			80	mV
		$I_O = 1$ to 40 mA $T_J = 25^\circ\text{C}$			40	
I_d	Quiescent Current	$T_J = 25^\circ\text{C}$			6	mA
		$T_J = 125^\circ\text{C}$			5.5	mA
ΔI_d	Quiescent Current Change	$I_O = 1$ to 40 mA			0.2	mA
		$V_I = 11$ to 23 V			1.5	
eN	Output Noise Voltage	$B = 10\text{Hz}$ to 100KHz $T_J = 25^\circ\text{C}$		60		μV
SVR	Supply Voltage Rejection	$V_I = 12$ to 23 V $f = 120\text{Hz}$ $I_O = 40$ mA $T_J = 25^\circ\text{C}$	36	45		dB
V_d	Dropout Voltage			1.7		V

L78L00 SERIES

ELECTRICAL CHARACTERISTICS OF L78L09C (refer to the test circuits, $T_J = 0$ to 125°C , $V_I = 15\text{V}$, $I_O = 40\text{ mA}$, $C_I = 0.33\ \mu\text{F}$, $C_O = 0.1\ \mu\text{F}$ unless otherwise specified).

Symbol	Parameter	Test Conditions	Min.	Typ.	Max.	Unit
V_O	Output Voltage	$T_J = 25^\circ\text{C}$	8.28	9	9.72	V
V_O	Output Voltage	$I_O = 1$ to 40 mA $V_I = 11.5$ to 23 V	8.1		9.9	V
		$I_O = 1$ to 70 mA $V_I = 15\text{ V}$	8.1		9.9	
ΔV_O	Line Regulation	$V_I = 11.5$ to 23 V $T_J = 25^\circ\text{C}$			250	mV
		$V_I = 12$ to 23 V $T_J = 25^\circ\text{C}$			200	
ΔV_O	Load Regulation	$I_O = 1$ to 100 mA $T_J = 25^\circ\text{C}$			80	mV
		$I_O = 1$ to 40 mA $T_J = 25^\circ\text{C}$			40	
I_d	Quiescent Current	$T_J = 25^\circ\text{C}$			6	mA
		$T_J = 125^\circ\text{C}$			5.5	mA
ΔI_d	Quiescent Current Change	$I_O = 1$ to 40 mA			0.2	mA
		$V_I = 12$ to 23 V			1.5	
eN	Output Noise Voltage	$B = 10\text{Hz}$ to 100KHz $T_J = 25^\circ\text{C}$		70		μV
SVR	Supply Voltage Rejection	$V_I = 12$ to 23 V $f = 120\text{Hz}$ $I_O = 40\text{ mA}$ $T_J = 25^\circ\text{C}$	36	44		dB
V_d	Dropout Voltage			1.7		V

ELECTRICAL CHARACTERISTICS OF L78L10C (refer to the test circuits, $T_J = 0$ to 125°C , $V_I = 16\text{V}$, $I_O = 40\text{ mA}$, $C_I = 0.33\ \mu\text{F}$, $C_O = 0.1\ \mu\text{F}$ unless otherwise specified).

Symbol	Parameter	Test Conditions	Min.	Typ.	Max.	Unit
V_O	Output Voltage	$T_J = 25^\circ\text{C}$	9.2	10	10.8	V
V_O	Output Voltage	$I_O = 1$ to 40 mA $V_I = 12.5$ to 23 V	9		11	V
		$I_O = 1$ to 70 mA $V_I = 16\text{ V}$	9		11	
ΔV_O	Line Regulation	$V_I = 12.5$ to 23 V $T_J = 25^\circ\text{C}$			230	mV
		$V_I = 13$ to 23 V $T_J = 25^\circ\text{C}$			170	
ΔV_O	Load Regulation	$I_O = 1$ to 100 mA $T_J = 25^\circ\text{C}$			80	mV
		$I_O = 1$ to 40 mA $T_J = 25^\circ\text{C}$			40	
I_d	Quiescent Current	$T_J = 25^\circ\text{C}$			6	mA
		$T_J = 125^\circ\text{C}$			5.5	mA
ΔI_d	Quiescent Current Change	$I_O = 1$ to 40 mA			0.1	mA
		$V_I = 13$ to 23 V			1.5	
eN	Output Noise Voltage	$B = 10\text{Hz}$ to 100KHz $T_J = 25^\circ\text{C}$		60		μV
SVR	Supply Voltage Rejection	$V_I = 14$ to 23 V $f = 120\text{Hz}$ $I_O = 40\text{ mA}$ $T_J = 25^\circ\text{C}$	37	45		dB
V_d	Dropout Voltage			1.7		V

ELECTRICAL CHARACTERISTICS OF L78L12C (refer to the test circuits, $T_J = 0$ to 125°C , $V_I = 19\text{V}$, $I_O = 40$ mA, $C_I = 0.33$ μF , $C_O = 0.1$ μF unless otherwise specified).

Symbol	Parameter	Test Conditions	Min.	Typ.	Max.	Unit
V_O	Output Voltage	$T_J = 25^\circ\text{C}$	11.1	12	12.9	V
V_O	Output Voltage	$I_O = 1$ to 40 mA $V_I = 14.5$ to 27 V	10.8		13.2	V
		$I_O = 1$ to 70 mA $V_I = 19$ V	10.8		13.2	
ΔV_O	Line Regulation	$V_I = 14.5$ to 27 V $T_J = 25^\circ\text{C}$			250	mV
		$V_I = 16$ to 27 V $T_J = 25^\circ\text{C}$			200	
ΔV_O	Load Regulation	$I_O = 1$ to 100 mA $T_J = 25^\circ\text{C}$			100	mV
		$I_O = 1$ to 40 mA $T_J = 25^\circ\text{C}$			50	
I_d	Quiescent Current	$T_J = 25^\circ\text{C}$			6.5	mA
		$T_J = 125^\circ\text{C}$			6	mA
ΔI_d	Quiescent Current Change	$I_O = 1$ to 40 mA			0.2	mA
		$V_I = 16$ to 27 V			1.5	
eN	Output Noise Voltage	$B = 10\text{Hz}$ to 100KHz $T_J = 25^\circ\text{C}$		80		μV
SVR	Supply Voltage Rejection	$V_I = 15$ to 25 V $f = 120\text{Hz}$ $I_O = 40$ mA $T_J = 25^\circ\text{C}$	36	42		dB
V_d	Dropout Voltage			1.7		V

ELECTRICAL CHARACTERISTICS OF L78L15C (refer to the test circuits, $T_J = 0$ to 125°C , $V_I = 23\text{V}$, $I_O = 40$ mA, $C_I = 0.33$ μF , $C_O = 0.1$ μF unless otherwise specified).

Symbol	Parameter	Test Conditions	Min.	Typ.	Max.	Unit
V_O	Output Voltage	$T_J = 25^\circ\text{C}$	13.8	15	16.2	V
V_O	Output Voltage	$I_O = 1$ to 40 mA $V_I = 17.5$ to 30 V	13.5		16.5	V
		$I_O = 1$ to 70 mA $V_I = 23$ V	13.5		16.5	
ΔV_O	Line Regulation	$V_I = 17.5$ to 30 V $T_J = 25^\circ\text{C}$			300	mV
		$V_I = 20$ to 30 V $T_J = 25^\circ\text{C}$			250	
ΔV_O	Load Regulation	$I_O = 1$ to 100 mA $T_J = 25^\circ\text{C}$			150	mV
		$I_O = 1$ to 40 mA $T_J = 25^\circ\text{C}$			75	
I_d	Quiescent Current	$T_J = 25^\circ\text{C}$			6.5	mA
		$T_J = 125^\circ\text{C}$			6	mA
ΔI_d	Quiescent Current Change	$I_O = 1$ to 40 mA			0.2	mA
		$V_I = 20$ to 30 V			1.5	
eN	Output Noise Voltage	$B = 10\text{Hz}$ to 100KHz $T_J = 25^\circ\text{C}$		90		μV
SVR	Supply Voltage Rejection	$V_I = 18.5$ to 28.5 V $f = 120\text{Hz}$ $I_O = 40$ mA $T_J = 25^\circ\text{C}$	33	39		dB
V_d	Dropout Voltage			1.7		V

L78L00 SERIES

ELECTRICAL CHARACTERISTICS OF L78L18C (refer to the test circuits, $T_J = 0$ to 125°C , $V_I = 27\text{V}$, $I_O = 40$ mA, $C_I = 0.33$ μF , $C_O = 0.1$ μF unless otherwise specified).

Symbol	Parameter	Test Conditions	Min.	Typ.	Max.	Unit
V_O	Output Voltage	$T_J = 25^\circ\text{C}$	16.6	18	19.4	V
V_O	Output Voltage	$I_O = 1$ to 40 mA $V_I = 22$ to 33 V	16.2		19.8	V
		$I_O = 1$ to 70 mA $V_I = 27$ V	16.2		19.8	
ΔV_O	Line Regulation	$V_I = 22$ to 33 V $T_J = 25^\circ\text{C}$			320	mV
		$V_I = 22$ to 33 V $T_J = 25^\circ\text{C}$			270	
ΔV_O	Load Regulation	$I_O = 1$ to 100 mA $T_J = 25^\circ\text{C}$			170	mV
		$I_O = 1$ to 40 mA $T_J = 25^\circ\text{C}$			85	
I_d	Quiescent Current	$T_J = 25^\circ\text{C}$			6.5	mA
		$T_J = 125^\circ\text{C}$			6	mA
ΔI_d	Quiescent Current Change	$I_O = 1$ to 40 mA			0.2	mA
		$V_I = 23$ to 33 V			1.5	
eN	Output Noise Voltage	B = 10Hz to 100KHz $T_J = 25^\circ\text{C}$		120		μV
SVR	Supply Voltage Rejection	$V_I = 23$ to 33 V $f = 120\text{Hz}$ $I_O = 40$ mA $T_J = 25^\circ\text{C}$	32	38		dB
V_d	Dropout Voltage			1.7		V

ELECTRICAL CHARACTERISTICS OF L78L20C (refer to the test circuits, $T_J = 0$ to 125°C , $V_I = 29\text{V}$, $I_O = 40$ mA, $C_I = 0.33$ μF , $C_O = 0.1$ μF unless otherwise specified)

Symbol	Parameter	Test Conditions	Min.	Typ.	Max.	Unit
V_O	Output Voltage	$T_J = 25^\circ\text{C}$	18.4	20	21.6	V
V_O	Output Voltage	$I_O = 1$ to 40 mA $V_I = 24$ to 33 V	18		22	V
		$I_O = 1$ to 70 mA $V_I = 29$ V	18		22	
ΔV_O	Line Regulation	$V_I = 22.5$ to 34 V $T_J = 25^\circ\text{C}$			330	mV
		$V_I = 24$ to 34 V $T_J = 25^\circ\text{C}$			280	
ΔV_O	Load Regulation	$I_O = 1$ to 100 mA $T_J = 25^\circ\text{C}$			180	mV
		$I_O = 1$ to 40 mA $T_J = 25^\circ\text{C}$			90	
I_d	Quiescent Current	$T_J = 25^\circ\text{C}$			6.5	mA
		$T_J = 125^\circ\text{C}$			6	mA
ΔI_d	Quiescent Current Change	$I_O = 1$ to 40 mA			0.2	mA
		$V_I = 25$ to 33 V			1.5	
eN	Output Noise Voltage	B = 10Hz to 100KHz $T_J = 25^\circ\text{C}$		120		μV
SVR	Supply Voltage Rejection	$V_I = 25$ to 35 V $f = 120\text{Hz}$ $I_O = 40$ mA $T_J = 25^\circ\text{C}$	31	38		dB
V_d	Dropout Voltage			1.7		V

ELECTRICAL CHARACTERISTICS OF L78L24C (refer to the test circuits, $T_J = 0$ to 125°C , $V_I = 33\text{V}$, $I_O = 40$ mA, $C_I = 0.33$ μF , $C_O = 0.1$ μF unless otherwise specified).

Symbol	Parameter	Test Conditions	Min.	Typ.	Max.	Unit
V_O	Output Voltage	$T_J = 25^\circ\text{C}$	22.1	24	25.9	V
V_O	Output Voltage	$I_O = 1$ to 40 mA $V_I = 27$ to 38 V	21.6		26.4	V
		$I_O = 1$ to 70 mA $V_I = 33$ V	21.6		26.4	
ΔV_O	Line Regulation	$V_I = 27$ to 38 V $T_J = 25^\circ\text{C}$			350	mV
		$V_I = 28$ to 38 V $T_J = 25^\circ\text{C}$			300	
ΔV_O	Load Regulation	$I_O = 1$ to 100 mA $T_J = 25^\circ\text{C}$			200	mV
		$I_O = 1$ to 40 mA $T_J = 25^\circ\text{C}$			100	
I_d	Quiescent Current	$T_J = 25^\circ\text{C}$			6.5	mA
		$T_J = 125^\circ\text{C}$			6	mA
ΔI_d	Quiescent Current Change	$I_O = 1$ to 40 mA			0.2	mA
		$V_I = 28$ to 38 V			1.5	
eN	Output Noise Voltage	B = 10Hz to 100KHz $T_J = 25^\circ\text{C}$		200		μV
SVR	Supply Voltage Rejection	$V_I = 29$ to 35 V $f = 120\text{Hz}$ $I_O = 40$ mA $T_J = 25^\circ\text{C}$	30	37		dB
V_d	Dropout Voltage			1.7		V

ELECTRICAL CHARACTERISTICS OF L78L33AB AND L78L33AC

(refer to the test circuits, $V_I = 8.3\text{V}$, $I_O = 40$ mA, $C_I = 0.33$ μF , $C_O = 0.1$ μF , $T_J = 0$ to 125°C for L78L33AC, $T_J = -40$ to 125°C for L78L33AB, unless otherwise specified)

Symbol	Parameter	Test Conditions	Min.	Typ.	Max.	Unit
V_O	Output Voltage	$T_J = 25^\circ\text{C}$	3.168	3.3	3.432	V
V_O	Output Voltage	$I_O = 1$ to 40 mA $V_I = 5.3$ to 20 V	3.135		3.465	V
		$I_O = 1$ to 70 mA $V_I = 8.3$ V	3.135		3.465	
ΔV_O	Line Regulation	$V_I = 5.3$ to 20 V $T_J = 25^\circ\text{C}$			150	mV
		$V_I = 6.3$ to 20 V $T_J = 25^\circ\text{C}$			100	
ΔV_O	Load Regulation	$I_O = 1$ to 100 mA $T_J = 25^\circ\text{C}$			60	mV
		$I_O = 1$ to 40 mA $T_J = 25^\circ\text{C}$			30	
I_d	Quiescent Current	$T_J = 25^\circ\text{C}$			6	mA
		$T_J = 125^\circ\text{C}$			5.5	mA
ΔI_d	Quiescent Current Change	$I_O = 1$ to 40 mA			0.1	mA
		$V_I = 6.3$ to 20 V			1.5	
eN	Output Noise Voltage	B = 10Hz to 100KHz $T_J = 25^\circ\text{C}$		40		μV
SVR	Supply Voltage Rejection	$V_I = 6.3$ to 16.3 V $f = 120\text{Hz}$ $I_O = 40$ mA $T_J = 25^\circ\text{C}$	41	49		dB
V_d	Dropout Voltage			1.7		V

L78L00 SERIES

ELECTRICAL CHARACTERISTICS OF L78L05AB AND L78L05AC

(refer to the test circuits, $V_I = 10V$, $I_O = 40\text{ mA}$, $C_I = 0.33\text{ }\mu\text{F}$, $C_O = 0.1\text{ }\mu\text{F}$, $T_J = 0\text{ to }125^\circ\text{C}$ for L78L05AC, $T_J = -40\text{ to }125^\circ\text{C}$ for L78L05AB, unless otherwise specified)

Symbol	Parameter	Test Conditions	Min.	Typ.	Max.	Unit
V_O	Output Voltage	$T_J = 25^\circ\text{C}$	4.8	5	5.2	V
V_O	Output Voltage	$I_O = 1\text{ to }40\text{ mA}$ $V_I = 7\text{ to }20\text{ V}$	4.75		5.25	V
		$I_O = 1\text{ to }70\text{ mA}$ $V_I = 10\text{ V}$	4.75		5.25	
ΔV_O	Line Regulation	$V_I = 7\text{ to }20\text{ V}$ $T_J = 25^\circ\text{C}$			150	mV
		$V_I = 8\text{ to }20\text{ V}$ $T_J = 25^\circ\text{C}$			100	
ΔV_O	Load Regulation	$I_O = 1\text{ to }100\text{ mA}$ $T_J = 25^\circ\text{C}$			60	mV
		$I_O = 1\text{ to }40\text{ mA}$ $T_J = 25^\circ\text{C}$			30	
I_d	Quiescent Current	$T_J = 25^\circ\text{C}$			6	mA
		$T_J = 125^\circ\text{C}$			5.5	mA
ΔI_d	Quiescent Current Change	$I_O = 1\text{ to }40\text{ mA}$			0.1	mA
		$V_I = 8\text{ to }20\text{ V}$			1.5	
eN	Output Noise Voltage	$B = 10\text{Hz to }100\text{KHz}$ $T_J = 25^\circ\text{C}$		40		μV
SVR	Supply Voltage Rejection	$V_I = 8\text{ to }18\text{ V}$ $f = 120\text{Hz}$ $I_O = 40\text{ mA}$ $T_J = 25^\circ\text{C}$	41	49		dB
V_d	Dropout Voltage			1.7		V

ELECTRICAL CHARACTERISTICS OF L78L06AB AND L78L06AC

(refer to the test circuits, $V_I = 12V$, $I_O = 40\text{ mA}$, $C_I = 0.33\text{ }\mu\text{F}$, $C_O = 0.1\text{ }\mu\text{F}$, $T_J = 0\text{ to }125^\circ\text{C}$ for L78L06AC, $T_J = -40\text{ to }125^\circ\text{C}$ for L78L06AB, unless otherwise specified)

Symbol	Parameter	Test Conditions	Min.	Typ.	Max.	Unit
V_O	Output Voltage	$T_J = 25^\circ\text{C}$	5.76	6	6.24	V
V_O	Output Voltage	$I_O = 1\text{ to }40\text{ mA}$ $V_I = 8.5\text{ to }20\text{ V}$	5.7		6.3	V
		$I_O = 1\text{ to }70\text{ mA}$ $V_I = 12\text{ V}$	5.7		6.3	
ΔV_O	Line Regulation	$V_I = 8.5\text{ to }20\text{ V}$ $T_J = 25^\circ\text{C}$			150	mV
		$V_I = 9\text{ to }20\text{ V}$ $T_J = 25^\circ\text{C}$			100	
ΔV_O	Load Regulation	$I_O = 1\text{ to }100\text{ mA}$ $T_J = 25^\circ\text{C}$			60	mV
		$I_O = 1\text{ to }40\text{ mA}$ $T_J = 25^\circ\text{C}$			30	
I_d	Quiescent Current	$T_J = 25^\circ\text{C}$			6	mA
		$T_J = 125^\circ\text{C}$			5.5	mA
ΔI_d	Quiescent Current Change	$I_O = 1\text{ to }40\text{ mA}$			0.1	mA
		$V_I = 9\text{ to }20\text{ V}$			1.5	
eN	Output Noise Voltage	$B = 10\text{Hz to }100\text{KHz}$ $T_J = 25^\circ\text{C}$		50		μV
SVR	Supply Voltage Rejection	$V_I = 9\text{ to }20\text{ V}$ $f = 120\text{Hz}$ $I_O = 40\text{ mA}$ $T_J = 25^\circ\text{C}$	39	46		dB
V_d	Dropout Voltage			1.7		V

ELECTRICAL CHARACTERISTICS OF L78L08AB AND L78L08AC(refer to the test circuits, $V_I = 14\text{V}$, $I_O = 40\text{ mA}$, $C_I = 0.33\text{ }\mu\text{F}$, $C_O = 0.1\text{ }\mu\text{F}$, $T_J = 0\text{ to }125^\circ\text{C}$ for L78L08AC, $T_J = -40\text{ to }125^\circ\text{C}$ for L78L08AB, unless otherwise specified)

Symbol	Parameter	Test Conditions	Min.	Typ.	Max.	Unit
V_O	Output Voltage	$T_J = 25^\circ\text{C}$	7.68	8	8.32	V
V_O	Output Voltage	$I_O = 1\text{ to }40\text{ mA}$ $V_I = 10.5\text{ to }23\text{ V}$	7.6		8.4	V
		$I_O = 1\text{ to }70\text{ mA}$ $V_I = 14\text{ V}$	7.6		8.4	
ΔV_O	Line Regulation	$V_I = 10.5\text{ to }23\text{ V}$ $T_J = 25^\circ\text{C}$			175	mV
		$V_I = 11\text{ to }23\text{ V}$ $T_J = 25^\circ\text{C}$			125	
ΔV_O	Load Regulation	$I_O = 1\text{ to }100\text{ mA}$ $T_J = 25^\circ\text{C}$			80	mV
		$I_O = 1\text{ to }40\text{ mA}$ $T_J = 25^\circ\text{C}$			40	
I_d	Quiescent Current	$T_J = 25^\circ\text{C}$			6	mA
		$T_J = 125^\circ\text{C}$			5.5	mA
ΔI_d	Quiescent Current Change	$I_O = 1\text{ to }40\text{ mA}$			0.1	mA
		$V_I = 11\text{ to }23\text{ V}$			1.5	
eN	Output Noise Voltage	$B = 10\text{Hz to }100\text{KHz}$ $T_J = 25^\circ\text{C}$		60		μV
SVR	Supply Voltage Rejection	$V_I = 12\text{ to }23\text{ V}$ $f = 120\text{Hz}$ $I_O = 40\text{ mA}$ $T_J = 25^\circ\text{C}$	37	45		dB
V_d	Dropout Voltage			1.7		V

ELECTRICAL CHARACTERISTICS OF L78L09AB AND L78L09AC(refer to the test circuits, $V_I = 15\text{V}$, $I_O = 40\text{ mA}$, $C_I = 0.33\text{ }\mu\text{F}$, $C_O = 0.1\text{ }\mu\text{F}$, $T_J = 0\text{ to }125^\circ\text{C}$ for L78L09AC, $T_J = -40\text{ to }125^\circ\text{C}$ for L78L09AB, unless otherwise specified)

Symbol	Parameter	Test Conditions	Min.	Typ.	Max.	Unit
V_O	Output Voltage	$T_J = 25^\circ\text{C}$	8.64	9	9.36	V
V_O	Output Voltage	$I_O = 1\text{ to }40\text{ mA}$ $V_I = 11.5\text{ to }23\text{ V}$	8.55		9.45	V
		$I_O = 1\text{ to }70\text{ mA}$ $V_I = 15\text{ V}$	8.55		9.45	
ΔV_O	Line Regulation	$V_I = 11.5\text{ to }23\text{ V}$ $T_J = 25^\circ\text{C}$			225	mV
		$V_I = 12\text{ to }23\text{ V}$ $T_J = 25^\circ\text{C}$			150	
ΔV_O	Load Regulation	$I_O = 1\text{ to }100\text{ mA}$ $T_J = 25^\circ\text{C}$			80	mV
		$I_O = 1\text{ to }40\text{ mA}$ $T_J = 25^\circ\text{C}$			40	
I_d	Quiescent Current	$T_J = 25^\circ\text{C}$			6	mA
		$T_J = 125^\circ\text{C}$			5.5	mA
ΔI_d	Quiescent Current Change	$I_O = 1\text{ to }40\text{ mA}$			0.1	mA
		$V_I = 12\text{ to }23\text{ V}$			1.5	
eN	Output Noise Voltage	$B = 10\text{Hz to }100\text{KHz}$ $T_J = 25^\circ\text{C}$		70		μV
SVR	Supply Voltage Rejection	$V_I = 12\text{ to }23\text{ V}$ $f = 120\text{Hz}$ $I_O = 40\text{ mA}$ $T_J = 25^\circ\text{C}$	37	44		dB
V_d	Dropout Voltage			1.7		V

L78L00 SERIES

ELECTRICAL CHARACTERISTICS OF L78L10AB AND L78L10AC

(refer to the test circuits, $V_I = 16V$, $I_O = 40\text{ mA}$, $C_I = 0.33\text{ }\mu\text{F}$, $C_O = 0.1\text{ }\mu\text{F}$,
 $T_J = 0\text{ to }125^\circ\text{C}$ for L78L10AC, $T_J = -40\text{ to }125^\circ\text{C}$ for L78L10AB, unless otherwise specified)

Symbol	Parameter	Test Conditions	Min.	Typ.	Max.	Unit
V_O	Output Voltage	$T_J = 25^\circ\text{C}$	9.6	10	10.4	V
V_O	Output Voltage	$I_O = 1\text{ to }40\text{ mA}$ $V_I = 12.5\text{ to }23\text{ V}$	9.5		10.5	V
		$I_O = 1\text{ to }70\text{ mA}$ $V_I = 16\text{ V}$	9.5		10.5	
ΔV_O	Line Regulation	$V_I = 12.5\text{ to }23\text{ V}$ $T_J = 25^\circ\text{C}$			230	mV
		$V_I = 13\text{ to }23\text{ V}$ $T_J = 25^\circ\text{C}$			170	
ΔV_O	Load Regulation	$I_O = 1\text{ to }100\text{ mA}$ $T_J = 25^\circ\text{C}$			80	mV
		$I_O = 1\text{ to }40\text{ mA}$ $T_J = 25^\circ\text{C}$			40	
I_d	Quiescent Current	$T_J = 25^\circ\text{C}$			6	mA
		$T_J = 125^\circ\text{C}$			5.5	mA
ΔI_d	Quiescent Current Change	$I_O = 1\text{ to }40\text{ mA}$			0.1	mA
		$V_I = 13\text{ to }23\text{ V}$			1.5	
eN	Output Noise Voltage	$B = 10\text{Hz to }100\text{KHz}$ $T_J = 25^\circ\text{C}$		60		μV
SVR	Supply Voltage Rejection	$V_I = 14\text{ to }23\text{ V}$ $f = 120\text{Hz}$ $I_O = 40\text{ mA}$ $T_J = 25^\circ\text{C}$	37	45		dB
V_d	Dropout Voltage			1.7		V

ELECTRICAL CHARACTERISTICS OF L78L12AB AND L78L12AC

(refer to the test circuits, $V_I = 19V$, $I_O = 40\text{ mA}$, $C_I = 0.33\text{ }\mu\text{F}$, $C_O = 0.1\text{ }\mu\text{F}$,
 $T_J = 0\text{ to }125^\circ\text{C}$ for L78L12AC, $T_J = -40\text{ to }125^\circ\text{C}$ for L78L12AB, unless otherwise specified)

Symbol	Parameter	Test Conditions	Min.	Typ.	Max.	Unit
V_O	Output Voltage	$T_J = 25^\circ\text{C}$	11.5	12	12.5	V
V_O	Output Voltage	$I_O = 1\text{ to }40\text{ mA}$ $V_I = 14.5\text{ to }27\text{ V}$	11.4		12.6	V
		$I_O = 1\text{ to }70\text{ mA}$ $V_I = 19\text{ V}$	11.4		12.6	
ΔV_O	Line Regulation	$V_I = 14.5\text{ to }27\text{ V}$ $T_J = 25^\circ\text{C}$			250	mV
		$V_I = 16\text{ to }27\text{ V}$ $T_J = 25^\circ\text{C}$			200	
ΔV_O	Load Regulation	$I_O = 1\text{ to }100\text{ mA}$ $T_J = 25^\circ\text{C}$			100	mV
		$I_O = 1\text{ to }40\text{ mA}$ $T_J = 25^\circ\text{C}$			50	
I_d	Quiescent Current	$T_J = 25^\circ\text{C}$			6.5	mA
		$T_J = 125^\circ\text{C}$			6	mA
ΔI_d	Quiescent Current Change	$I_O = 1\text{ to }40\text{ mA}$			0.1	mA
		$V_I = 16\text{ to }27\text{ V}$			1.5	
eN	Output Noise Voltage	$B = 10\text{Hz to }100\text{KHz}$ $T_J = 25^\circ\text{C}$		80		μV
SVR	Supply Voltage Rejection	$V_I = 15\text{ to }25\text{ V}$ $f = 120\text{Hz}$ $I_O = 40\text{ mA}$ $T_J = 25^\circ\text{C}$	37	42		dB
V_d	Dropout Voltage			1.7		V

ELECTRICAL CHARACTERISTICS OF L78L15AB AND L78L15AC(refer to the test circuits, $V_I = 19V$, $I_O = 40\text{ mA}$, $C_I = 0.33\text{ }\mu\text{F}$, $C_O = 0.1\text{ }\mu\text{F}$, $T_J = 0\text{ to }125^\circ\text{C}$ for L78L15AC, $T_J = -40\text{ to }125^\circ\text{C}$ for L78L15AB, unless otherwise specified)

Symbol	Parameter	Test Conditions	Min.	Typ.	Max.	Unit
V_O	Output Voltage	$T_J = 25^\circ\text{C}$	14.4	15	15.6	V
V_O	Output Voltage	$I_O = 1\text{ to }40\text{ mA}$ $V_I = 17.5\text{ to }30\text{ V}$	14.25		15.75	V
		$I_O = 1\text{ to }70\text{ mA}$ $V_I = 23\text{ V}$	14.25		15.75	
ΔV_O	Line Regulation	$V_I = 17.5\text{ to }30\text{ V}$ $T_J = 25^\circ\text{C}$			300	mV
		$V_I = 20\text{ to }30\text{ V}$ $T_J = 25^\circ\text{C}$			250	
ΔV_O	Load Regulation	$I_O = 1\text{ to }100\text{ mA}$ $T_J = 25^\circ\text{C}$			150	mV
		$I_O = 1\text{ to }40\text{ mA}$ $T_J = 25^\circ\text{C}$			75	
I_d	Quiescent Current	$T_J = 25^\circ\text{C}$			6.5	mA
		$T_J = 125^\circ\text{C}$			6	mA
ΔI_d	Quiescent Current Change	$I_O = 1\text{ to }40\text{ mA}$			0.1	mA
		$V_I = 20\text{ to }30\text{ V}$			1.5	
eN	Output Noise Voltage	$B = 10\text{Hz to }100\text{KHz}$ $T_J = 25^\circ\text{C}$		90		μV
SVR	Supply Voltage Rejection	$V_I = 18.5\text{ to }28.5\text{ V}$ $f = 120\text{Hz}$ $I_O = 40\text{ mA}$ $T_J = 25^\circ\text{C}$	34	39		dB
V_d	Dropout Voltage			1.7		V

ELECTRICAL CHARACTERISTICS OF L78L18AB AND L78L18AC(refer to the test circuits, $V_I = 27V$, $I_O = 40\text{ mA}$, $C_I = 0.33\text{ }\mu\text{F}$, $C_O = 0.1\text{ }\mu\text{F}$, $T_J = 0\text{ to }125^\circ\text{C}$ for L78L18AC, $T_J = -40\text{ to }125^\circ\text{C}$ for L78L18AB, unless otherwise specified)

Symbol	Parameter	Test Conditions	Min.	Typ.	Max.	Unit
V_O	Output Voltage	$T_J = 25^\circ\text{C}$	17.3	18	18.7	V
V_O	Output Voltage	$I_O = 1\text{ to }40\text{ mA}$ $V_I = 22\text{ to }33\text{ V}$	17.1		18.9	V
		$I_O = 1\text{ to }70\text{ mA}$ $V_I = 27\text{ V}$	17.1		18.9	
ΔV_O	Line Regulation	$V_I = 22\text{ to }33\text{ V}$ $T_J = 25^\circ\text{C}$			320	mV
		$V_I = 22\text{ to }33\text{ V}$ $T_J = 25^\circ\text{C}$			270	
ΔV_O	Load Regulation	$I_O = 1\text{ to }100\text{ mA}$ $T_J = 25^\circ\text{C}$			170	mV
		$I_O = 1\text{ to }40\text{ mA}$ $T_J = 25^\circ\text{C}$			85	
I_d	Quiescent Current	$T_J = 25^\circ\text{C}$			6.5	mA
		$T_J = 125^\circ\text{C}$			6	mA
ΔI_d	Quiescent Current Change	$I_O = 1\text{ to }40\text{ mA}$			0.1	mA
		$V_I = 23\text{ to }33\text{ V}$			1.5	
eN	Output Noise Voltage	$B = 10\text{Hz to }100\text{KHz}$ $T_J = 25^\circ\text{C}$		120		μV
SVR	Supply Voltage Rejection	$V_I = 23\text{ to }33\text{ V}$ $f = 120\text{Hz}$ $I_O = 40\text{ mA}$ $T_J = 25^\circ\text{C}$	33	38		dB
V_d	Dropout Voltage			1.7		V

L78L00 SERIES

ELECTRICAL CHARACTERISTICS OF L78L20AB AND L78L20AC

(refer to the test circuits, $V_I = 29V$, $I_O = 40\text{ mA}$, $C_I = 0.33\text{ }\mu\text{F}$, $C_O = 0.1\text{ }\mu\text{F}$,
 $T_J = 0\text{ to }125^\circ\text{C}$ for L78L20AC, $T_J = -40\text{ to }125^\circ\text{C}$ for L78L20AB, unless otherwise specified)

Symbol	Parameter	Test Conditions	Min.	Typ.	Max.	Unit
V_O	Output Voltage	$T_J = 25^\circ\text{C}$	19.2	20	20.8	V
V_O	Output Voltage	$I_O = 1\text{ to }40\text{ mA}$ $V_I = 24\text{ to }33\text{ V}$	19		21	V
		$I_O = 1\text{ to }70\text{ mA}$ $V_I = 29\text{ V}$	19		21	
ΔV_O	Line Regulation	$V_I = 22.5\text{ to }34\text{ V}$ $T_J = 25^\circ\text{C}$			330	mV
		$V_I = 24\text{ to }34\text{ V}$ $T_J = 25^\circ\text{C}$			280	
ΔV_O	Load Regulation	$I_O = 1\text{ to }100\text{ mA}$ $T_J = 25^\circ\text{C}$			180	mV
		$I_O = 1\text{ to }40\text{ mA}$ $T_J = 25^\circ\text{C}$			90	
I_d	Quiescent Current	$T_J = 25^\circ\text{C}$			6.5	mA
		$T_J = 125^\circ\text{C}$			6	mA
ΔI_d	Quiescent Current Change	$I_O = 1\text{ to }40\text{ mA}$			0.1	mA
		$V_I = 25\text{ to }33\text{ V}$			1.5	
eN	Output Noise Voltage	$B = 10\text{Hz to }100\text{KHz}$ $T_J = 25^\circ\text{C}$		120		μV
SVR	Supply Voltage Rejection	$V_I = 25\text{ to }35\text{ V}$ $f = 120\text{Hz}$ $I_O = 40\text{ mA}$ $T_J = 25^\circ\text{C}$	32	38		dB
V_d	Dropout Voltage			1.7		V

ELECTRICAL CHARACTERISTICS OF L78L24AB AND L78L24AC

(refer to the test circuits, $V_I = 27V$, $I_O = 40\text{ mA}$, $C_I = 0.33\text{ }\mu\text{F}$, $C_O = 0.1\text{ }\mu\text{F}$,
 $T_J = 0\text{ to }125^\circ\text{C}$ for L78L24AC, $T_J = -40\text{ to }125^\circ\text{C}$ for L78L24AB, unless otherwise specified)

Symbol	Parameter	Test Conditions	Min.	Typ.	Max.	Unit
V_O	Output Voltage	$T_J = 25^\circ\text{C}$	23	24	25	V
V_O	Output Voltage	$I_O = 1\text{ to }40\text{ mA}$ $V_I = 27\text{ to }38\text{ V}$	22.8		25.2	V
		$I_O = 1\text{ to }70\text{ mA}$ $V_I = 33\text{ V}$	22.8		25.2	
ΔV_O	Line Regulation	$V_I = 27\text{ to }38\text{ V}$ $T_J = 25^\circ\text{C}$			350	mV
		$V_I = 28\text{ to }38\text{ V}$ $T_J = 25^\circ\text{C}$			300	
ΔV_O	Load Regulation	$I_O = 1\text{ to }100\text{ mA}$ $T_J = 25^\circ\text{C}$			200	mV
		$I_O = 1\text{ to }40\text{ mA}$ $T_J = 25^\circ\text{C}$			100	
I_d	Quiescent Current	$T_J = 25^\circ\text{C}$			6.5	mA
		$T_J = 125^\circ\text{C}$			6	mA
ΔI_d	Quiescent Current Change	$I_O = 1\text{ to }40\text{ mA}$			0.1	mA
		$V_I = 28\text{ to }38\text{ V}$			1.5	
eN	Output Noise Voltage	$B = 10\text{Hz to }100\text{KHz}$ $T_J = 25^\circ\text{C}$		200		μV
SVR	Supply Voltage Rejection	$V_I = 23\text{ to }33\text{ V}$ $f = 120\text{Hz}$ $I_O = 40\text{ mA}$ $T_J = 25^\circ\text{C}$	31	37		dB
V_d	Dropout Voltage			1.7		V

Figure 1 : L78L05/12 Output Voltage vs Ambient Temperature

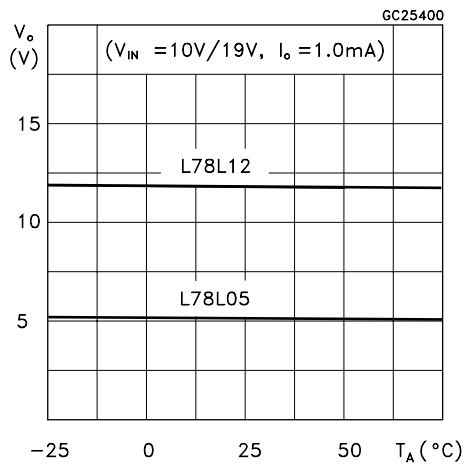

Figure 4 : L78L05/12 Quiescent Current vs Output Current

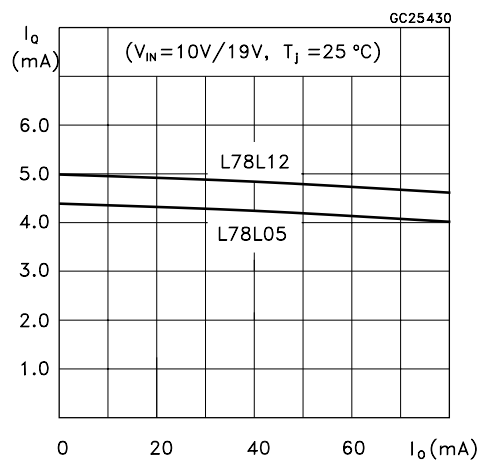

Figure 2 : L78L05/12/24 Load Characteristics

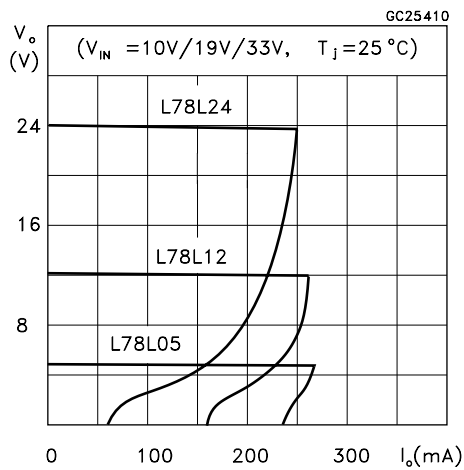

Figure 5 : L78L05 Quiescent Current vs Input Voltage

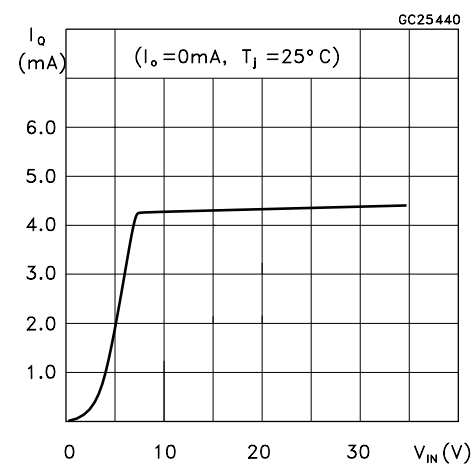

Figure 3 : L78L05/12/24 Thermal Shutdown

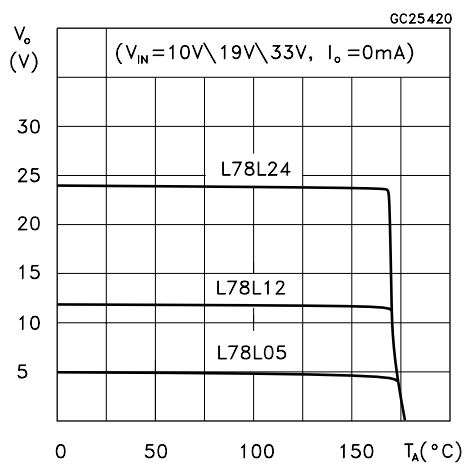
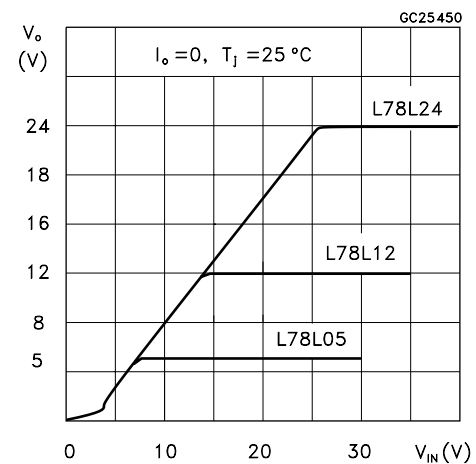

Figure 6 : L78L05/12/24 Output Characteristics



L78L00 SERIES

Figure 7 : L78L05/12/24 Ripple Rejection

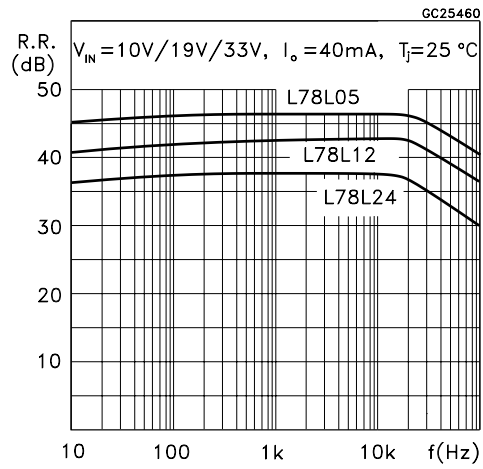

Figure 9 : L78L00 Series Short Circuit Output Current

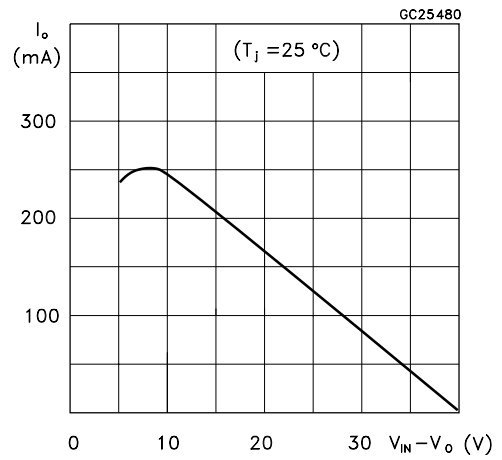
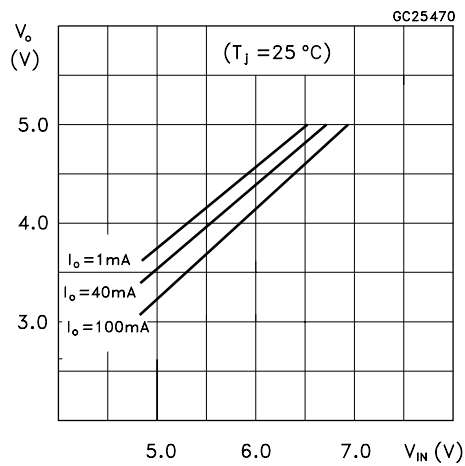

Figure 8 : L78L05 Dropout Characteristics



TYPICAL APPLICATIONS

Table 10 : High Output Current Short Circuit Protected

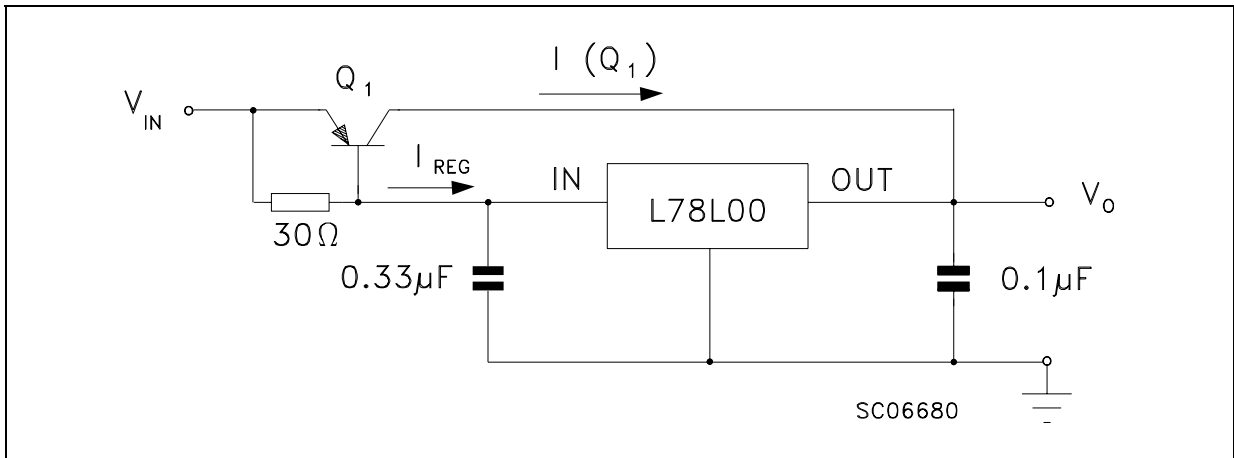

Figure 11 : Edit Boost Circuit

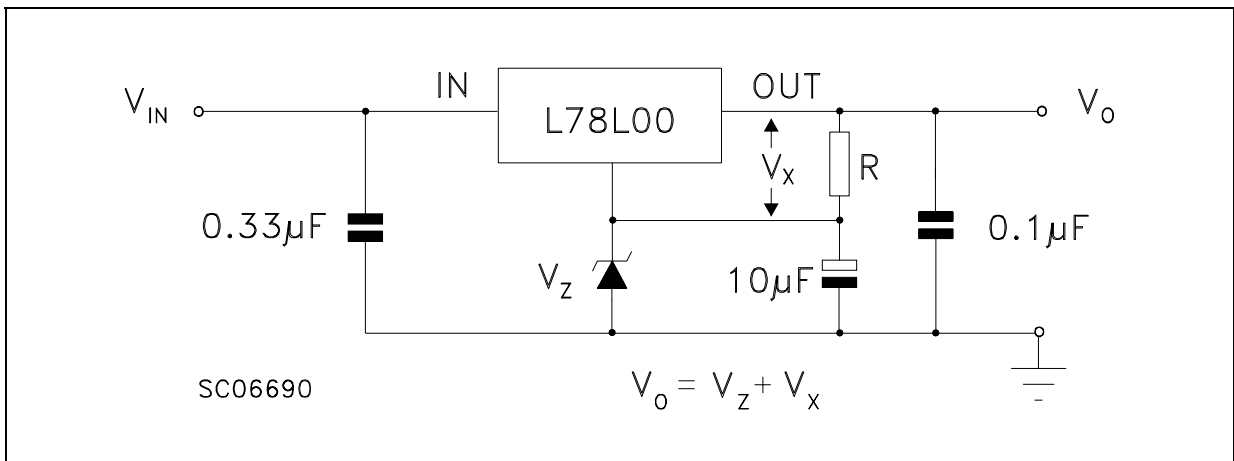
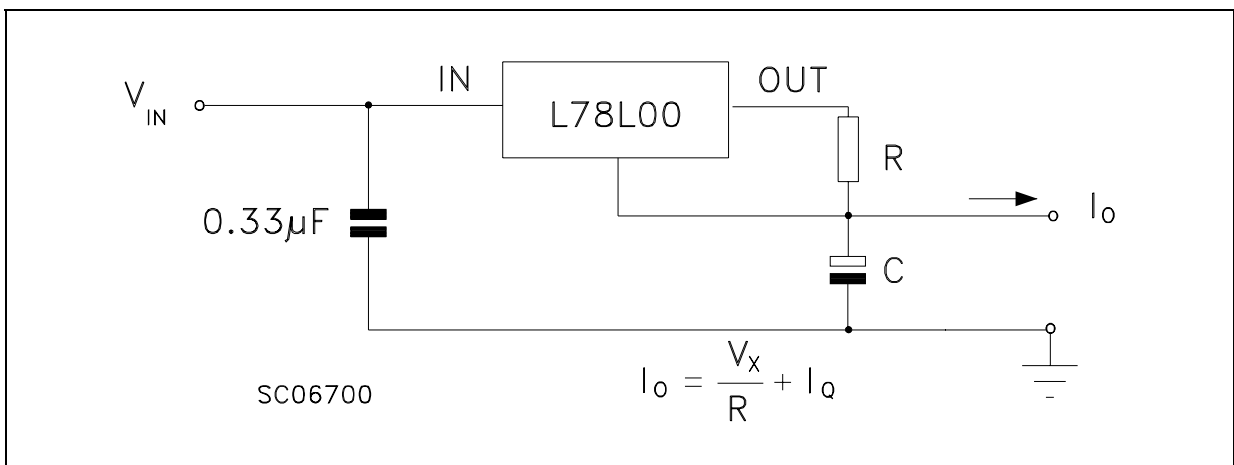
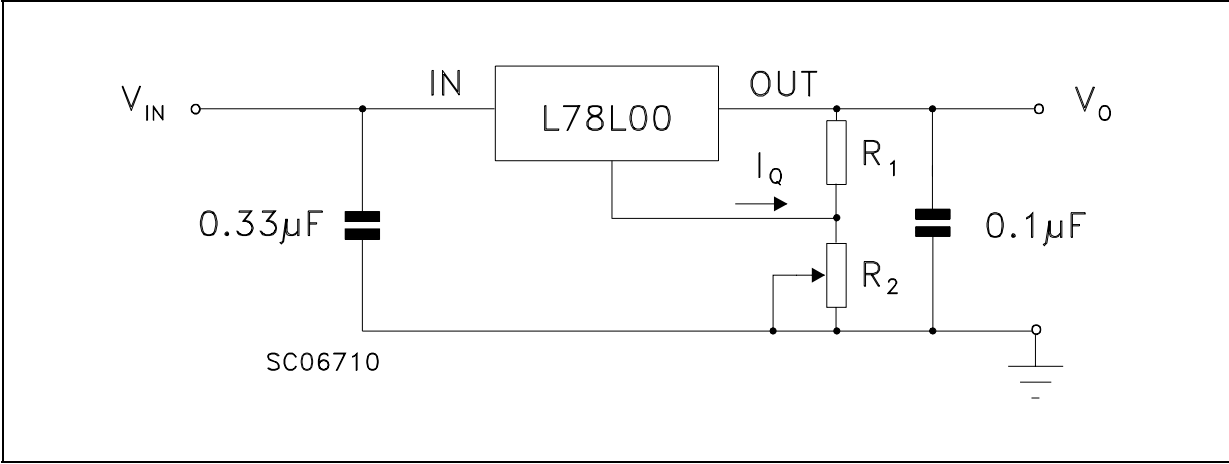

Figure 12 : Current Regulator



L78L00 SERIES

Figure 13 : Adjustable Output Regulator



SO-8 MECHANICAL DATA

DIM.	mm.			inch		
	MIN.	TYP.	MAX.	MIN.	TYP.	MAX.
A	1.35		1.75	0.053		0.069
A1	0.10		0.25	0.04		0.010
A2	1.10		1.65	0.043		0.065
B	0.33		0.51	0.013		0.020
C	0.19		0.25	0.007		0.010
D	4.80		5.00	0.189		0.197
E	3.80		4.00	0.150		0.157
e		1.27			0.050	
H	5.80		6.20	0.228		0.244
h	0.25		0.50	0.010		0.020
L	0.40		1.27	0.016		0.050
k	8° (max.)					
ddd			0.1			0.04

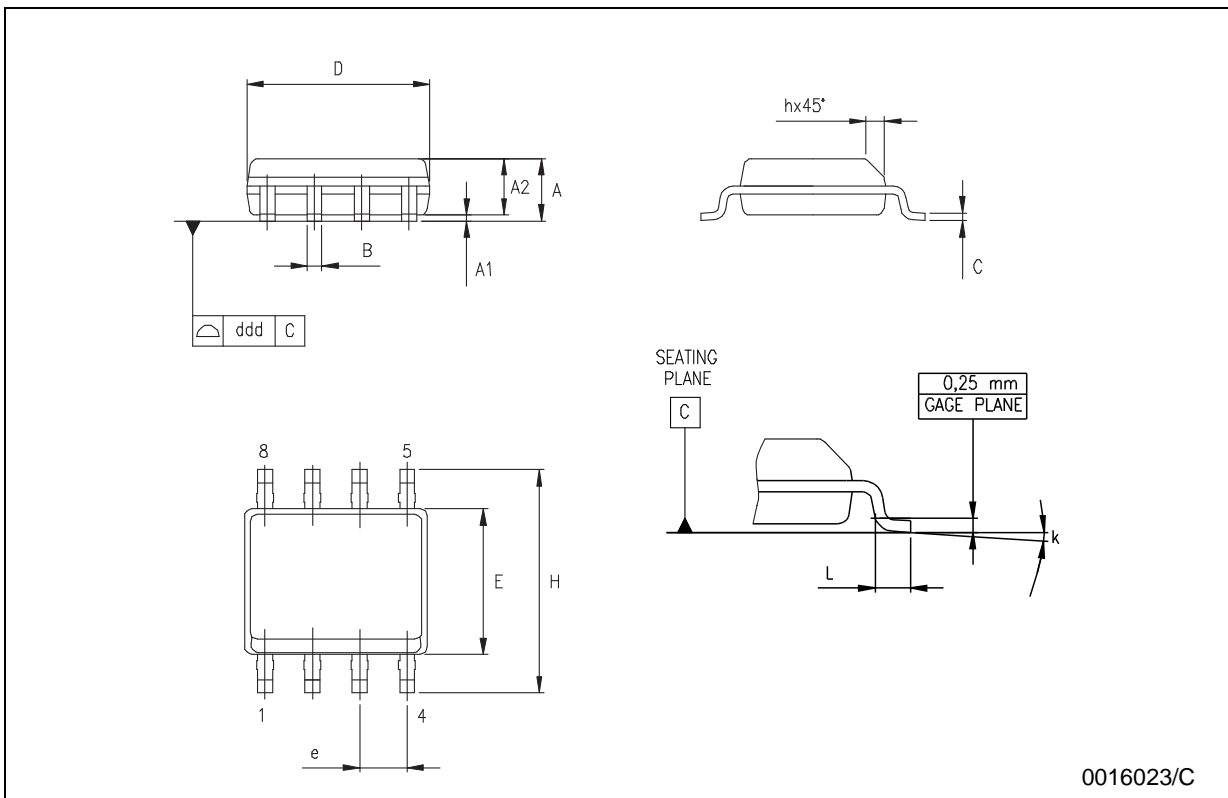

SOT-89 MECHANICAL DATA

DIM.	mm.			mils		
	MIN.	TYP	MAX.	MIN.	TYP.	MAX.
A	1.4		1.6	55.1		63.0
B	0.44		0.56	17.3		22.0
B1	0.36		0.48	14.2		18.9
C	0.35		0.44	13.8		17.3
C1	0.35		0.44	13.8		17.3
D	4.4		4.6	173.2		181.1
D1	1.62		1.83	63.8		72.0
E	2.29		2.6	90.2		102.4
e	1.42		1.57	55.9		61.8
e1	2.92		3.07	115.0		120.9
H	3.94		4.25	155.1		167.3
L	0.89		1.2	35.0		47.2

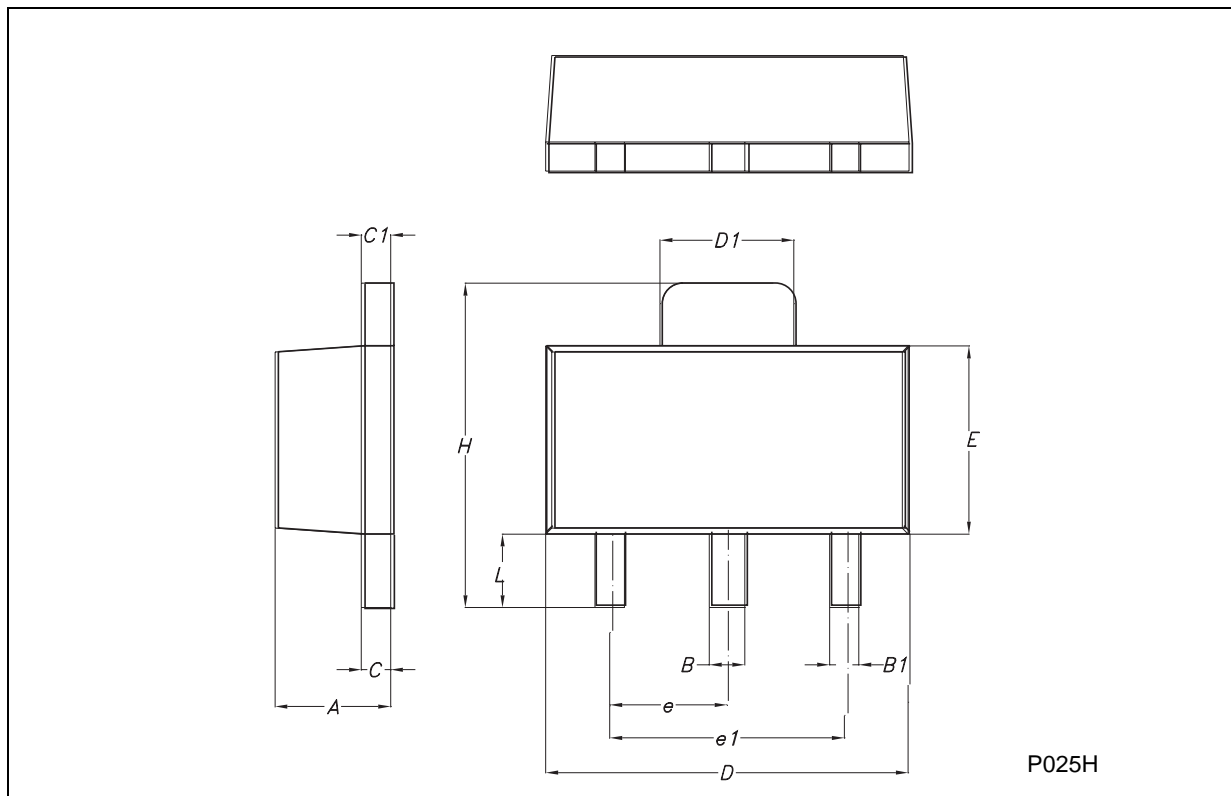

P025H

TO-92 MECHANICA DATA

DIM.	mm.			mils		
	MIN.	TYP	MAX.	MIN.	TYP.	MAX.
A	4.32		4.95	170.1		194.9
b	0.36		0.51	14.2		20.1
D	4.45		4.95	175.2		194.9
E	3.30		3.94	129.9		155.1
e	2.41		2.67	94.9		105.1
e1	1.14		1.40	44.9		55.1
L	12.7		15.49	500.0		609.8
R	2.16		2.41	85.0		94.9
S1	0.92		1.52	36.2		59.8
W	0.41		0.56	16.1		22.0

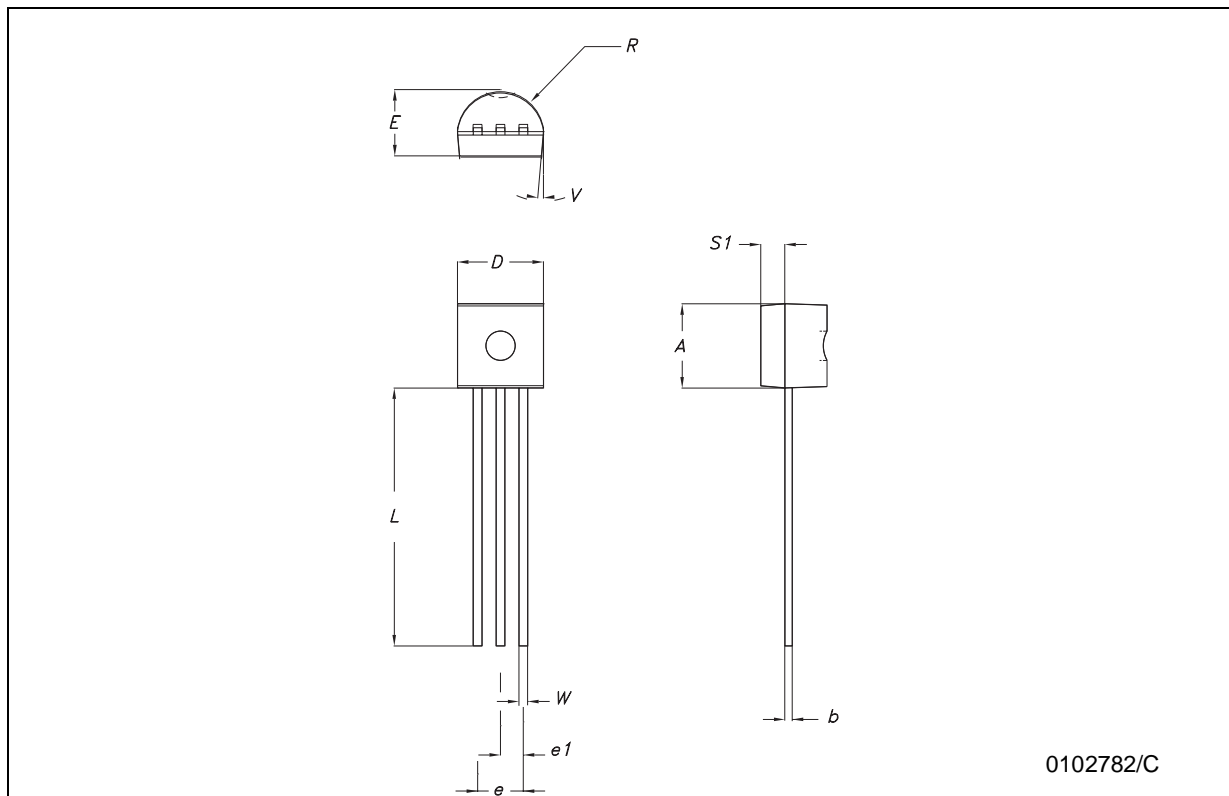

Tape & Reel SO-8 MECHANICAL DATA

DIM.	mm.			inch		
	MIN.	TYP	MAX.	MIN.	TYP.	MAX.
A			330			12.992
C	12.8		13.2	0.504		0.519
D	20.2			0.795		
N	60			2.362		
T			22.4			0.882
Ao	8.1		8.5	0.319		0.335
Bo	5.5		5.9	0.216		0.232
Ko	2.1		2.3	0.082		0.090
Po	3.9		4.1	0.153		0.161
P	7.9		8.1	0.311		0.319

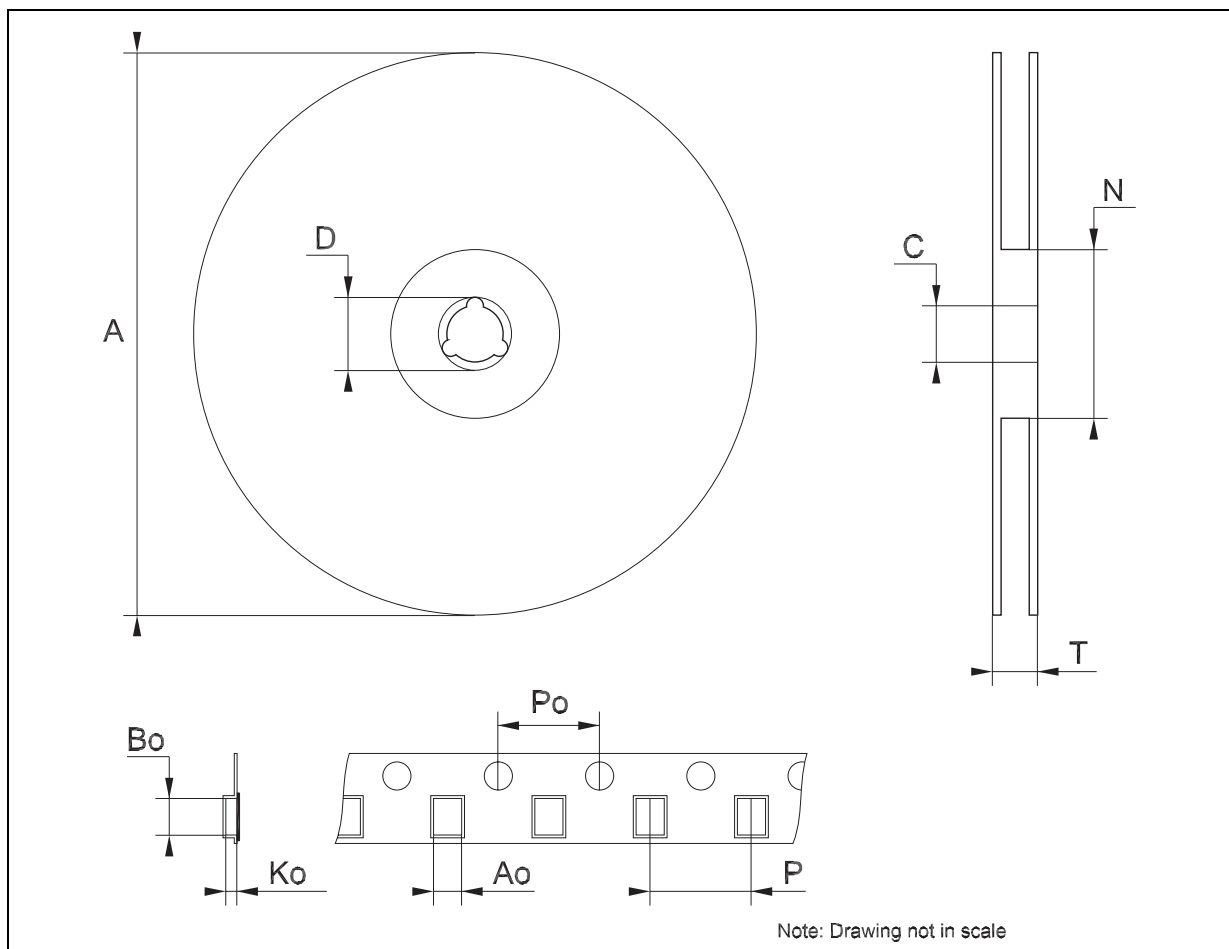

Tape & Reel SOT89 MECHANICAL DATA

DIM.	mm.			inch		
	MIN.	TYP	MAX.	MIN.	TYP.	MAX.
A			180			7.086
C	12.8	13.0	13.2	0.504	0.512	0.519
D	20.2			0.795		
N	60			2.362		
T			14.4			0.567
Ao	4.70	4.80	4.90	0.185	0.189	0.193
Bo	4.30	4.40	4.50	0.169	0.173	0.177
Ko	1.70	1.80	1.90	0.067	0.071	0.075
Po	3.9	4.0	4.1	0.153	0.157	0.161
P	7.9	8.0	8.1	0.311	0.315	0.319

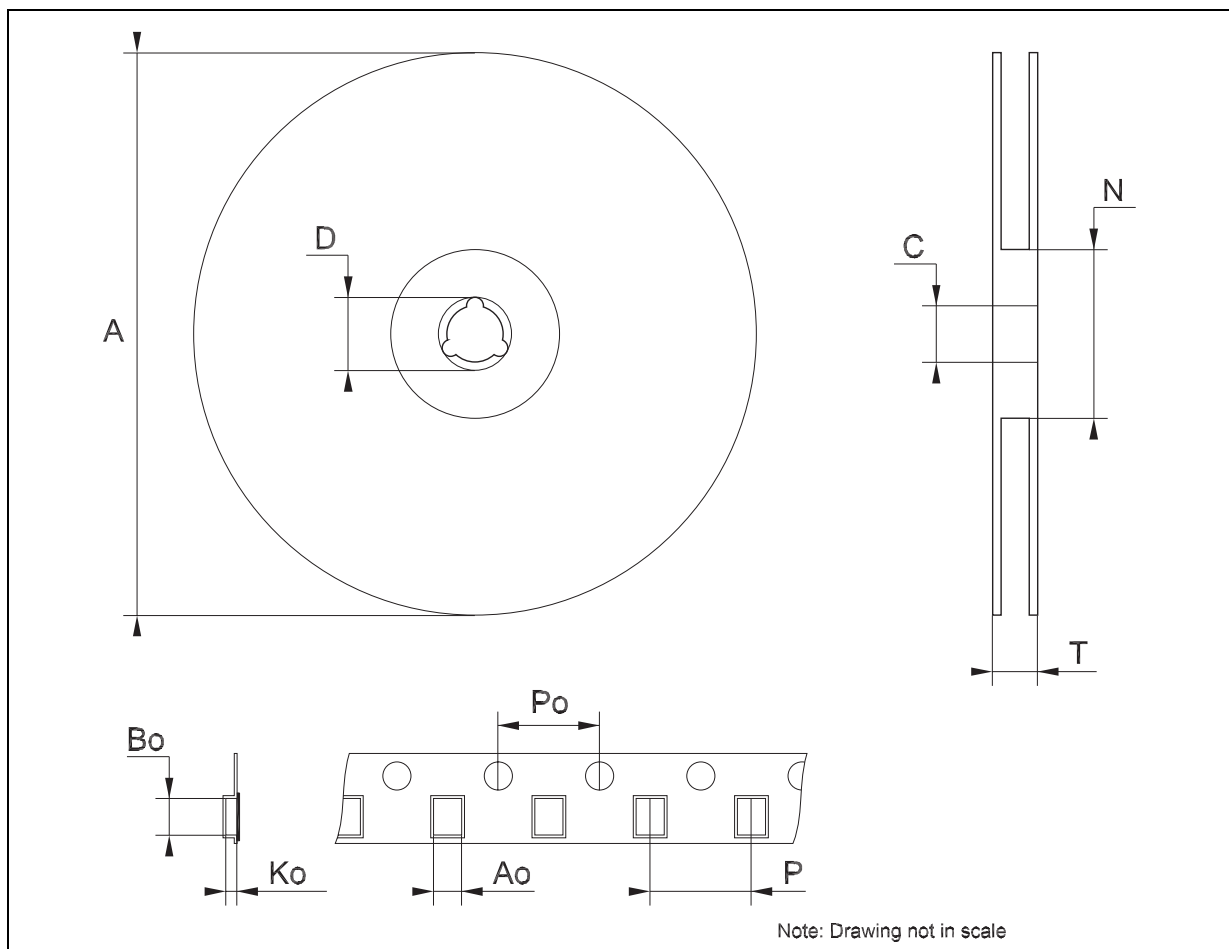

Information furnished is believed to be accurate and reliable. However, STMicroelectronics assumes no responsibility for the consequences of use of such information nor for any infringement of patents or other rights of third parties which may result from its use. No license is granted by implication or otherwise under any patent or patent rights of STMicroelectronics. Specifications mentioned in this publication are subject to change without notice. This publication supersedes and replaces all information previously supplied. STMicroelectronics products are not authorized for use as critical components in life support devices or systems without express written approval of STMicroelectronics.

© The ST logo is a registered trademark of STMicroelectronics

© 2003 STMicroelectronics - Printed in Italy - All Rights Reserved
STMicroelectronics GROUP OF COMPANIES

Australia - Brazil - Canada - China - Finland - France - Germany - Hong Kong - India - Israel - Italy - Japan - Malaysia - Malta - Morocco
Singapore - Spain - Sweden - Switzerland - United Kingdom - United States.

© <http://www.st.com>