



CAR ALTERNATOR VOLTAGE REGULATOR

PRODUCT PREVIEW

- FULLY MONOLITHIC DESIGN
- LOW SIDE FIELD DRIVER
- THERMAL PROTECTION
- FIELD SHORT CIRCUIT PROTECTION
- PROTECTED DIAGNOSTIC LAMP DRIVER
- PROTECTED HIGH SIDE RELAY DRIVER
- COMPLEX DIAGNOSTICS
- LOAD RESPONSE CONTROL
- DFM OUTPUT (FIELD MONITOR)

DESCRIPTION

The L9407F is a monolithic multifunction alternator voltage regulator intended for use in automotive application. It includes the control section, the field power stage, fault diagnostic circuit which drives a warning lamp, and the protection against short circuits.

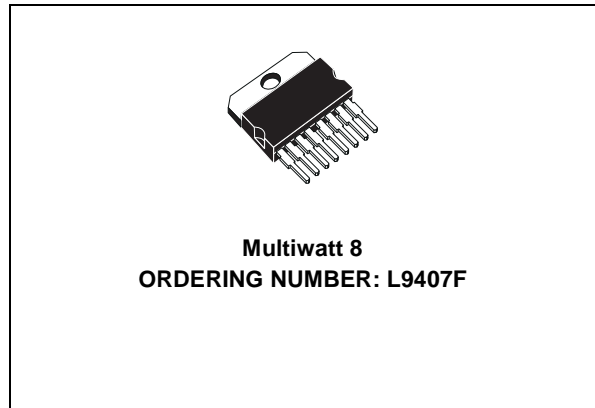
CIRCUIT OPERATION

The alternator's voltage regulator performs the following main functions:

- 1) voltage regulation
- 2) protection
- 3) control fault diagnosis
- 4) load response control

VOLTAGE REGULATION

The alternator voltage is compared with a reference voltage in an amplifier, whose output determines the switching frequency of output power MOS whose current excites the coil of the alternator; as the regulators are a self-oscillating type this frequency depends on the whole system parameter set including the alternator characteristics. The regulators have an integrated filter in the voltage sensing path guaranteeing the correct behaviour of the devices also when the rectifier diodes feature very high switching spikes. The internal filtering allows the usage of the



device also with very long cables connecting the alternator to the battery with an impedance so high to cause a superimposed ripple on the alternator voltage higher than 5-6V. Consequently it doesn't need, in the standard application, any external component. Anyway an external application (2.2uF or 2.7uF) must be inserted between A+ and ground when using the device with very long cables.

PROTECTION

It is present a protection against short circuits of the lamp and the relay power drivers (D+) and of the field power driver (DF), a thermal drivers shutdown protection and an overvoltage protection of D+ power drivers.

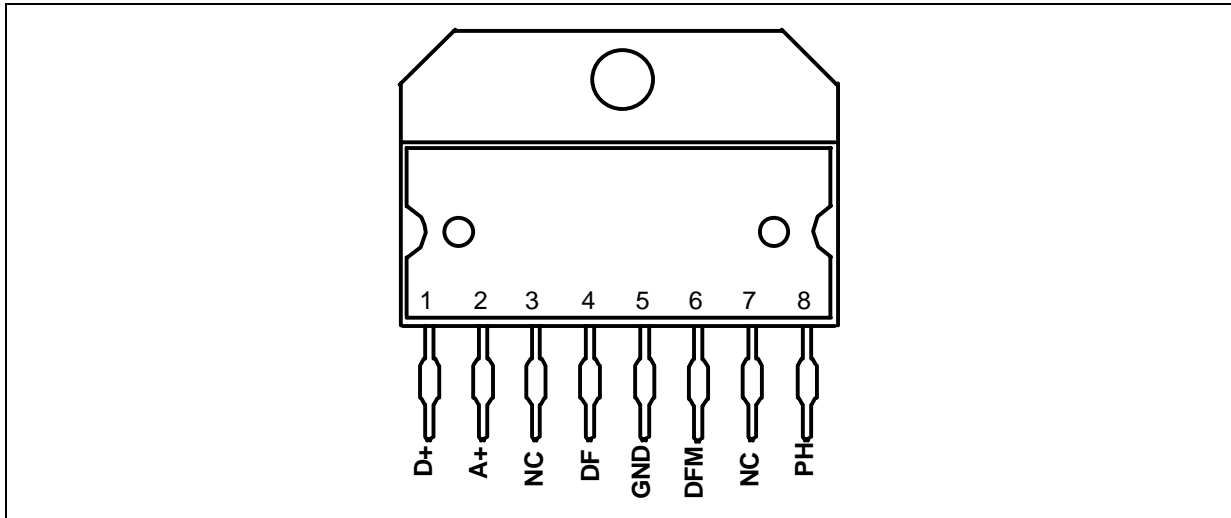
DIAGNOSIS

The circuit detects fault conditions related to the phase and DF status and receives informations from one of the three alternator phases. In order to prevent spurious indications, fault warnings are not displayed immediately but are delayed by a fixed time.

LOAD RESPONSE CONTROL

The internal circuit regulates the soft start characteristics (activated always at engine start) and the soft attack characteristics.

PIN CONNECTION



PIN DESCRIPTION

N°	Pin	Function
1	D+	Lamp terminal low side driver; relay terminal high side driver
2	A+	Alternator output voltage supply
3	NC	Not connected
4	DF	Field low side driver output
5	GND	Ground
6	DFM	Field monitor output
7	NC	Not connected
8	PH	Phase sense input

ABSOLUTE MAXIMUM RATINGS

Symbol	Parameter	Value	Unit
V_S	DC Supply Voltage (2 min. @ 25°C) [all pins vs. GND]	24	V
	Transient Supply Voltage (load dump) [see application circuit] $t < 500ms$	40	V
	Transient Supply Voltage (low energy spikes) [see application circuit] ISO7637-1 pulse 1,2,3 /ISO7637-3	100 (clamped at 60 by application)	V
T_j	Junction temperature range	-40 to 170	°C
T_{stg}, T_{case}	Storage and case temperature range	-40 to 150	°C
P_{tot}	Total power Dissipation (@ $T_{case} = 150°C, I_{field} = 5A$)	8	W
	Reverse Voltage (see application diagram) @ 25°C, $T = 15 sec$ all pins, except for PH (normal working condition)	-2.5	V
	DC Pin Current on DF, A+, GND (bonding limitation)	15	A
	ESD Voltage MILSTD883C (All pins vs.GND)	±4	KV

THERMAL DATA

Symbol	Parameter	Value	Unit
R _{th j-case}	Thermal Resistance Junction to Case	0.6	°C/W

ELECTRICAL CHARACTERISTICS(T_{case} = -40°C ÷ 150°C; unless otherwise specified)

Symbol	Parameter	Test Condition	Min.	Typ.	Max	Unit
V _{bat}	Operating Supply Voltage		6		18	V
I _{b-sinked}	Supply Battery Current				50	mA
I _{b-stby}	Stand-by Current	V _{bat} = A+, DF = 12.5V			500	µA
V _{reg}	Regulated Volt. & Therm. Drift	I _{alt} =1A-0.9*I _{nom} ; T _{case} =20°C; 1200<rpm<RPM _{MAX} ; V _{reg} clamped at 14.8V Max. (Fig.3)	13.9 -4.5	14.35 -3.5	14.8 -2.5	V mV/°C
f _{sw}	Switching Frequency	preexcitation	30		400	Hz
	Delta V _{rpm}	1500<rpm<RPM _{MAX} ; I _{alt} =5A; T _{case} =23°C			200	mV
	Delta V _{load}	5A<I _{alt} <I _{nom} ; rpm=6000rpm; T _{case} =23°C			250	mV
V _{reg}	Reg. Voltage without Battery	I _{alt} = 3A resistive; T _{case} =25°; 2000<rpm<RPM _{MAX}	12		16	V
V _{ov}	D+ Drivers Disable Threshold	Voltage on pin A+ to have D+ OFF	18		22	V
T _{j-sd}	Thermal Shut-down	D+/DF = OFF STATE	180	200	220	°C
T _{j-sd-hys}	Thermal Shut-down hysteresis	D+/DF from OFF STATE (due to thermal shutdown) to ON STATE	T _{j-sd} -2		T _{j-sd} +10	°C
V _{uv}	Low voltage detection threshold	D+ low side driver ON after diagnosis delay time	7.7	8.6	9.5	V
V _{uv-hys}	Low voltage detection threshold hysteresis	D+ low side driver OFF without delay	V _{uv} + 0.40	V _{uv} + 0.50	V _{uv} + 0.60	V
R _{on LSD}	Low Side Driver R _{dson}	T = 150°C; I = 4.5A			189	mΩ
R _{on LSD}	Low Side Driver R _{dson}	T = 25°C; I = 7A			107	mOhm
V _f	Freewheeling diode DF	I=5A			2	V
I _{f_SCTH}	Short Circuit Threshold DF	DF = 12V; T _{case} = -40°C	11		18	A
		DF = 12V; T _{case} = -25°C	8.5		18	A
		DF = 12V; T _{case} = -150°C	5.5		18	A
V _{s1}	Output Short to GROUND DF Threshold		2.1		3.9	V
FS _{duty}	Pre-excitation F.S.D.F.	f = 333Hz +/- 15%	15.93	18.75	21.57	%

ELECTRICAL CHARACTERISTICS (continued)(T_{case} = -40°C ÷ 150°C; unless otherwise specified)

Symbol	Parameter	Test Condition	Min.	Typ.	Max	Unit
t _{ST}	Soft Start Delay Time (see fig. 5)	activated always at engine start		0		s
t _{SL}	Soft Attack Time / Soft Start Time (see fig. 5)	from 0 to 100% field duty cycle	2.45	3	3.45	s
BI	Soft Attack Blind Zone	percentage of maximum duty cycle immediate variation at soft attack	0		10	%
t _{rise}	Output Voltage Rise Time	I _{field} = 3A resistive (Fig. 6)	4		50	μs
t _{fall}	Output Voltage Fall Time	I _{field} = 3A resistive (Fig. 6)	5		50	μs
I _{f_leak}	Output Field Driver Leakage Current	DF = 24V			1	mA
VH _{SAT}	High Side Driver Saturation Voltage (Fig. 9)	I _{source} = 1A			1.2	V
VL _{SAT1}	Low Side Driver Saturation Voltage	I _{sink} = 0.5A			2	V
VL _{SAT2}	Low Side Driver Saturation Voltage	I _{sink} = 0.3A			1.5	V
VLSB	Selfbias without supply Lamp driver Voltage				4	V
I _{HSC}	High Side Driver short circuit current (Fig. 9)	A+ = 17.5V; D+ = GND	1.2		3	A
I _{LSC}	Low Side Driver short circuit current	A+ = D+ = 17.5V	0.7		2.5	A
V _{thD+}	Enable Regulator Voltage D+		0.5	0.7	0.9	V
I _{thD+}	Enable Regulator pull-down Current D+		0.4		3.5	mA
L-t-D	Lamp on delay at Ign. switch turn on	(Fig. 7)			2	ms
V _{can}	Test mode to cancel soft start/attack (voltage)	(Fig. 8)	36		44	V
V _{PHL1}	Enable control voltage input high threshold	square wave f = 1KHz	0.67	0.795	0.92	V
t _{PH}	PH Filtering Time		50		200	μs
V _{PHH1}	Diagnosis phase loss input high threshold		9	10.25	11.5	V
V _{PHH2}	Diagnosis phase loss input low threshold	guaranteed by design	4	5	6	V
t _{PHd}	Diagnostic PH Filtering Time	guaranteed by design	50		200	μs
I _{L_Th-PH}	Phase Pull-down Current		1		8	mA

ELECTRICAL CHARACTERISTICS (continued)(T_{case} = -40°C ÷ 150°C; unless otherwise specified)

Symbol	Parameter	Test Condition	Min.	Typ.	Max	Unit
EN	Soft start enable frequency range	T _{case} = 25°C T _{case} = -40 to 150°C	144 136	160 160	176 184	Hz Hz
f_RESS_SS	Reset frequency range to enable soft start		40	50	60	Hz
DISAB	Soft start enable frequency range	T _{case} = 25°C T _{case} = -40 to 150°C	367 347	408 408	449 469	Hz Hz
f-dfm	Output open drain switching freq.	preexc. mode; I _{sink} =14mA	30		400	Hz
VL-DF-MON	Output low voltage saturation	I _{sink} =14mA			1.5	V
I-DF-MON	Short circuit current protection	V-DF-MON=24V field fully on	15		120	mA
I _{lk} -DF-MON	Output leakage current	V-DF-MON=24V field off			0.1	mA
t-TM	Output voltage rise time	R=2.7K Ohm; C=1nF; Valim=13.5V (Fig. 6)	0.05		50	us
t-TD	Output voltage fall time	R=2.7K Ohm; C=1nF; Valim=13.5V (Fig. 6)	0.05		50	us
t-D	Diagnostic Alarm Delay Time		0.15		0.5	s

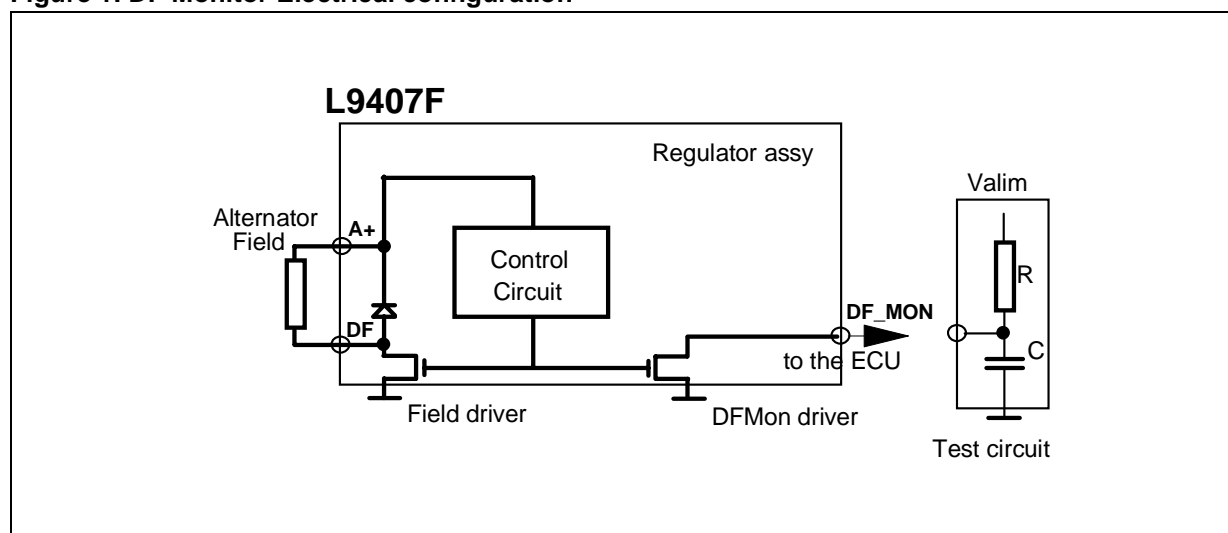
Figure 1. DF Monitor Electrical configuration

Figure 2. Application Diagram

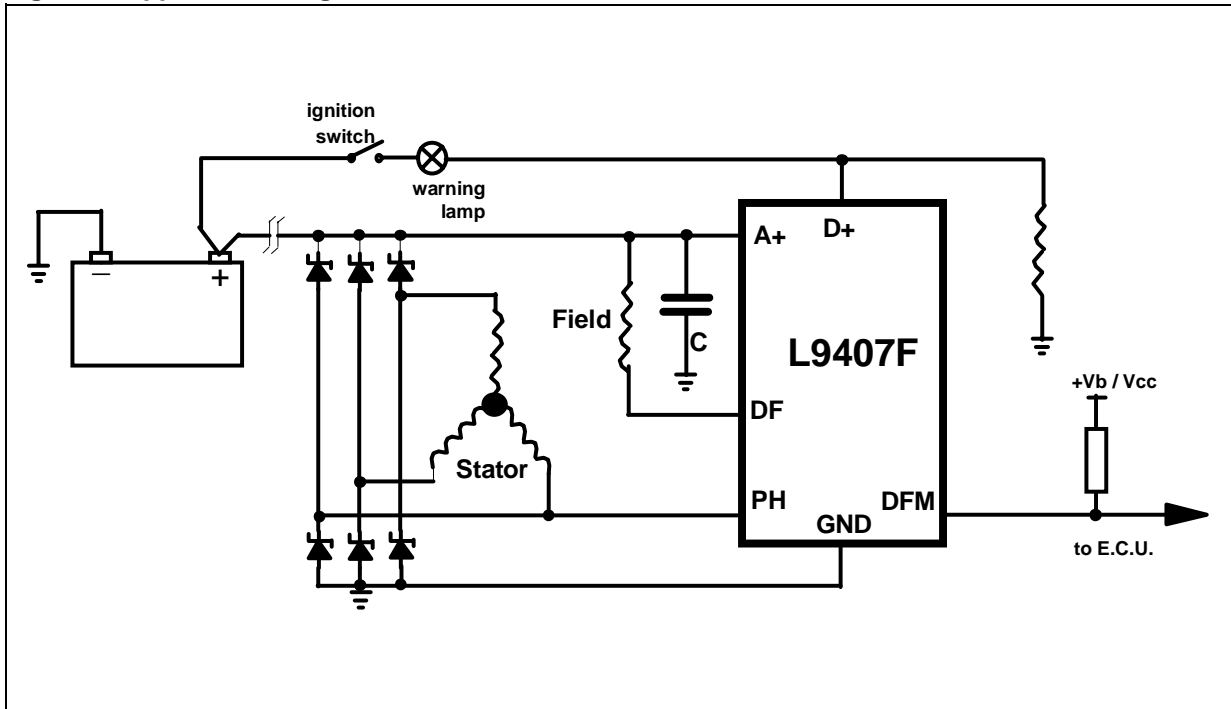


Figure 3. L9407F THERMAL COMPENSATION (Vreg.)

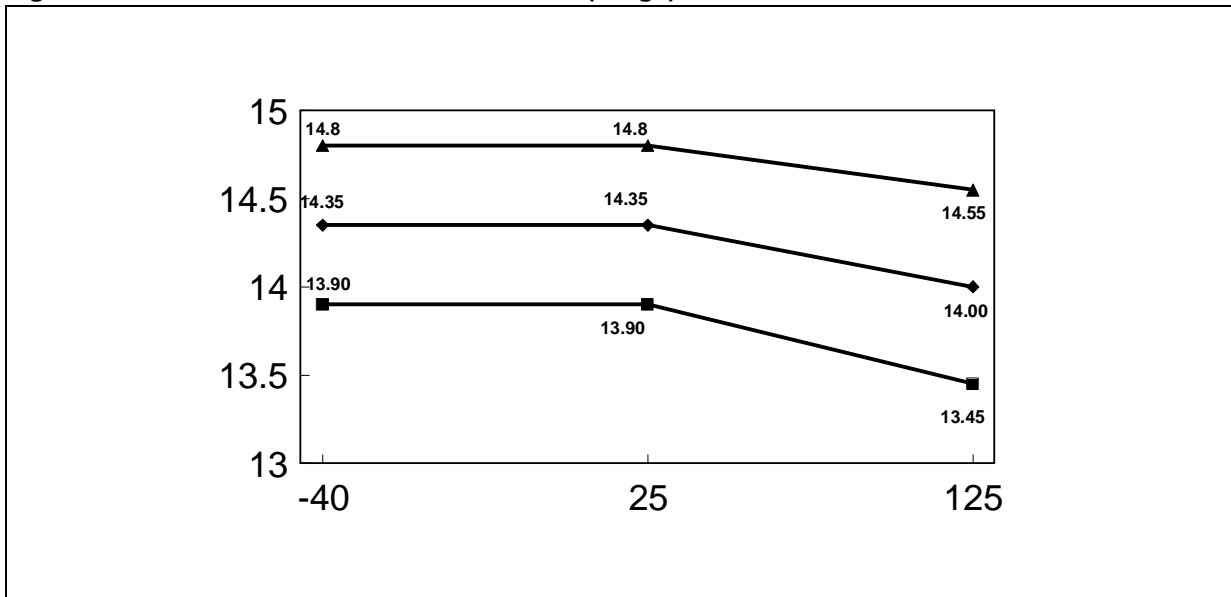


Figure 4. Characteristics (Active always at engine start)

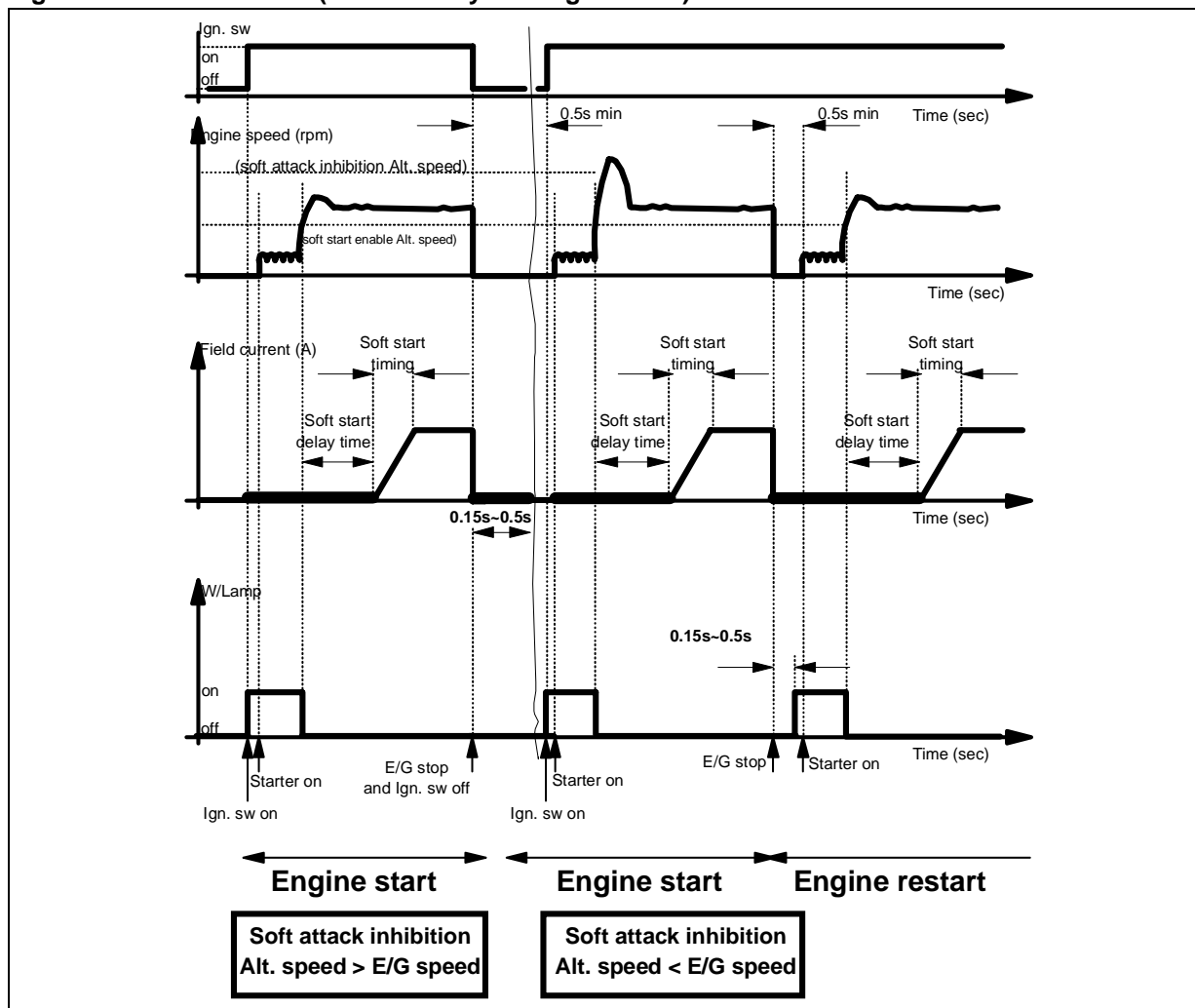


Figure 5. Soft Start/attack Characteristics

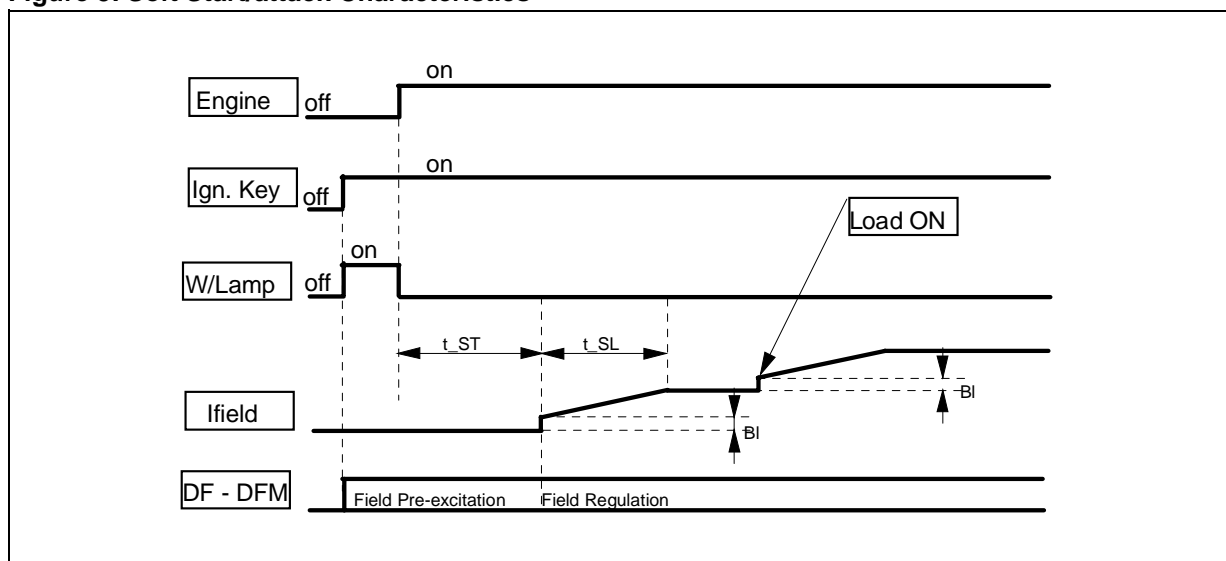


Table 1. FAULT DETECTION TABLE

Root Cause	Signal	Effect	Test detect
Alternator belt breaking	PH	Alternator disexcitation	$V_{PH} < V_{PHH} \ \& \ V_{A+} < V_{reg}$
Brushes open	PH	Alternator disexcitation	$V_{PH} < V_{PHH} \ \& \ V_{A+} < V_{reg}$
Driver Open	PH	Alternator disexcitation	$V_{PH} < V_{PHH} \ \& \ V_{A+} < V_{reg}$
Field interruption	PH	Alternator disexcitation	$V_{PH} < V_{PHH} \ \& \ V_{A+} < V_{reg}$
Field short circuit to the battery	PH	Alternator disexcitation	$V_{PH} < V_{PHH} \ \& \ V_{A+} < V_{reg}$
Field short circuit to the ground	DF	Overvoltage	$DF < VS1 \ \& \ V_{A+} > V_{reg}$
Battery discharge (Field Driver open)	A+	Undervoltage	$V_{A+} < V_{reg}$
No fully excited	A+	Undervoltage	$V_{A+} < V_{uv}$
Battery discharge	A+	Undervoltage	$V_{A+} < V_{uv}$

The diagnostic result is disabled during the Soft-start delay time t_{ST} and the soft-start / soft attack timing t_{SL}

Figure 6. Output Voltage rise/fall time (DF, DF_MON)

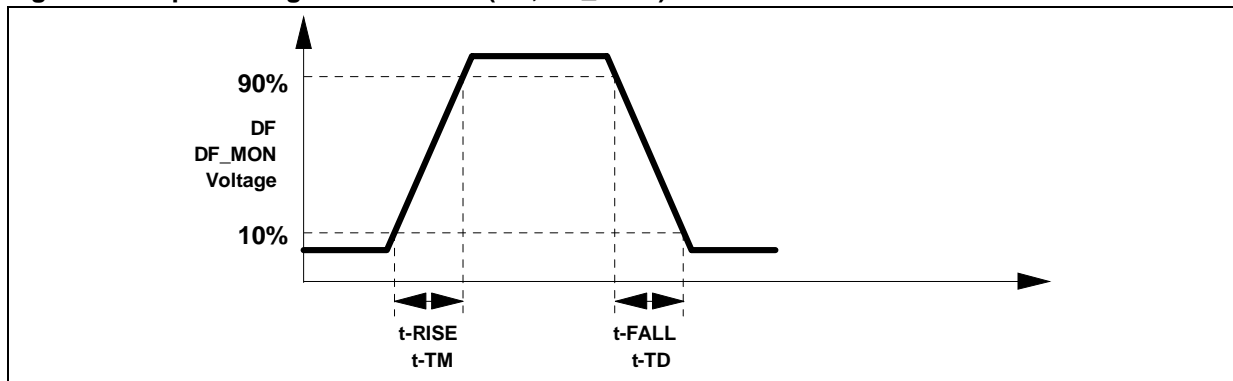


Figure 7. Lamp on delay at Ign. switch turn on

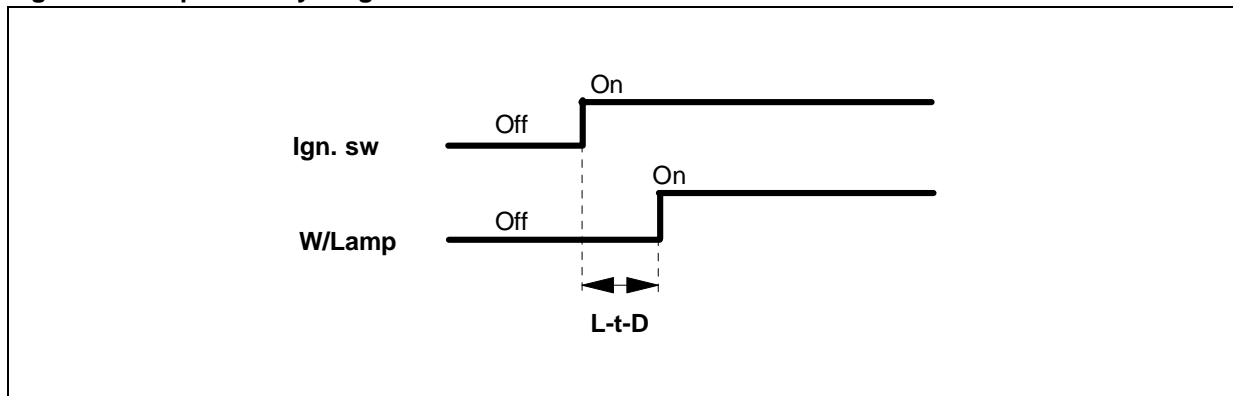


Figure 8. Test mode to cancel soft start/attack

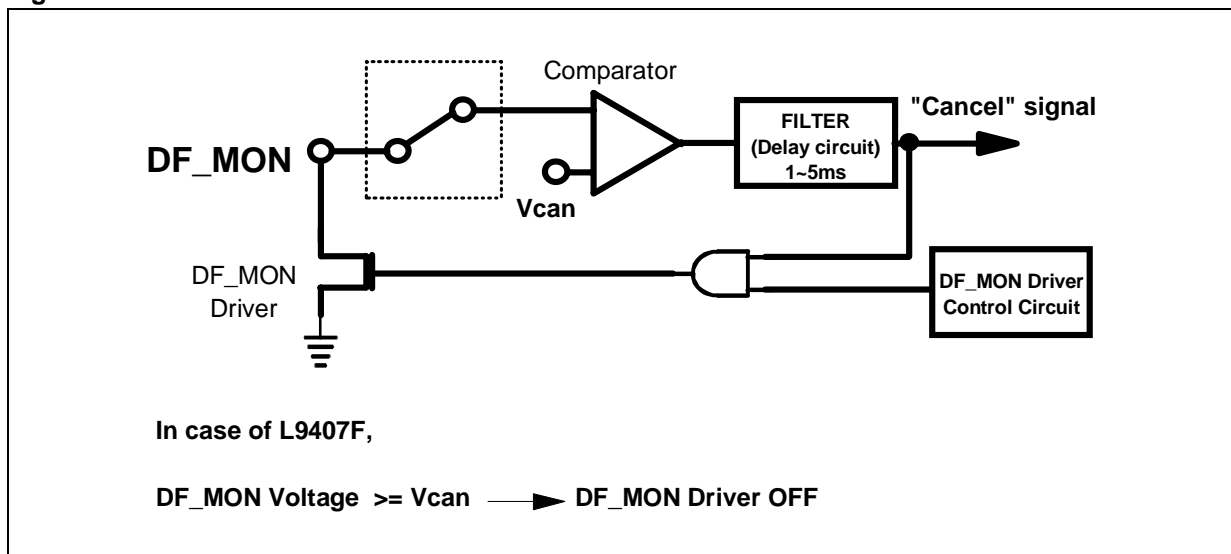
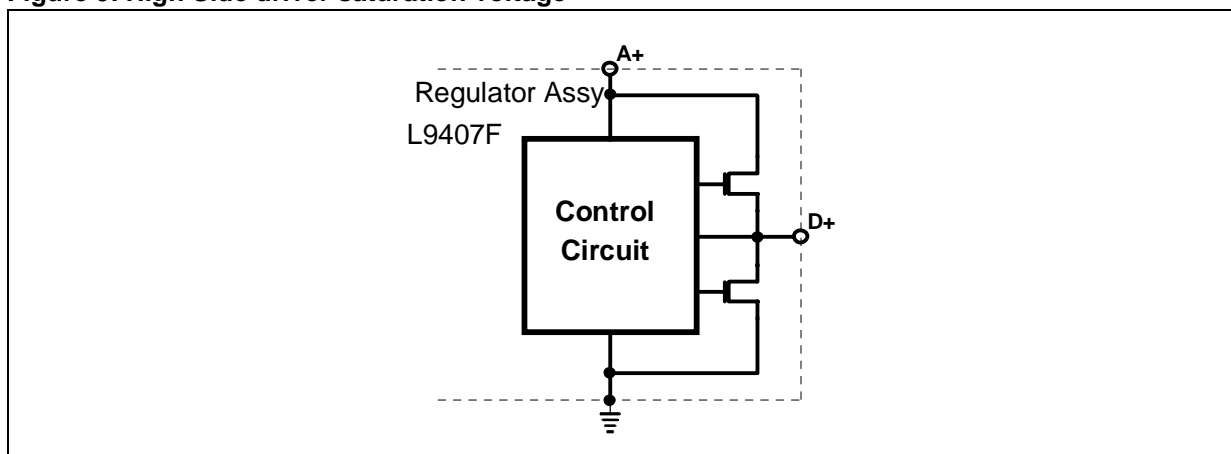


Figure 9. High Side driver saturation voltage

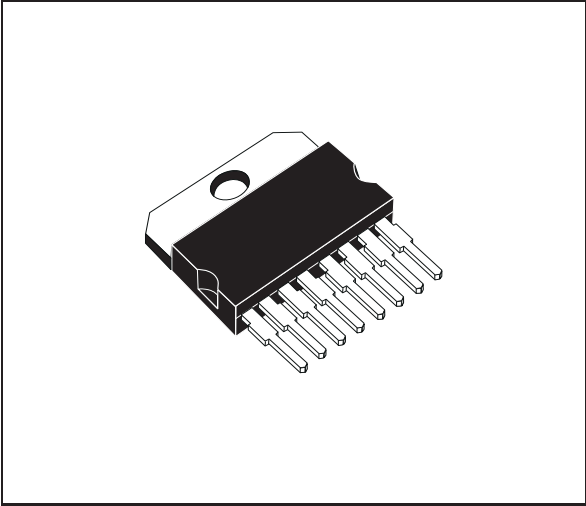


L9407F

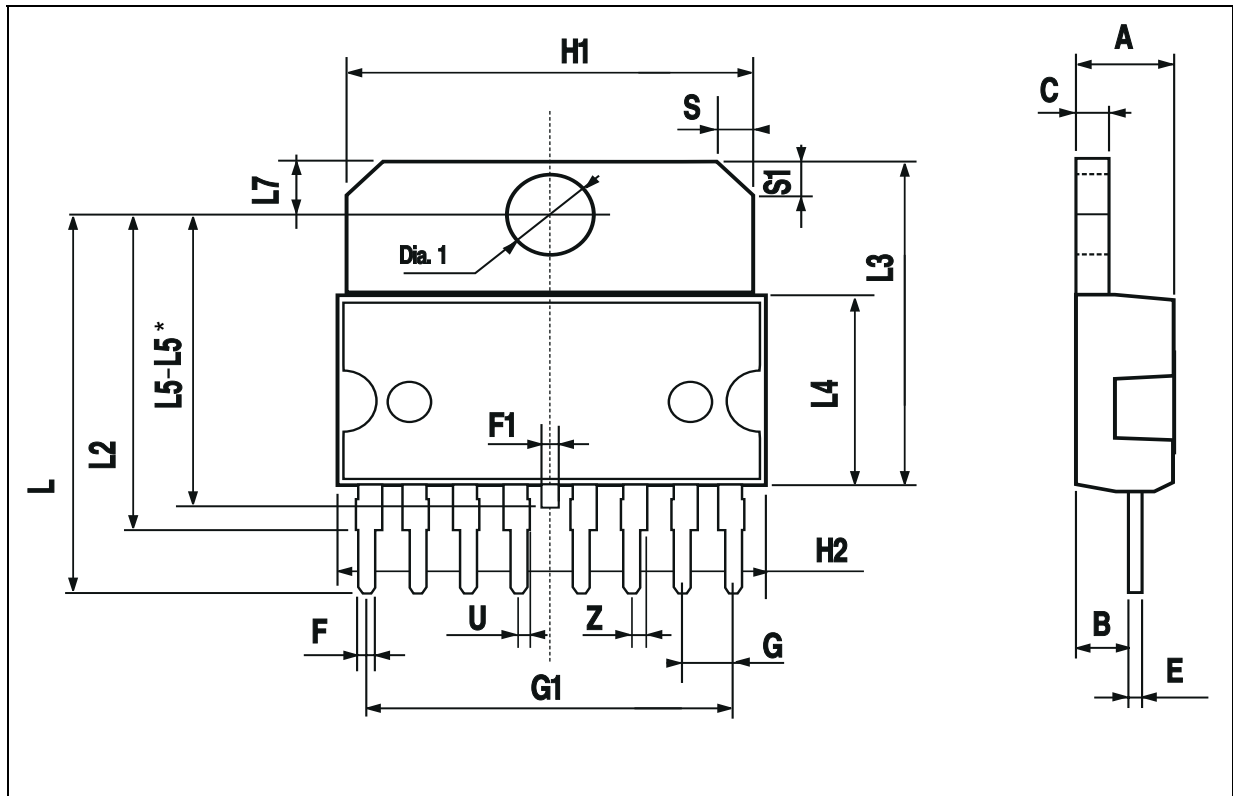
DIM.	mm			inch		
	MIN.	TYP.	MAX.	MIN.	TYP.	MAX.
A			5			0.197
B			2.65			0.104
C			1.6			0.063
E	0.49		0.55	0.019		0.022
F	0.78		0.85	0.030		0.033
F1	0.68		0.75	0.027		0.029
G	2.40	2.54	2.68	0.094	0.10	0.105
G1	17.64	17.78	17.92	0.69	0.70	0.71
H1	19.6			0.772		
H2			20.2			0.795
L	20.35		20.65	0.80		0.81
L2	17.05	17.20	17.35	0.67	0.68	0.68
L3	17.25	17.5	17.75	0.679	0.689	0.699
L4	10.3	10.7	10.9	0.406	0.421	0.429
L5	15.45		15.75	0.61		0.62
L5*	15.05		15.35	0.59		0.60
L7	2.65		2.9	0.104		0.114
S	1.9		2.6	0.075		0.102
S1	1.9		2.6	0.075		0.102
U	0.40		0.55	0.015		0.022
Z	0.70		0.85	0.028		0.034
Dia1	3.65		3.85	0.144		0.152

L5 = with wedged frame std.
 L5* = with wedged frame anchor holes.

OUTLINE AND MECHANICAL DATA



Multiwatt8 (Floating)



Information furnished is believed to be accurate and reliable. However, STMicroelectronics assumes no responsibility for the consequences of use of such information nor for any infringement of patents or other rights of third parties which may result from its use. No license is granted by implication or otherwise under any patent or patent rights of STMicroelectronics. Specifications mentioned in this publication are subject to change without notice. This publication supersedes and replaces all information previously supplied. STMicroelectronics products are not authorized for use as critical components in life support devices or systems without express written approval of STMicroelectronics.

STMicroelectronics acknowledges the trademarks of all companies referred to in this document.

The ST logo is a registered trademark of STMicroelectronics
© 2003 STMicroelectronics - All Rights Reserved

STMicroelectronics GROUP OF COMPANIES

Australia - Brazil - Canada - China - Finland - France - Germany - Hong Kong - India - Israel - Italy - Japan - Malaysia - Malta - Morocco -
Singapore - Spain - Sweden - Switzerland - United Kingdom - United States.

<http://www.st.com>