



# LD1084 SERIES

## 5A LOW DROP POSITIVE VOLTAGE REGULATOR ADJUSTABLE AND FIXED

- TYPICAL DROPOUT 1.3V (AT 5A)
- THREE TERMINAL ADJUSTABLE OR FIXED OUTPUT VOLTAGE 1.5, 1.8V, 2.5V, 2.85V, 3.3V, 3.6V, 5V, 8V, 9V, 12V.
- GUARANTEED OUTPUT CURRENT UP TO 5A
- OUTPUT TOLERANCE  $\pm 1\%$  AT 25°C AND  $\pm 2\%$  IN FULL TEMPERATURE RANGE
- INTERNAL POWER AND THERMAL LIMIT
- WIDE OPERATING TEMPERATURE RANGE -40°C TO 125°C
- PACKAGE AVAILABLE : TO-220, D<sup>2</sup>PAK, D<sup>2</sup>PAK/A
- PINOUT COMPATIBILITY WITH STANDARD ADJUSTABLE VREG

### DESCRIPTION

The LD1084 is a LOW DROP Voltage Regulator able to provide up to 5A of Output Current. Dropout is guaranteed at a maximum of 1.5V at the maximum output current, decreasing at lower loads. The LD1084 is pin to pin compatible with the older 3-terminal adjustable regulators, but has better performances in term of drop and output tolerance .

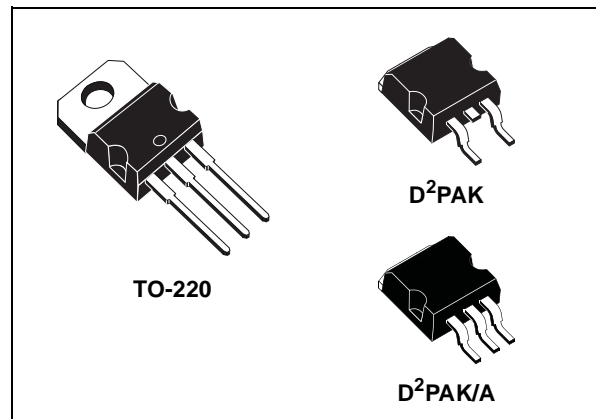

A 2.85V output version is suitable for SCSI-2 active termination. Unlike PNP regulators, where a part of the output current is wasted as quiescent current, the LD1084 quiescent current flows into the load, so increase efficiency. Only a 10 $\mu$ F minimum capacitor is need for stability. The device is supplied in TO-220, D<sup>2</sup>PAK and D<sup>2</sup>PAK/A. On chip trimming allows the regulator to reach a very tight output voltage tolerance, within  $\pm 1\%$  at 25°C.

### SCHEMATIC DIAGRAM

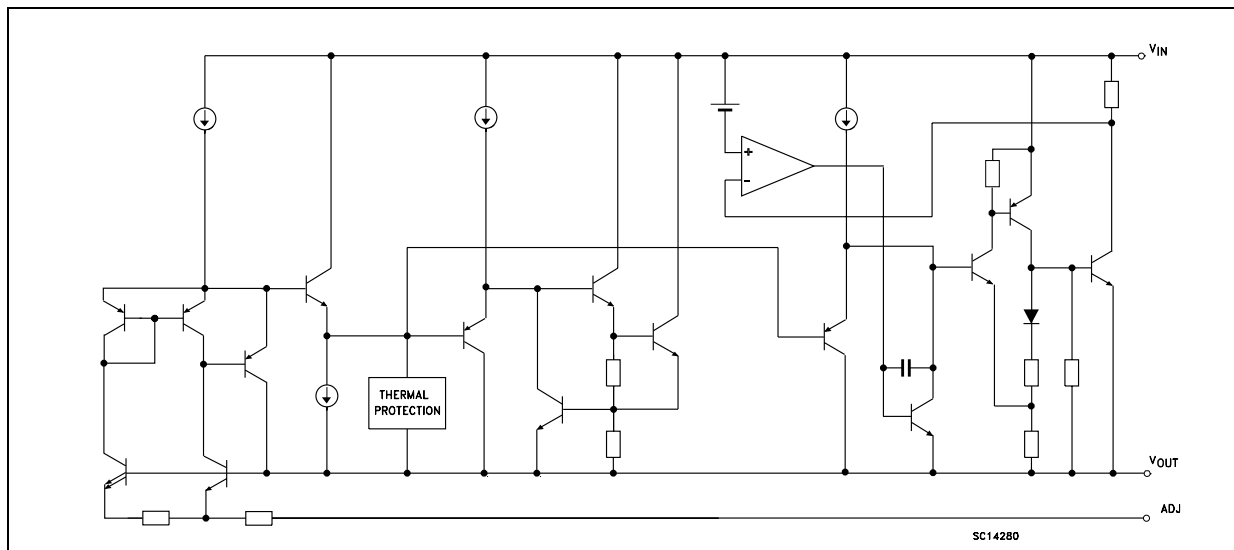

# LD1084 SERIES

## ABSOLUTE MAXIMUM RATINGS

Symbol	Parameter <sup>2</sup>	Value	Unit
V <sub>I</sub>	DC Input Voltage	30	V
I <sub>O</sub>	Output Current	Internally Limited	mA
P <sub>D</sub>	Power Dissipation	Internally Limited	mW
T <sub>stg</sub>	Storage Temperature Range	-55 to +150	°C
T <sub>op</sub>	Operating Junction Temperature Range	-40 to +125	°C

Absolute Maximum Ratings are those values beyond which damage to the device may occur. Functional operation under these condition is not implied.

## THERMAL DATA

Symbol	Parameter	TO-220	D <sup>2</sup> PAK	Unit
R <sub>thj-case</sub>	Thermal Resistance Junction-case	3	3	°C/W
R <sub>thj-amb</sub>	Thermal Resistance Junction-ambient	50	62.5	°C/W

## APPLICATION CIRCUITS

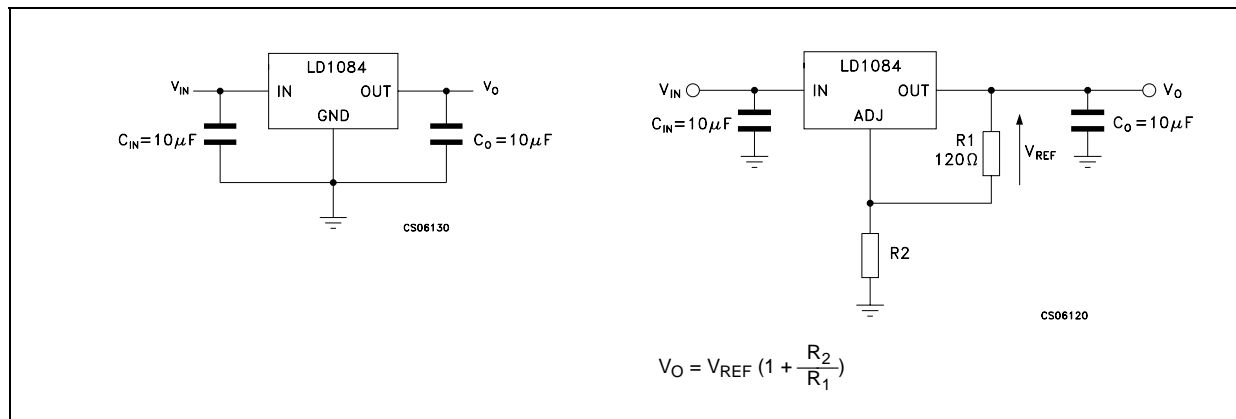

## CONNECTION DIAGRAM (top view)

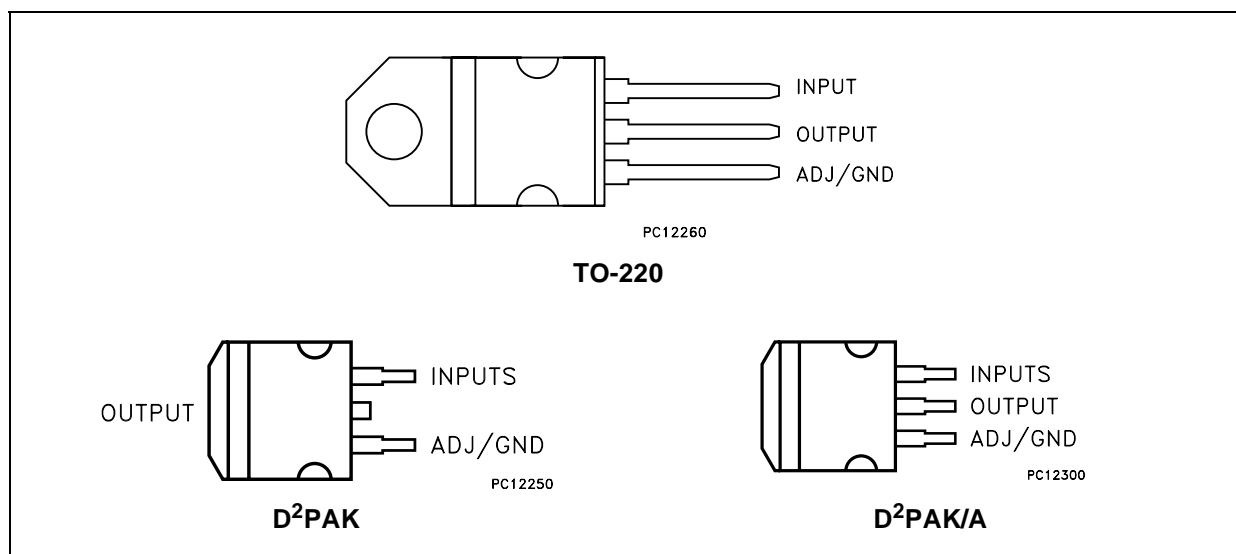

## ORDERING CODES

TYPE	D <sup>2</sup> PAK (*)	D <sup>2</sup> PAK/A	OUTPUT VOLTAGE
LD1084V15	LD1084D2T15	LD1084D2M15	1.5 V
LD1084V18	LD1084D2T18	LD1084D2M18	1.8 V
LD1084V25	LD1084D2T25	LD1084D2M25	2.5 V
LD1084V28	LD1084D2T28	LD1084D2M28	2.85 V
LD1084V33	LD1084D2T33	LD1084D2M33	3.3 V
LD1084V36	LD1084D2T36	LD1084D2M36	3.6 V
LD1084V50	LD1084D2T50	LD1084D2M50	5.0 V
LD1084V80	LD1084D2T80	LD1084D2M80	8.0 V
LD1084V90	LD1084D2T90	LD1084D2M90	9.0 V
LD1084V120	LD1084D2T120	LD1084D2M120	12.0 V
LD1084V	LD1084D2T	LD1084D2M	ADJ

(\*) Available in Tape & Reel with the suffix "R" for fixed versions and "-R" for adjustable version

**ELECTRICAL CHARACTERISTICS OF LD1084#15** ( $V_I=4.5V$ ,  $C_I = C_O = 10\mu F$ ,  $T_A = -40$  to  $125^\circ C$ , unless otherwise specified.)

Symbol	Parameter	Test Conditions	Min.	Typ.	Max.	Unit
$V_O$	Output Voltage	$I_O = 0$ mA $T_J = 25^\circ C$	1.485	1.5	1.515	V
		$I_O = 0$ to 5A $V_I = 3.1$ to 30V (note 1)	1.47	1.5	1.53	V
$\Delta V_O$	Line Regulation	$I_O = 0$ mA $V_I = 3.1$ to 18V $T_J = 25^\circ C$		0.5	6	mV
		$I_O = 0$ mA $V_I = 3.1$ to 15V		0.1	6	mV
$\Delta V_O$	Load Regulation	$I_O = 0$ to 5A $T_J = 25^\circ C$		3	15	mV
		$I_O = 0$ to 5A		7	20	V
$V_d$	Dropout Voltage	$I_O = 5$ A		1.3	1.5	V
$I_q$	Quiescent Current	$V_I \leq 30V$		5	10	mA
$I_{sc}$	Short Circuit Current	$V_I - V_O = 5V$	5.5	6.5		A
		$V_I - V_O = 25V$	0.5	0.7		A
	Thermal Regulation	$T_A = 25^\circ C$ , 30ms pulse		0.003	0.015	%/W
SVR	Supply Voltage Rejection	$f = 120$ Hz, $C_O = 25 \mu F$ , $I_O = 5A$ $V_I = 6.8 \pm 3V$	60	75		dB
eN	RMS Output Noise Voltage (% of $V_O$ )	$T_A = 25^\circ C$ $f = 10Hz$ to $10KHz$		0.003		%
S	Temperature Stability			0.5		%
S	Long Term Stability	$T_A = 125^\circ C$ 1000Hrs		0.5		%

NOTE 1: See short-circuit current curve for available output current at fixed dropout.

## LD1084 SERIES

**ELECTRICAL CHARACTERISTICS OF LD1084#18** ( $V_I=4.8V$ ,  $C_I = C_O=10\mu F$ ,  $T_A = -40$  to  $125^\circ C$ , unless otherwise specified.)

Symbol	Parameter	Test Conditions	Min.	Typ.	Max.	Unit
$V_O$	Output Voltage	$I_O = 0 \text{ mA}$ $T_J = 25^\circ C$	1.782	1.8	1.818	V
		$I_O = 0$ to $5A$ $V_I = 3.4$ to $30V$ (note 1)	1.764	1.8	1.836	V
$\Delta V_O$	Line Regulation	$I_O = 0 \text{ mA}$ $V_I = 3.4$ to $18V$ $T_J = 25^\circ C$		0.5	6	mV
		$I_O = 0 \text{ mA}$ $V_I = 3.4$ to $15V$		0.1	6	mV
$\Delta V_O$	Load Regulation	$I_O = 0$ to $5A$ $T_J = 25^\circ C$		3	15	mV
		$I_O = 0$ to $5A$		7	20	V
$V_d$	Dropout Voltage	$I_O = 5 \text{ A}$		1.3	1.5	V
$I_q$	Quiescent Current	$V_I \leq 30V$		5	10	mA
$I_{sc}$	Short Circuit Current	$V_I - V_O = 5V$	5.5	6.5		A
		$V_I - V_O = 25V$	0.5	0.7		A
	Thermal Regulation	$T_A = 25^\circ C$ , 30ms pulse		0.003	0.015	%/W
SVR	Supply Voltage Rejection	$f = 120 \text{ Hz}$ , $C_O = 25 \mu F$ , $I_O = 5A$ $V_I = 6.8 \pm 3V$	60	75		dB
eN	RMS Output Noise Voltage (% of $V_O$ )	$T_A = 25^\circ C$ $f = 10\text{Hz}$ to $10\text{KHz}$		0.003		%
S	Temperature Stability			0.5		%
S	Long Term Stability	$T_A = 125^\circ C$ 1000Hrs		0.5		%

NOTE 1: See short-circuit current curve for available output current at fixed dropout.

**ELECTRICAL CHARACTERISTICS OF LD1084#25** ( $V_I=5.5V$ ,  $C_I = C_O=10\mu F$ ,  $T_A = -40$  to  $125^\circ C$ , unless otherwise specified.)

Symbol	Parameter	Test Conditions	Min.	Typ.	Max.	Unit
$V_O$	Output Voltage	$I_O = 0 \text{ mA}$ $T_J = 25^\circ C$	2.475	2.5	2.525	V
		$I_O = 0$ to $5A$ $V_I = 4.1$ to $30V$ (note 1)	2.45	2.5	2.55	V
$\Delta V_O$	Line Regulation	$I_O = 0 \text{ mA}$ $V_I = 4.1$ to $18V$ $T_J = 25^\circ C$		0.5	6	mV
		$I_O = 0 \text{ mA}$ $V_I = 4.1$ to $18V$		0.1	6	mV
$\Delta V_O$	Load Regulation	$I_O = 0$ to $5A$ $T_J = 25^\circ C$		3	15	mV
		$I_O = 0$ to $5A$		7	20	V
$V_d$	Dropout Voltage	$I_O = 5 \text{ A}$		1.3	1.5	V
$I_q$	Quiescent Current	$V_I \leq 30V$		5	10	mA
$I_{sc}$	Short Circuit Current	$V_I - V_O = 5V$	5.5	6.5		A
		$V_I - V_O = 25V$	0.5	0.7		A
	Thermal Regulation	$T_A = 25^\circ C$ , 30ms pulse		0.003	0.015	%/W
SVR	Supply Voltage Rejection	$f = 120 \text{ Hz}$ , $C_O = 25 \mu F$ , $I_O = 5A$ $V_I = 7.5 \pm 3V$	60	72		dB
eN	RMS Output Noise Voltage (% of $V_O$ )	$T_A = 25^\circ C$ $f = 10\text{Hz}$ to $10\text{KHz}$		0.003		%
S	Temperature Stability			0.5		%
S	Long Term Stability	$T_A = 125^\circ C$ 1000Hrs		0.5		%

NOTE 1: See short-circuit current curve for available output current at fixed dropout.

**ELECTRICAL CHARACTERISTICS OF LD1084#285** ( $V_I=5.85V$ ,  $C_I = C_O = 10\mu F$ ,  $T_A = -40$  to  $125^\circ C$ , unless otherwise specified.)

Symbol	Parameter	Test Conditions	Min.	Typ.	Max.	Unit
$V_O$	Output Voltage	$I_O = 0 \text{ mA}$ $T_J = 25^\circ C$	2.821	2.85	2.879	V
		$I_O = 0$ to $5A$ $V_I = 4.5$ to $30V$ (note 1)	2.793	2.85	2.907	V
$\Delta V_O$	Line Regulation	$I_O = 0 \text{ mA}$ $V_I = 4.5$ to $18V$ $T_J = 25^\circ C$		0.5	6	mV
		$I_O = 0 \text{ mA}$ $V_I = 4.5$ to $18V$		0.1	6	mV
$\Delta V_O$	Load Regulation	$I_O = 0$ to $5A$ $T_J = 25^\circ C$		3	15	mV
		$I_O = 0$ to $5A$		7	20	V
$V_d$	Dropout Voltage	$I_O = 5 \text{ A}$		1.3	1.5	V
$I_q$	Quiescent Current	$V_I \leq 30V$		5	10	mA
$I_{sc}$	Short Circuit Current	$V_I - V_O = 5V$	5.5	6.5		A
		$V_I - V_O = 25V$	0.5	0.7		A
	Thermal Regulation	$T_A = 25^\circ C$ , 30ms pulse		0.003	0.015	%/W
SVR	Supply Voltage Rejection	$f = 120 \text{ Hz}$ , $C_O = 25 \mu F$ , $I_O = 5A$ $V_I = 7.85 \pm 3V$	60	72		dB
eN	RMS Output Noise Voltage (% of $V_O$ )	$T_A = 25^\circ C$ $f = 10\text{Hz}$ to $10\text{KHz}$		0.003		%
S	Temperature Stability			0.5		%
S	Long Term Stability	$T_A = 125^\circ C$ 1000Hrs		0.5		%

NOTE 1: See short-circuit current curve for available output current at fixed dropout.

**ELECTRICAL CHARACTERISTICS OF LD1084#33** ( $V_I=6.3V$ ,  $C_I = C_O = 10\mu F$ ,  $T_A = -40$  to  $125^\circ C$ , unless otherwise specified.)

Symbol	Parameter	Test Conditions	Min.	Typ.	Max.	Unit
$V_O$	Output Voltage	$I_O = 0 \text{ mA}$ $T_J = 25^\circ C$	3.267	3.3	3.333	V
		$I_O = 0$ to $5A$ $V_I = 4.9$ to $30V$ (note 1)	3.234	3.35	3.366	V
$\Delta V_O$	Line Regulation	$I_O = 0 \text{ mA}$ $V_I = 4.9$ to $18V$ $T_J = 25^\circ C$		0.5	6	mV
		$I_O = 0 \text{ mA}$ $V_I = 4.9$ to $18V$		0.1	6	mV
$\Delta V_O$	Load Regulation	$I_O = 0$ to $5A$ $T_J = 25^\circ C$		3	15	mV
		$I_O = 0$ to $5A$		7	20	V
$V_d$	Dropout Voltage	$I_O = 5 \text{ A}$		1.3	1.5	V
$I_q$	Quiescent Current	$V_I \leq 30V$		5	10	mA
$I_{sc}$	Short Circuit Current	$V_I - V_O = 5V$	5.5	6.5		A
		$V_I - V_O = 25V$	0.5	0.7		A
	Thermal Regulation	$T_A = 25^\circ C$ , 30ms pulse		0.003	0.015	%/W
SVR	Supply Voltage Rejection	$f = 120 \text{ Hz}$ , $C_O = 25 \mu F$ , $I_O = 5A$ $V_I = 8.3 \pm 3V$	60	72		dB
eN	RMS Output Noise Voltage (% of $V_O$ )	$T_A = 25^\circ C$ $f = 10\text{Hz}$ to $10\text{KHz}$		0.003		%
S	Temperature Stability			0.5		%
S	Long Term Stability	$T_A = 125^\circ C$ 1000Hrs		0.5		%

NOTE 1: See short-circuit current curve for available output current at fixed dropout.

## LD1084 SERIES

**ELECTRICAL CHARACTERISTICS OF LD1084#36** ( $V_I=6.6V$ ,  $C_I = C_O=10\mu F$ ,  $T_A = -40$  to  $125^\circ C$ , unless otherwise specified.)

Symbol	Parameter	Test Conditions	Min.	Typ.	Max.	Unit
$V_O$	Output Voltage	$I_O = 0 \text{ mA}$ $T_J = 25^\circ C$	3.564	3.6	3.636	V
		$I_O = 0$ to $5A$ $V_I = 5.2$ to $30V$ (note 1)	3.528	3.6	3.672	V
$\Delta V_O$	Line Regulation	$I_O = 0 \text{ mA}$ $V_I = 5.2$ to $18V$ $T_J = 25^\circ C$		0.5	10	mV
		$I_O = 0 \text{ mA}$ $V_I = 5.2$ to $18V$		0.1	10	mV
$\Delta V_O$	Load Regulation	$I_O = 0$ to $5A$ $T_J = 25^\circ C$		3	15	mV
		$I_O = 0$ to $5A$		7	20	V
$V_d$	Dropout Voltage	$I_O = 5 \text{ A}$		1.3	1.5	V
$I_q$	Quiescent Current	$V_I \leq 30V$		5	10	mA
$I_{sc}$	Short Circuit Current	$V_I - V_O = 5V$	5.5	6.5		A
		$V_I - V_O = 25V$	0.5	0.7		A
	Thermal Regulation	$T_A = 25^\circ C$ , 30ms pulse		0.003	0.015	%/W
SVR	Supply Voltage Rejection	$f = 120 \text{ Hz}$ , $C_O = 25 \mu F$ , $I_O = 5A$ $V_I = 8.6 \pm 3V$	60	72		dB
eN	RMS Output Noise Voltage (% of $V_O$ )	$T_A = 25^\circ C$ $f = 10\text{Hz}$ to $10\text{KHz}$		0.003		%
S	Temperature Stability			0.5		%
S	Long Term Stability	$T_A = 125^\circ C$ 1000Hrs		0.5		%

NOTE 1: See short-circuit current curve for available output current at fixed dropout.

**ELECTRICAL CHARACTERISTICS OF LD1084#5** ( $V_I=8V$ ,  $C_I = C_O = 10\mu F$ ,  $T_A = -40$  to  $125^\circ C$ , unless otherwise specified.)

Symbol	Parameter	Test Conditions	Min.	Typ.	Max.	Unit
$V_O$	Output Voltage	$I_O = 0 \text{ mA}$ $T_J = 25^\circ C$	4.95	5	5.05	V
		$I_O = 0$ to $5A$ $V_I = 6.6$ to $30V$ (note 1)	4.9	5	5.1	V
$\Delta V_O$	Line Regulation	$I_O = 0 \text{ mA}$ $V_I = 6.6$ to $20V$ $T_J = 25^\circ C$		0.5	10	mV
		$I_O = 0 \text{ mA}$ $V_I = 6.6$ to $20V$		1	10	mV
$\Delta V_O$	Load Regulation	$I_O = 0$ to $5A$ $T_J = 25^\circ C$		5	20	mV
		$I_O = 0$ to $5A$		10	35	V
$V_d$	Dropout Voltage	$I_O = 5 \text{ A}$		1.3	1.5	V
$I_q$	Quiescent Current	$V_I \leq 30V$		5	10	mA
$I_{sc}$	Short Circuit Current	$V_I - V_O = 5V$	5.5	6.5		A
		$V_I - V_O = 25V$	0.5	0.7		A
	Thermal Regulation	$T_A = 25^\circ C$ , 30ms pulse		0.003	0.015	%/W
SVR	Supply Voltage Rejection	$f = 120 \text{ Hz}$ , $C_O = 25 \mu F$ , $I_O = 5A$ $V_I = 10 \pm 3V$	60	72		dB
eN	RMS Output Noise Voltage (% of $V_O$ )	$T_A = 25^\circ C$ $f = 10\text{Hz}$ to $10\text{KHz}$		0.003		%
S	Temperature Stability			0.5		%
S	Long Term Stability	$T_A = 125^\circ C$ 1000Hrs		0.5		%

NOTE 1: See short-circuit current curve for available output current at fixed dropout.

**ELECTRICAL CHARACTERISTICS OF LD1084#8** ( $V_I=11V$ ,  $C_I = C_O = 10\mu F$ ,  $T_A = -40$  to  $125^\circ C$ , unless otherwise specified.)

Symbol	Parameter	Test Conditions	Min.	Typ.	Max.	Unit
$V_O$	Output Voltage	$I_O = 0 \text{ mA}$ $T_J = 25^\circ C$	7.92	8	8.08	V
		$I_O = 0$ to $5A$ $V_I = 9.6$ to $30V$ (note 1)	7.84	8	8.16	V
$\Delta V_O$	Line Regulation	$I_O = 0 \text{ mA}$ $V_I = 9.6$ to $20V$ $T_J = 25^\circ C$		1	18	mV
		$I_O = 0 \text{ mA}$ $V_I = 9.6$ to $20V$		2	18	mV
$\Delta V_O$	Load Regulation	$I_O = 0$ to $5A$ $T_J = 25^\circ C$		8	30	mV
		$I_O = 0$ to $5A$		12	60	V
$V_d$	Dropout Voltage	$I_O = 5 \text{ A}$		1.3	1.5	V
$I_q$	Quiescent Current	$V_I \leq 30V$		5	10	mA
$I_{sc}$	Short Circuit Current	$V_I - V_O = 5V$	5.5	6.5		A
		$V_I - V_O = 25V$	0.5	0.7		A
	Thermal Regulation	$T_A = 25^\circ C$ , 30ms pulse		0.003	0.015	%/W
SVR	Supply Voltage Rejection	$f = 120 \text{ Hz}$ , $C_O = 25 \mu F$ , $I_O = 5A$ $V_I = 13 \pm 3V$	54	71		dB
eN	RMS Output Noise Voltage (% of $V_O$ )	$T_A = 25^\circ C$ $f = 10\text{Hz}$ to $10\text{KHz}$		0.003		%
S	Temperature Stability			0.5		%
S	Long Term Stability	$T_A = 125^\circ C$ 1000Hrs		0.5		%

NOTE 1: See short-circuit current curve for available output current at fixed dropout.

**ELECTRICAL CHARACTERISTICS OF LD1084#9** ( $V_I=12V$ ,  $C_I = C_O = 10\mu F$ ,  $T_A = -40$  to  $125^\circ C$ , unless otherwise specified.)

Symbol	Parameter	Test Conditions	Min.	Typ.	Max.	Unit
$V_O$	Output Voltage	$I_O = 0 \text{ mA}$ $T_J = 25^\circ C$	8.91	9	9.09	V
		$I_O = 0$ to $5A$ $V_I = 10.6$ to $30V$ (note 1)	8.82	9	9.18	V
$\Delta V_O$	Line Regulation	$I_O = 0 \text{ mA}$ $V_I = 10.6$ to $20V$ $T_J = 25^\circ C$		1	20	mV
		$I_O = 0 \text{ mA}$ $V_I = 10.6$ to $20V$		2	20	mV
$\Delta V_O$	Load Regulation	$I_O = 0$ to $5A$ $T_J = 25^\circ C$		8	30	mV
		$I_O = 0$ to $5A$		12	60	V
$V_d$	Dropout Voltage	$I_O = 5 \text{ A}$		1.3	1.5	V
$I_q$	Quiescent Current	$V_I \leq 30V$		5	10	mA
$I_{sc}$	Short Circuit Current	$V_I - V_O = 5V$	5.5	6.5		A
		$V_I - V_O = 25V$	0.5	0.7		A
	Thermal Regulation	$T_A = 25^\circ C$ , 30ms pulse		0.003	0.015	%/W
SVR	Supply Voltage Rejection	$f = 120 \text{ Hz}$ , $C_O = 25 \mu F$ , $I_O = 5A$ $V_I = 14 \pm 3V$	54	70		dB
eN	RMS Output Noise Voltage (% of $V_O$ )	$T_A = 25^\circ C$ $f = 10\text{Hz}$ to $10\text{KHz}$		0.003		%
S	Temperature Stability			0.5		%
S	Long Term Stability	$T_A = 125^\circ C$ 1000Hrs		0.5		%

NOTE 1: See short-circuit current curve for available output current at fixed dropout.

## LD1084 SERIES

**ELECTRICAL CHARACTERISTICS OF LD1084#120** ( $V_I=15V$ ,  $C_I=C_O=10\mu F$ ,  $T_A=-40$  to  $125^\circ C$ , unless otherwise specified.)

Symbol	Parameter	Test Conditions	Min.	Typ.	Max.	Unit
$V_O$	Output Voltage	$I_O = 0 \text{ mA}$ $T_J = 25^\circ C$	11.88	12	12.12	V
		$I_O = 0$ to $5A$ $V_I = 13.6$ to $30V$ (note 1)	11.76	12	12.24	V
$\Delta V_O$	Line Regulation	$I_O = 0 \text{ mA}$ $V_I = 13.6$ to $25V$ $T_J = 25^\circ C$		2	25	mV
		$I_O = 0 \text{ mA}$ $V_I = 13.6$ to $25V$		4	25	mV
$\Delta V_O$	Load Regulation	$I_O = 0$ to $5A$ $T_J = 25^\circ C$		12	36	mV
		$I_O = 0$ to $5A$		24	72	V
$V_d$	Dropout Voltage	$I_O = 5A$		1.3	1.5	V
$I_q$	Quiescent Current	$V_I \leq 30V$		5	10	mA
$I_{sc}$	Short Circuit Current	$V_I - V_O = 5V$	5.5	6.5		A
		$V_I - V_O = 25V$	0.5	0.7		A
	Thermal Regulation	$T_A = 25^\circ C$ , 30ms pulse		0.003	0.015	%/W
SVR	Supply Voltage Rejection	$f = 120 \text{ Hz}$ , $C_O = 25 \mu F$ , $I_O = 5A$ $V_I = 17 \pm 3V$	54	66		dB
eN	RMS Output Noise Voltage (% of $V_O$ )	$T_A = 25^\circ C$ $f = 10\text{Hz}$ to $10\text{KHz}$		0.003		%
S	Temperature Stability			0.5		%
S	Long Term Stability	$T_A = 125^\circ C$ 1000Hrs		0.5		%

NOTE 1: See short-circuit current curve for available output current at fixed dropout.

**ELECTRICAL CHARACTERISTICS OF LD1084** ( $V_I=4.25V$ ,  $C_I=C_O=10\mu F$ ,  $T_A=-40$  to  $125^\circ C$ , unless otherwise specified.)

Symbol	Parameter	Test Conditions	Min.	Typ.	Max.	Unit
$V_O$	Output Voltage	$I_O = 10\text{mA}$ $T_J = 25^\circ C$	1.237	1.25	1.263	V
		$I_O = 10\text{mA}$ to $5A$ $V_I = 2.85$ to $30V$ (note 1)	1.225	1.25	1.275	V
$\Delta V_O$	Line Regulation	$I_O = 10\text{mA}$ $V_I = 2.85$ to $16.5V$ $T_J = 25^\circ C$		0.015	0.2	%
		$I_O = 10\text{mA}$ $V_I = 2.85$ to $16.5V$		0.035	0.2	%
$\Delta V_O$	Load Regulation	$I_O = 10\text{mA}$ to $5A$ $T_J = 25^\circ C$		0.1	0.3	%
		$I_O = 10\text{mA}$ to $5A$		0.2	0.4	%
$V_d$	Dropout Voltage	$I_O = 5A$		1.3	1.5	V
$I_{O(\min)}$	Minimum Load Current	$V_I = 30V$		3	10	mA
$I_{sc}$	Short Circuit Current	$V_I - V_O = 5V$	5.5	6.5		A
		$V_I - V_O = 25V$	0.5	0.7		A
	Thermal Regulation	$T_A = 25^\circ C$ , 30ms pulse		0.003	0.015	%/W
SVR	Supply Voltage Rejection	$f = 120 \text{ Hz}$ , $C_O = 25 \mu F$ , $C_{ADJ} = 25 \mu F$ , $I_O = 5A$ $V_I = 6.25 \pm 3V$	60	72		dB
$I_{ADJ}$	Adjust Pin Current	$V_I = 4.25V$ $I_O = 10 \text{ mA}$		55	120	$\mu A$
$\Delta I_{ADJ}$	Adjust Pin Current Change	$I_O = 10\text{mA}$ to $5A$ $V_I = 2.85$ to $16.5V$ (note 1)		0.2	5	$\mu A$
eN	RMS Output Noise Voltage (% of $V_O$ )	$T_A = 25^\circ C$ $f = 10\text{Hz}$ to $10\text{KHz}$		0.003		%
S	Temperature Stability			0.5		%
S	Long Term Stability	$T_A = 125^\circ C$ 1000Hrs		0.5		%

NOTE 1: See short-circuit current curve for available output current at fixed dropout.



**TYPICAL CHARACTERISTICS** (unless otherwise specified  $T_J = 25^\circ\text{C}$ ,  $C_I = 10\mu\text{F}$  (tant.),  $C_O = 22\mu\text{F}$  (tant.))

**Figure 1 : Short Circuit Current vs Dropout Voltage**

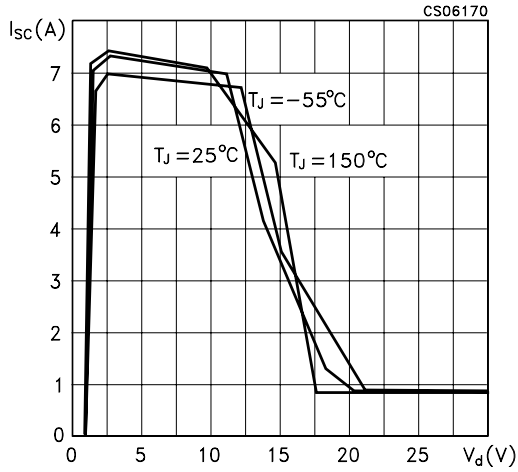

**Figure 2 : Line Regulation vs Temperature**

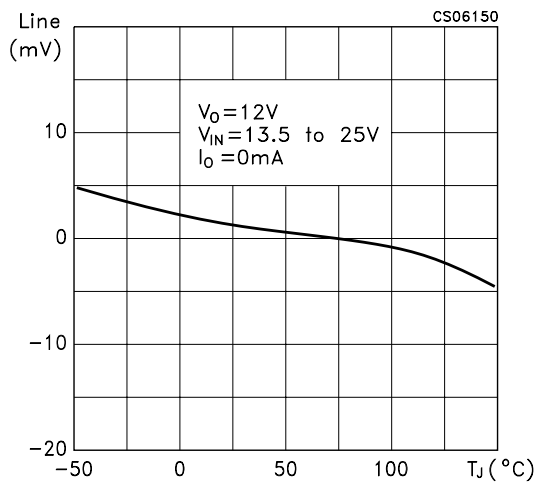

**Figure 3 : Quiescent Current vs Temperature**

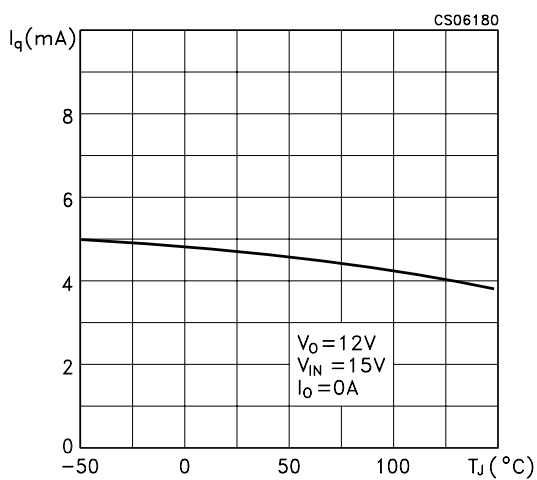

**Figure 4 : Output Voltage vs Temperature**

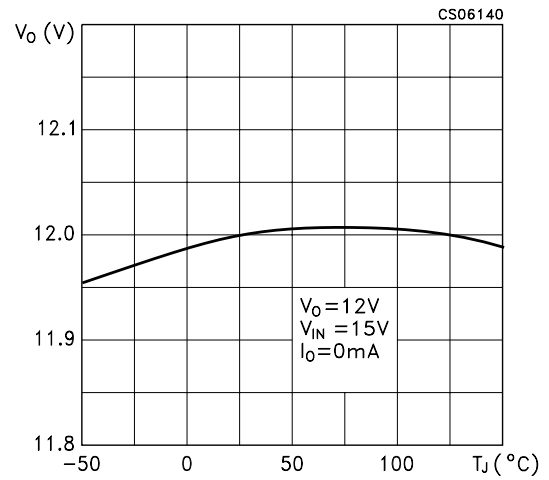

**Figure 5 : Load Regulation vs Temperature**

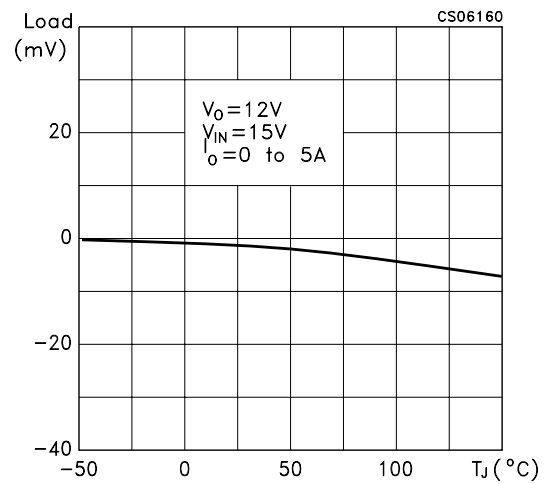

**Figure 6 : Quiescent Current vs Output Voltage**

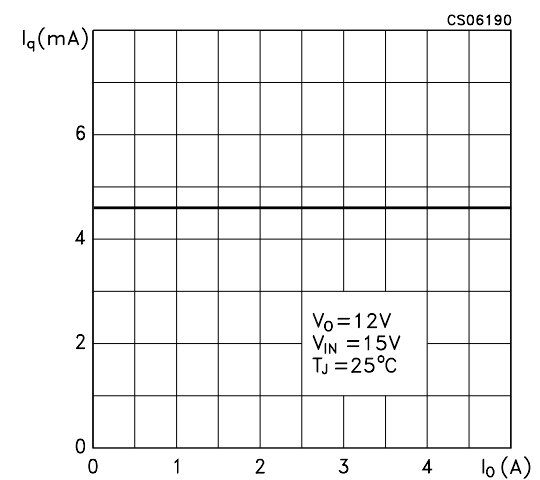

Figure 7 : Quiescent Current vs Input Voltage

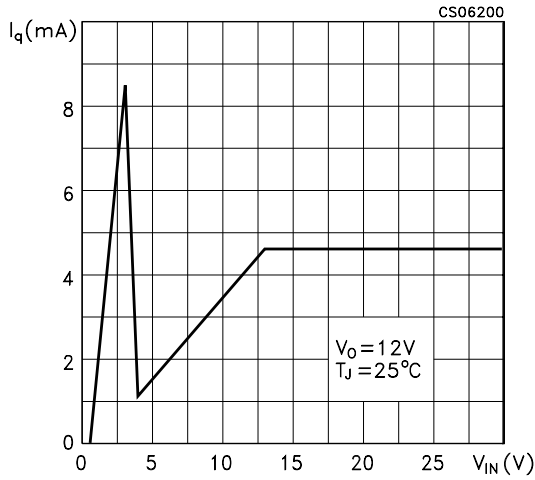

Figure 8 : Dropout Voltage vs Output Current

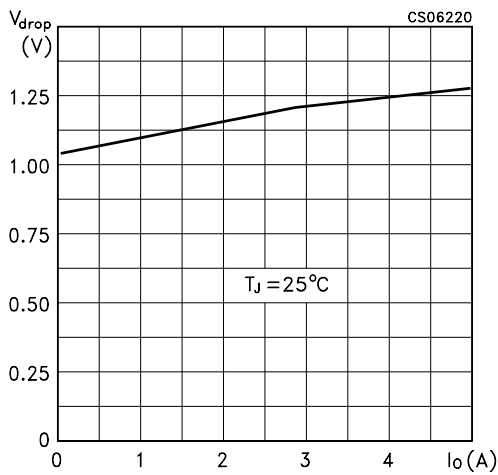

Figure 9 : Supply Voltage Rejection vs Output Current

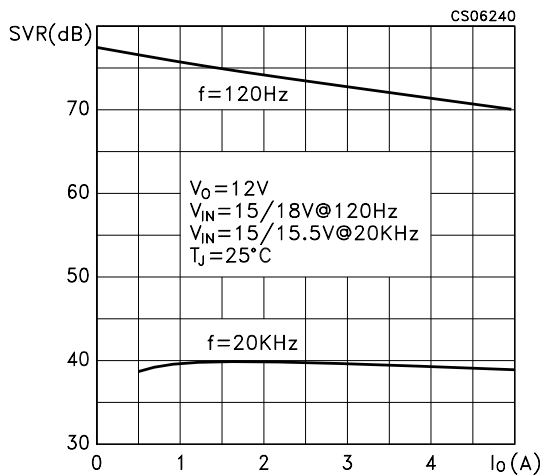

Figure 10 : Dropout Voltage vs Temperature

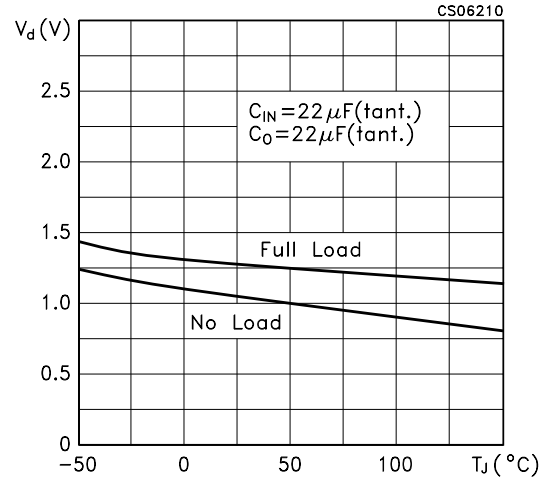

Figure 11 : Supply Voltage Rejection vs Temperature

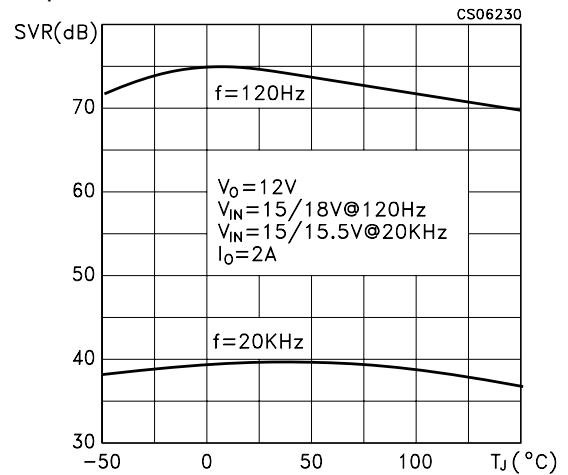

Figure 12 : Supply Voltage Rejection vs Frequency

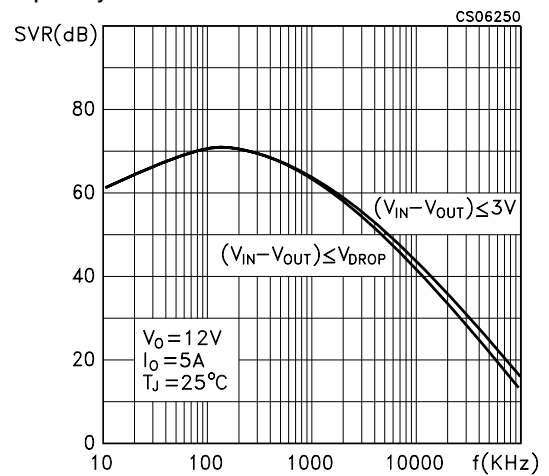

Figure 13 : Adjust Pin Current vs Output Current

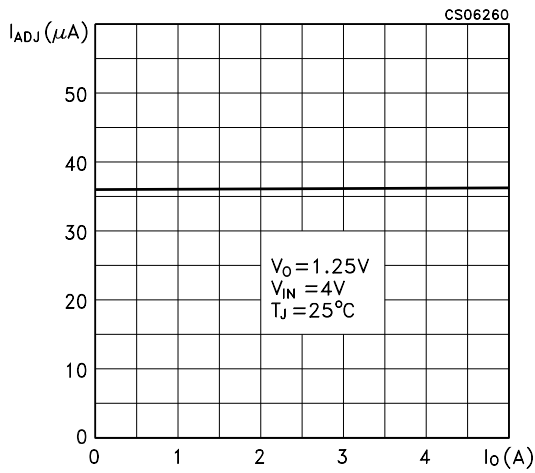

Figure 16 : Adjust Pin Current vs Temperature

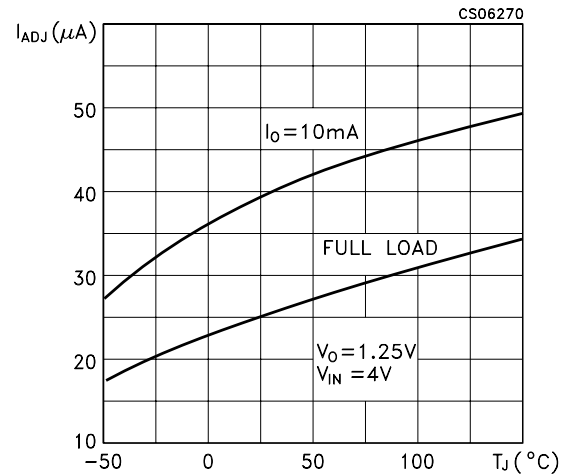

Figure 14 : Reference Voltage vs Temperature

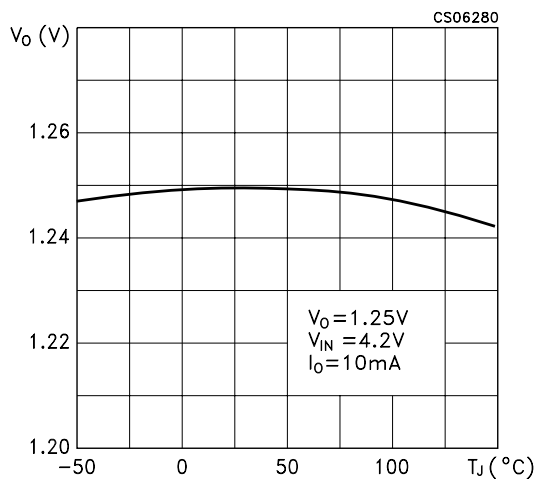

Figure 17 : Line Regulation vs Temperature

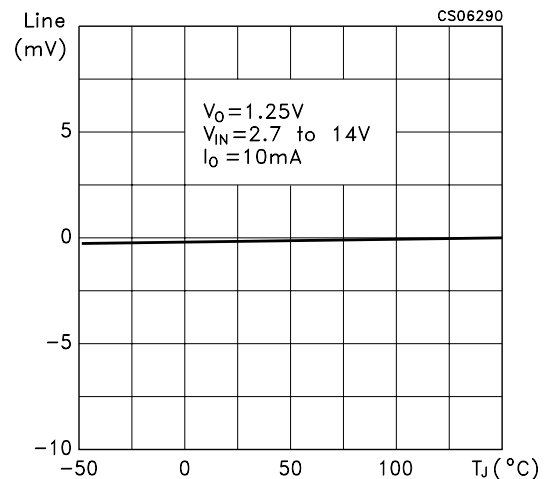

Figure 15 : Load Regulation vs Temperature

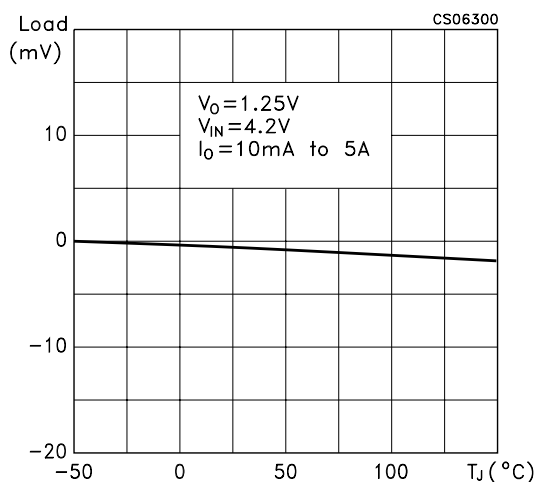

Figure 18 : Minimum Load Current vs Temperature

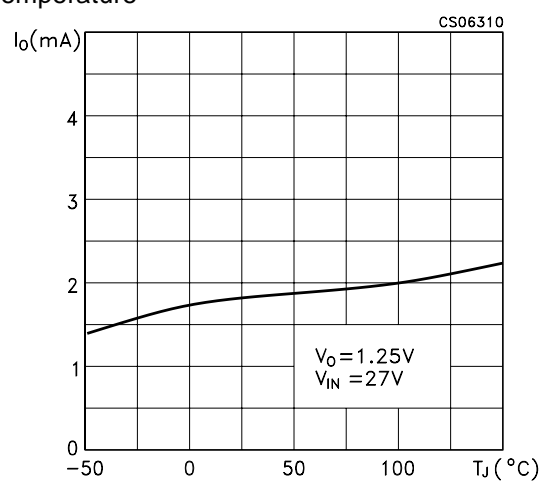

Figure 19 : Supply Voltage Rejection vs Temperature

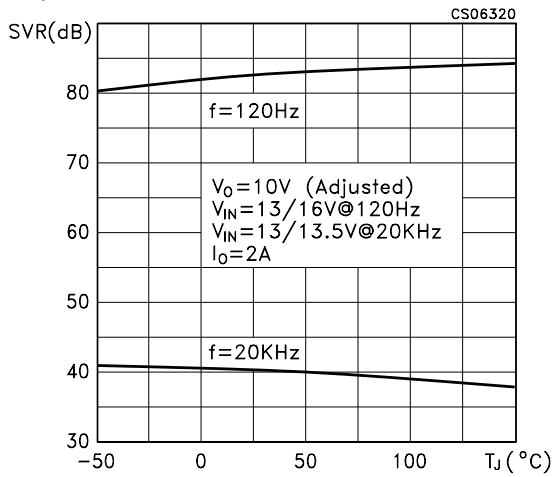

Figure 22 : Supply Voltage Rejection vs Output Current

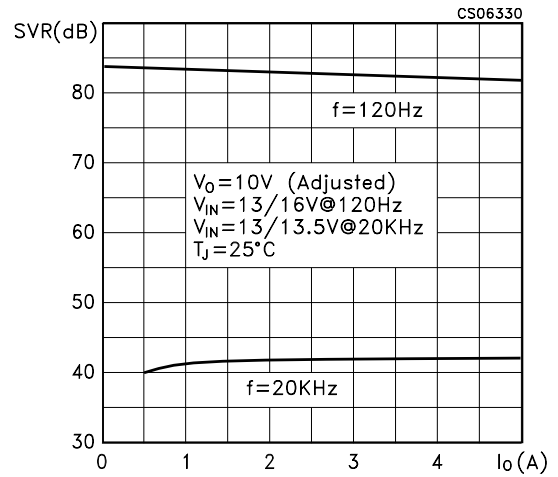

Figure 20 : Supply Voltage Rejection vs Frequency

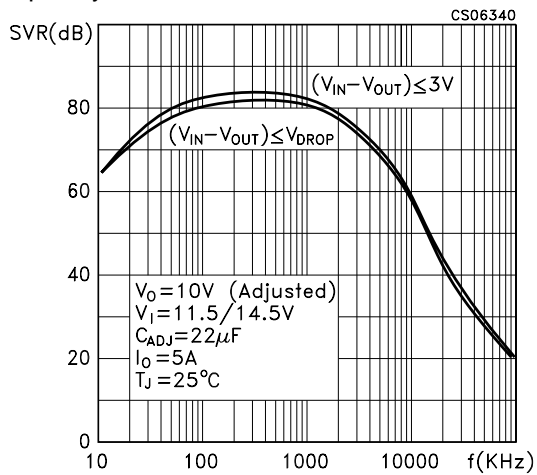

Figure 23 : Stability

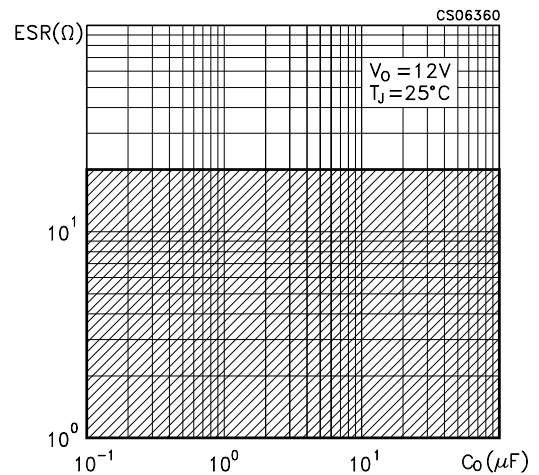

Figure 21 : Stability

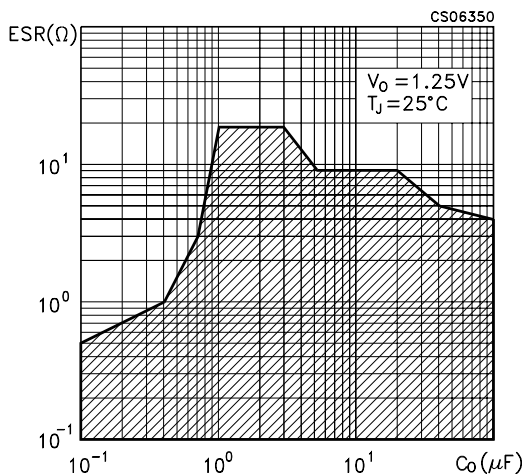

Figure 24 : Line Transient

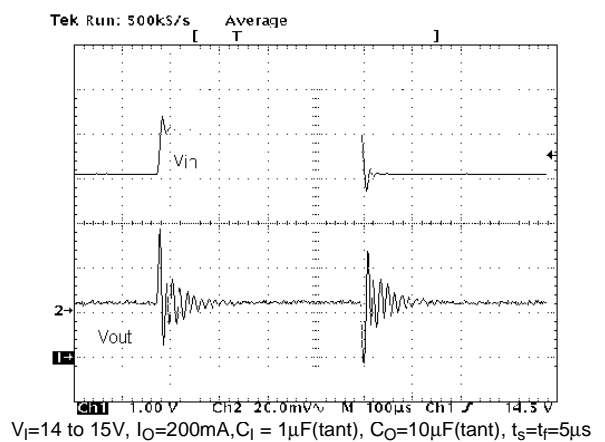

Figure 25 : Line Transient

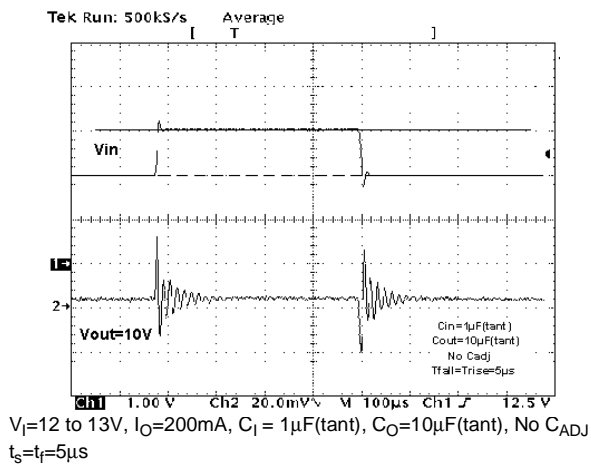

Figure 28 : Line Transient

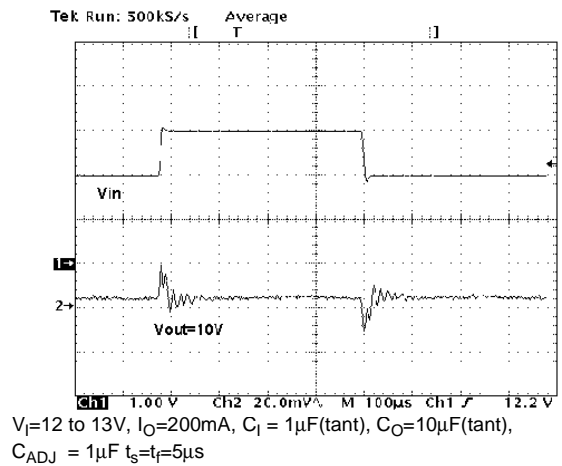

Figure 26 : Load Transient

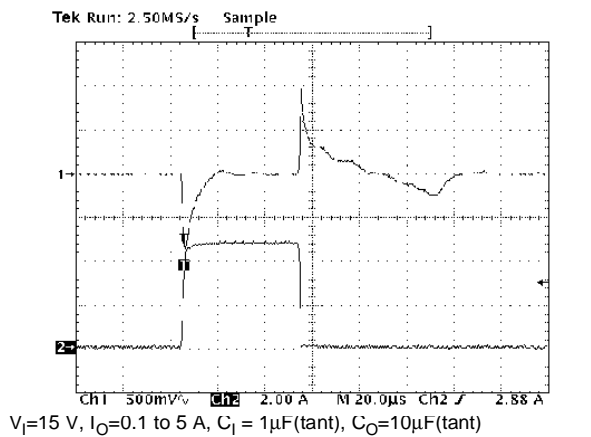

Figure 29 : Load Transient

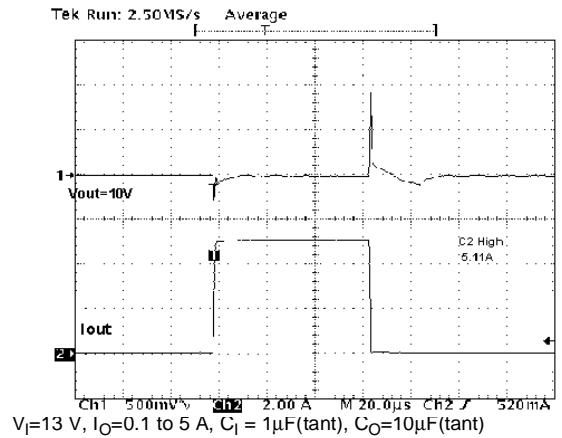
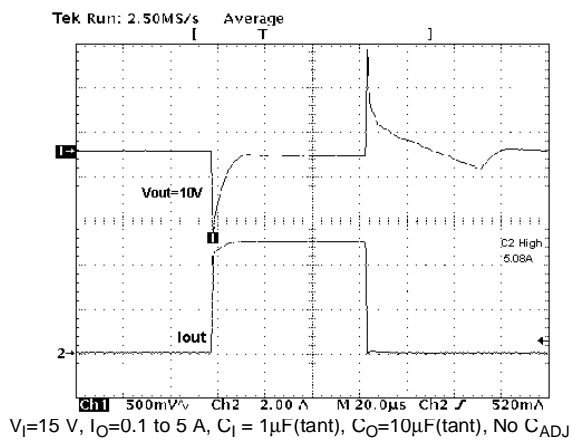
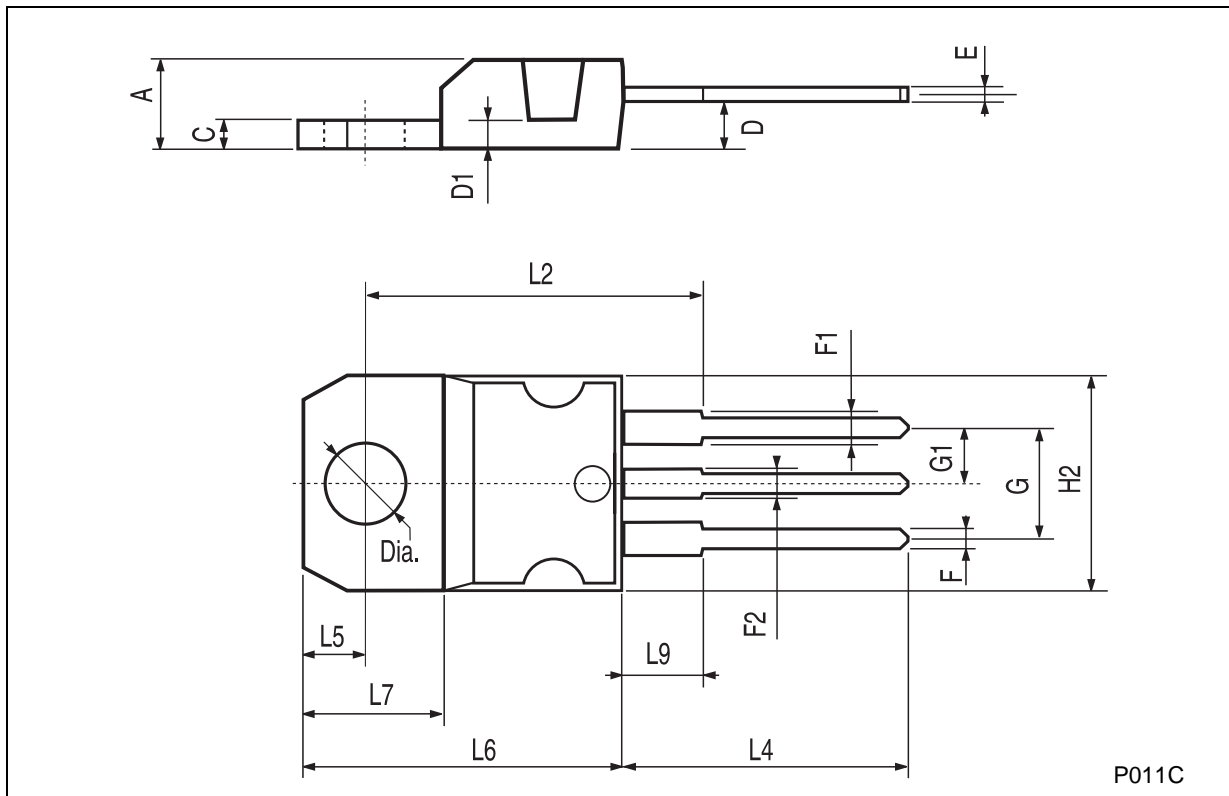

Figure 27 : Load Transient



TO-220 MECHANICAL DATA

DIM.	mm.			inch		
	MIN.	TYP	MAX.	MIN.	TYP.	MAX.
A	4.40		4.60	0.173		0.181
C	1.23		1.32	0.048		0.051
D	2.40		2.72	0.094		0.107
D1		1.27			0.050	
E	0.49		0.70	0.019		0.027
F	0.61		0.88	0.024		0.034
F1	1.14		1.70	0.044		0.067
F2	1.14		1.70	0.044		0.067
G	4.95		5.15	0.194		0.203
G1	2.4		2.7	0.094		0.106
H2	10.0		10.40	0.393		0.409
L2		16.4			0.645	
L4	13.0		14.0	0.511		0.551
L5	2.65		2.95	0.104		0.116
L6	15.25		15.75	0.600		0.620
L7	6.2		6.6	0.244		0.260
L9	3.5		3.93	0.137		0.154
DIA.	3.75		3.85	0.147		0.151



D<sup>2</sup>PAK MECHANICAL DATA

DIM.	mm.			inch		
	MIN.	TYP	MAX.	MIN.	TYP.	MAX.
A	4.4		4.6	0.173		0.181
A1	2.49		2.69	0.098		0.106
A2	0.03		0.23	0.001		0.009
B	0.7		0.93	0.027		0.036
B2	1.14		1.7	0.044		0.067
C	0.45		0.6	0.017		0.023
C2	1.23		1.36	0.048		0.053
D	8.95		9.35	0.352		0.368
D1		8			0.315	
E	10		10.4	0.393		0.409
E1		8.5			0.335	
G	4.88		5.28	0.192		0.208
L	15		15.85	0.590		0.624
L2	1.27		1.4	0.050		0.055
L3	1.4		1.75	0.055		0.068
M	2.4		3.2	0.094		0.126
R		0.4			0.016	
V2	0°		8°	0°		8°

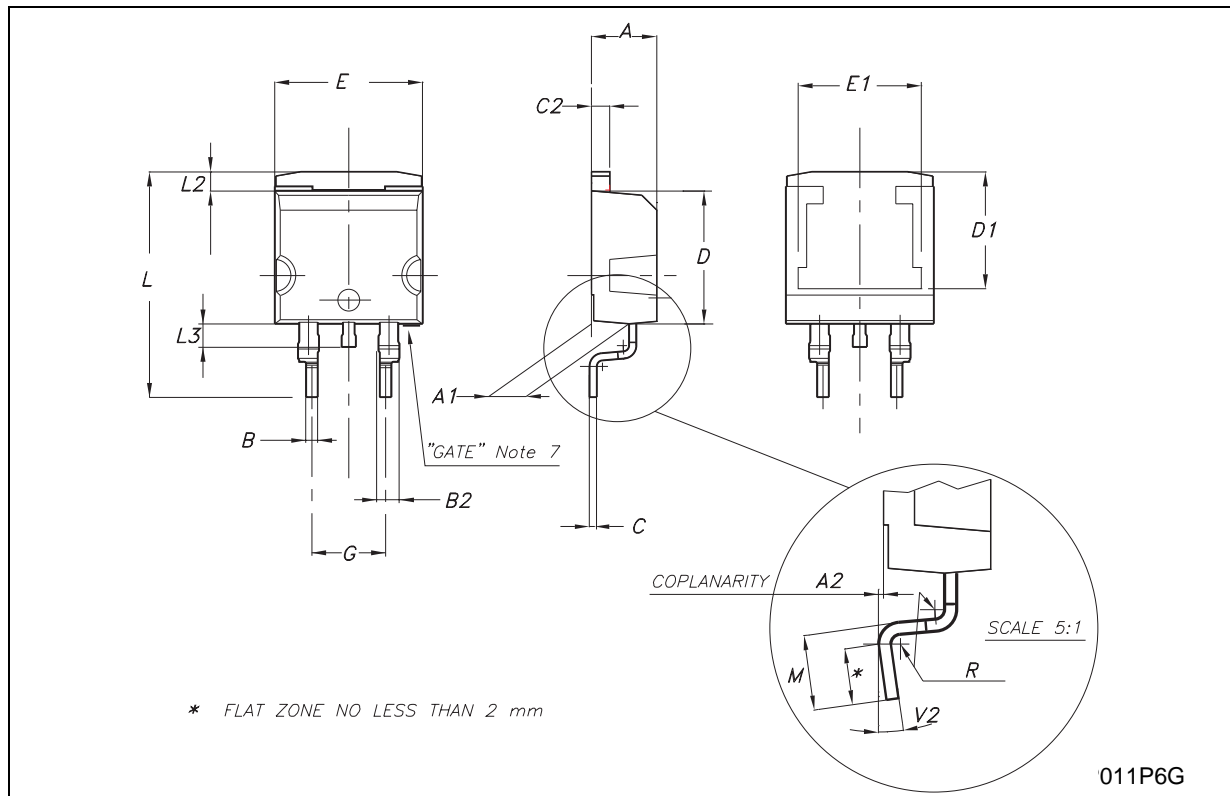

**D<sup>2</sup>PAK/A MECHANICAL DATA**

DIM.	mm.			inch		
	MIN.	TYP	MAX.	MIN.	TYP.	MAX.
A	4.40		4.60	0.173		0.181
A1	2.49		2.69	0.098		0.106
B	0.7		0.93	0.027		0.036
B2	1.14		1.7	0.044		0.067
C	0.45		0.60	0.017		0.023
C2	1.21		1.36	0.047		0.053
D	8.95		9.35	0.352		0.368
E	10		10.4	0.393		0.409
G	4.88		5.28	0.192		0.208
L	15		15.85	0.590		0.106
L2	1.27		1.4	0.050		0.055

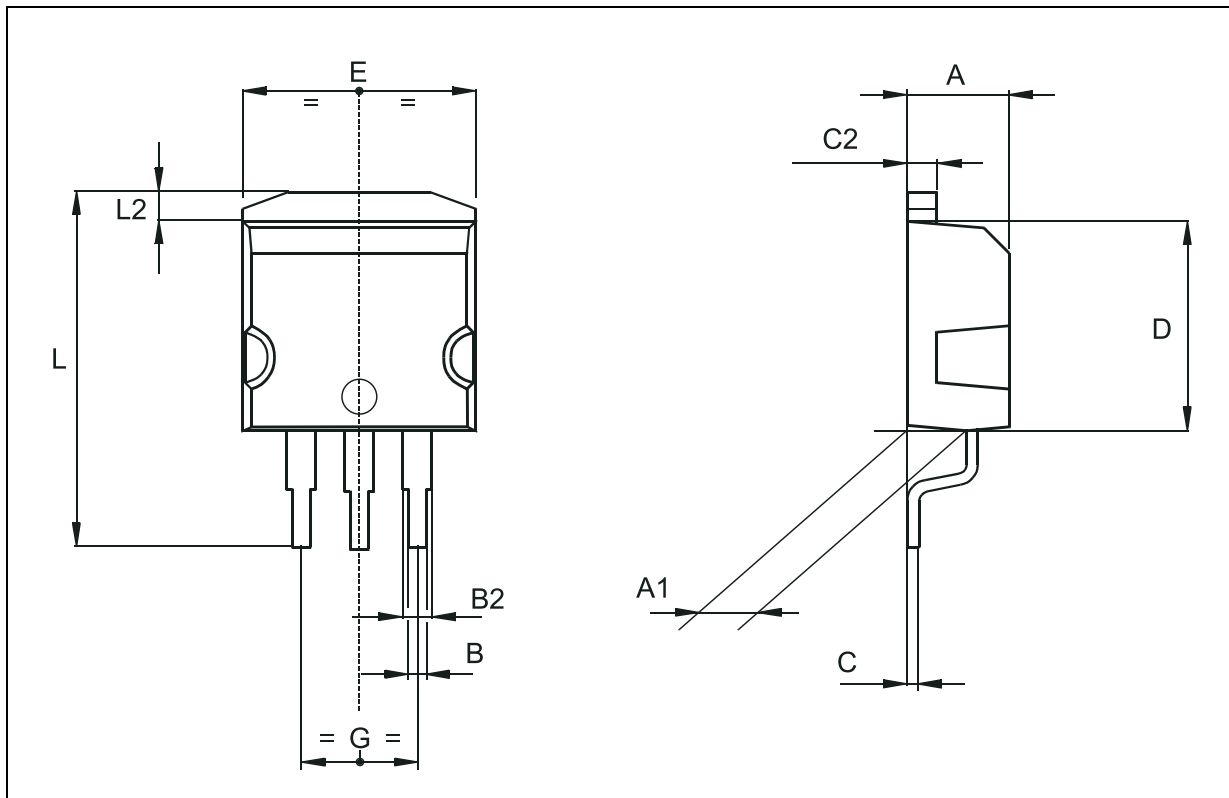



**Tape & Reel D<sup>2</sup>PAK-P<sup>2</sup>PAK-D<sup>2</sup>PAK/A-P<sup>2</sup>PAK/A MECHANICAL DATA**

DIM.	mm.			inch		
	MIN.	TYP	MAX.	MIN.	TYP.	MAX.
A			180			7.086
C	12.8	13.0	13.2	0.504	0.512	0.519
D	20.2			0.795		
N	60			2.362		
T			14.4			0.567
Ao	10.50	10.6	10.70	0.413	0.417	0.421
Bo	15.70	15.80	15.90	0.618	0.622	0.626
Ko	4.80	4.90	5.00	0.189	0.193	0.197
Po	3.9	4.0	4.1	0.153	0.157	0.161
P	11.9	12.0	12.1	0.468	0.472	0.476

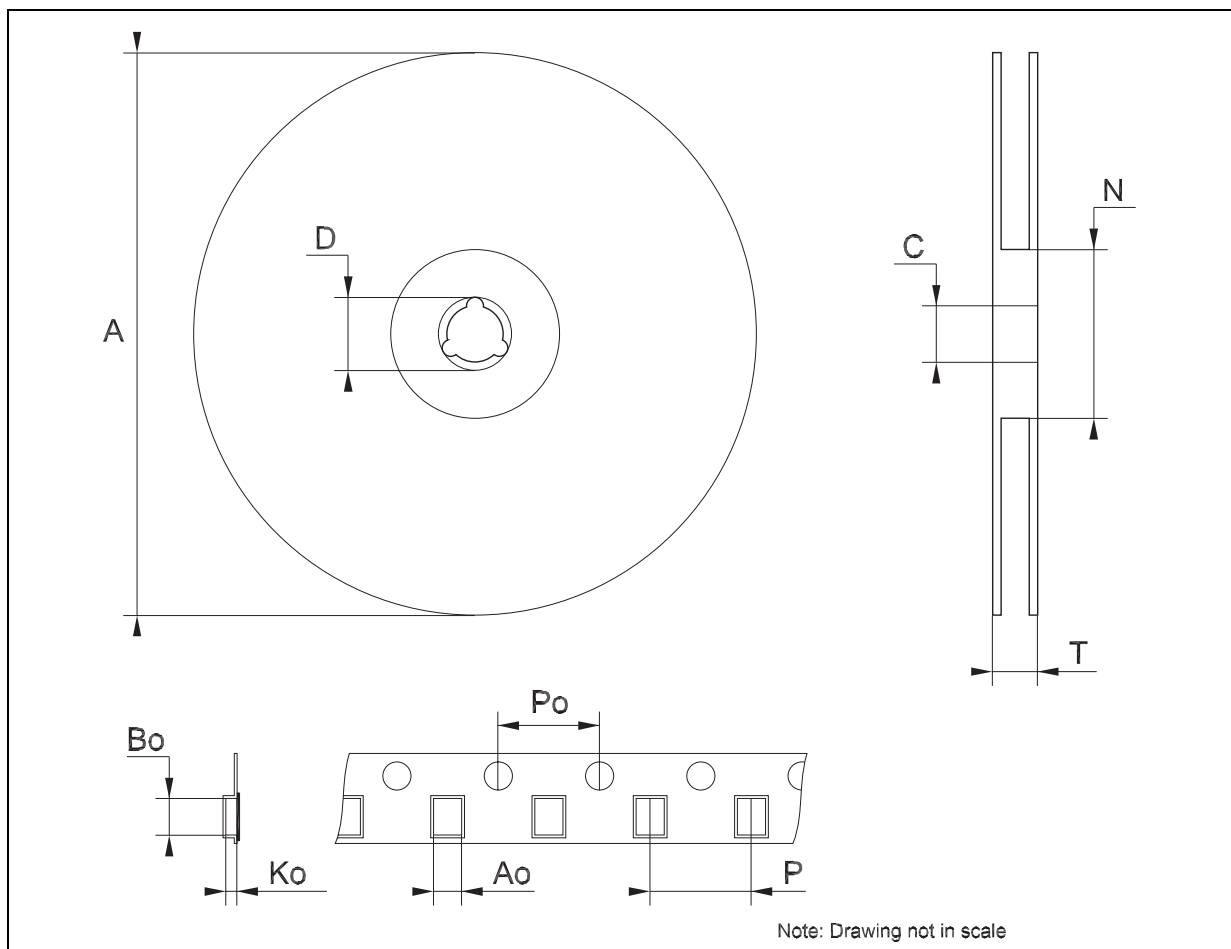

Information furnished is believed to be accurate and reliable. However, STMicroelectronics assumes no responsibility for the consequences of use of such information nor for any infringement of patents or other rights of third parties which may result from its use. No license is granted by implication or otherwise under any patent or patent rights of STMicroelectronics. Specifications mentioned in this publication are subject to change without notice. This publication supersedes and replaces all information previously supplied. STMicroelectronics products are not authorized for use as critical components in life support devices or systems without express written approval of STMicroelectronics.

© The ST logo is a registered trademark of STMicroelectronics

© 2003 STMicroelectronics - Printed in Italy - All Rights Reserved  
STMicroelectronics GROUP OF COMPANIES

Australia - Brazil - Canada - China - Finland - France - Germany - Hong Kong - India - Israel - Italy - Japan - Malaysia - Malta - Morocco  
Singapore - Spain - Sweden - Switzerland - United Kingdom - United States.

© <http://www.st.com>