



M36W216TI M36W216BI

16 Mbit (1Mb x16, Boot Block) Flash Memory and 2 Mbit (128Kb x16) SRAM, Multiple Memory Product

PRELIMINARY DATA

FEATURES SUMMARY

- MULTIPLE MEMORY PRODUCT
 - 16 Mbit (1Mb x 16) Boot Block Flash Memory
 - 2 Mbit (128Kb x 16) SRAM
- SUPPLY VOLTAGE
 - $V_{DDF} = V_{DDS} = 2.7V$ to 3.3V
 - $V_{DDQF} = V_{DDS} = 2.7V$ to 3.3V
 - $V_{PPF} = 12V$ for Fast Program (optional)
- ACCESS TIME: 70ns, 85ns
- LOW POWER CONSUMPTION
- ELECTRONIC SIGNATURE
 - Manufacturer Code: 20h
 - Top Device Code, M36W216TI: 88CEh
 - Bottom Device Code, M36W216BI: 88CFh

FLASH MEMORY

- MEMORY BLOCKS
 - Parameter Blocks (Top or Bottom location)
 - Main Blocks
- PROGRAMMING TIME
 - 10 μ s typical
 - Double Word Programming Option
- BLOCK LOCKING
 - All blocks locked at Power up
 - Any combination of blocks can be locked
 - \overline{WP}_F for Block Lock-Down
- AUTOMATIC STAND-BY MODE
- PROGRAM and ERASE SUSPEND
- 100,000 PROGRAM/ERASE CYCLES per BLOCK
- COMMON FLASH INTERFACE
 - 64 bit Security Code
- SECURITY
 - 64 bit user programmable OTP cells
 - 64 bit unique device identifier
 - One parameter block permanently lockable

SRAM

- 2 Mbit (128K x 16 bit)
- ACCESS TIME: 70ns
- LOW V_{DDs} DATA RETENTION: 1.5V
- POWER DOWN FEATURES USING TWO CHIP ENABLE INPUTS

Figure 1. Packages

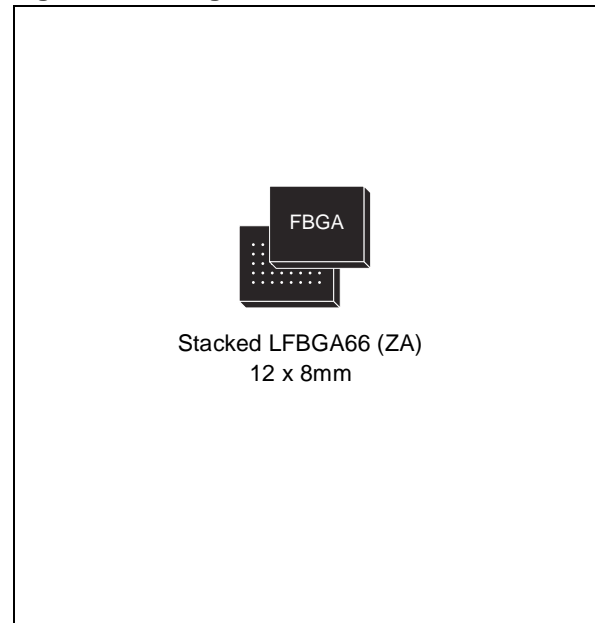

TABLE OF CONTENTS

SUMMARY DESCRIPTION 6

 Figure 2. Logic Diagram 6

 Table 1. Signal Names 6

 Figure 3. LFBGA Connections (Top view through package) 7

SIGNAL DESCRIPTION 8

 Address Inputs (A0-A16). 8

 Address Inputs (A17-A19). 8

 Data Inputs/Outputs (DQ0-DQ15). 8

 Flash Chip Enable (EF). 8

 Flash Output Enable (GF). 8

 Flash Write Enable (WF). 8

 Flash Write Protect (WPF). 8

 Flash Reset (RPF). 8

 SRAM Chip Enable (E1S, E2S). 8

 SRAM Write Enable (WS). 8

 SRAM Output Enable (GS). 8

 SRAM Upper Byte Enable (UBS). 8

 SRAM Lower Byte Enable (LBS). 8

 V_{DDF} and V_{DDS} Supply Voltages. 8

 V_{DDQF} and V_{DDQD} Supply Voltage (2.7V to 3.3V). 8

 V_{PPF} Program Supply Voltage. 8

 V_{SSF} and V_{SSS} Ground. 9

FUNCTIONAL DESCRIPTION 9

 Figure 4. Functional Block Diagram 9

 Table 2. Main Operation Modes 10

MAXIMUM RATING 11

 Table 3. Absolute Maximum Ratings. 11

DC AND AC PARAMETERS 12

 Table 4. Operating and AC Measurement Conditions 12

 Figure 5. AC Measurement I/O Waveform 12

 Figure 6. AC Measurement Load Circuit 12

 Table 5. Device Capacitance. 12

 Table 6. DC Characteristics. 13

PACKAGE MECHANICAL 15

 Figure 7. Stacked LFBGA66-12x8mm, 8x8 ball array, 0.8mm pitch, Bottom View Package Outline 15

 Table 7. Stacked LFBGA66 - 12x8mm, 8x8 ball array, 0.8 mm pitch, Package Mechanical Data . 15

 Figure 8. Stacked LFBGA66 Daisy Chain - Package Connections (Top view through package) . . 16

 Figure 9. Stacked LFBGA66 Daisy Chain - PCB Connections proposal (Top view through package). 17

PART NUMBERING	18
Table 8. Ordering Information Scheme	18
Table 9. Daisy Chain Ordering Scheme	18
FLASH DEVICE	19
FLASH SUMMARY DESCRIPTION	19
Figure 10. Flash Block Addresses	20
Figure 11. Flash Security Block and Protection Register Memory Map	20
FLASH BUS OPERATIONS	21
Read	21
Write	21
Output Disable	21
Standby	21
Automatic Standby	21
Reset	21
FLASH COMMAND INTERFACE	22
Read Memory Array Command	22
Read Status Register Command	22
Read Electronic Signature Command	22
Read CFI Query Command	22
Block Erase Command	22
Program Command	22
Double Word Program Command	23
Clear Status Register Command	23
Program/Erase Suspend Command	23
Program/Erase Resume Command	23
Protection Register Program Command	23
Block Lock Command	24
Block Unlock Command	24
Block Lock-Down Command	24
Table 10. Flash Commands	25
Table 11. Read Electronic Signature	25
Table 12. Read Block Lock Signature	26
Table 13. Read Protection Register and Lock Register	26
Table 14. Program, Erase Times and Program/Erase Endurance Cycles	26
FLASH BLOCK LOCKING	27
Reading a Block's Lock Status	27
Locked State	27
Unlocked State	27
Lock-Down State	27
Locking Operations During Erase Suspend	27
Table 15. Block Lock Status	28
Table 16. Protection Status	28

FLASH STATUS REGISTER	29
Program/Erase Controller Status (Bit 7)	29
Erase Suspend Status (Bit 6)	29
Erase Status (Bit 5)	29
Program Status (Bit 4)	29
V _{PP} Status (Bit 3)	29
Program Suspend Status (Bit 2)	29
Block Protection Status (Bit 1)	30
Reserved (Bit 0)	30
Table 17. Status Register Bits	30
Figure 12. Flash Read Mode AC Waveforms	31
Table 18. Flash Read AC Characteristics	31
Figure 13. Flash Write AC Waveforms, Write Enable Controlled	32
Table 19. Flash Write AC Characteristics, Write Enable Controlled	33
Figure 14. Flash Write AC Waveforms, Chip Enable Controlled	34
Table 20. Flash Write AC Characteristics, Chip Enable Controlled	35
Figure 15. Flash Power-Up and Reset AC Waveforms	36
Table 21. Flash Power-Up and Reset AC Characteristics	36
 SRAM DEVICE	 37
SRAM SUMMARY DESCRIPTION	37
Figure 16. SRAM Logic Diagram	37
SRAM OPERATIONS	38
Read	38
Write	38
Standby/Power-Down	38
Data Retention	38
Output Disable	38
Figure 17. SRAM Read Mode AC Waveforms, Address Controlled with UBS = LBS = V _{IL}	39
Figure 18. SRAM Read AC Waveforms, GS Controlled	39
Figure 19. SRAM Standby AC Waveforms	39
Table 22. SRAM Read AC Characteristics	40
Figure 20. SRAM Write AC Waveforms, WS Controlled	41
Figure 21. SRAM Write AC Waveforms, E1S Controlled	42
Figure 22. SRAM Write AC Waveforms, WS Controlled with GS Low	43
Figure 23. SRAM Write Cycle Waveform, UBS and LBS Controlled, GS Low	43
Table 23. SRAM Write AC Characteristics	44
Figure 24. SRAM Low V _{DDS} Data Retention AC Waveforms, E1 _S or UB _S / LB _S Controlled ..	45
Table 24. SRAM Low V _{DDS} Data Retention Characteristic	45
 APPENDIX A. BLOCK ADDRESS TABLES	 46
Table 25. Top Boot Block Addresses, M36W216TI	46
Table 26. Bottom Boot Block Addresses, M36W216BI	46

APPENDIX B. COMMON FLASH INTERFACE (CFI)	47
Table 27. Query Structure Overview	47
Table 28. CFI Query Identification String	47
Table 29. CFI Query System Interface Information	48
Table 30. Device Geometry Definition	49
Table 31. Primary Algorithm-Specific Extended Query Table	50
Table 32. Security Code Area	51
APPENDIX C. FLOWCHARTS AND PSEUDO CODES	52
Figure 25. Program Flowchart and Pseudo Code	52
Figure 26. Double Word Program Flowchart and Pseudo Code	53
Figure 27. Program Suspend & Resume Flowchart and Pseudo Code	54
Figure 28. Erase Flowchart and Pseudo Code	55
Figure 29. Erase Suspend & Resume Flowchart and Pseudo Code	56
Figure 30. Locking Operations Flowchart and Pseudo Code	57
APPENDIX D. COMMAND INTERFACE AND PROGRAM/ERASE CONTROLLER STATE	59
Table 33. Write State Machine Current/Next, sheet 1 of 2	59
Table 34. Write State Machine Current/Next, sheet 2 of 2	60
REVISION HISTORY	61
Table 35. Document Revision History	61

SUMMARY DESCRIPTION

The M36W216TI is a low voltage Multiple Memory Product which combines two memory devices; a 16 Mbit boot block Flash memory and a 2 Mbit SRAM. Recommended operating conditions do not allow both the Flash memory and the SRAM memory to be active at the same time.

The memory is offered in a Stacked LFBGA66 (12x8mm, 8 x 8 active ball, 0.8 mm pitch) package and is supplied with all the bits erased (set to '1').

Figure 2. Logic Diagram

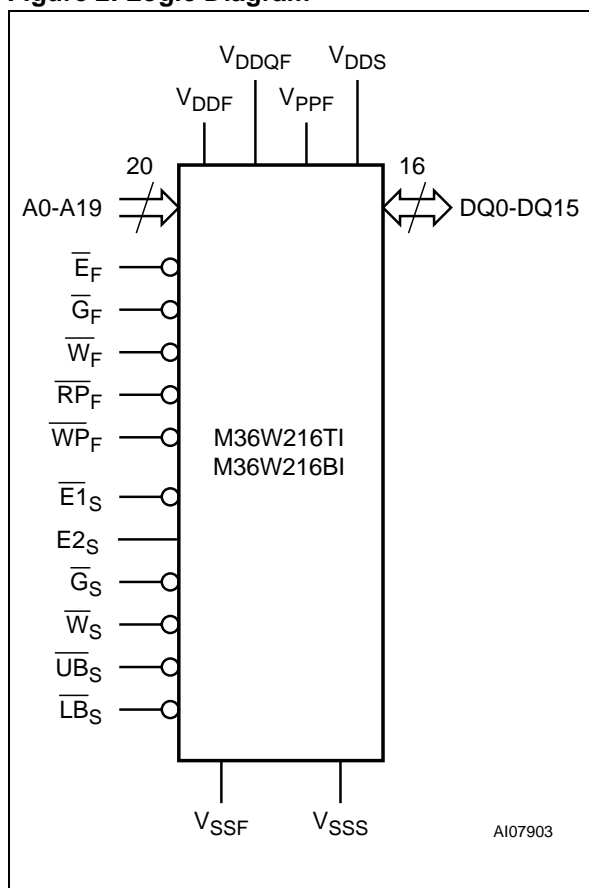

Table 1. Signal Names

A0-A16	Flash and SRAM Address Inputs
A17-A19	Address Inputs for Flash Chip only
DQ0-DQ15	Data Input/Output
VDDF	Flash Power Supply
VDDQF	Flash Power Supply for I/O Buffers
VPPF	Flash Optional Supply Voltage for Fast Program & Erase
VSSF	Flash Ground
VDDS	SRAM Power Supply
VSSS	SRAM Ground
NC	Not Connected Internally
Flash control functions	
EF-bar	Chip Enable input
GF-bar	Output Enable input
WF-bar	Write Enable input
RPF-bar	Reset input
WPF-bar	Write Protect input
SRAM control functions	
E1S-bar, E2S	Chip Enable inputs
GS-bar	Output Enable input
WS-bar	Write Enable input
UBS-bar	Upper Byte Enable input
LBS-bar	Lower Byte Enable input

SIGNAL DESCRIPTION

See Figure 2 Logic Diagram and Table 1, Signal Names, for a brief overview of the signals connected to this device.

Address Inputs (A0-A16). Addresses A0-A16 are common inputs for the Flash and the SRAM components. The Address Inputs select the cells in the memory array to access during Bus Read operations. During Bus Write operations they control the commands sent to the Command Interface of the internal state machine. The Flash memory is accessed through the Chip Enable (\overline{E}_F) and Write Enable (\overline{W}_F) signals, while the SRAM is accessed through two Chip Enable (E_S) and Write Enable (\overline{W}_S) signals.

Address Inputs (A17-A19). Addresses A17-A19 are inputs for the Flash component only. The Flash memory is accessed through the Chip Enable (\overline{E}_F) and Write Enable (\overline{W}_F) signals

Data Inputs/Outputs (DQ0-DQ15). The Data I/O output the data stored at the selected address during a Bus Read operation or input a command or the data to be programmed during a Write Bus operation.

Flash Chip Enable (\overline{E}_F). The Chip Enable input activates the Flash memory control logic, input buffers, decoders and sense amplifiers. When Chip Enable is at V_{IL} and Reset is at V_{IH} the device is in active mode. When Chip Enable is at V_{IH} the memory is deselected, the outputs are high impedance and the power consumption is reduced to the standby level.

Flash Output Enable (\overline{G}_F). The Output Enable controls the data outputs during the Bus Read operation of the Flash memory.

Flash Write Enable (\overline{W}_F). The Write Enable controls the Bus Write operation of the Flash memory's Command Interface. The data and address inputs are latched on the rising edge of Chip Enable, \overline{E}_F , or Write Enable, \overline{W}_F , whichever occurs first.

Flash Write Protect (\overline{WP}_F). Write Protect is an input that gives an additional hardware protection for each block. When Write Protect is at V_{IL} , the Lock-Down is enabled and the protection status of the block cannot be changed. When Write Protect is at V_{IH} , the Lock-Down is disabled and the block can be locked or unlocked. (refer to Table 6, Read Protection Register and Protection Register Lock).

Flash Reset (\overline{RP}_F). The Reset input provides a hardware reset of the Flash memory. When Reset is at V_{IL} , the memory is in reset mode: the outputs are high impedance and the current consumption is minimized. After Reset all blocks are in the Locked state. When Reset is at V_{IH} , the device is in normal operation. Exiting reset mode the device enters read array mode, but a negative transition

of Chip Enable or a change of the address is required to ensure valid data outputs.

SRAM Chip Enable (\overline{E}_1S, E_2S). The Chip Enable inputs activate the SRAM memory control logic, input buffers and decoders. \overline{E}_1S at V_{IH} or E_2S at V_{IL} deselected the memory and reduces the power consumption to the standby level. \overline{E}_1S or E_2S can also be used to control writing to the SRAM memory array, while \overline{W}_S remains at V_{IL} . It is not allowed to set \overline{E}_F at V_{IL} and, \overline{E}_1S at V_{IL} or E_2S at V_{IL} at the same time.

SRAM Write Enable (\overline{W}_S). The Write Enable input controls writing to the SRAM memory array. \overline{W}_S is active low.

SRAM Output Enable (\overline{G}_S). The Output Enable gates the outputs through the data buffers during a read operation of the SRAM memory. G_S is active low.

SRAM Upper Byte Enable (\overline{UB}_S). The Upper Byte Enable enables the upper bytes for SRAM (DQ8-DQ15). \overline{UB}_S is active low.

SRAM Lower Byte Enable (\overline{LB}_S). The Lower Byte Enable enables the lower bytes for SRAM (DQ0-DQ7). \overline{LB}_S is active low.

V_{DDF} and V_{DDs} Supply Voltages. V_{DDF} provides the power supply to the internal core of the Flash Memory device. It is the main power supply for all operations (Read, Program and Erase).

V_{DDQF} and V_{DDs} Supply Voltage (2.7V to 3.3V). V_{DDQF} provides the power supply for the Flash memory I/O pins and V_{DDs} provides the power supply for the SRAM control pins. This allows all Outputs to be powered independently of the Flash core power supply, V_{DDF} . V_{DDQF} can be tied to V_{DDs} .

V_{PPF} Program Supply Voltage. V_{PPF} is both a control input and a power supply pin for the Flash memory. The two functions are selected by the voltage range applied to the pin. The Supply Voltage V_{DDF} and the Program Supply Voltage V_{PPF} can be applied in any order.

If V_{PPF} is kept in a low voltage range (0V to 3.6V) V_{PPF} is seen as a control input. In this case a voltage lower than V_{PPLK} gives an absolute protection against program or erase, while $V_{PPF} > V_{PP1}$ enables these functions (see Table 6, DC Characteristics for the relevant values). V_{PPF} is only sampled at the beginning of a program or erase; a change in its value after the operation has started does not have any effect and program or erase operations continue.

If V_{PPF} is in the range 11.4V to 12.6V it acts as a power supply pin. In this condition V_{PPF} must be stable until the Program/Erase algorithm is completed (see Table 19 and 20).

V_{SSF} and V_{SSS} Ground. V_{SSF} and V_{SSS} are the ground reference for all voltage measurements in the Flash and SRAM chips, respectively.

Note: Each device in a system should have V_{DDF}, V_{DDQF} and V_{PPF} decoupled with a 0.1µF capacitor close to the pin. See Figure 9, AC Measurement Load Circuit. The PCB trace widths should be sufficient to carry the required V_{PPF} program and erase currents.

simultaneous read operations on the Flash and the SRAM which would result in a data bus contention. Therefore it is recommended to put the SRAM in the high impedance state when reading the Flash and vice versa (see Table 2 Main Operation Modes for details).

FUNCTIONAL DESCRIPTION

The Flash and SRAM components have separate power supplies and grounds and are distinguished by three chip enable inputs: \overline{E}_F for the Flash memory and \overline{E}_{1S} and \overline{E}_{2S} for the SRAM.

Recommended operating conditions do not allow both the Flash and the SRAM to be in active mode at the same time. The most common example is

Figure 4. Functional Block Diagram

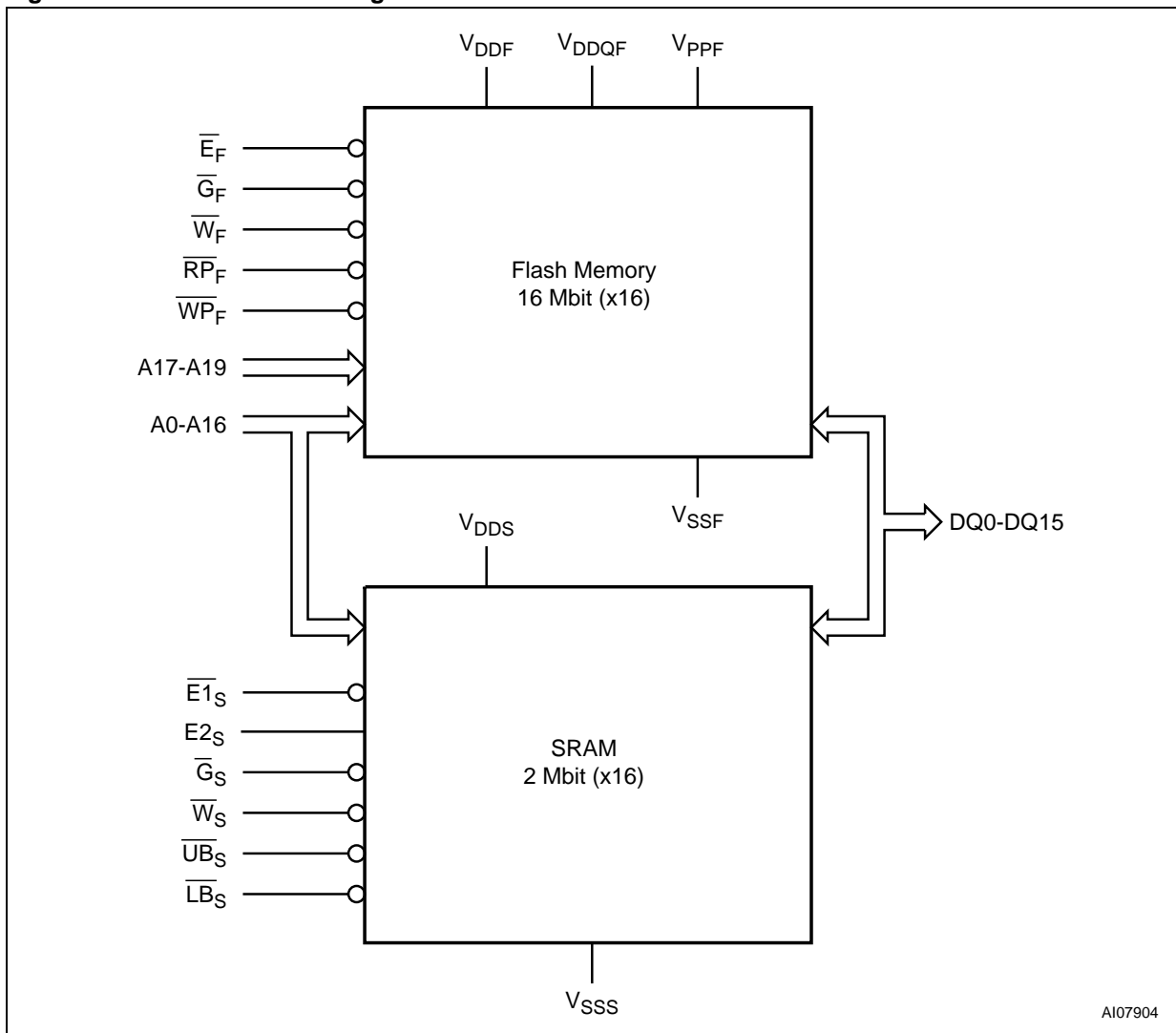

Table 2. Main Operation Modes

Operation Mode	\overline{E}_F	\overline{G}_F	\overline{W}_F	\overline{R}_F	\overline{P}_F	V _{PPF}	\overline{E}_{1s}	E _{2s}	\overline{G}_s	\overline{W}_s	\overline{U}_B_s	\overline{L}_B_s	DQ7-DQ0	DQ15-DQ8	
Flash Memory	Read	V _{IL}	V _{IL}	V _{IH}	V _{IH}	X	Don't care						SRAM must be disabled		Data Output
	Write	V _{IL}	V _{IH}	V _{IL}	V _{IH}	X	V _{DDF} or V _{PPFH}						SRAM must be disabled		Data Input
	Block Locking	V _{IL}	X	X	V _{IH}	V _{IL}	Don't care						SRAM must be disabled		X
	Standby	V _{IH}	X	X	V _{IH}	X	Don't care						Any SRAM mode is allowed		Hi-Z
	Reset	X	X	X	V _{IL}	X	Don't care						Any SRAM mode is allowed		Hi-Z
	Output Disable	V _{IL}	V _{IH}	V _{IH}	V _{IH}	X	Don't care						Any SRAM mode is allowed		Hi-Z
SRAM	Read	Flash must be disabled					V _{IL}	V _{IH}	V _{IL}	V _{IH}	V _{IL}	V _{IL}	Data out Word Read		
		Flash must be disabled					V _{IL}	V _{IH}	V _{IL}	V _{IH}	V _{IH}	V _{IL}	Data out	Hi-Z	
		Flash must be disabled					V _{IL}	V _{IH}	V _{IL}	V _{IH}	V _{IL}	V _{IH}	Hi-Z	Data out	
	Write	Flash must be disabled					V _{IL}	V _{IH}	X	V _{IL}	V _{IL}	V _{IL}	Data in Word Write		
		Flash must be disabled					V _{IL}	V _{IH}	X	V _{IL}	V _{IH}	V _{IL}	Data in	Hi-Z	
		Flash must be disabled					V _{IL}	V _{IH}	X	V _{IL}	V _{IL}	V _{IH}	Hi-Z	Data in	
	Standby/ Power Down	Any Flash mode is allowable					V _{IH}	V _{IL}	X	X	X	X	Hi-Z		
		Any Flash mode is allowable					X	X	X	X	V _{IH}	V _{IH}	Hi-Z		
	Data Retention	Any Flash mode is allowable					V _{IH}	V _{IL}	X	X	X	X	Hi-Z		
		Any Flash mode is allowable					X	X	X	X	V _{IH}	V _{IH}	Hi-Z		
	Output Disable	Any Flash mode is allowable					V _{IL}	V _{IH}	V _{IH}	V _{IH}	V _{IL}	V _{IL}	Hi-Z		
		Any Flash mode is allowable					V _{IL}	V _{IH}	V _{IH}	V _{IH}	V _{IH}	V _{IL}	Hi-Z		
Any Flash mode is allowable					V _{IL}	V _{IH}	V _{IH}	V _{IH}	V _{IL}	V _{IH}	Hi-Z				

Note: X = Don't care = V_{IL} or V_{IH}, V_{PPFH} = 12V ± 5%.

MAXIMUM RATING

Stressing the device above the rating listed in the Absolute Maximum Ratings table may cause permanent damage to the device. These are stress ratings only and operation of the device at these or any other conditions above those indicated in the Operating sections of this specification is not im-

plied. Exposure to Absolute Maximum Rating conditions for extended periods may affect device reliability. Refer also to the STMicroelectronics SURE Program and other relevant quality documents.

Table 3. Absolute Maximum Ratings

Symbol	Parameter	Value		Unit
		Min	Max	
T_A	Ambient Operating Temperature ⁽¹⁾	-40	85	°C
T_{BIAS}	Temperature Under Bias	-40	125	°C
T_{STG}	Storage Temperature	-55	150	°C
V_{IO}	Input or Output Voltage	-0.5	$V_{DDQF} + 0.5$	V
V_{DDF} , V_{DDQF}	Flash Supply Voltage	-0.5	3.8	V
V_{PPF}	Program Voltage	-0.6	13	V
V_{DDS}	SRAM Supply Voltage	-0.5	3.8	V

Note: 1. Depends on range.

DC AND AC PARAMETERS

This section summarizes the operating and measurement conditions, and the DC and AC characteristics of the device. The parameters in the DC and AC characteristics Tables that follow, are derived from tests performed under the Measure-

ment Conditions summarized in Table 4, Operating and AC Measurement Conditions. Designers should check that the operating conditions in their circuit match the measurement conditions when relying on the quoted parameters.

Table 4. Operating and AC Measurement Conditions

Parameter	SRAM		Flash Memory		Units
	70		70/85		
	Min	Max	Min	Max	
V _{DDF} Supply Voltage	–	–	2.7	3.3	V
V _{DDQF} Supply Voltage	–	–	2.7	3.3	V
V _{DDS} Supply Voltage	2.7	3.3	–	–	V
Ambient Operating Temperature	– 40	85	– 40	85	°C
Load Capacitance (C _L)	30		50		pF
Input Rise and Fall Times			1V/ns	5ns	
Input Pulse Voltages	0 to V _{DDQF}		0 to V _{DDQF}		V
Input and Output Timing Ref. Voltages	V _{DDQF} /2		V _{DDQF} /2		V

Figure 5. AC Measurement I/O Waveform

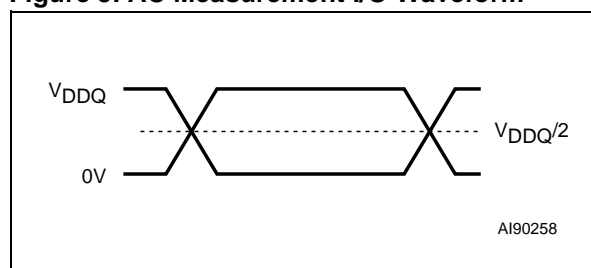

Note: V_{DDQ} means V_{DDQF} = V_{DDS}

Figure 6. AC Measurement Load Circuit

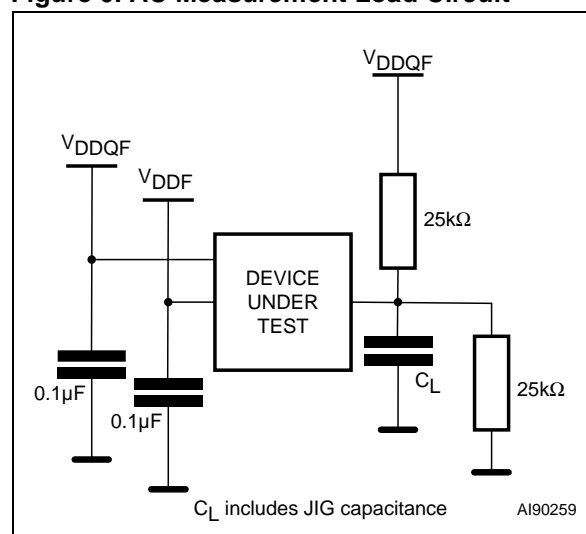

Table 5. Device Capacitance

Symbol	Parameter	Test Condition	Typ	Max	Unit
C _{IN}	Input Capacitance	V _{IN} = 0V, f=1 MHz		12	pF
C _{OUT}	Output Capacitance	V _{OUT} = 0V, f=1 MHz		15	pF

Note: Sampled only, not 100% tested.

Table 6. DC Characteristics

Symbol	Parameter	Device	Test Condition	Min	Typ	Max	Unit
I_{LI}	Input Leakage Current	Flash & SRAM	$0V \leq V_{IN} \leq V_{DDQF}$			± 1	μA
I_{LO}	Output Leakage Current	Flash	$0V \leq V_{OUT} \leq V_{DDQF}$			± 10	μA
		SRAM	$0V \leq V_{OUT} \leq V_{DDQF}$, SRAM Outputs Hi-Z			± 1	μA
I_{DDs}	V_{DD} Standby Current	Flash	$\bar{E}_F = V_{DDQF} \pm 0.2V$ $\overline{RP}_F = V_{DDQ} \pm 0.2V$		15	50	μA
		SRAM	$\bar{E}T_S \geq V_{DDs} - 0.2V$ $V_{IN} \geq V_{DDs} - 0.2V$ or $V_{IN} \leq 0.2V$		5	15	μA
I_{DDd}	Supply Current (Reset)	Flash	$\overline{RP}_F = V_{SSF} \pm 0.2V$		15	50	μA
I_{DD}	Supply Current	SRAM	$V_{DDs} = 3.3V$, $I_{OUT} = 0 \text{ mA}$, $f = 1 \text{ MHz}$		1.5	3	mA
			$V_{DDs} = 3.3V$, $I_{OUT} = 0 \text{ mA}$, $f = f_{MAX} = 1/t_{AVAV}$		7	15	mA
I_{DDR}	Supply Current (Read)	Flash	$\bar{E}_F = V_{IL}$, $\bar{G}_F = V_{IH}$, $f = 5 \text{ MHz}$		10	20	mA
I_{DDW}	Supply Current (Program)	Flash	Program in progress $V_{PPF} = 12V \pm 5\%$		10	20	mA
			Program in progress $V_{PPF} = V_{DDF}$		10	20	mA
I_{DDE}	Supply Current (Erase)	Flash	Erase in progress $V_{PPF} = 12V \pm 5\%$		5	20	mA
			Erase in progress $V_{PPF} = V_{DDF}$		5	20	mA
I_{DDES}	Supply Current (Program/Erase Suspend)	Flash	$\bar{E}_F = V_{DDQF} \pm 0.2V$, Erase suspended			50	μA
I_{PP1}	Program Current (Read or Standby)	Flash	$V_{PPF} > V_{DDF}$			400	μA
I_{PP2}	Program Current (Read or Standby)	Flash	$V_{PPF} \leq V_{DDF}$			5	μA
I_{PPR}	Program Current (Reset)	Flash	$\overline{RP}_F = V_{SSF} \pm 0.2V$			5	μA
I_{PPW}	Program Current (Program)	Flash	$V_{PPF} = 12V \pm 0.5V$ Program in progress			10	mA
			$V_{PPF} = V_{DDF}$ Program in progress			5	mA
I_{PPE}	Program Current (Erase)	Flash	$V_{PPF} = 12V \pm 0.5V$ Erase in progress			10	mA
			$V_{PPF} = V_{DDF}$ Erase in progress			5	μA
V_{IL}	Input Low Voltage	Flash & SRAM	$V_{DDQF} = V_{DDs} \geq 2.7V$	-0.3		0.6	V
V_{IH}	Input High Voltage	Flash & SRAM	$V_{DDQF} = V_{DDs} \geq 2.7V$	$0.7V_{DDQF}$		$V_{DDQF} + 0.3$	V

M36W216TI, M36W216BI

Symbol	Parameter	Device	Test Condition	Min	Typ	Max	Unit
V _{OL}	Output Low Voltage	Flash & SRAM	$V_{DDQF} = V_{DD} = V_{DD} \text{ min}$ $I_{OL} = 100\mu\text{A}$			0.1	V
V _{OH}	Output High Voltage	Flash & SRAM	$V_{DDQF} = V_{DD} = V_{DD} \text{ min}$ $I_{OH} = -100\mu\text{A}$	V_{DDQ} -0.1			V
V _{PP1}	Program Voltage (Program or Erase operations)	Flash		1.65		3.6	V
V _{PPFH}	Program Voltage (Program or Erase operations)	Flash		11.4		12.6	V
V _{PPLK}	Program Voltage (Program and Erase lock-out)	Flash				1	V
V _{LKO}	V _{DDF} Supply Voltage (Program and Erase lock-out)	Flash				2	V

PACKAGE MECHANICAL

Figure 7. Stacked LFBGA66-12x8mm, 8x8 ball array, 0.8mm pitch, Bottom View Package Outline

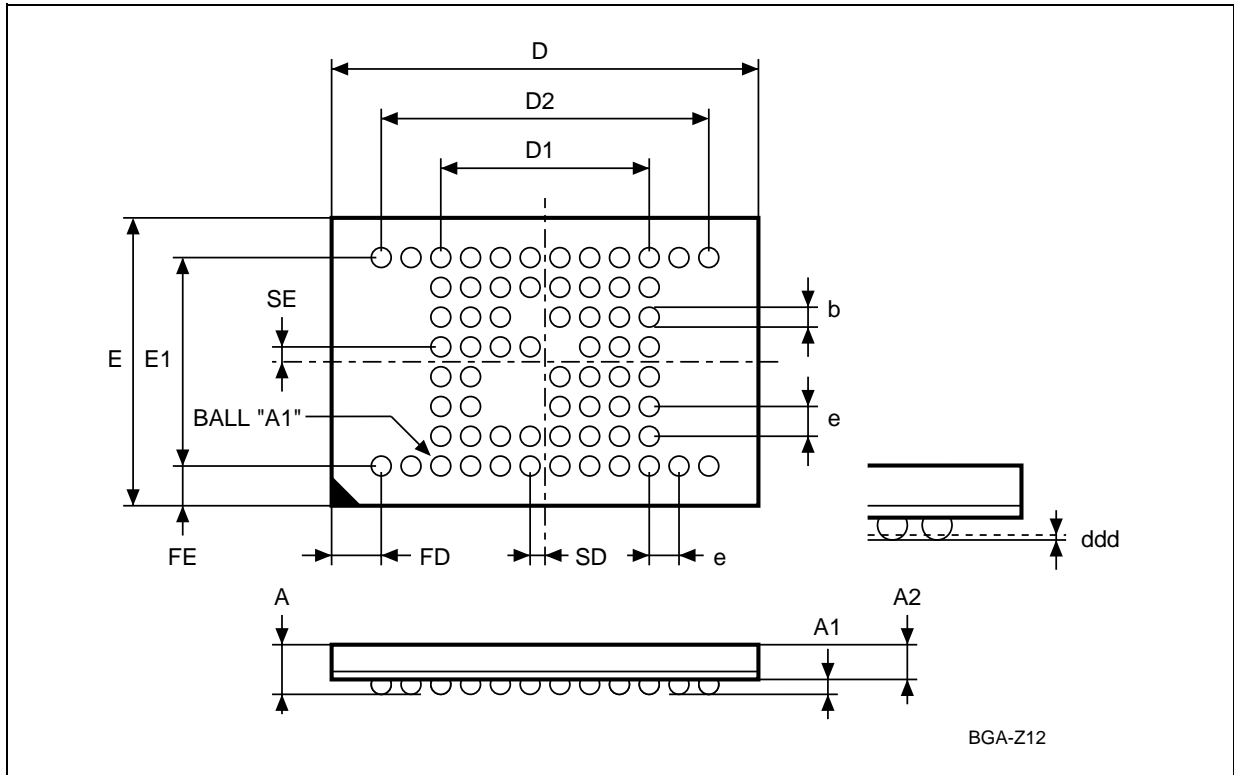

Note: Drawing is not to scale.

Table 7. Stacked LFBGA66 - 12x8mm, 8x8 ball array, 0.8 mm pitch, Package Mechanical Data

Symbol	millimeters			inches		
	Typ	Min	Max	Typ	Min	Max
A			1.400			0.0551
A1		0.300			0.0118	
A2			1.100			0.0433
b	0.400	0.300	0.500	0.0157	0.0118	0.0197
D	12.000	–	–	0.4724	–	–
D1	5.600	–	–	0.2205	–	–
D2	8.800	–	–	0.3465	–	–
ddd			0.100			0.0039
E	8.000	–	–	0.3150	–	–
E1	5.600	–	–	0.2205	–	–
e	0.800	–	–	0.0315	–	–
FD	1.600	–	–	0.0630	–	–
FE	1.200	–	–	0.0472	–	–
SD	0.400	–	–	0.0157	–	–
SE	0.400	–	–	0.0157	–	–

Figure 8. Stacked LFBGA66 Daisy Chain - Package Connections (Top view through package)

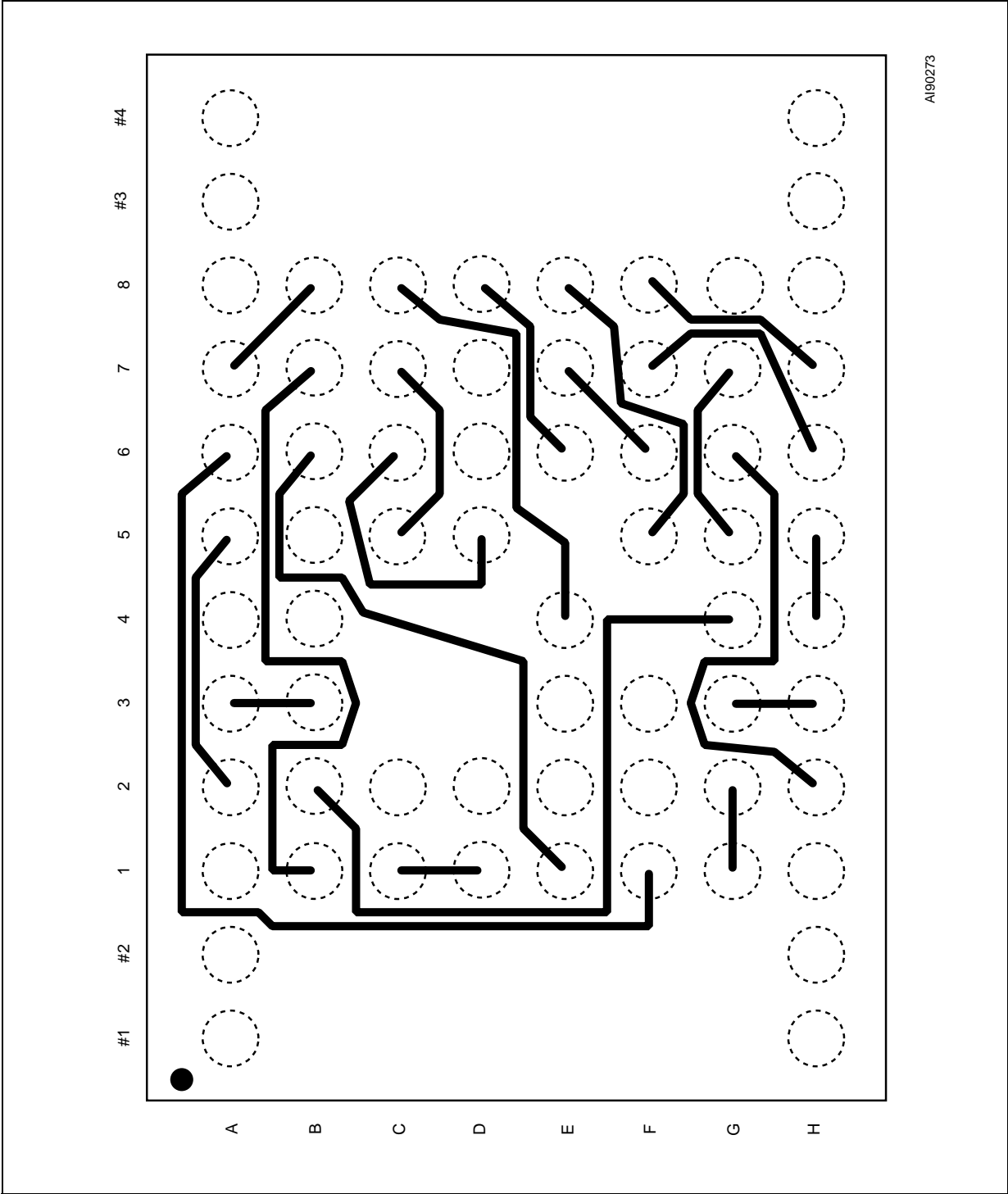
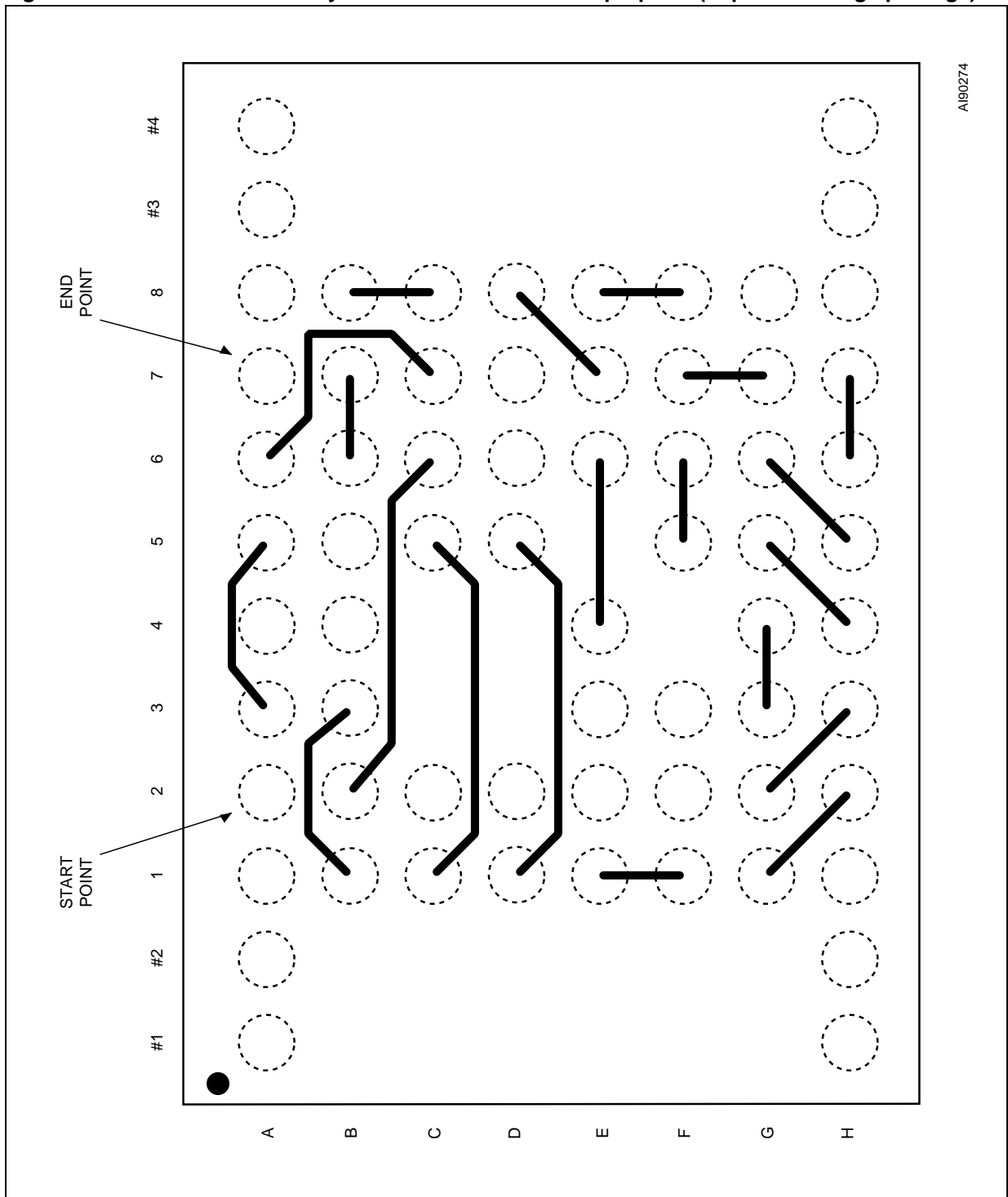
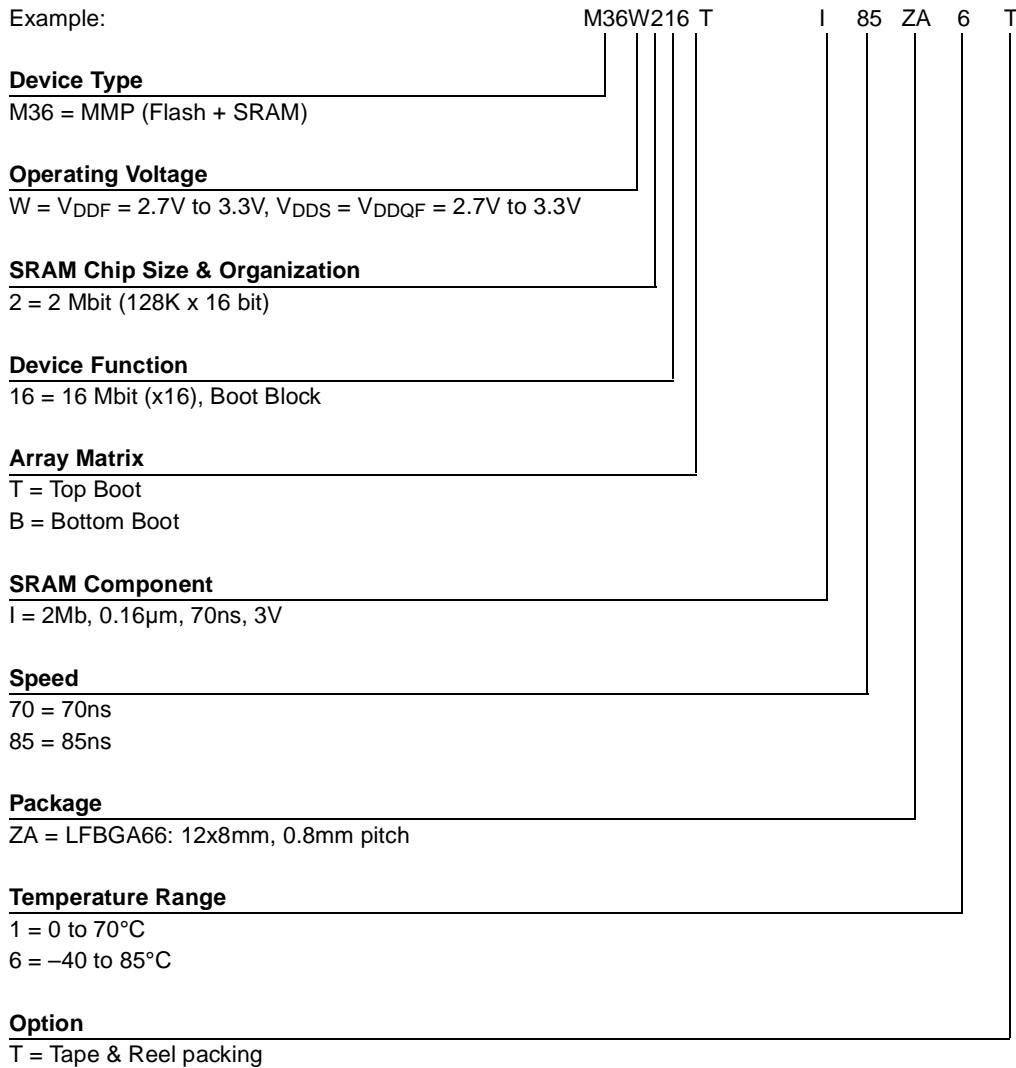

Figure 9. Stacked LFBGA66 Daisy Chain - PCB Connections proposal (Top view through package)



PART NUMBERING

Table 8. Ordering Information Scheme



Devices are shipped from the factory with the memory content bits erased to '1'.

Table 9. Daisy Chain Ordering Scheme

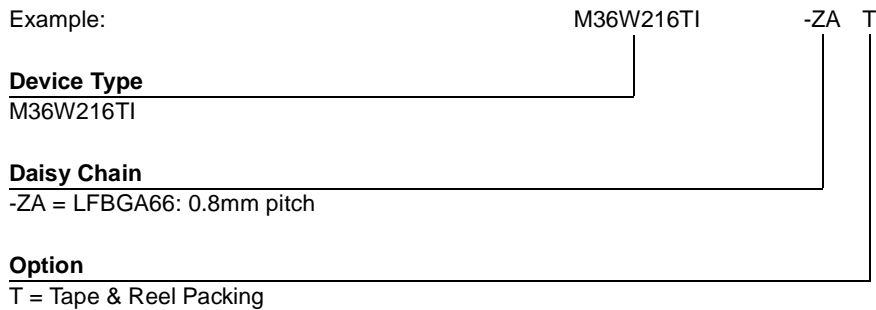

For a list of available options (Speed, Package, etc.) or for further information on any aspect of this device, please contact the STMicroelectronics Sales Office nearest to you.

FLASH DEVICE

The M36W216TI contains one 16 Mbit Flash memory. This section describes how to use the

Flash device and all signals refer to the Flash device.

FLASH SUMMARY DESCRIPTION

The Flash Memory is a 16 Mbit (1 Mbit x 16) non-volatile device that can be erased electrically at the block level and programmed in-system on a Word-by-Word basis. These operations can be performed using a single low voltage (2.7 to 3.6V) supply. V_{DDQF} is used to drive the I/O pin down to 1.65V. An optional 12V V_{PPF} power supply is provided to speed up customer programming.

The device features an asymmetrical blocked architecture with an array of 39 blocks: 8 Parameter Blocks of 4 KWords and 31 Main Blocks of 32 KWords. The M36W216TI has the Parameter Blocks at the top of the memory address space while the M36W216BI locates the Parameter Blocks starting from the bottom. The memory maps are shown in Figure 10, Block Addresses.

The Flash Memory features an instant, individual block locking scheme that allows any block to be locked or unlocked with no latency, enabling instant code and data protection. All blocks have three levels of protection. They can be locked and locked-down individually preventing any accidental programming or erasure. There is an additional hardware protection against program and erase. When $V_{PPF} \leq V_{PPLK}$ all blocks are protected against program or erase. All blocks are locked at Power Up.

Each block can be erased separately. Erase can be suspended in order to perform either read or program in any other block and then resumed. Program can be suspended to read data in any other block and then resumed. Each block can be programmed and erased over 100,000 cycles.

The device includes a 128 bit Protection Register and a Security Block to increase the protection of a system design. The Protection Register is divided into two 64 bit segments, the first one contains a unique device number written by ST, while the second one is one-time-programmable by the user. The user programmable segment can be permanently protected. The Security Block, parameter block 0, can be permanently protected by the user. Figure 11, shows the Flash Security Block Memory Map.

Program and Erase commands are written to the Command Interface of the memory. An on-chip Program/Erase Controller takes care of the timings necessary for program and erase operations. The end of a program or erase operation can be detected and any error conditions identified. The command set required to control the memory is consistent with JEDEC standards.

FLASH BUS OPERATIONS

There are six standard bus operations that control the device. These are Bus Read, Bus Write, Output Disable, Standby, Automatic Standby and Reset. See Table 2, Main Operation Modes, for a summary.

Typically glitches of less than 5ns on Chip Enable or Write Enable are ignored by the memory and do not affect bus operations.

Read. Read Bus operations are used to output the contents of the Memory Array, the Electronic Signature, the Status Register and the Common Flash Interface. Both Chip Enable and Output Enable must be at V_{IL} in order to perform a read operation. The Chip Enable input should be used to enable the device. Output Enable should be used to gate data onto the output. The data read depends on the previous command written to the memory (see Command Interface section). See Figure 12, Flash Read Mode AC Waveforms, and Table 18, Flash Read AC Characteristics, for details of when the output becomes valid.

Read mode is the default state of the device when exiting Reset or after power-up.

Write. Bus Write operations write Commands to the memory or latch Input Data to be programmed. A write operation is initiated when Chip Enable and Write Enable are at V_{IL} with Output Enable at V_{IH} . Commands, Input Data and Addresses are latched on the rising edge of Write Enable or Chip Enable, whichever occurs first.

See Figures 13 and 14, Flash Write AC Waveforms, and Tables 19 and 20, Flash Write AC

Characteristics, for details of the timing requirements.

Output Disable. The data outputs are high impedance when the Output Enable is at V_{IH} .

Standby. Standby disables most of the internal circuitry allowing a substantial reduction of the current consumption. The memory is in stand-by when Chip Enable is at V_{IH} and the device is in read mode. The power consumption is reduced to the stand-by level and the outputs are set to high impedance, independently from the Output Enable or Write Enable inputs. If Chip Enable switches to V_{IH} during a program or erase operation, the device enters Standby mode when finished.

Automatic Standby. Automatic Standby provides a low power consumption state during Read mode. Following a read operation, the device enters Automatic Standby after 150ns of bus inactivity even if Chip Enable is Low, V_{IL} , and the supply current is reduced to I_{DD1} . The data Inputs/Outputs will still output data if a bus Read operation is in progress.

Reset. During Reset mode when Output Enable is Low, V_{IL} , the memory is deselected and the outputs are high impedance. The memory is in Reset mode when Reset is at V_{IL} . The power consumption is reduced to the Standby level, independently from the Chip Enable, Output Enable or Write Enable inputs. If Reset is pulled to V_{SS} during a Program or Erase, this operation is aborted and the memory content is no longer valid.

FLASH COMMAND INTERFACE

All Bus Write operations to the memory are interpreted by the Command Interface. Commands consist of one or more sequential Bus Write operations. An internal Program/Erase Controller handles all timings and verifies the correct execution of the Program and Erase commands. The Program/Erase Controller provides a Status Register whose output may be read at any time during, to monitor the progress of the operation, or the Program/Erase states. See Appendix 29, Table 33, Write State Machine Current/Next, for a summary of the Command Interface.

The Command Interface is reset to Read mode when power is first applied, when exiting from Reset or whenever V_{DD} is lower than V_{LKO} . Command sequences must be followed exactly. Any invalid combination of commands will reset the device to Read mode. Refer to Table 10, Commands, in conjunction with the text descriptions below.

Read Memory Array Command

The Read command returns the memory to its Read mode. One Bus Write cycle is required to issue the Read Memory Array command and return the memory to Read mode. Subsequent read operations will read the addressed location and output the data. When a device Reset occurs, the memory defaults to Read mode.

Read Status Register Command

The Status Register indicates when a program or erase operation is complete and the success or failure of the operation itself. Issue a Read Status Register command to read the Status Register's contents. Subsequent Bus Read operations read the Status Register at any address, until another command is issued. See Table 17, Status Register Bits, for details on the definitions of the bits.

The Read Status Register command may be issued at any time, even during a Program/Erase operation. Any Read attempt during a Program/Erase operation will automatically output the content of the Status Register.

Read Electronic Signature Command

The Read Electronic Signature command reads the Manufacturer and Device Codes and the Block Locking Status, or the Protection Register.

The Read Electronic Signature command consists of one write cycle, a subsequent read will output the Manufacturer Code, the Device Code, the Block Lock and Lock-Down Status, or the Protection and Lock Register. See Tables 11, 12 and 13 for the valid address.

Read CFI Query Command

The Read Query Command is used to read data from the Common Flash Interface (CFI) Memory

Area, allowing programming equipment or applications to automatically match their interface to the characteristics of the device. One Bus Write cycle is required to issue the Read Query Command. Once the command is issued subsequent Bus Read operations read from the Common Flash Interface Memory Area. See Appendix B, Common Flash Interface, Tables 27, 28, 29, 30, 31 and 32 for details on the information contained in the Common Flash Interface memory area.

Block Erase Command

The Block Erase command can be used to erase a block. It sets all the bits within the selected block to '1'. All previous data in the block is lost. If the block is protected then the Erase operation will abort, the data in the block will not be changed and the Status Register will output the error.

Two Bus Write cycles are required to issue the command.

- The first bus cycle sets up the Erase command.
- The second latches the block address in the internal state machine and starts the Program/Erase Controller.

If the second bus cycle is not Write Erase Confirm (D0h), Status Register bits b4 and b5 are set and the command aborts.

Erase aborts if Reset turns to V_{IL} . As data integrity cannot be guaranteed when the Erase operation is aborted, the block must be erased again.

During Erase operations the memory will accept the Read Status Register command and the Program/Erase Suspend command, all other commands will be ignored. Typical Erase times are given in Table 14, Program, Erase Times and Program/Erase Endurance Cycles.

See Appendix C, Figure 28, Erase Flowchart and Pseudo Code, for a suggested flowchart for using the Erase command.

Program Command

The memory array can be programmed word-by-word. Two bus write cycles are required to issue the Program Command.

- The first bus cycle sets up the Program command.
- The second latches the Address and the Data to be written and starts the Program/Erase Controller.

During Program operations the memory will accept the Read Status Register command and the Program/Erase Suspend command. Typical Program times are given in Table 14, Program, Erase Times and Program/Erase Endurance Cycles.

Programming aborts if Reset goes to V_{IL} . As data integrity cannot be guaranteed when the program

operation is aborted, the block containing the memory location must be erased and reprogrammed.

See Appendix C, Figure 25, Program Flowchart and Pseudo Code, for the flowchart for using the Program command.

Double Word Program Command

This feature is offered to improve the programming throughput, writing a page of two adjacent words in parallel. The two words must differ only for the address A0. Programming should not be attempted when V_{PP} is not at V_{PPFH} . The command can be executed if V_{PP} is below V_{PPFH} but the result is not guaranteed.

Three bus write cycles are necessary to issue the Double Word Program command.

- The first bus cycle sets up the Double Word Program Command.
- The second bus cycle latches the Address and the Data of the first word to be written.
- The third bus cycle latches the Address and the Data of the second word to be written and starts the Program/Erase Controller.

Read operations output the Status Register content after the programming has started. Programming aborts if Reset goes to V_{IL} . As data integrity cannot be guaranteed when the program operation is aborted, the block containing the memory location must be erased and reprogrammed.

See Appendix C, Figure 26, Double Word Program Flowchart and Pseudo Code, for the flowchart for using the Double Word Program command.

Clear Status Register Command

The Clear Status Register command can be used to reset bits 1, 3, 4 and 5 in the Status Register to '0'. One bus write cycle is required to issue the Clear Status Register command.

The bits in the Status Register do not automatically return to '0' when a new Program or Erase command is issued. The error bits in the Status Register should be cleared before attempting a new Program or Erase command.

Program/Erase Suspend Command

The Program/Erase Suspend command is used to pause a Program or Erase operation. One bus write cycle is required to issue the Program/Erase command and pause the Program/Erase controller.

During Program/Erase Suspend the Command Interface will accept the Program/Erase Resume, Read Array, Read Status Register, Read Electronic Signature and Read CFI Query commands. Additionally, if the suspend operation was Erase then the Program, Block Lock, Block Lock-Down or

Protection Program commands will also be accepted. The block being erased may be protected by issuing the Block Protect, Block Lock or Protection Program commands. When the Program/Erase Resume command is issued the operation will complete. Only the blocks not being erased may be read or programmed correctly.

During a Program/Erase Suspend, the device can be placed in a pseudo-standby mode by taking Chip Enable to V_{IH} . Program/Erase is aborted if Reset turns to V_{IL} .

See Appendix C, Figure 27, Program Suspend & Resume Flowchart and Pseudo Code, and Figure 29, Erase Suspend & Resume Flowchart and Pseudo Code for flowcharts for using the Program/Erase Suspend command.

Program/Erase Resume Command

The Program/Erase Resume command can be used to restart the Program/Erase Controller after a Program/Erase Suspend operation has paused it. One Bus Write cycle is required to issue the command. Once the command is issued subsequent Bus Read operations read the Status Register.

See Appendix C, Figure 27, Program Suspend & Resume Flowchart and Pseudo Code, and Figure 29, Erase Suspend & Resume Flowchart and Pseudo Code for flowcharts for using the Program/Erase Resume command.

Protection Register Program Command

The Protection Register Program command is used to Program the 64 bit user One-Time-Programmable (OTP) segment of the Protection Register. The segment is programmed 16 bits at a time. When shipped all bits in the segment are set to '1'. The user can only program the bits to '0'.

Two write cycles are required to issue the Protection Register Program command.

- The first bus cycle sets up the Protection Register Program command.
- The second latches the Address and the Data to be written to the Protection Register and starts the Program/Erase Controller.

Read operations output the Status Register content after the programming has started.

The segment can be protected by programming bit 1 of the Protection Lock Register. Bit 1 of the Protection Lock Register protects bit 2 of the Protection Lock Register. Programming bit 2 of the Protection Lock Register will result in a permanent protection of the Security Block (see Figure 11, Flash Security Block and Protection Register Memory Map). Attempting to program a previously protected Protection Register will result in a Status Register error. The protection of the Protection

Register and/or the Security Block is not reversible.

The Protection Register Program cannot be suspended. See Appendix C, Figure 31, Protection Register Program Flowchart and Pseudo Code, for the flowchart for using the Protection Register Program command.

Block Lock Command

The Block Lock command is used to lock a block and prevent Program or Erase operations from changing the data in it. All blocks are locked at power-up or reset.

Two Bus Write cycles are required to issue the Block Lock command.

- The first bus cycle sets up the Block Lock command.
- The second Bus Write cycle latches the block address.

The lock status can be monitored for each block using the Read Electronic Signature command. Table. 16 shows the protection status after issuing a Block Lock command.

The Block Lock bits are volatile, once set they remain set until a hardware reset or power-down/power-up. They are cleared by a Blocks Unlock command. Refer to the section, Block Locking, for a detailed explanation.

Block Unlock Command

The Blocks Unlock command is used to unlock a block, allowing the block to be programmed or

erased. Two Bus Write cycles are required to issue the Blocks Unlock command.

- The first bus cycle sets up the Block Unlock command.
- The second Bus Write cycle latches the block address.

The lock status can be monitored for each block using the Read Electronic Signature command. Table. 16 shows the protection status after issuing a Block Unlock command. Refer to the section, Block Locking, for a detailed explanation.

Block Lock-Down Command

A locked block cannot be Programmed or Erased, or have its protection status changed when \overline{WP}_F is low, V_{IL} . When \overline{WP}_F is high, V_{IH} , the Lock-Down function is disabled and the locked blocks can be individually unlocked by the Block Unlock command.

Two Bus Write cycles are required to issue the Block Lock-Down command.

- The first bus cycle sets up the Block Lock command.
- The second Bus Write cycle latches the block address.

The lock status can be monitored for each block using the Read Electronic Signature command. Locked-Down blocks revert to the locked (and not locked-down) state when the device is reset on power-down. Table. 16 shows the protection status after issuing a Block Lock-Down command. Refer to the section, Block Locking, for a detailed explanation.

Table 10. Flash Commands

Commands	No. of Cycles	Bus Write Operations								
		1st Cycle			2nd Cycle			3rd Cycle		
		Bus Op.	Addr	Data	Bus Op.	Addr	Data	Bus Op.	Addr	Data
Read Memory Array	1+	Write	X	FFh	Read	Read Addr	Data			
Read Status Register	1+	Write	X	70h	Read	X	Status Register			
Read Electronic Signature	1+	Write	X	90h	Read	Signature Addr (2)	Signature			
Read CFI Query	1+	Write	X	98h	Read	CFI Addr	Query			
Erase	2	Write	X	20h	Write	Block Addr	D0h			
Program	2	Write	X	40h or 10h	Write	Addr	Data Input			
Double Word Program ⁽³⁾	3	Write	X	30h	Write	Addr 1	Data Input	Write	Addr 2	Data Input
Clear Status Register	1	Write	X	50h						
Program/Erase Suspend	1	Write	X	B0h						
Program/Erase Resume	1	Write	X	D0h						
Block Lock	2	Write	X	60h	Write	Block Address	01h			
Block Unlock	2	Write	X	60h	Write	Block Address	D0h			
Block Lock-Down	2	Write	X	60h	Write	Block Address	2Fh			
Protection Register Program	2	Write	X	C0h	Write	Address	Data Input			

Note: 1. X = Don't Care.

2. The signature addresses are listed in Tables 11, 12 and 13.

3. Addr 1 and Addr 2 must be consecutive Addresses differing only for A0.

Table 11. Read Electronic Signature

Code	Device	\bar{E}_F	\bar{G}_F	\bar{W}_F	A0	A1	A2-A7	A8-A19	DQ0-DQ7	DQ8-DQ15
Manufacture. Code		V _{IL}	V _{IL}	V _{IH}	V _{IL}	V _{IL}	0	Don't Care	20h	00h
Device Code	M36W216TI	V _{IL}	V _{IL}	V _{IH}	V _{IH}	V _{IL}	0	Don't Care	CEh	88h
	M36W216BI	V _{IL}	V _{IL}	V _{IH}	V _{IH}	V _{IL}	0	Don't Care	CFh	88h

Note: $RP_F = V_{IH}$.

Table 12. Read Block Lock Signature

Block Status	\bar{E}_F	\bar{G}_F	\bar{W}_F	A0	A1	A2-A7	A8-A11	A12-A19	DQ0	DQ1	DQ2-DQ15
Locked Block	V _{IL}	V _{IL}	V _{IH}	V _{IL}	V _{IH}	0	Don't Care	Block Address	1	0	00h
Unlocked Block	V _{IL}	V _{IL}	V _{IH}	V _{IL}	V _{IH}	0	Don't Care	Block Address	0	0	00h
Locked-Down Block	V _{IL}	V _{IL}	V _{IH}	V _{IL}	V _{IH}	0	Don't Care	Block Address	X ⁽¹⁾	1	00h

Note: 1. A Locked-Down Block can be locked "DQ0 = 1" or unlocked "DQ0 = 0"; see Block Locking section.

Table 13. Read Protection Register and Lock Register

Word	\bar{E}_F	\bar{G}_F	\bar{W}_F	A0-A7	A8-A19	DQ0	DQ1	DQ2	DQ3-DQ7	DQ8-DQ15
Lock	V _{IL}	V _{IL}	V _{IH}	80h	Don't Care	0	OTP Prot. data	Security prot. data	00h	00h
Unique ID 0	V _{IL}	V _{IL}	V _{IH}	81h	Don't Care	ID data	ID data	ID data	ID data	ID data
Unique ID 1	V _{IL}	V _{IL}	V _{IH}	82h	Don't Care	ID data	ID data	ID data	ID data	ID data
Unique ID 2	V _{IL}	V _{IL}	V _{IH}	83h	Don't Care	ID data	ID data	ID data	ID data	ID data
Unique ID 3	V _{IL}	V _{IL}	V _{IH}	84h	Don't Care	ID data	ID data	ID data	ID data	ID data
OTP 0	V _{IL}	V _{IL}	V _{IH}	85h	Don't Care	OTP data	OTP data	OTP data	OTP data	OTP data
OTP 1	V _{IL}	V _{IL}	V _{IH}	86h	Don't Care	OTP data	OTP data	OTP data	OTP data	OTP data
OTP 2	V _{IL}	V _{IL}	V _{IH}	87h	Don't Care	OTP data	OTP data	OTP data	OTP data	OTP data
OTP 3	V _{IL}	V _{IL}	V _{IH}	88h	Don't Care	OTP data	OTP data	OTP data	OTP data	OTP data

Table 14. Program, Erase Times and Program/Erase Endurance Cycles

Parameter	Test Conditions	M36W216TI			Unit
		Min	Typ	Max	
Word Program	V _{PP} = V _{DD}		10	200	μs
Double Word Program	V _{PP} = 12V ±5%		10	200	μs
Main Block Program	V _{PP} = 12V ±5%		0.16	5	s
	V _{PP} = V _{DD}		0.32	5	s
Parameter Block Program	V _{PP} = 12V ±5%		0.02	4	s
	V _{PP} = V _{DD}		0.04	4	s
Main Block Erase	V _{PP} = 12V ±5%		1	10	s
	V _{PP} = V _{DD}		1	10	s
Parameter Block Erase	V _{PP} = 12V ±5%		0.8	10	s
	V _{PP} = V _{DD}		0.8	10	s
Program/Erase Cycles (per Block)		100,000			cycles

FLASH BLOCK LOCKING

The Flash memory features an instant, individual block locking scheme that allows any block to be locked or unlocked with no latency. This locking scheme has three levels of protection.

- Lock/Unlock - this first level allows software-only control of block locking.
- Lock-Down - this second level requires hardware interaction before locking can be changed.
- $V_{PP} \leq V_{PPLK}$ - the third level offers a complete hardware protection against program and erase on all blocks.

The lock status of each block can be set to Locked, Unlocked, and Lock-Down. Table 16, defines all of the possible protection states (\overline{WPF} , DQ1, DQ0), and Appendix C, Figure 30, shows a flowchart for the locking operations.

Reading a Block's Lock Status

The lock status of every block can be read in the Read Electronic Signature mode of the device. To enter this mode write 90h to the device. Subsequent reads at the address specified in Table 12, will output the lock status of that block. The lock status is represented by DQ0 and DQ1. DQ0 indicates the Block Lock/Unlock status and is set by the Lock command and cleared by the Unlock command. It is also automatically set when entering Lock-Down. DQ1 indicates the Lock-Down status and is set by the Lock-Down command. It cannot be cleared by software, only by a hardware reset or power-down.

The following sections explain the operation of the locking system.

Locked State

The default status of all blocks on power-up or after a hardware reset is Locked (states (0,0,1) or (1,0,1)). Locked blocks are fully protected from any program or erase. Any program or erase operations attempted on a locked block will return an error in the Status Register. The Status of a Locked block can be changed to Unlocked or Lock-Down using the appropriate software commands. An Unlocked block can be Locked by issuing the Lock command.

Unlocked State

Unlocked blocks (states (0,0,0), (1,0,0) (1,1,0)), can be programmed or erased. All unlocked blocks return to the Locked state after a hardware reset or when the device is powered-down. The status of an unlocked block can be changed to Locked or Locked-Down using the appropriate

software commands. A locked block can be unlocked by issuing the Unlock command.

Lock-Down State

Blocks that are Locked-Down (state (0,1,x)) are protected from program and erase operations (as for Locked blocks) but their lock status cannot be changed using software commands alone. A Locked or Unlocked block can be Locked-Down by issuing the Lock-Down command. Locked-Down blocks revert to the Locked state when the device is reset or powered-down.

The Lock-Down function is dependent on the \overline{WPF} input pin. When $\overline{WPF}=0$ (V_{IL}), the blocks in the Lock-Down state (0,1,x) are protected from program, erase and protection status changes. When $\overline{WPF}=1$ (V_{IH}) the Lock-Down function is disabled (1,1,1) and Locked-Down blocks can be individually unlocked to the (1,1,0) state by issuing the software command, where they can be erased and programmed. These blocks can then be relocked (1,1,1) and unlocked (1,1,0) as desired while \overline{WPF} remains high. When \overline{WPF} is low, blocks that were previously Locked-Down return to the Lock-Down state (0,1,x) regardless of any changes made while \overline{WPF} was high. Device reset or power-down resets all blocks, including those in Lock-Down, to the Locked state.

Locking Operations During Erase Suspend

Changes to block lock status can be performed during an erase suspend by using the standard locking command sequences to unlock, lock or lock-down a block. This is useful in the case when another block needs to be updated while an erase operation is in progress.

To change block locking during an erase operation, first write the Erase Suspend command, then check the status register until it indicates that the erase operation has been suspended. Next write the desired Lock command sequence to a block and the protection status will be changed. After completing any desired lock, read, or program operations, resume the erase operation with the Erase Resume command.

If a block is locked or locked-down during an erase suspend of the same block, the locking status bits will be changed immediately, but when the erase is resumed, the erase operation will complete.

Locking operations cannot be performed during a program suspend. Refer to Appendix D, Command Interface and Program/Erase Controller State, for detailed information on which commands are valid during erase suspend.

Table 15. Block Lock Status

Item	Address	Data
Block Lock Configuration	xx002	LOCK
Block is Unlocked		DQ0=0
Block is Locked		DQ0=1
Block is Locked-Down		DQ1=1

Table 16. Protection Status

Current Protection Status ⁽¹⁾ (\overline{WP}_F , DQ1, DQ0)		Next Protection Status ⁽¹⁾ (\overline{WP}_F , DQ1, DQ0)			
Current State	Program/Erase Allowed	After Block Lock Command	After Block Unlock Command	After Block Lock-Down Command	After \overline{WP}_F transition
1,0,0	yes	1,0,1	1,0,0	1,1,1	0,0,0
1,0,1 ⁽²⁾	no	1,0,1	1,0,0	1,1,1	0,0,1
1,1,0	yes	1,1,1	1,1,0	1,1,1	0,1,1
1,1,1	no	1,1,1	1,1,0	1,1,1	0,1,1
0,0,0	yes	0,0,1	0,0,0	0,1,1	1,0,0
0,0,1 ⁽²⁾	no	0,0,1	0,0,0	0,1,1	1,0,1
0,1,1	no	0,1,1	0,1,1	0,1,1	1,1,1 or 1,1,0 ⁽³⁾

- Note: 1. The protection status is defined by the write protect pin and by DQ1 ('1' for a locked-down block) and DQ0 ('1' for a locked block) as read in the Read Electronic Signature command with A1 = V_{IH} and A0 = V_{IL}.
 2. All blocks are locked at power-up, so the default configuration is 001 or 101 according to \overline{WP}_F status.
 3. A \overline{WP}_F transition to V_{IH} on a locked block will restore the previous DQ0 value, giving a 111 or 110.

FLASH STATUS REGISTER

The Status Register provides information on the current or previous Program or Erase operation. The various bits convey information and errors on the operation. To read the Status register the Read Status Register command can be issued, refer to Read Status Register Command section. To output the contents, the Status Register is latched on the falling edge of the Chip Enable or Output Enable signals, and can be read until Chip Enable or Output Enable returns to V_{IH} . Either Chip Enable or Output Enable must be toggled to update the latched data.

Bus Read operations from any address always read the Status Register during Program and Erase operations.

The bits in the Status Register are summarized in Table 17, Status Register Bits. Refer to Table 17 in conjunction with the following text descriptions.

Program/Erase Controller Status (Bit 7). The Program/Erase Controller Status bit indicates whether the Program/Erase Controller is active or inactive. When the Program/Erase Controller Status bit is Low (set to '0'), the Program/Erase Controller is active; when the bit is High (set to '1'), the Program/Erase Controller is inactive, and the device is ready to process a new command.

The Program/Erase Controller Status is Low immediately after a Program/Erase Suspend command is issued until the Program/Erase Controller pauses. After the Program/Erase Controller pauses the bit is High.

During Program, Erase, operations the Program/Erase Controller Status bit can be polled to find the end of the operation. Other bits in the Status Register should not be tested until the Program/Erase Controller completes the operation and the bit is High.

After the Program/Erase Controller completes its operation the Erase Status, Program Status, V_{PP} Status and Block Lock Status bits should be tested for errors.

Erase Suspend Status (Bit 6). The Erase Suspend Status bit indicates that an Erase operation has been suspended or is going to be suspended. When the Erase Suspend Status bit is High (set to '1'), a Program/Erase Suspend command has been issued and the memory is waiting for a Program/Erase Resume command.

The Erase Suspend Status should only be considered valid when the Program/Erase Controller Status bit is High (Program/Erase Controller inactive). Bit 7 is set within 30 μ s of the Program/Erase Suspend command being issued therefore the memory may still complete the operation rather than entering the Suspend mode.

When a Program/Erase Resume command is issued the Erase Suspend Status bit returns Low.

Erase Status (Bit 5). The Erase Status bit can be used to identify if the memory has failed to verify that the block has erased correctly. When the Erase Status bit is High (set to '1'), the Program/Erase Controller has applied the maximum number of pulses to the block and still failed to verify that the block has erased correctly. The Erase Status bit should be read once the Program/Erase Controller Status bit is High (Program/Erase Controller inactive).

Once set High, the Erase Status bit can only be reset Low by a Clear Status Register command or a hardware reset. If set High it should be reset before a new Program or Erase command is issued, otherwise the new command will appear to fail.

Program Status (Bit 4). The Program Status bit is used to identify a Program failure. When the Program Status bit is High (set to '1'), the Program/Erase Controller has applied the maximum number of pulses to the byte and still failed to verify that it has programmed correctly. The Program Status bit should be read once the Program/Erase Controller Status bit is High (Program/Erase Controller inactive).

Once set High, the Program Status bit can only be reset Low by a Clear Status Register command or a hardware reset. If set High it should be reset before a new command is issued, otherwise the new command will appear to fail.

V_{PP} Status (Bit 3). The V_{PP} Status bit can be used to identify an invalid voltage on the V_{PP} pin during Program and Erase operations. The V_{PP} pin is only sampled at the beginning of a Program or Erase operation. Indeterminate results can occur if V_{PP} becomes invalid during an operation.

When the V_{PP} Status bit is Low (set to '0'), the voltage on the V_{PP} pin was sampled at a valid voltage; when the V_{PP} Status bit is High (set to '1'), the V_{PP} pin has a voltage that is below the V_{PP} Lockout Voltage, V_{PPLK} , the memory is protected and Program and Erase operations cannot be performed.

Once set High, the V_{PP} Status bit can only be reset Low by a Clear Status Register command or a hardware reset. If set High it should be reset before a new Program or Erase command is issued, otherwise the new command will appear to fail.

Program Suspend Status (Bit 2). The Program Suspend Status bit indicates that a Program operation has been suspended. When the Program Suspend Status bit is High (set to '1'), a Program/Erase Suspend command has been issued and the memory is waiting for a Program/Erase Resume command. The Program Suspend Status should only be considered valid when the Pro-

gram/Erase Controller Status bit is High (Program/Erase Controller inactive). Bit 2 is set within 5µs of the Program/Erase Suspend command being issued therefore the memory may still complete the operation rather than entering the Suspend mode. When a Program/Erase Resume command is issued the Program Suspend Status bit returns Low. **Block Protection Status (Bit 1).** The Block Protection Status bit can be used to identify if a Program or Erase operation has tried to modify the contents of a locked block.

When the Block Protection Status bit is High (set to '1'), a Program or Erase operation has been attempted on a locked block.

Once set High, the Block Protection Status bit can only be reset Low by a Clear Status Register command or a hardware reset. If set High it should be reset before a new command is issued, otherwise the new command will appear to fail.

Reserved (Bit 0). Bit 0 of the Status Register is reserved. Its value must be masked.

Note: Refer to Appendix C, Flowcharts and Pseudo Codes, for using the Status Register.

Table 17. Status Register Bits

Bit	Name	Logic Level	Definition
7	P/E.C. Status	'1'	Ready
		'0'	Busy
6	Erase Suspend Status	'1'	Suspended
		'0'	In progress or Completed
5	Erase Status	'1'	Erase Error
		'0'	Erase Success
4	Program Status	'1'	Program Error
		'0'	Program Success
3	V _{PP} Status	'1'	V _{PP} Invalid, Abort
		'0'	V _{PP} OK
2	Program Suspend Status	'1'	Suspended
		'0'	In Progress or Completed
1	Block Protection Status	'1'	Program/Erase on protected Block, Abort
		'0'	No operation to protected blocks
0	Reserved		

Note: Logic level '1' is High, '0' is Low.

Figure 12. Flash Read Mode AC Waveforms

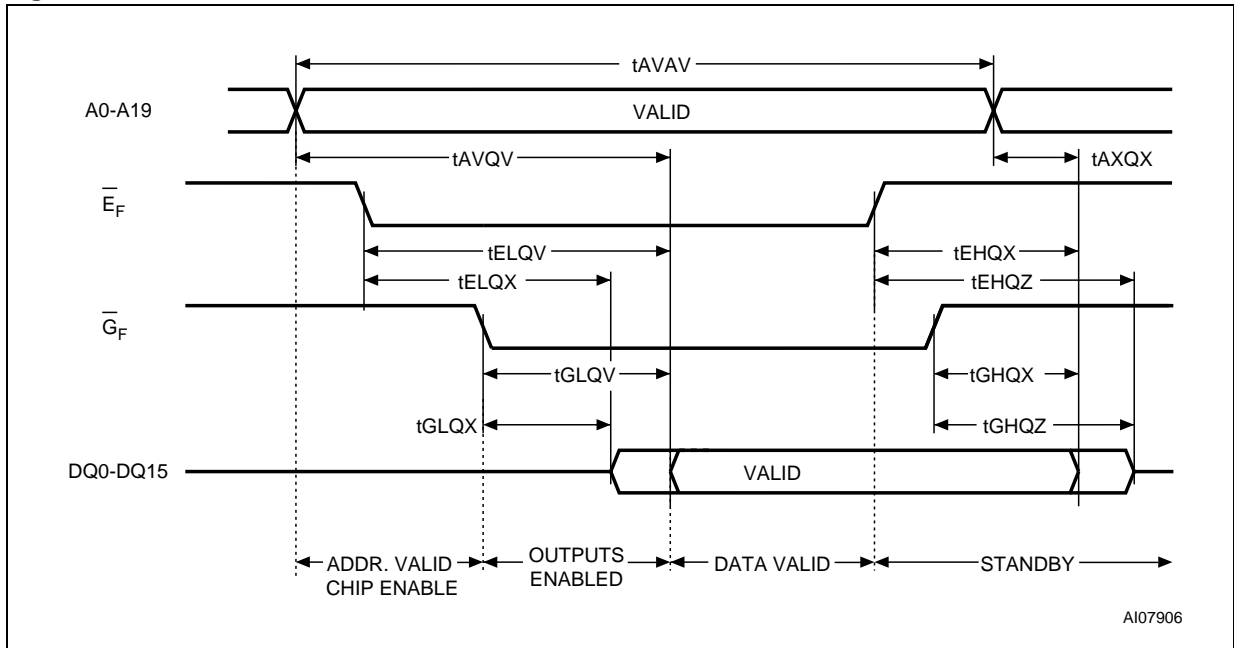

Table 18. Flash Read AC Characteristics

Symbol	Alt	Parameter		Flash		Unit
				70	85	
t_{AVAV}	t_{RC}	Address Valid to Next Address Valid	Min	70	85	ns
t_{AVQV}	t_{ACC}	Address Valid to Output Valid	Max	70	85	ns
$t_{AXQX}^{(1)}$	t_{OH}	Address Transition to Output Transition	Min	0	0	ns
$t_{EHQX}^{(1)}$	t_{OH}	Chip Enable High to Output Transition	Min	0	0	ns
$t_{EHQZ}^{(1)}$	t_{HZ}	Chip Enable High to Output Hi-Z	Max	20	20	ns
$t_{ELQV}^{(2)}$	t_{CE}	Chip Enable Low to Output Valid	Max	70	85	ns
$t_{ELQX}^{(1)}$	t_{LZ}	Chip Enable Low to Output Transition	Min	0	0	ns
$t_{GHQX}^{(1)}$	t_{OH}	Output Enable High to Output Transition	Min	0	0	ns
$t_{GHQZ}^{(1)}$	t_{DF}	Output Enable High to Output Hi-Z	Max	20	20	ns
$t_{GLQV}^{(2)}$	t_{OE}	Output Enable Low to Output Valid	Max	20	20	ns
$t_{GLQX}^{(1)}$	t_{OLZ}	Output Enable Low to Output Transition	Min	0	0	ns

Note: 1. Sampled only, not 100% tested.

2. \bar{G}_F may be delayed by up to $t_{ELQV} - t_{GLQV}$ after the falling edge of \bar{E}_F without increasing t_{ELQV} .

Figure 13. Flash Write AC Waveforms, Write Enable Controlled

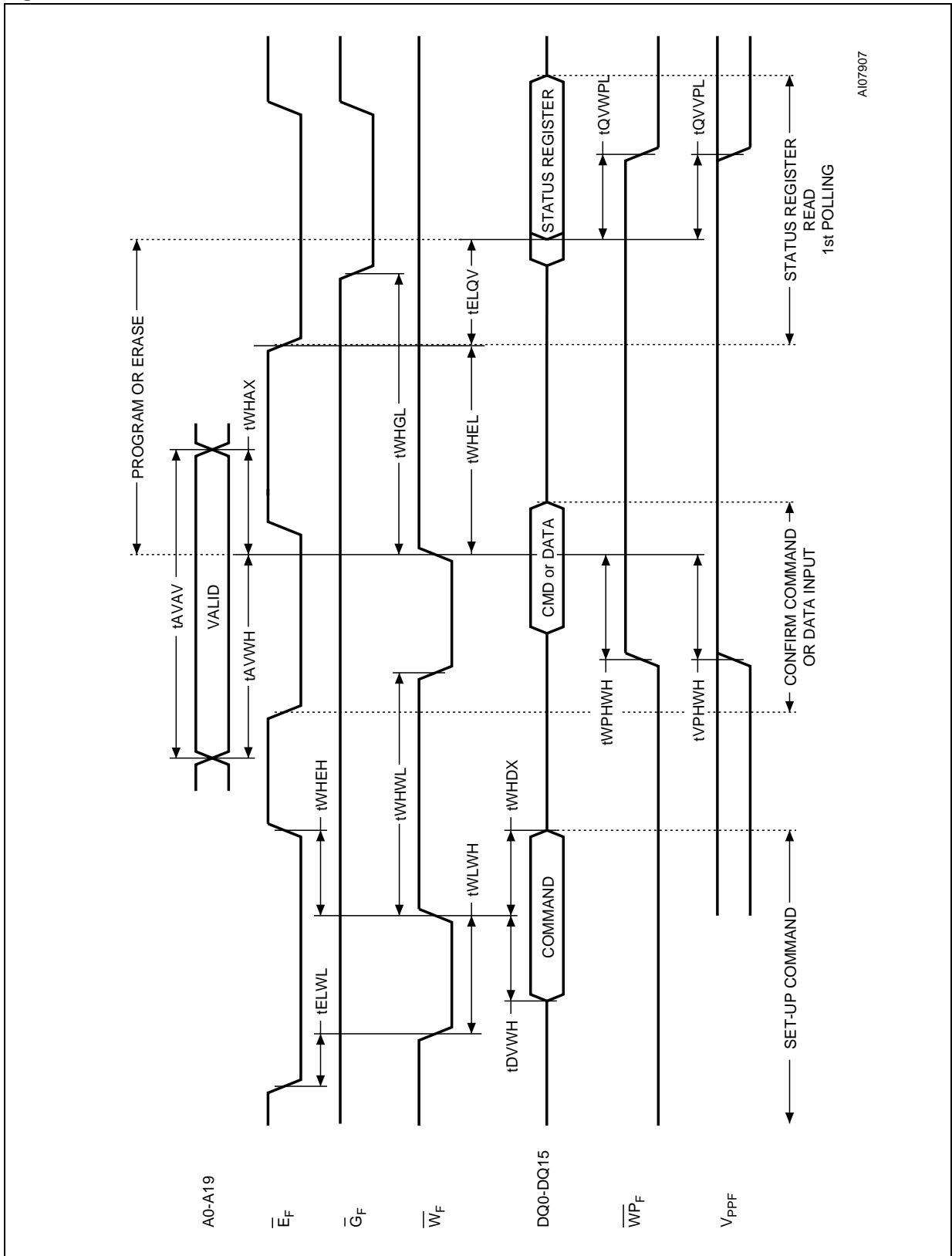

Table 19. Flash Write AC Characteristics, Write Enable Controlled

Symbol	Alt	Parameter		Flash		Unit
				70	85	
t _{AVAV}	t _{WC}	Write Cycle Time	Min	70	85	ns
t _{AVWH}	t _{AS}	Address Valid to Write Enable High	Min	45	45	ns
t _{DVWH}	t _{DS}	Data Valid to Write Enable High	Min	45	45	ns
t _{ELWL}	t _{CS}	Chip Enable Low to Write Enable Low	Min	0	0	ns
t _{ELQV}		Chip Enable Low to Output Valid	Min	70	85	ns
t _{QVVPL} ^(1,2)		Output Valid to V _{PPF} Low	Min	0	0	ns
t _{QVWPL}		Output Valid to Write Protect Low	Min	0	0	ns
t _{VPHWH} ⁽¹⁾	t _{VPS}	V _{PPF} High to Write Enable High	Min	200	200	ns
t _{WHAX}	t _{AH}	Write Enable High to Address Transition	Min	0	0	ns
t _{WHDX}	t _{DH}	Write Enable High to Data Transition	Min	0	0	ns
t _{WHEH}	t _{CH}	Write Enable High to Chip Enable High	Min	0	0	ns
t _{WHEL}		Write Enable High to Output Enable Low	Min	25	25	ns
t _{WHGL}		Write Enable High to Output Enable Low	Min	20	20	ns
t _{WHWL}	t _{WPH}	Write Enable High to Write Enable Low	Min	25	25	ns
t _{WLWH}	t _{WP}	Write Enable Low to Write Enable High	Min	45	45	ns
t _{WPHWH}		Write Protect High to Write Enable High	Min	45	45	ns

Note: 1. Sampled only, not 100% tested.

2. Applicable if V_{PPF} is seen as a logic input (V_{PPF} < 3.6V).

Table 20. Flash Write AC Characteristics, Chip Enable Controlled

Symbol	Alt	Parameter		Flash		Unit
				70	85	
t_{AVAV}	t_{WC}	Write Cycle Time	Min	70	85	ns
t_{AVEH}	t_{AS}	Address Valid to Chip Enable High	Min	45	45	ns
t_{DVEH}	t_{DS}	Data Valid to Chip Enable High	Min	45	45	ns
t_{EHAX}	t_{AH}	Chip Enable High to Address Transition	Min	0	0	ns
t_{EHDX}	t_{DH}	Chip Enable High to Data Transition	Min	0	0	ns
t_{EHEL}	t_{CPH}	Chip Enable High to Chip Enable Low	Min	25	25	ns
t_{EHGL}		Chip Enable High to Output Enable Low	Min	25	25	ns
t_{EHWL}	t_{WH}	Chip Enable High to Write Enable High	Min	0	0	ns
t_{ELEH}	t_{CP}	Chip Enable Low to Chip Enable High	Min	45	45	ns
t_{ELQV}		Chip Enable Low to Output Valid	Min	70	85	ns
$t_{QVVPL}^{(1,2)}$		Output Valid to V_{PPF} Low	Min	0	0	ns
t_{QVWPL}		Data Valid to Write Protect Low	Min	0	0	ns
$t_{VPHEH}^{(1)}$	t_{VPS}	V_{PPF} High to Chip Enable High	Min	200	200	ns
t_{WLEL}	t_{CS}	Write Enable Low to Chip Enable Low	Min	0	0	ns
t_{WPHEH}		Write Protect High to Chip Enable High	Min	45	45	ns

Note: 1. Sampled only, not 100% tested.

2. Applicable if V_{PPF} is seen as a logic input ($V_{PPF} < 3.6V$).

Figure 15. Flash Power-Up and Reset AC Waveforms

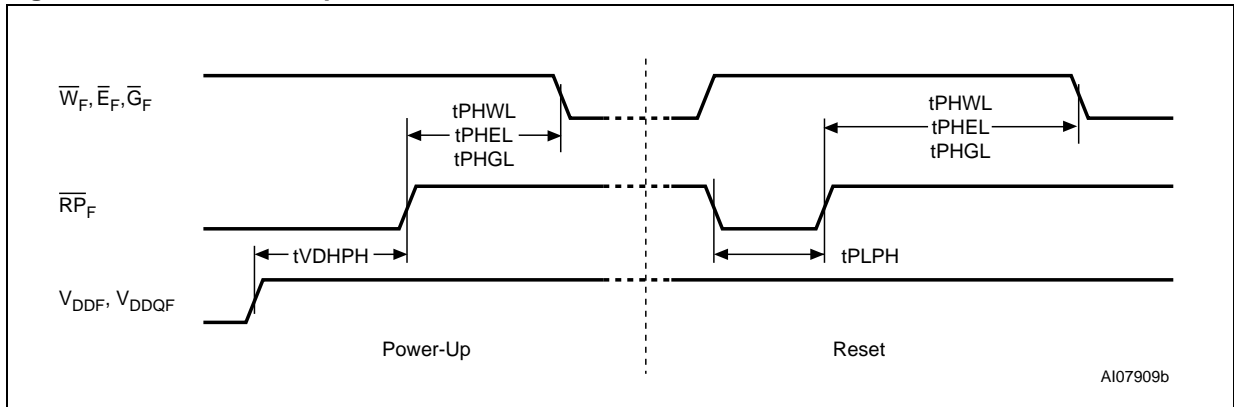

Table 21. Flash Power-Up and Reset AC Characteristics

Symbol	Parameter	Test Condition		Flash		Unit
				70	85	
t _{PHWL} t _{PEHL} t _{PHGL}	Reset High to Write Enable Low, Chip Enable Low, Output Enable Low	During Program and Erase	Min	50	50	μs
		others	Min	30	30	ns
t _{PLPH} ^(1,2)	Reset Low to Reset High		Min	100	100	ns
t _{VDHPH} ⁽³⁾	Supply Voltages High to Reset High		Min	50	50	μs

Note: 1. The device Reset is possible but not guaranteed if t_{PLPH} < 100ns.

2. Sampled only, not 100% tested.

3. It is important to assert \overline{RP}_F in order to allow proper CPU initialization during power up or reset.

SRAM DEVICE

This section describes how to use the SRAM and all signals refer to it.

SRAM SUMMARY DESCRIPTION

The SRAM is a 2 Mbit asynchronous random access memory which features super low voltage operation and low current consumption with an access time of 70 ns under all conditions. The

memory operations can be performed using a single low voltage supply, 2.7V to 3.3V, which is the same as the Flash component's voltage supply.

Figure 16. SRAM Logic Diagram

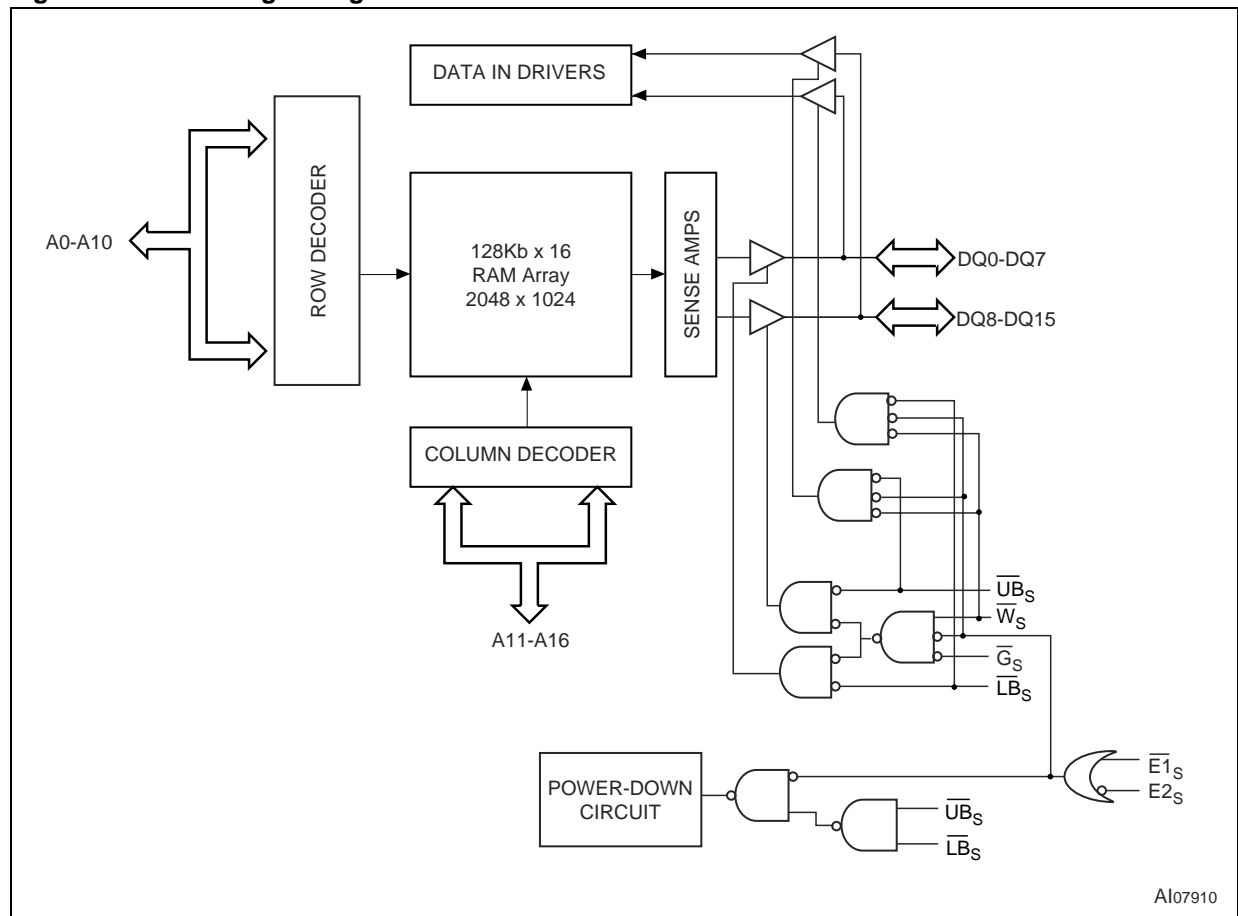

SRAM OPERATIONS

There are five standard operations that control the SRAM component. These are Bus Read, Bus Write, Standby/Power-down, Data Retention and Output Disable. A summary is shown in Table 2, Main Operation Modes

Read. Read operations are used to output the contents of the SRAM Array. The SRAM is in Read mode whenever Write Enable, \overline{W}_S , is at V_{IH} , Output Enable, \overline{G}_S , is at V_{IL} , Chip Enable, $\overline{E1}_S$, is at V_{IL} , Chip Enable, $E2_S$, is at V_{IH} , and one or both of the Byte Enables, \overline{UB}_S and \overline{LB}_S is/are at V_{IL} .

Valid data will be available on the output pins after a time of t_{AVQV} after the last stable address. If the Chip Enable or Output Enable access times are not met, data access will be measured from the limiting parameter (t_{E1LQV} , t_{E2HQV} , or t_{GLQV}) rather than the address. Data out may be indeterminate at t_{E1LQX} , t_{E2HQX} and t_{GLQX} , but data lines will always be valid at t_{AVQV} (see Table 22, Figures 17 and 18).

Write. Write operations are used to write data to the SRAM. The SRAM is in Write mode whenever \overline{W}_S and $\overline{E1}_S$ are at V_{IL} , and $E2_S$ is at V_{IH} . Either the Chip Enable inputs, $\overline{E1}_S$ and $E2_S$, or the Write Enable input, \overline{W}_S , must be deasserted during address transitions for subsequent write cycles.

A Write operation is initiated when $\overline{E1}_S$ is at V_{IL} , $E2_S$ is at V_{IH} and \overline{W}_S is at V_{IL} . The data is latched on the falling edge of $\overline{E1}_S$, the rising edge of $E2_S$ or the falling edge of \overline{W}_S , whichever occurs last. The Write cycle is terminated on the rising edge of $\overline{E1}_S$,

the rising edge of \overline{W}_S or the falling edge of $E2_S$, whichever occurs first.

If the Output is enabled ($\overline{E1}_S=V_{IL}$, $E2_S=V_{IH}$ and $\overline{G}_S=V_{IL}$), then \overline{W}_S will return the outputs to high impedance within t_{WLQZ} of its falling edge. Care must be taken to avoid bus contention in this type of operation. The Data input must be valid for t_{DVVWH} before the rising edge of Write Enable, for t_{DVE1H} before the rising edge of $\overline{E1}_S$ or for t_{DVE2L} before the falling edge of $E2_S$, whichever occurs first, and remain valid for t_{WHDX} , t_{E1HAX} or t_{E2LAX} (see Table 23, Figures 20, 21, 22 and 23).

Standby/Power-Down. The SRAM component has a chip enabled power-down feature which invokes an automatic standby mode (see Table 22, Figure 19). The SRAM is in Standby mode whenever either Chip Enable is deasserted, $\overline{E1}_S$ at V_{IH} or $E2_S$ at V_{IL} . It is also possible when \overline{UB}_S and \overline{LB}_S are at V_{IH} .

Data Retention. The SRAM data retention performances as V_{DDs} go down to V_{DR} are described in Table 24 and Figure 24. In $\overline{E1}_S$ controlled data retention mode, the minimum standby current mode is entered when $\overline{E1}_S \geq V_{DDs} - 0.2V$ and $E2_S \leq 0.2V$ or $E2_S \geq V_{DDs} - 0.2V$. In $E2_S$ controlled data retention mode, minimum standby current mode is entered when $E2_S \leq 0.2V$.

Output Disable. The data outputs are high impedance when the Output Enable, \overline{G}_S , is at V_{IH} with Write Enable, \overline{W}_S , at V_{IH} .

Figure 17. SRAM Read Mode AC Waveforms, Address Controlled with $\overline{UB}_S = \overline{LB}_S = V_{IL}$

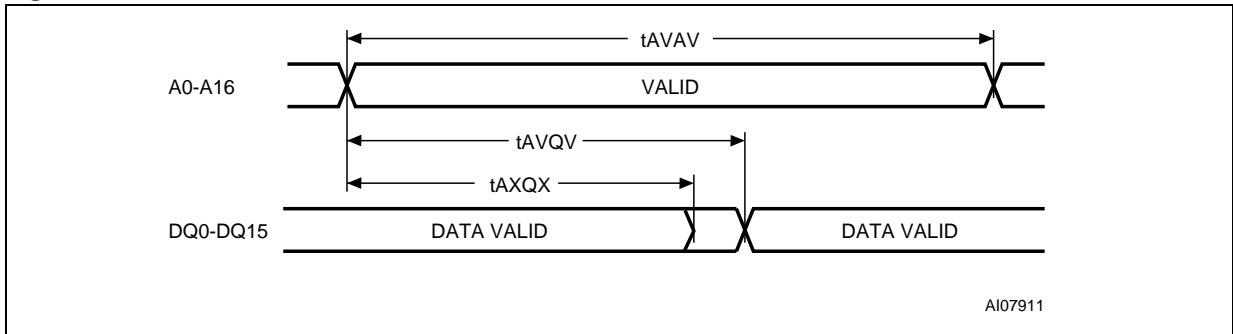

Note: $\overline{E1}_S = \text{Low}$, $E2_S = \text{High}$, $\overline{G}_S = \text{Low}$, $\overline{W}_S = \text{High}$.

Figure 18. SRAM Read AC Waveforms, \overline{G}_S Controlled

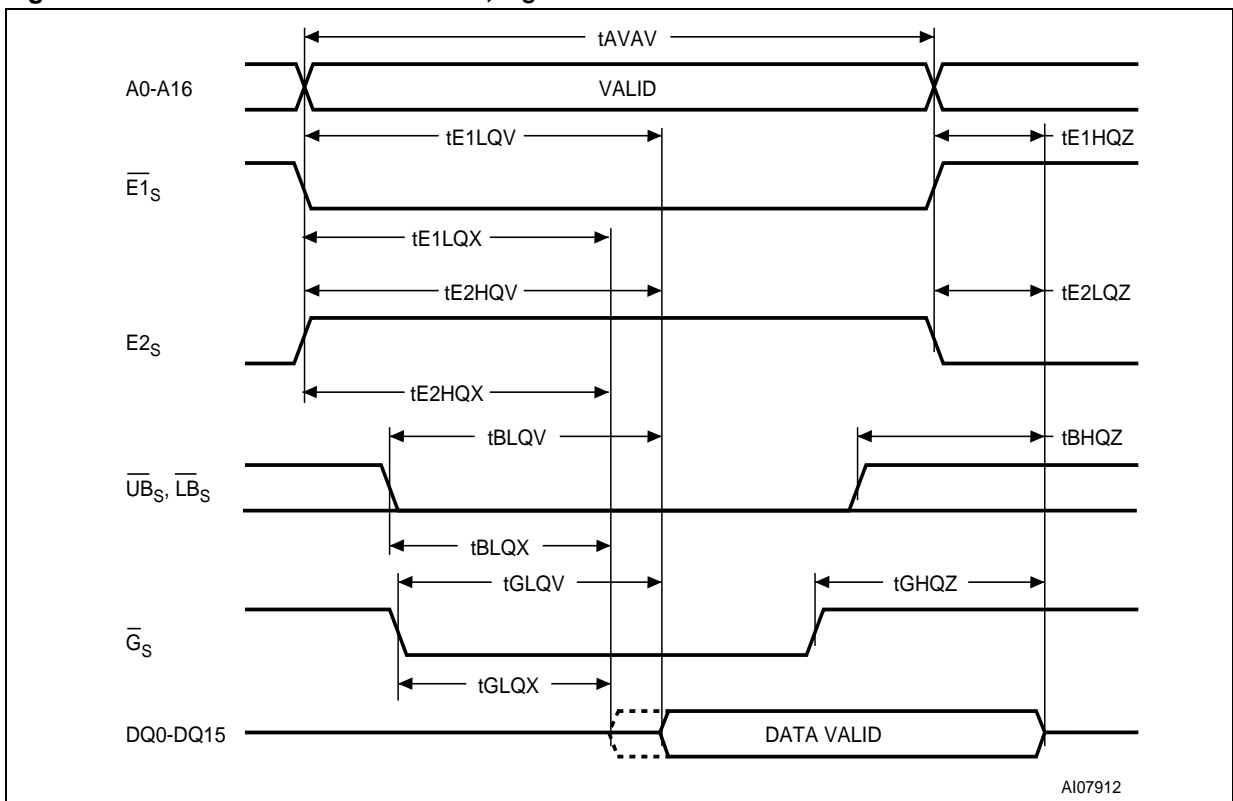

Note: Write Enable (\overline{W}_S) = High. Address Valid prior to or at the same time as $\overline{E1}_S$, \overline{UB}_S and \overline{LB}_S going Low.

Figure 19. SRAM Standby AC Waveforms

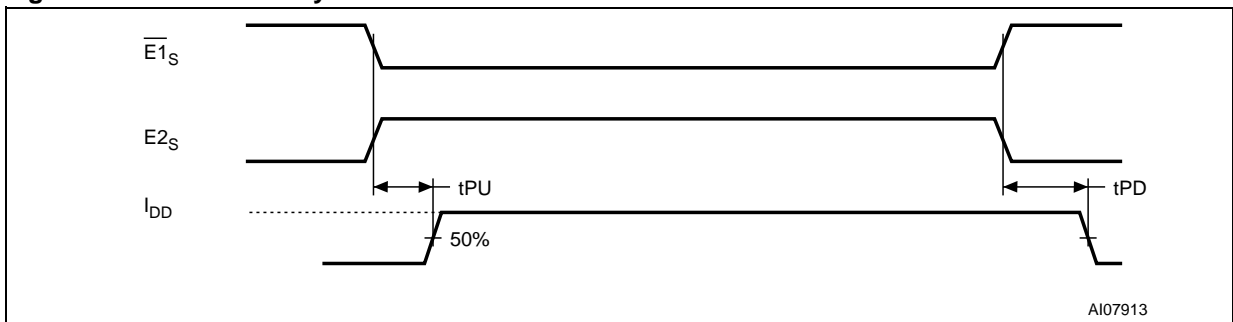
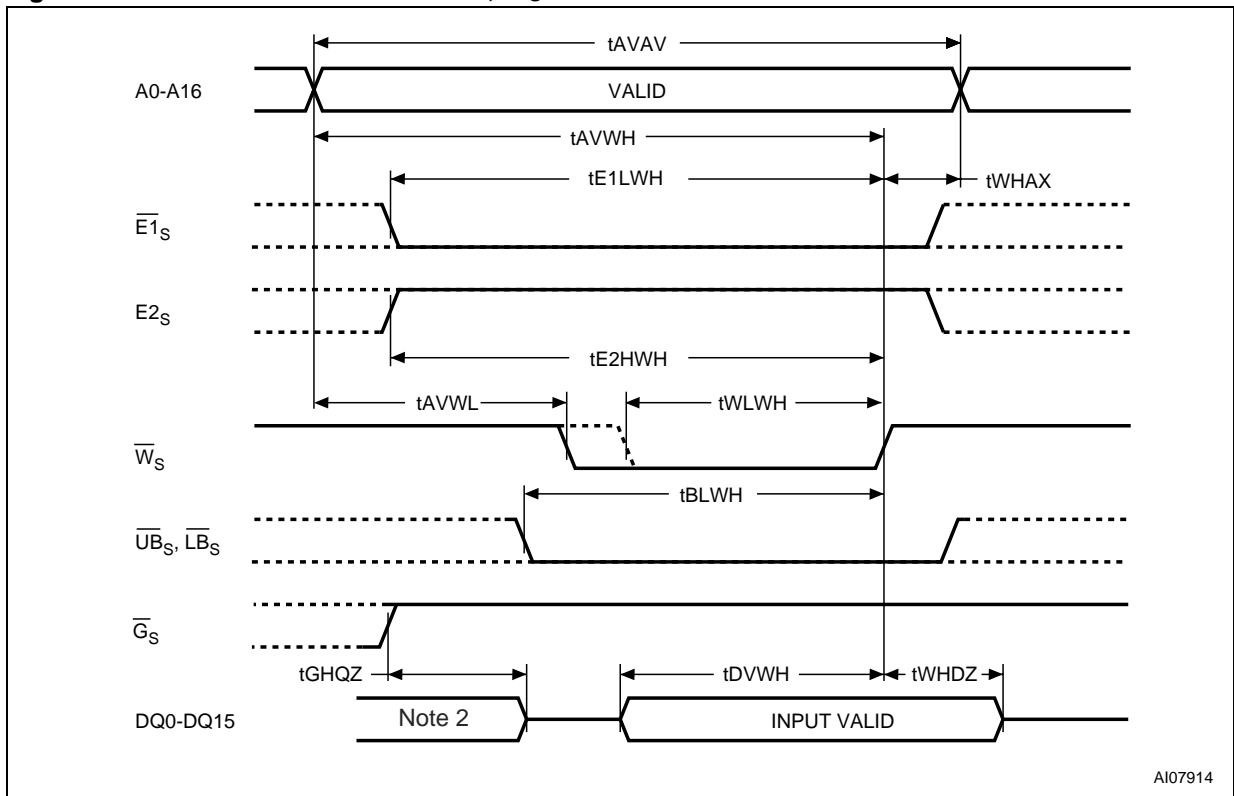

Table 22. SRAM Read AC Characteristics

Symbol	Alt	Parameter	SRAM		Unit
			Min	Max	
t _{AVAV}	t _{RC}	Read Cycle Time	70		ns
t _{AVQV}	t _{ACC}	Address Valid to Output Valid		70	ns
t _{AXQX}	t _{OH}	Address Transition to Output Transition	10		ns
t _{BHQZ}	t _{BHZ}	$\overline{UB}_S, \overline{LB}_S$ Disable to Hi-Z Output		25	ns
t _{BLQV}	t _{AB}	$\overline{UB}_S, \overline{LB}_S$ Access Time		70	ns
t _{BLQX}	t _{BLZ}	$\overline{UB}_S, \overline{LB}_S$ Enable to Low-Z Output	5		ns
t _{E1HQZ}	t _{CHZ1}	Chip Enable 1 High to Output Hi-Z		25	ns
t _{E1LQV}	t _{ACS1}	Chip Enable 1 Low to Output Valid		70	ns
t _{E1LQX}	t _{CLZ1}	Chip Enable 1 Low to Output Transition	10		ns
t _{E2HQV}	t _{ACS2}	Chip Enable 2 High to Output Valid		70	ns
t _{E2HQX}	t _{CLZ2}	Chip Enable 2 High to Output Transition	10		ns
t _{E2LQZ}	t _{CHZ2}	Chip Enable 2 Low to Output Hi-Z		25	ns
t _{GHQZ}	t _{OHZ}	Output Enable High to Output Hi-Z		25	ns
t _{GLQV}	t _{OE}	Output Enable Low to Output Valid		35	ns
t _{GLQX}	t _{OLZ}	Output Enable Low to Output Transition	5		ns
t _{PD} ⁽¹⁾		Chip Enable 1 High or Chip Enable 2 Low to Power Down		70	ns
t _{PU} ⁽¹⁾		Chip Enable 1 Low or Chip Enable 2 High to Power Up	0		ns

Note: 1. Sampled only. Not 100% tested.

Figure 20. SRAM Write AC Waveforms, \overline{W}_S Controlled

Note: \overline{W}_S , $\overline{E1}_S$, $E2_S$, \overline{UB}_S and/or \overline{LB}_S must be asserted to initiate a write cycle. Output Enable (\overline{G}_S) = Low (otherwise, DQ0-DQ15 are high impedance). If $\overline{E1}_S$, $E2_S$ and \overline{W}_S are deasserted at the same time, DQ0-DQ15 remain high impedance.

2. The I/O pins are in output mode and input signals must not be applied.

Figure 21. SRAM Write AC Waveforms, $\overline{E1}_S$ Controlled

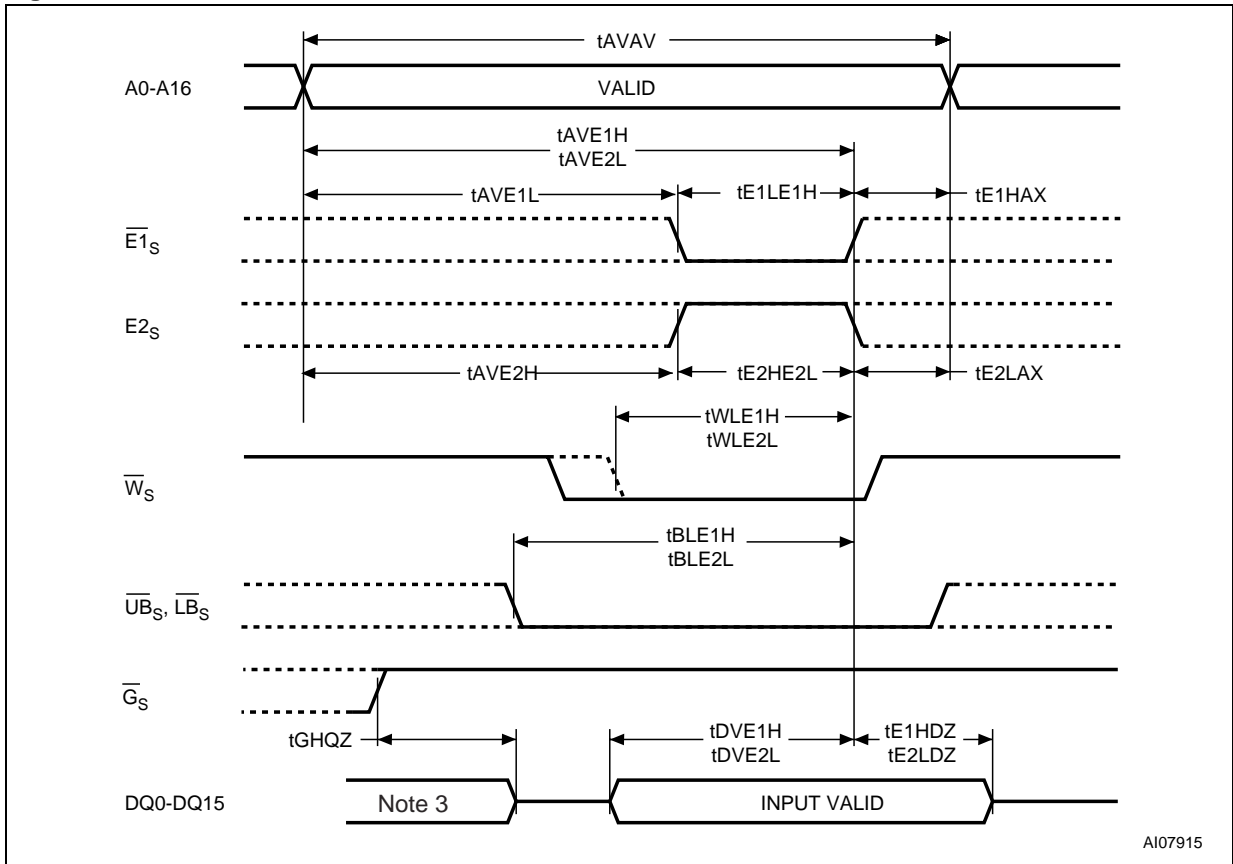

- Note: 1. \overline{W}_S , $\overline{E1}_S$, $E2_S$, \overline{UB}_S and/or \overline{LB}_S must be asserted to initiate a write cycle. Output Enable (\overline{G}_S) = Low (otherwise, DQ0-DQ15 are high impedance). If $\overline{E1}_S$, $E2_S$ and \overline{W}_S are deasserted at the same time, DQ0-DQ15 remain high impedance.
2. If $\overline{E1}_S$, $E2_S$ and \overline{W}_S are deasserted at the same time, DQ0-DQ15 remain high impedance.
3. The I/O pins are in output mode and input signals must not be applied.

Figure 22. SRAM Write AC Waveforms, \overline{W}_S Controlled with \overline{G}_S Low

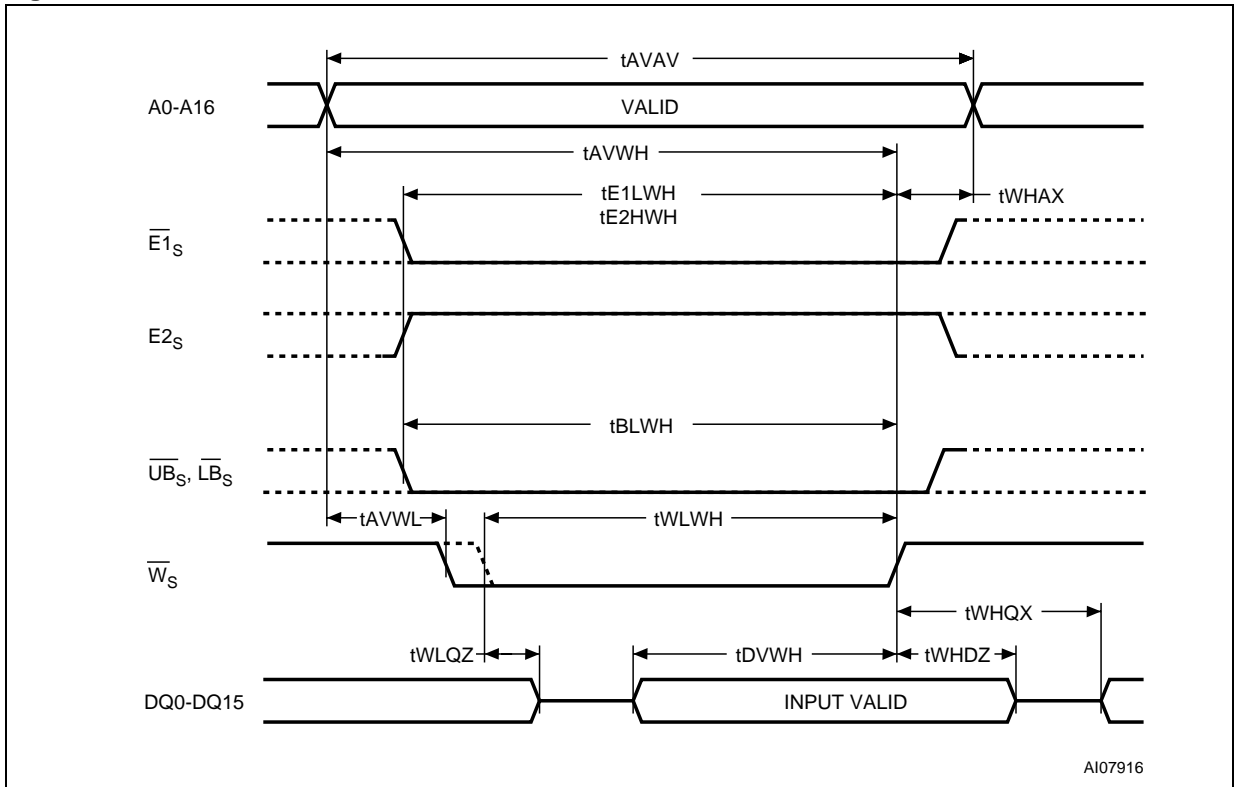

Note: 1. If $\overline{E1}_S$, $E2_S$ and \overline{W}_S are deasserted at the same time, DQ0-DQ15 remain high impedance.

Figure 23. SRAM Write Cycle Waveform, \overline{UB}_S and \overline{LB}_S Controlled, \overline{G}_S Low

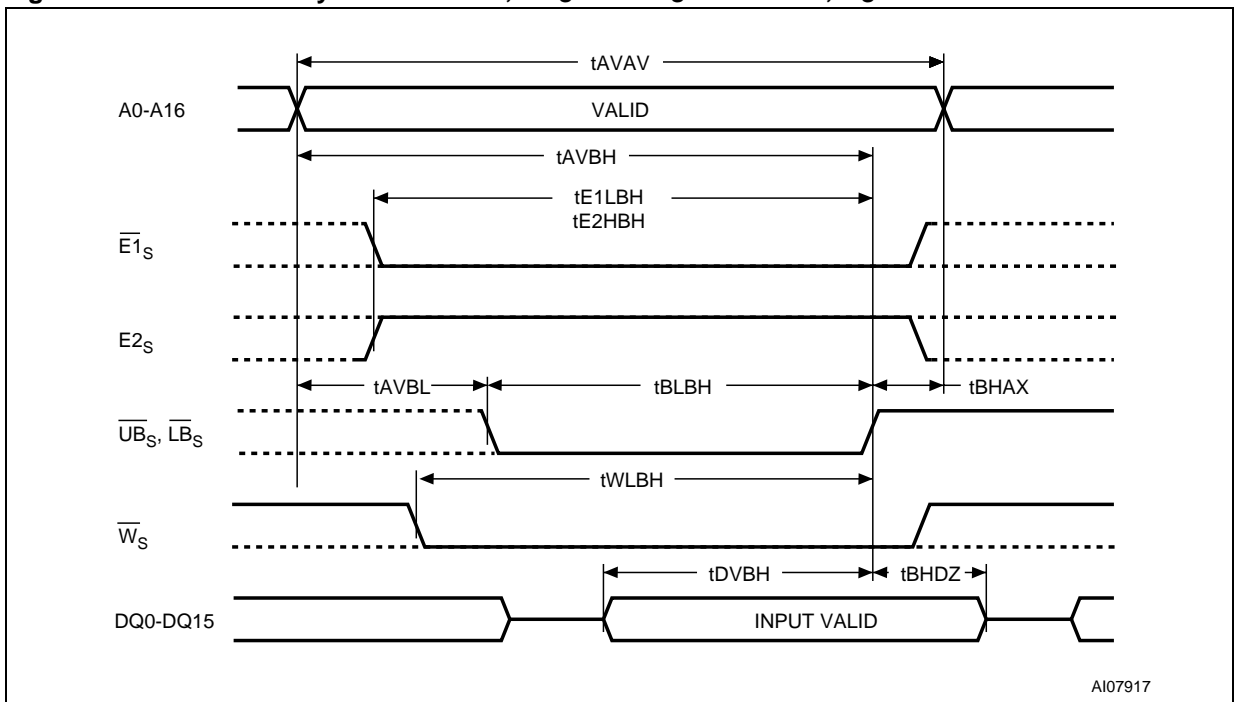

Note: 1. If $\overline{E1}_S$, $E2_S$ and \overline{W}_S are deasserted at the same time, DQ0-DQ15 remain high impedance.

Table 23. SRAM Write AC Characteristics

Symbol	Alt	Parameter	SRAM		Unit
			Min	Max	
t_{AVAV}	t_{WC}	Write Cycle Time	70		ns
t_{AVE1L} , t_{AVE2H} , t_{AVWL}	t_{AS}	Address Valid to Beginning of Write	0		ns
t_{AVWH}	t_{AW}	Address Valid to Write Enable High	60		ns
t_{BLWH} t_{BLE1H} t_{BLE2L} t_{AVBH}	t_{BW}	$\overline{UB}_S, \overline{LB}_S$ Valid to End of Write	60		ns
t_{DVE1H} , t_{DVE2L} , t_{DVWH} t_{DVBH}	t_{DW}	Input Valid to End of Write	30		ns
t_{E1HAX} , t_{E2LAX} , t_{WHAX}	t_{WR}	End of Write to Address Change	0		ns
t_{E1HDZ} , t_{E2LDZ} , t_{WHDZ} t_{BHDZ}	t_{HD}	Address Transition to End of Write	0		ns
t_{E1LEIH} , t_{E1LWH}	t_{CW1}	Chip Enable 1 Low to End of Write	60		ns
t_{E2HE2L} t_{E2HWH}	t_{CW2}	Chip Enable 2 High to End of Write	60		ns
t_{WHQX}	t_{DH}	Write Enable High to Input Transition	10		ns
t_{WLQZ}	t_{WHZ}	Write Enable Low to Output Hi-Z		25	ns
t_{WLWH} t_{WLE1H} t_{WLE2L}	t_{WP}	Write Enable Pulse Width	45		ns

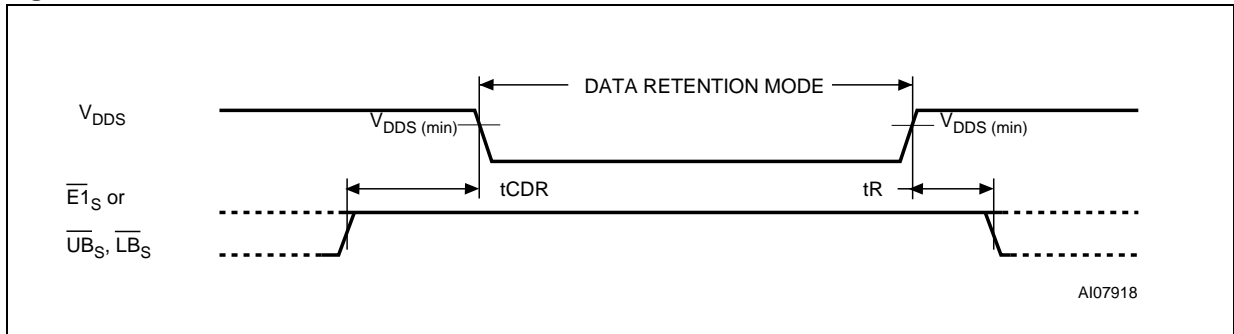
Figure 24. SRAM Low $V_{DD\bar{S}}$ Data Retention AC Waveforms, $\bar{E}1\bar{S}$ or $\bar{U}\bar{B}\bar{S}$ / $\bar{L}\bar{B}\bar{S}$ ControlledTable 24. SRAM Low $V_{DD\bar{S}}$ Data Retention Characteristic

Symbol	Parameter	Test Condition	Min	Typ	Max	Unit
I_{DDDR}	Supply Current (Data Retention)	$V_{DD\bar{S}} = 1.5V$, $\bar{E}1\bar{S} \geq V_{DD\bar{S}} - 0.2V$, $V_{IN} \geq V_{DD\bar{S}} - 0.2V$ or $V_{IN} \leq 0.2V$		3	10	μA
V_{DR}	Supply Voltage (Data Retention)		1.5		3.3	V
t_{CDR}	Chip Disable to Power Down	$\bar{E}1\bar{S} \geq V_{CC\bar{S}} - 0.2V$, $E2\bar{S} \leq 0.2V$	0			ns
t_R	Operation Recovery Time		70			ns

Note: 1. All other Inputs $V_{IH} \leq V_{DD\bar{S}} - 0.2V$ or $V_{IL} \leq 0.2V$.
2. Sampled only. Not 100% tested.

APPENDIX A. BLOCK ADDRESS TABLES

Table 25. Top Boot Block Addresses, M36W216TI

#	Size (KWord)	Address Range
0	4	FF000-FFFFF
1	4	FE000-FEFFF
2	4	FD000-FDFFF
3	4	FC000-FCFFF
4	4	FB000-FBFFF
5	4	FA000-FAFFF
6	4	F9000-F9FFF
7	4	F8000-F8FFF
8	32	F0000-F7FFF
99	32	E8000-EFFFF
10	32	E0000-E7FFF
11	32	D8000-DFFFF
12	32	D0000-D7FFF
13	32	C8000-CFFFF
14	32	C0000-C7FFF
15	32	B8000-BFFFF
16	32	B0000-B7FFF
17	32	A8000-AFFFF
18	32	A0000-A7FFF
19	32	98000-9FFFF
20	32	90000-97FFF
21	32	88000-8FFFF
22	32	80000-87FFF
23	32	78000-7FFFF
24	32	70000-77FFF
25	32	68000-6FFFF
26	32	60000-67FFF
27	32	58000-5FFFF
28	32	50000-57FFF
29	32	48000-4FFFF
30	32	40000-47FFF
31	32	38000-3FFFF
32	32	30000-37FFF
33	32	28000-2FFFF
34	32	20000-27FFF
35	32	18000-1FFFF
36	32	10000-17FFF
37	32	08000-0FFFF
38	32	00000-07FFF

Table 26. Bottom Boot Block Addresses, M36W216BI

#	Size (KWord)	Address Range
38	32	F8000-FFFFF
37	32	F0000-F7FFF
36	32	E8000-EFFFF
35	32	E0000-E7FFF
34	32	D8000-DFFFF
33	32	D0000-D7FFF
32	32	C8000-CFFFF
31	32	C0000-C7FFF
30	32	B8000-BFFFF
29	32	B0000-B7FFF
28	32	A8000-AFFFF
27	32	A0000-A7FFF
26	32	98000-9FFFF
25	32	90000-97FFF
24	32	88000-8FFFF
23	32	80000-87FFF
22	32	78000-7FFFF
21	32	70000-77FFF
20	32	68000-6FFFF
19	32	60000-67FFF
18	32	58000-5FFFF
17	32	50000-57FFF
16	32	48000-4FFFF
15	32	40000-47FFF
14	32	38000-3FFFF
13	32	30000-37FFF
12	32	28000-2FFFF
11	32	20000-27FFF
10	32	18000-1FFFF
9	32	10000-17FFF
8	32	08000-0FFFF
7	4	07000-07FFF
6	4	06000-06FFF
5	4	05000-05FFF
4	4	04000-04FFF
3	4	03000-03FFF
2	4	02000-02FFF
1	4	01000-01FFF
0	4	00000-00FFF

APPENDIX B. COMMON FLASH INTERFACE (CFI)

The Common Flash Interface is a JEDEC approved, standardized data structure that can be read from the Flash memory device. It allows a system software to query the device to determine various electrical and timing parameters, density information and functions supported by the memory. The system can interface easily with the device, enabling the software to upgrade itself when necessary.

When the CFI Query Command (RCFI) is issued the device enters CFI Query mode and the data

structure is read from the memory. Tables 27, 28, 29, 30, 31 and 32 show the addresses used to retrieve the data.

The CFI data structure also contains a security area where a 64 bit unique security number is written (see Table 32, Security Code area). This area can be accessed only in Read mode by the final user. It is impossible to change the security number after it has been written by ST. Issue a Read command to return to Read mode.

Table 27. Query Structure Overview

Offset	Sub-section Name	Description
00h	Reserved	Reserved for algorithm-specific information
10h	CFI Query Identification String	Command set ID and algorithm data offset
1Bh	System Interface Information	Device timing & voltage information
27h	Device Geometry Definition	Flash device layout
P	Primary Algorithm-specific Extended Query table	Additional information specific to the Primary Algorithm (optional)
A	Alternate Algorithm-specific Extended Query table	Additional information specific to the Alternate Algorithm (optional)

Note: Query data are always presented on the lowest order data outputs.

Table 28. CFI Query Identification String

Offset	Data	Description	Value
00h	0020h	Manufacturer Code	ST
01h	88CEh 88CFh	Device Code	Top Bottom
02h-0Fh	reserved	Reserved	
10h	0051h	Query Unique ASCII String "QRY"	"Q"
11h	0052h		"R"
12h	0059h		"Y"
13h	0003h	Primary Algorithm Command Set and Control Interface ID code 16 bit ID code defining a specific algorithm	Intel compatible
14h	0000h		
15h	0035h	Address for Primary Algorithm extended Query table (see Table 30)	P = 35h
16h	0000h		
17h	0000h	Alternate Vendor Command Set and Control Interface ID Code second vendor - specified algorithm supported (0000h means none exists)	NA
18h	0000h		
19h	0000h	Address for Alternate Algorithm extended Query table (0000h means none exists)	NA
1Ah	0000h		

Note: Query data are always presented on the lowest order data outputs (DQ7-DQ0) only. DQ8-DQ15 are '0'.

Table 29. CFI Query System Interface Information

Offset	Data	Description	Value
1Bh	0027h	V _{DD} Logic Supply Minimum Program/Erase or Write voltage bit 7 to 4 BCD value in volts bit 3 to 0 BCD value in 100 mV	2.7V
1Ch	0036h	V _{DD} Logic Supply Maximum Program/Erase or Write voltage bit 7 to 4 BCD value in volts bit 3 to 0 BCD value in 100 mV	3.6V
1Dh	00B4h	V _{PP} [Programming] Supply Minimum Program/Erase voltage bit 7 to 4 HEX value in volts bit 3 to 0 BCD value in 100 mV	11.4V
1Eh	00C6h	V _{PP} [Programming] Supply Maximum Program/Erase voltage bit 7 to 4 HEX value in volts bit 3 to 0 BCD value in 100 mV	12.6V
1Fh	0004h	Typical time-out per single word program = 2 ⁿ μs	16μs
20h	0004h	Typical time-out for Double Word Program = 2 ⁿ μs	16μs
21h	000Ah	Typical time-out per individual block erase = 2 ⁿ ms	1s
22h	0000h	Typical time-out for full chip erase = 2 ⁿ ms	NA
23h	0005h	Maximum time-out for word program = 2 ⁿ times typical	512μs
24h	0005h	Maximum time-out for Double Word Program = 2 ⁿ times typical	512μs
25h	0003h	Maximum time-out per individual block erase = 2 ⁿ times typical	8s
26h	0000h	Maximum time-out for chip erase = 2 ⁿ times typical	NA

Table 30. Device Geometry Definition

Offset Word Mode	Data	Description	Value
27h	0015h	Device Size = 2^n in number of bytes	2 MByte
28h 29h	0001h 0000h	Flash Device Interface Code description	x16 Async.
2Ah 2Bh	0002h 0000h	Maximum number of bytes in multi-byte program or page = 2^n	4
2Ch	0002h	Number of Erase Block Regions within the device. It specifies the number of regions within the device containing contiguous Erase Blocks of the same size.	2
M36W216TI	2Dh 2Eh	Region 1 Information Number of identical-size erase block = 001Eh+1	31
	2Fh 30h	Region 1 Information Block size in Region 1 = 0100h * 256 byte	64 KByte
	31h 32h	Region 2 Information Number of identical-size erase block = 0007h+1	8
	33h 34h	Region 2 Information Block size in Region 2 = 0020h * 256 byte	8 KByte
M36W216BI	2Dh 2Eh	Region 1 Information Number of identical-size erase block = 0007h+1	8
	2Fh 30h	Region 1 Information Block size in Region 1 = 0020h * 256 byte	8 KByte
	31h 32h	Region 2 Information Number of identical-size erase block = 001Eh+1	31
	33h 34h	Region 2 Information Block size in Region 2 = 0100h * 256 byte	64 KByte

Table 31. Primary Algorithm-Specific Extended Query Table

Offset P = 35h (1)	Data	Description	Value
(P+0)h = 35h	0050h	Primary Algorithm extended Query table unique ASCII string "PRI"	"P"
(P+1)h = 36h	0052h		"R"
(P+2)h = 37h	0049h		"I"
(P+3)h = 38h	0031h	Major version number, ASCII	"1"
(P+4)h = 39h	0030h	Minor version number, ASCII	"0"
(P+5)h = 3Ah	0066h	Extended Query table contents for Primary Algorithm. Address (P+5)h contains less significant byte. bit 0 Chip Erase supported (1 = Yes, 0 = No) bit 1 Suspend Erase supported (1 = Yes, 0 = No) bit 2 Suspend Program supported (1 = Yes, 0 = No) bit 3 Legacy Lock/Unlock supported (1 = Yes, 0 = No) bit 4 Queued Erase supported (1 = Yes, 0 = No) bit 5 Instant individual block locking supported (1 = Yes, 0 = No) bit 6 Protection bits supported (1 = Yes, 0 = No) bit 7 Page mode read supported (1 = Yes, 0 = No) bit 8 Synchronous read supported (1 = Yes, 0 = No) bit 31 to 9 Reserved; undefined bits are '0'	No
(P+6)h = 3Bh	0000h		Yes
(P+7)h = 3Ch	0000h		No
(P+8)h = 3Dh	0000h		Yes
			No
			Yes
			Yes
			No
			No
(P+9)h = 3Eh	0001h	Supported Functions after Suspend Read Array, Read Status Register and CFI Query are always supported during Erase or Program operation bit 0 Program supported after Erase Suspend (1 = Yes, 0 = No) bit 7 to 1 Reserved; undefined bits are '0'	Yes
(P+A)h = 3Fh	0003h	Block Lock Status Defines which bits in the Block Status Register section of the Query are implemented. Address (P+A)h contains less significant byte bit 0 Block Lock Status Register Lock/Unlock bit active (1 = Yes, 0 = No) bit 1 Block Lock Status Register Lock-Down bit active (1 = Yes, 0 = No) bit 15 to 2 Reserved for future use; undefined bits are '0'	Yes
(P+B)h = 40h	0000h		Yes
(P+C)h = 41h	0030h	V _{DD} Logic Supply Optimum Program/Erase voltage (highest performance) bit 7 to 4 HEX value in volts bit 3 to 0 BCD value in 100 mV	3V
(P+D)h = 42h	00C0h	V _{PP} Supply Optimum Program/Erase voltage bit 7 to 4 HEX value in volts bit 3 to 0 BCD value in 100 mV	12V
(P+E)h = 43h	0001h	Number of Protection register fields in JEDEC ID space. "00h," indicates that 256 protection bytes are available	01
(P+F)h = 44h	0080h	Protection Field 1: Protection Description This field describes user-available. One Time Programmable (OTP) Protection register bytes. Some are pre-programmed with device unique serial numbers. Others are user programmable. Bits 0–15 point to the Protection register Lock byte, the section's first byte. The following bytes are factory pre-programmed and user-programmable. bit 0 to 7 Lock/bytes JEDEC-plane physical low address bit 8 to 15 Lock/bytes JEDEC-plane physical high address bit 16 to 23 "n" such that 2 ⁿ = factory pre-programmed bytes bit 24 to 31 "n" such that 2 ⁿ = user programmable bytes	80h
(P+10)h = 45h	0000h		00h
(P+11)h = 46h	0003h		8 Byte
(P+12)h = 47h	0003h		8 Byte
(P+13)h = 48h		Reserved	

Note: 1. See Table 28, offset 15 for P pointer definition.

Table 32. Security Code Area

Offset	Data	Description
80h	00XX	Protection Register Lock
81h	XXXX	64 bits: unique device number
82h	XXXX	
83h	XXXX	
84h	XXXX	
85h	XXXX	64 bits: User Programmable OTP
86h	XXXX	
87h	XXXX	
88h	XXXX	

APPENDIX C. FLOWCHARTS AND PSEUDO CODES

Figure 25. Program Flowchart and Pseudo Code

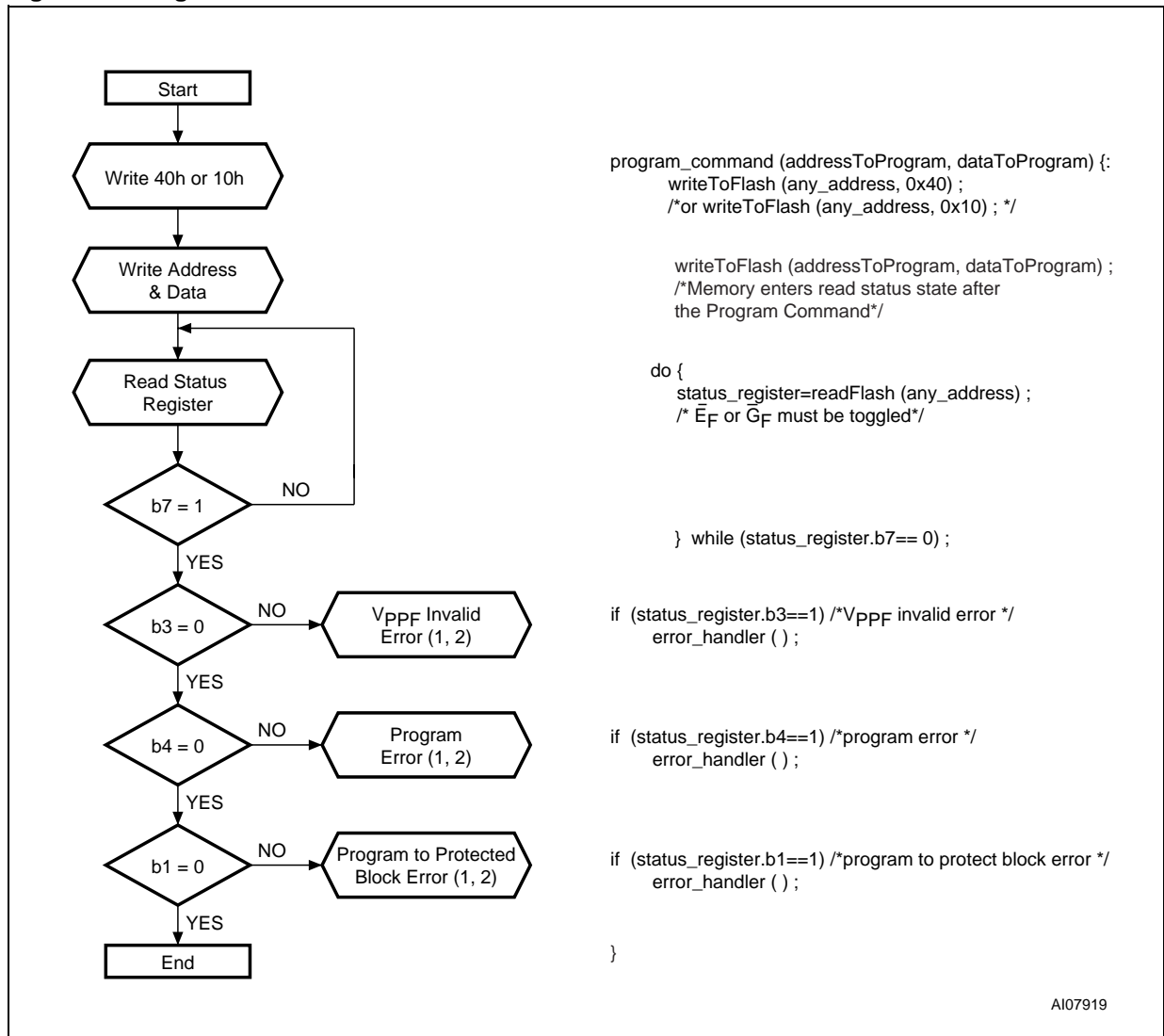

Note: 1. Status check of b1 (Protected Block), b3 (V_{PPF} Invalid) and b4 (Program Error) can be made after each program operation or after a sequence.
 2. If an error is found, the Status Register must be cleared before further Program/Erase Controller operations.

Figure 26. Double Word Program Flowchart and Pseudo Code

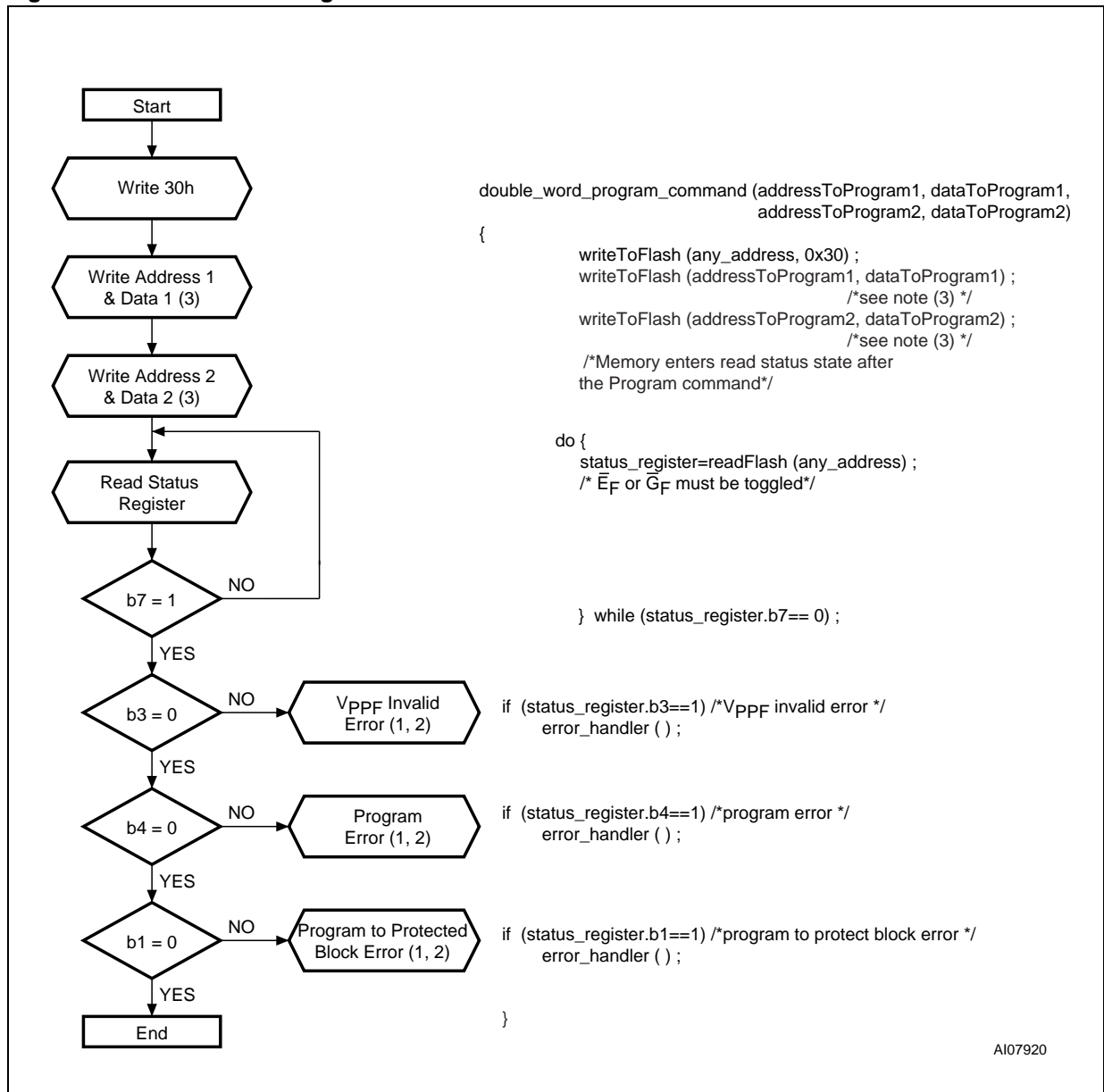

Note: 1. Status check of b1 (Protected Block), b3 (VppF Invalid) and b4 (Program Error) can be made after each program operation or after a sequence.

2. If an error is found, the Status Register must be cleared before further Program/Erase operations.
3. Address 1 and Address 2 must be consecutive addresses differing only for bit A0.

Figure 27. Program Suspend & Resume Flowchart and Pseudo Code

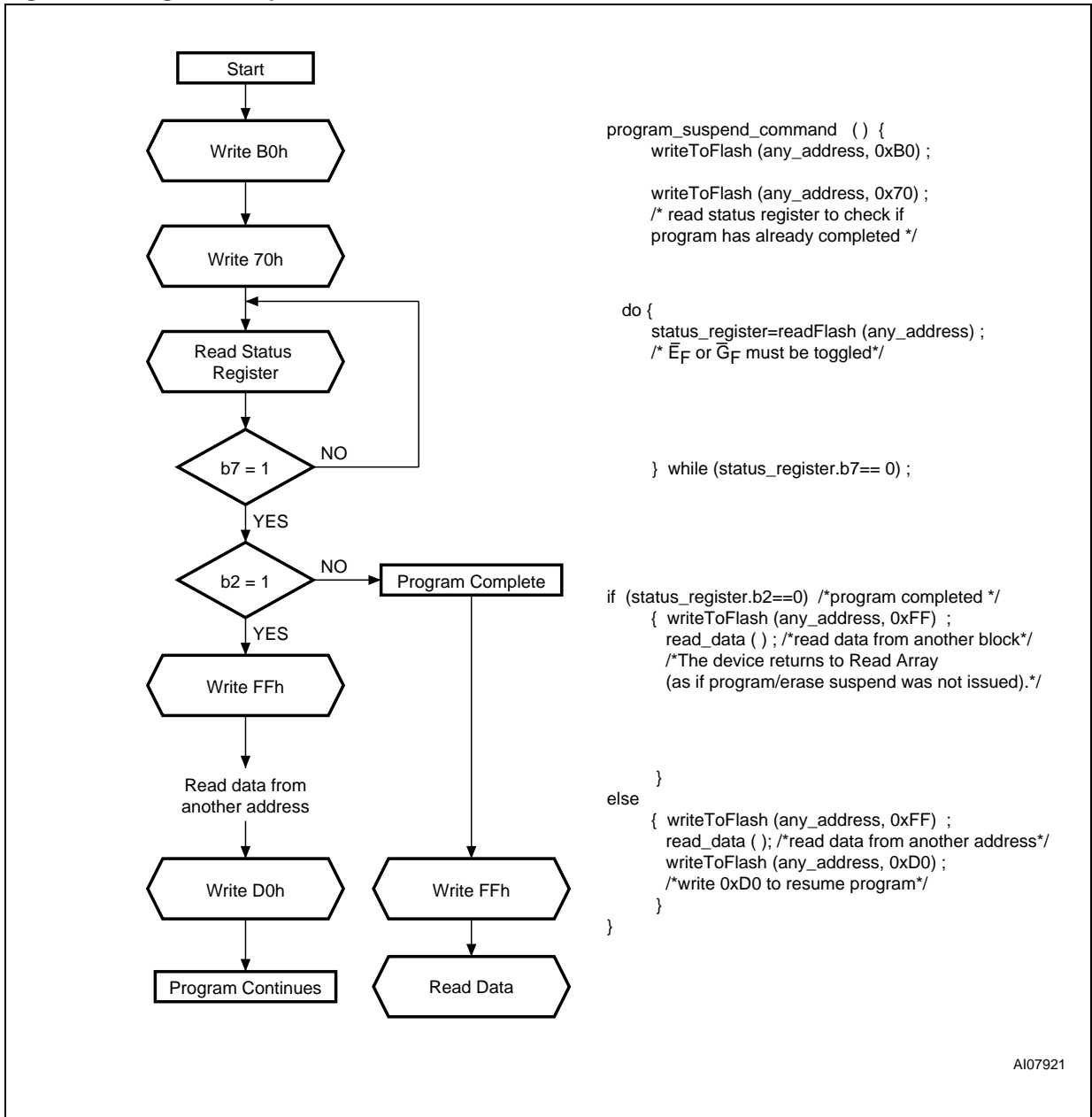

AI07921

Figure 28. Erase Flowchart and Pseudo Code

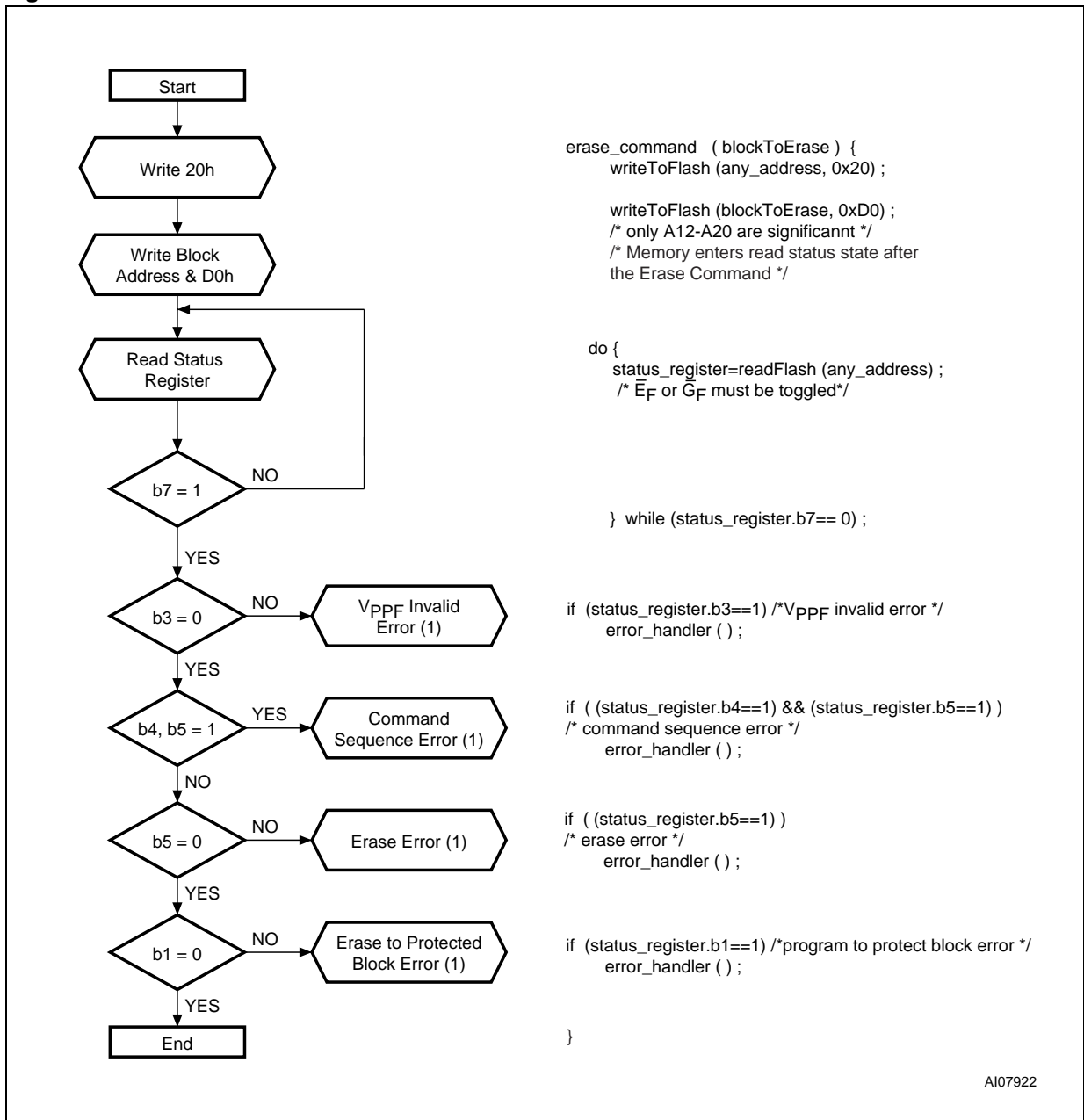

Note: If an error is found, the Status Register must be cleared before further Program/Erase operations.

Figure 29. Erase Suspend & Resume Flowchart and Pseudo Code

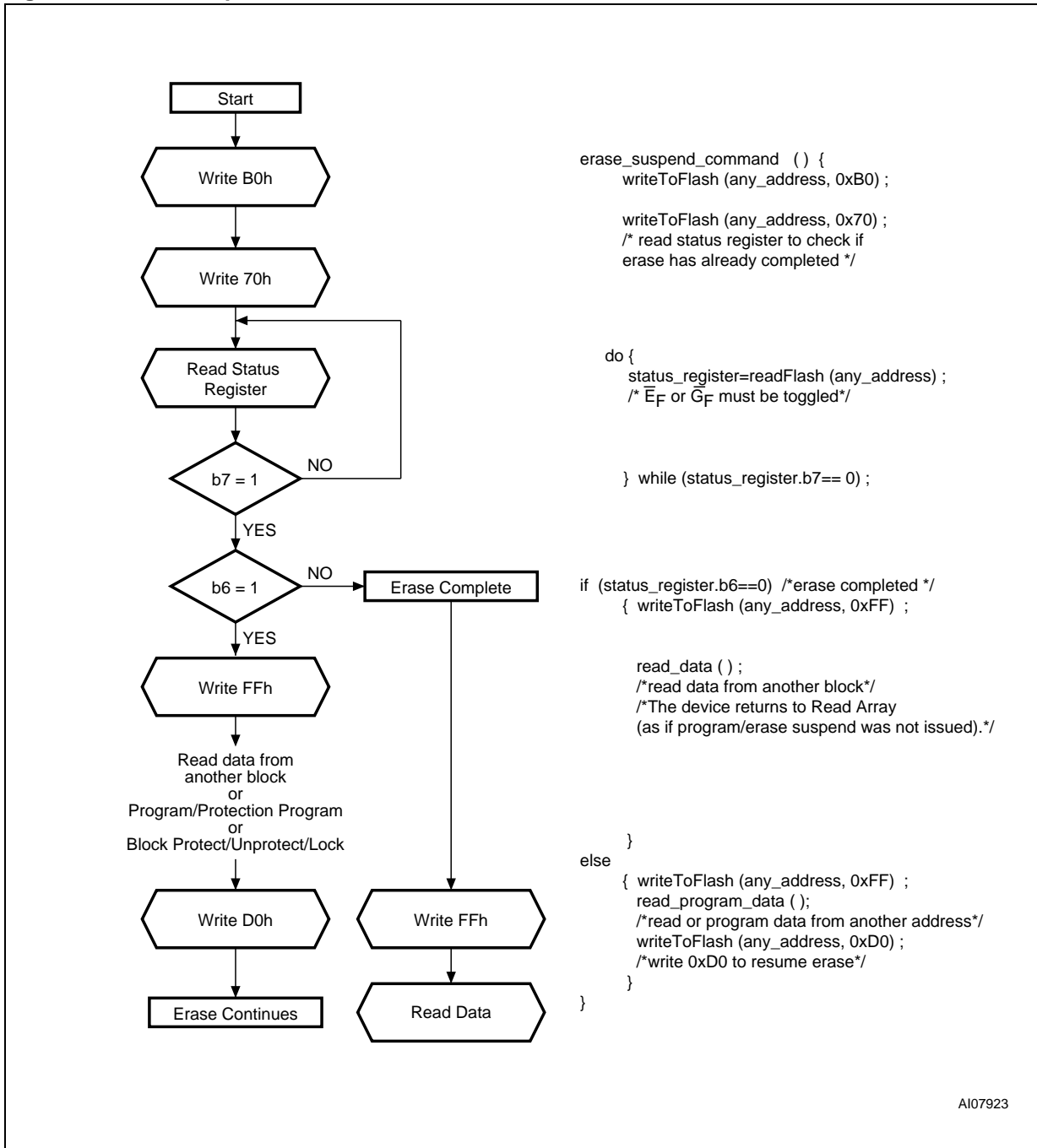

Figure 30. Locking Operations Flowchart and Pseudo Code

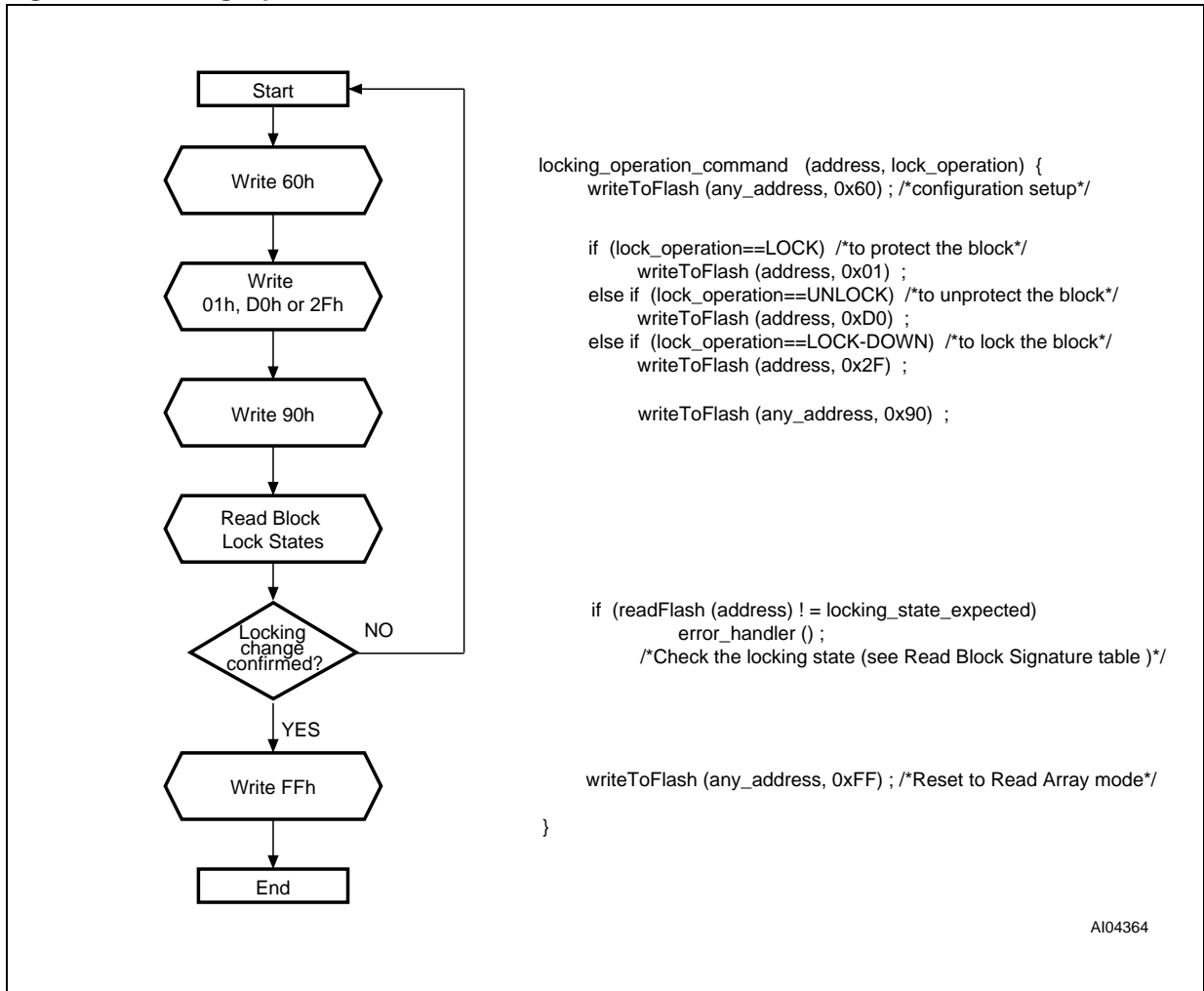
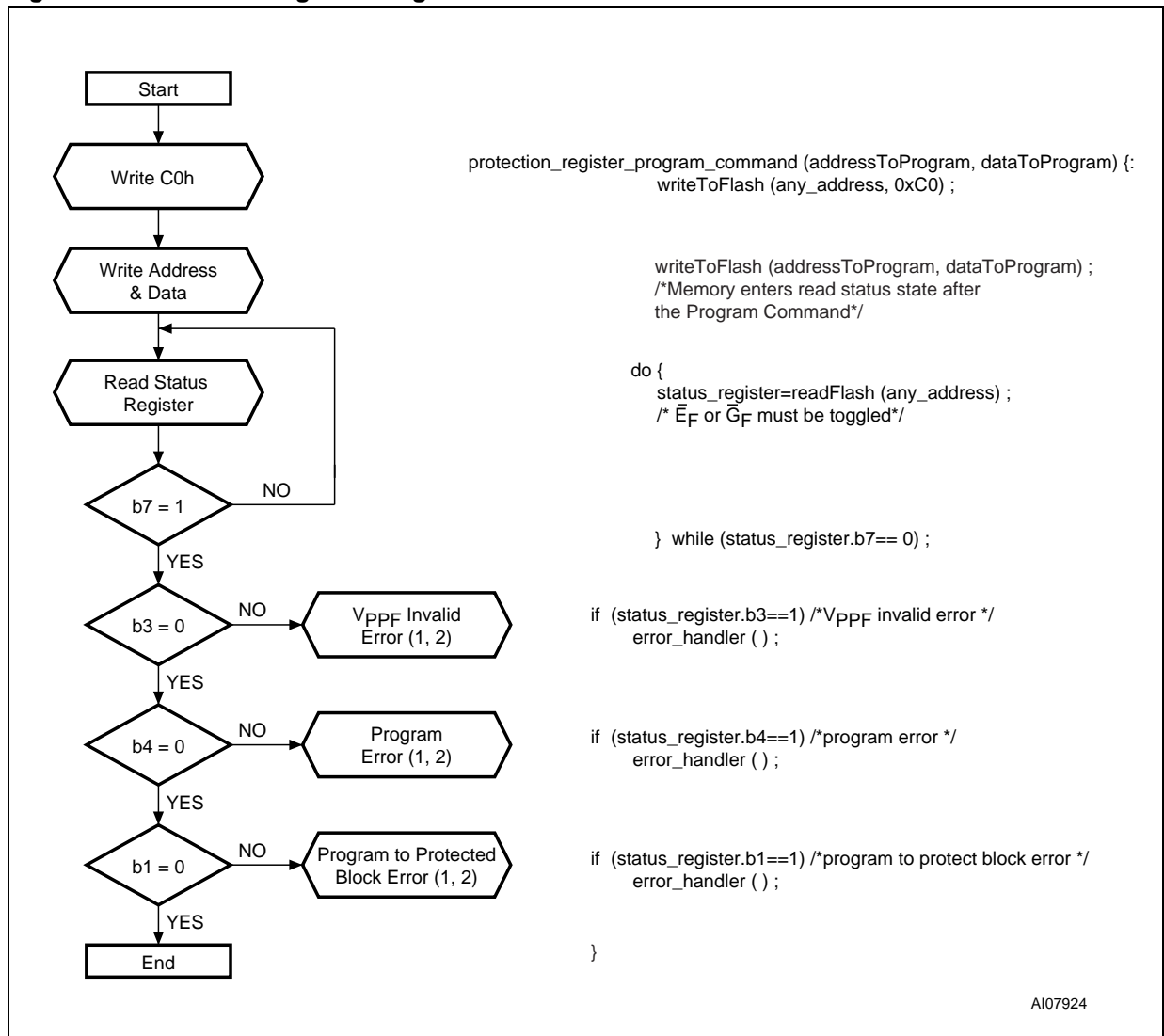

Figure 31. Protection Register Program Flowchart and Pseudo Code



Note: 1. Status check of b1 (Protected Block), b3 (VppF Invalid) and b4 (Program Error) can be made after each program operation or after a sequence.
 2. If an error is found, the Status Register must be cleared before further Program/Erase Controller operations.

APPENDIX D. COMMAND INTERFACE AND PROGRAM/ERASE CONTROLLER STATE

Table 33. Write State Machine Current/Next, sheet 1 of 2.

Current State	SR bit 7	Data When Read	Command Input (and Next State)								
			Read Array (FFh)	Program Setup (10/40h)	Erase Setup (20h)	Erase Confirm (D0h)	Prog/Ers Suspend (B0h)	Prog/Ers Resume (D0h)	Read Status (70h)	Clear Status (50h)	
Read Array	"1"	Array	Read Array	Prog. Setup	Ers. Setup	Read Array			Read Sts.	Read Array	
Read Status	"1"	Status	Read Array	Program Setup	Erase Setup	Read Array			Read Status	Read Array	
Read Elect.Sg.	"1"	Electronic Signature	Read Array	Program Setup	Erase Setup	Read Array			Read Status	Read Array	
Read CFI Query	"1"	CFI	Read Array	Program Setup	Erase Setup	Read Array			Read Status	Read Array	
Lock Setup	"1"	Status	Lock Command Error			Lock (complete)	Lock Cmd Error	Lock (complete)	Lock Command Error		
Lock Cmd Error	"1"	Status	Read Array	Program Setup	Erase Setup	Read Array			Read Status	Read Array	
Lock (complete)	"1"	Status	Read Array	Program Setup	Erase Setup	Read Array			Read Status	Read Array	
Prot. Prog. Setup	"1"	Status	Protection Register Program								
Prot. Prog. (continue)	"0"	Status	Protection Register Program continue								
Prot. Prog. (complete)	"1"	Status	Read Array	Program Setup	Erase Setup	Read Array			Read Status	Read Array	
Prog. Setup	"1"	Status	Program								
Program (continue)	"0"	Status	Program (continue)				Prog. Sus Read Sts	Program (continue)			
Prog. Sus Status	"1"	Status	Prog. Sus Read Array	Program Suspend to Read Array	Program (continue)	Prog. Sus Read Array	Program (continue)	Prog. Sus Read Sts	Prog. Sus Read Array		
Prog. Sus Read Array	"1"	Array	Prog. Sus Read Array	Program Suspend to Read Array	Program (continue)	Prog. Sus Read Array	Program (continue)	Prog. Sus Read Sts	Prog. Sus Read Array		
Prog. Sus Read Elect.Sg.	"1"	Electronic Signature	Prog. Sus Read Array	Program Suspend to Read Array	Program (continue)	Prog. Sus Read Array	Program (continue)	Prog. Sus Read Sts	Prog. Sus Read Array		
Prog. Sus Read CFI	"1"	CFI	Prog. Sus Read Array	Program Suspend to Read Array	Program (continue)	Prog. Sus Read Array	Program (continue)	Prog. Sus Read Sts	Prog. Sus Read Array		
Program (complete)	"1"	Status	Read Array	Program Setup	Erase Setup	Read Array			Read Status	Read Array	
Erase Setup	"1"	Status	Erase Command Error			Erase (continue)	Erase CmdError	Erase (continue)	Erase Command Error		
Erase Cmd.Error	"1"	Status	Read Array	Program Setup	Erase Setup	Read Array			Read Status	Read Array	
Erase (continue)	"0"	Status	Erase (continue)				Erase Sus Read Sts	Erase (continue)			
Erase Sus Read Sts	"1"	Status	Erase Sus Read Array	Program Setup	Erase Sus Read Array	Erase (continue)	Erase Sus Read Array	Erase (continue)	Erase Sus Read Sts	Erase Sus Read Array	
Erase Sus Read Array	"1"	Array	Erase Sus Read Array	Program Setup	Erase Sus Read Array	Erase (continue)	Erase Sus Read Array	Erase (continue)	Erase Sus Read Sts	Erase Sus Read Array	
Erase Sus Read Elect.Sg.	"1"	Electronic Signature	Erase Sus Read Array	Program Setup	Erase Sus Read Array	Erase (continue)	Erase Sus Read Array	Erase (continue)	Erase Sus Read Sts	Erase Sus Read Array	
Erase Sus Read CFI	"1"	CFI	Erase Sus Read Array	Program Setup	Erase Sus Read Array	Erase (continue)	Erase Sus Read Array	Erase (continue)	Erase Sus Read Sts	Erase Sus Read Array	
Erase (complete)	"1"	Status	Read Array	Program Setup	Erase Setup	Read Array			Read Status	Read Array	

Note: Cmd = Command, Elect.Sg. = Electronic Signature, Ers = Erase, Prog. = Program, Prot = Protection, Sus = Suspend.

Table 34. Write State Machine Current/Next, sheet 2 of 2.

Current State	Command Input (and Next State)						
	Read Elect.Sg. (90h)	Read CFI Query (98h)	Lock Setup (60h)	Prot. Prog. Setup (C0h)	Lock Confirm (01h)	Lock Down Confirm (2Fh)	Unlock Confirm (D0h)
Read Array	Read Elect.Sg.	Read CFI Query	Lock Setup	Prot. Prog. Setup	Read Array		
Read Status	Read Elect.Sg.	Read CFI Query	Lock Setup	Prot. Prog. Setup	Read Array		
Read Elect.Sg.	Read Elect.Sg.	Read CFI Query	Lock Setup	Prot. Prog. Setup	Read Array		
Read CFI Query	Read Elect.Sg.	Read CFI Query	Lock Setup	Prot. Prog. Setup	Read Array		
Lock Setup	Lock Command Error				Lock (complete)		
Lock Cmd Error	Read Elect.Sg.	Read CFI Query	Lock Setup	Prot. Prog. Setup	Read Array		
Lock (complete)	Read Elect.Sg.	Read CFI Query	Lock Setup	Prot. Prog. Setup	Read Array		
Prot. Prog. Setup	Protection Register Program						
Prot. Prog. (continue)	Protection Register Program (continue)						
Prot. Prog. (complete)	Read Elect.Sg.	Read CFI Query	Lock Setup	Prot. Prog. Setup	Read Array		
Prog. Setup	Program						
Program (continue)	Program (continue)						
Prog. Suspend Read Status	Prog. Suspend Read Elect.Sg.	Prog. Suspend Read CFI Query	Program Suspend Read Array				Program (continue)
Prog. Suspend Read Array	Prog. Suspend Read Elect.Sg.	Prog. Suspend Read CFI Query	Program Suspend Read Array				Program (continue)
Prog. Suspend Read Elect.Sg.	Prog. Suspend Read Elect.Sg.	Prog. Suspend Read CFI Query	Program Suspend Read Array				Program (continue)
Prog. Suspend Read CFI	Prog. Suspend Read Elect.Sg.	Prog. Suspend Read CFI Query	Program Suspend Read Array				Program (continue)
Program (complete)	Read Elect.Sg.	Read CFIQuery	Lock Setup	Prot. Prog. Setup	Read Array		
Erase Setup	Erase Command Error					Erase (continue)	
Erase Cmd.Error	Read Elect.Sg.	Read CFI Query	Lock Setup	Prot. Prog. Setup	Read Array		
Erase (continue)	Erase (continue)						
Erase Suspend Read Status	Erase Suspend Read Elect.Sg.	Erase Suspend Read CFI Query	Lock Setup	Erase Suspend Read Array			Erase (continue)
Erase Suspend Read Array	Erase Suspend Read Elect.Sg.	Erase Suspend Read CFI Query	Lock Setup	Erase Suspend Read Array			Erase (continue)
Erase Suspend Read Elect.Sg.	Erase Suspend Read Elect.Sg.	Erase Suspend Read CFI Query	Lock Setup	Erase Suspend Read Array			Erase (continue)
Erase Suspend Read CFI Query	Erase Suspend Read Elect.Sg.	Erase Suspend Read CFI Query	Lock Setup	Erase Suspend Read Array			Erase (continue)
Erase (complete)	Read Elect.Sg.	Read CFI Query	Lock Setup	Prot. Prog. Setup	Read Array		

Note: Cmd = Command, Elect.Sg. = Electronic Signature, Prog. = Program, Prot = Protection.



REVISION HISTORY

Table 35. Document Revision History

Date	Version	Revision Details
19-Nov-2002	1.0	First Issue

Information furnished is believed to be accurate and reliable. However, STMicroelectronics assumes no responsibility for the consequences of use of such information nor for any infringement of patents or other rights of third parties which may result from its use. No license is granted by implication or otherwise under any patent or patent rights of STMicroelectronics. Specifications mentioned in this publication are subject to change without notice. This publication supersedes and replaces all information previously supplied. STMicroelectronics products are not authorized for use as critical components in life support devices or systems without express written approval of STMicroelectronics.

The ST logo is registered trademark of STMicroelectronics
All other names are the property of their respective owners

© 2002 STMicroelectronics - All Rights Reserved

STMicroelectronics group of companies
Australia - Brazil - Canada - China - Finland - France - Germany - Hong Kong -
India - Israel - Italy - Japan - Malaysia - Malta - Morocco - Singapore - Spain - Sweden - Switzerland - United Kingdom - United States.
www.st.com