

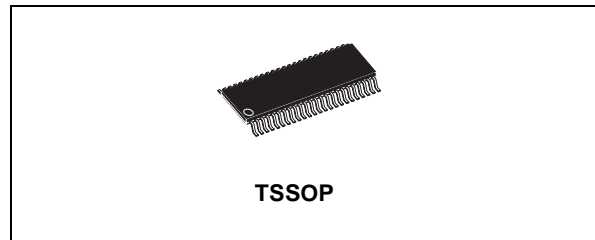

# 74AC16374

## 16-BIT D-TYPE FLIP-FLOP WITH 3-STATE OUTPUTS (NON INVERTED)

- HIGH SPEED:  
 $f_{MAX} = 120\text{MHz}$  (TYP.) at  $V_{CC} = 5\text{V}$
- LOW POWER DISSIPATION:  
 $I_{CC} = 8\mu\text{A}$ (MAX.) at  $T_A=25^\circ\text{C}$
- HIGH NOISE IMMUNITY:  
 $V_{NIH} = V_{NIL} = 28\% V_{CC}$  (MIN.)
- 50Ω TRANSMISSION LINE DRIVING CAPABILITY
- SYMMETRICAL OUTPUT IMPEDANCE:  
 $|I_{OH}| = I_{OL} = 24\text{mA}$  (MIN)
- OPERATING VOLTAGE RANGE:  
 $V_{CC}$  (OPR) = 2V to 6V
- IMPROVED LATCH-UP IMMUNITY



### ORDER CODES

PACKAGE	TUBE	T & R
TSSOP		74AC16374TTR

### DESCRIPTION

The 74AC16374 is an advanced high-speed CMOS 16-BIT D-TYPE FLIP-FLOP (3-STATE) fabricated with sub-micron silicon gate and double-layer metal wiring C<sup>2</sup>MOS technology.

This 16 bit D-Type Flip-Flop is controlled by two clock inputs (CK) and two output enable inputs ( $\overline{OE}$ ). The device can be used as two 8-bit flip-flops or one 16-bit flip-flop.

On the positive transition of the clock, the Q outputs will be set to the logic state that were setup at the D inputs.

While the ( $\overline{OE}$ ) input is low, the outputs will be in a normal logic state (high or low logic level); while  $\overline{OE}$  is high, the outputs will be in a high impedance state.

The output control does not affect the internal operation of flip-flops; that is, the old data can be retained or the new data can be entered even while the outputs are off.

All inputs and outputs are equipped with protection circuits against static discharge, giving them 2KV ESD immunity and transient excess voltage.

### PIN CONNECTION

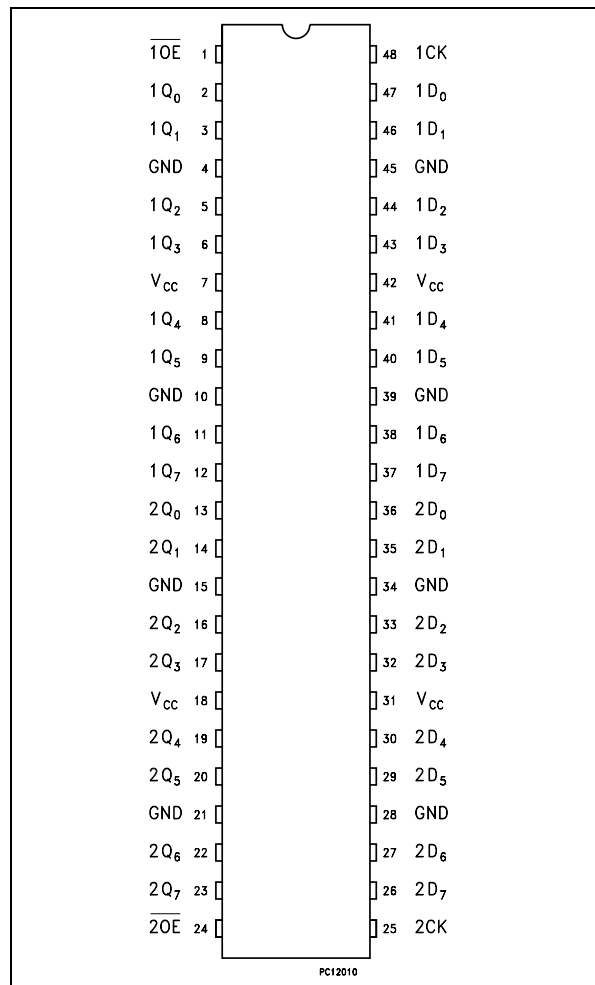

INPUT AND OUTPUT EQUIVALENT CIRCUIT

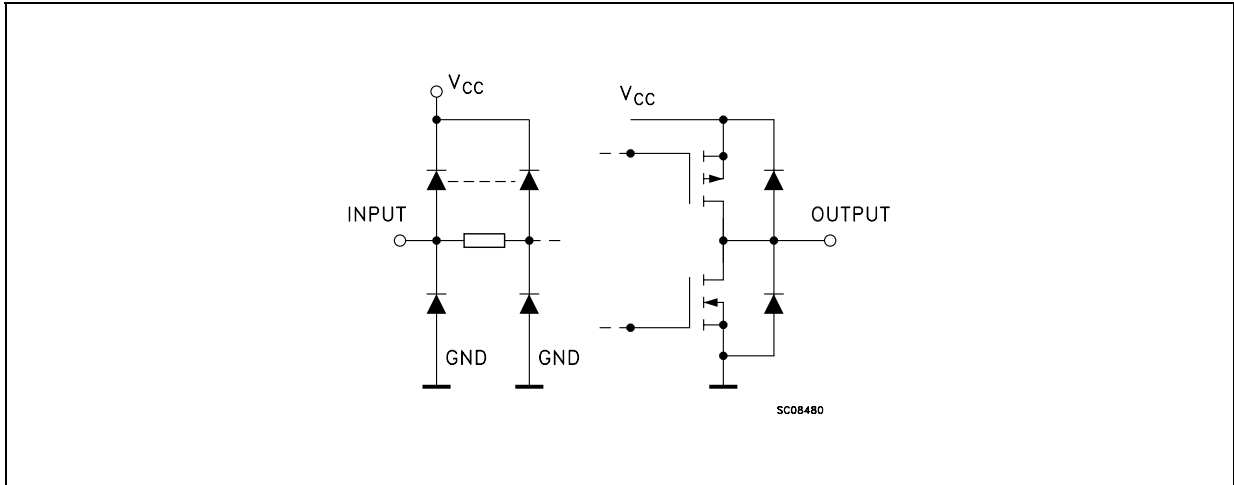

PIN DESCRIPTION

PIN No	SYMBOL	NAME AND FUNCTION
1	1OE	3 State Output Enable Input (Active LOW)
2, 3, 5, 6, 8, 9, 11, 12	1Q0 to 1Q7	3-State Outputs
13, 14, 16, 17, 19, 20, 22, 23	2Q0 to 2Q7	3-State Outputs
24	2OE	3 State Output Enable Input (Active LOW)
25	2CK	Clock Input (LOW-to-HIGH Edge Trigger)
36, 35, 33, 32, 30, 29, 27, 26	2D0 to 2D7	Data Inputs
47, 46, 44, 43, 41, 40, 38, 37	1D0 to 1D7	Data Inputs
48	1CK	Clock Input (LOW-to-HIGH Edge Trigger)
4, 10, 15, 21, 28, 34, 39, 45	GND	Ground (0V)
7, 18, 31, 42	V <sub>CC</sub>	Positive Supply Voltage

IEC LOGIC SYMBOLS

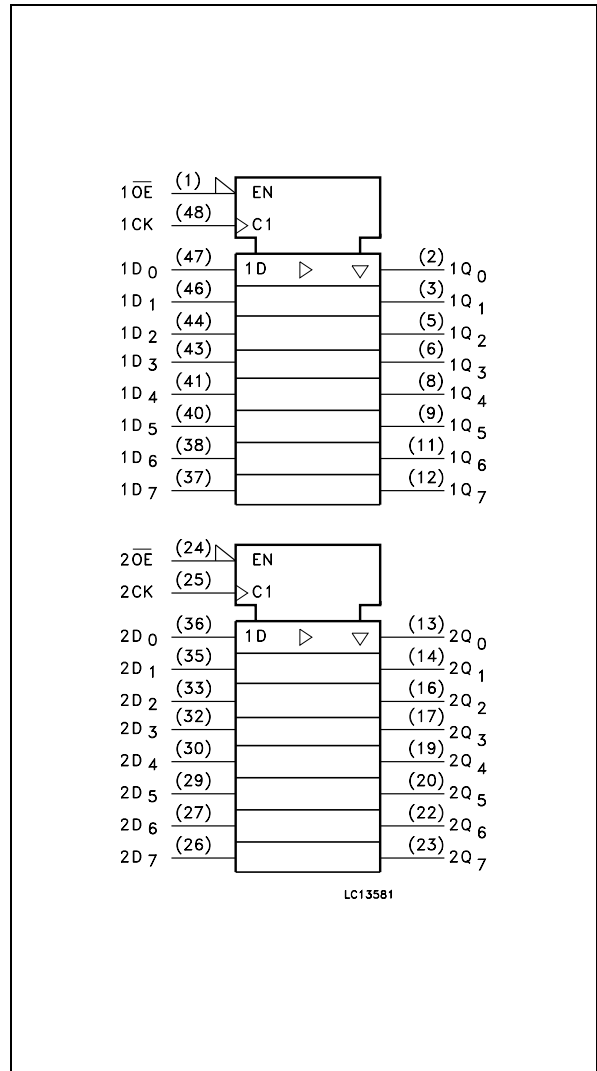

TRUTH TABLE

INPUTS			OUTPUTS
$\overline{OE}$	CK	D	Q
H	X	X	Z
L		X	NO CHANGE
L		L	L
L		H	H

X : Don't Care  
Z : High Impedance

## LOGIC DIAGRAM

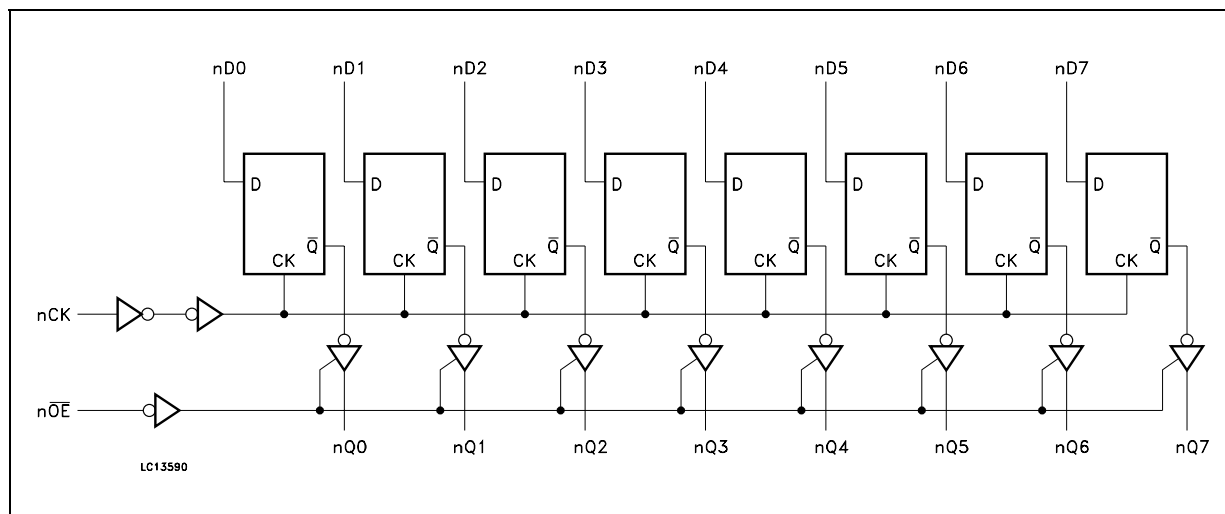

This logic diagram has not to be used to estimate propagation delays

## ABSOLUTE MAXIMUM RATINGS

Symbol	Parameter	Value	Unit
$V_{CC}$	Supply Voltage	-0.5 to +7	V
$V_I$	DC Input Voltage	-0.5 to $V_{CC} + 0.5$	V
$V_O$	DC Output Voltage	-0.5 to $V_{CC} + 0.5$	V
$I_{IK}$	DC Input Diode Current	$\pm 20$	mA
$I_{OK}$	DC Output Diode Current	$\pm 20$	mA
$I_O$	DC Output Current	$\pm 50$	mA
$I_{CC}$ or $I_{GND}$	DC $V_{CC}$ or Ground Current	$\pm 400$	mA
$T_{stg}$	Storage Temperature	-65 to +150	$^{\circ}C$
$T_L$	Lead Temperature (10 sec)	300	$^{\circ}C$

Absolute Maximum Ratings are those values beyond which damage to the device may occur. Functional operation under these conditions is not implied.

## RECOMMENDED OPERATING CONDITIONS

Symbol	Parameter	Value	Unit
$V_{CC}$	Supply Voltage	2 to 6	V
$V_I$	Input Voltage	0 to $V_{CC}$	V
$V_O$	Output Voltage	0 to $V_{CC}$	V
$T_{op}$	Operating Temperature	-55 to 125	$^{\circ}C$
dt/dv	Input Rise and Fall Time $V_{CC} = 3.0, 4.5$ or $5.5V$ (note 1)	8	ns/V

1)  $V_{IN}$  from 30% to 70% of  $V_{CC}$

## DC SPECIFICATIONS

Symbol	Parameter	Test Condition		Value						Unit	
		V <sub>CC</sub> (V)		T <sub>A</sub> = 25 °C			-40 to 85°C		-55 to 125°C		
				Min.	Typ.	Max.	Min.	Max.	Min.		Max.
V <sub>IH</sub>	High Level Input Voltage	3.0	V <sub>O</sub> = 0.1 V or V <sub>CC</sub> -0.1V	2.1	1.5		2.1		2.1		V
		4.5		3.15	2.25		3.15		3.15		
		5.5		3.85	2.75		3.85		3.85		
V <sub>IL</sub>	Low Level Input Voltage	3.0	V <sub>O</sub> = 0.1 V or V <sub>CC</sub> -0.1V		1.5	0.9		0.9		0.9	V
		4.5			2.25	1.35		1.35		1.35	
		5.5			2.75	1.65		1.65		1.65	
V <sub>OH</sub>	High Level Output Voltage	3.0	I <sub>O</sub> =-50 μA	2.9	2.99		2.9		2.9		V
		4.5	I <sub>O</sub> =-50 μA	4.4	4.49		4.4		4.4		
		5.5	I <sub>O</sub> =-50 μA	5.4	5.49		5.4		5.4		
		3.0	I <sub>O</sub> =-12 mA	2.56			2.46		2.46		
		4.5	I <sub>O</sub> =-24 mA	3.86			3.76		3.76		
		5.5	I <sub>O</sub> =-24 mA	4.86			4.76		4.76		
V <sub>OL</sub>	Low Level Output Voltage	3.0	I <sub>O</sub> =50 μA		0.002	0.1		0.1		0.1	V
		4.5	I <sub>O</sub> =50 μA		0.001	0.1		0.1		0.1	
		5.5	I <sub>O</sub> =50 μA		0.001	0.1		0.1		0.1	
		3.0	I <sub>O</sub> =12 mA			0.36		0.44		0.44	
		4.5	I <sub>O</sub> =24 mA			0.36		0.44		0.44	
		5.5	I <sub>O</sub> =24 mA			0.36		0.44		0.44	
I <sub>I</sub>	Input Leakage Current	5.5	V <sub>I</sub> = V <sub>CC</sub> or GND			± 0.1		± 1		± 1	μA
I <sub>OZ</sub>	High Impedance Output Leakage Current	5.5	V <sub>I</sub> = V <sub>IH</sub> or V <sub>IL</sub> V <sub>O</sub> = V <sub>CC</sub> or GND			± 0.5		± 5		± 5	μA
I <sub>CC</sub>	Quiescent Supply Current	5.5	V <sub>I</sub> = V <sub>CC</sub> or GND			8		80		80	μA
I <sub>OLD</sub>	Dynamic Output Current (note 1, 2)	5.5	V <sub>OLD</sub> = 1.65 V max					75		75	mA
I <sub>OHD</sub>			V <sub>OHD</sub> = 3.85 V min					-75		-75	mA

1) Maximum test duration 2ms, one output loaded at time

2) Incident wave switching is guaranteed on transmission lines with impedances as low as 50Ω

AC ELECTRICAL CHARACTERISTICS ( $C_L = 50 \text{ pF}$ ,  $R_L = 500 \Omega$ , Input  $t_r = t_f = 3\text{ns}$ )

Symbol	Parameter	Test Condition		Value						Unit	
		$V_{CC}$ (V)		$T_A = 25^\circ\text{C}$			$-40 \text{ to } 85^\circ\text{C}$		$-55 \text{ to } 125^\circ\text{C}$		
				Min.	Typ.	Max.	Min.	Max.	Min.		Max.
$t_{PLH}$ $t_{PHL}$	Propagation Delay Time CK to Q	3.3(*)			5.9	9.8		17.0		17.0	ns
		5.0(**)			4.2	6.5		10.8		10.8	
$t_{PZL}$ $t_{PZH}$	Output Enable Time	3.3(*)			6.7	11.1		21.2		21.2	ns
		5.0(**)			4.9	7.3		12.1		12.1	
$t_{PLZ}$ $t_{PHZ}$	Output Disable Time	3.3(*)			6.3	10.0		12.0		12.0	ns
		5.0(**)			4.9	7.6		9.1		9.1	
$t_W$	CLOCK Pulse Width HIGH or LOW	3.3(*)		2.5	2.0		5.2		5.2	ns	
		5.0(**)		2.5	2.0		4.2		4.2		
$t_s$	Setup Time D to CK, HIGH or LOW	3.3(*)		1.5	1.0		2.5		2.5	ns	
		5.0(**)		2.0	1.2		2.5		2.5		
$t_h$	Hold Time D to CK, HIGH or LOW	3.3(*)		1.0	-0.5		1.5		1.5	ns	
		5.0(**)		1.0	-0.5		1.5		1.5		
$f_{MAX}$	Maximum Clock Frequency	3.3(*)		60	100		60		60	MHz	
		5.0(**)		100	120		100		100		

(\*) Voltage range is  $3.3\text{V} \pm 0.3\text{V}$ (\*\*) Voltage range is  $5.0\text{V} \pm 0.5\text{V}$ 

## CAPACITIVE CHARACTERISTICS

Symbol	Parameter	Test Condition		Value						Unit	
		$V_{CC}$ (V)		$T_A = 25^\circ\text{C}$			$-40 \text{ to } 85^\circ\text{C}$		$-55 \text{ to } 125^\circ\text{C}$		
				Min.	Typ.	Max.	Min.	Max.	Min.		Max.
$C_{IN}$	Input Capacitance	5.0			3.5						pF
$C_{OUT}$	Output Capacitance	5.0			11						pF
$C_{PD}$	Power Dissipation Capacitance (note 1)	5.0	$f_{IN}=10\text{MHz}$		20						pF

1)  $C_{PD}$  is defined as the value of the IC's internal equivalent capacitance which is calculated from the operating current consumption without load. (Refer to Test Circuit). Average operating current can be obtained by the following equation.  $I_{CC(opr)} = C_{PD} \times V_{CC} \times f_{IN} + I_{CC}/16$  (per circuit)

TEST CIRCUIT

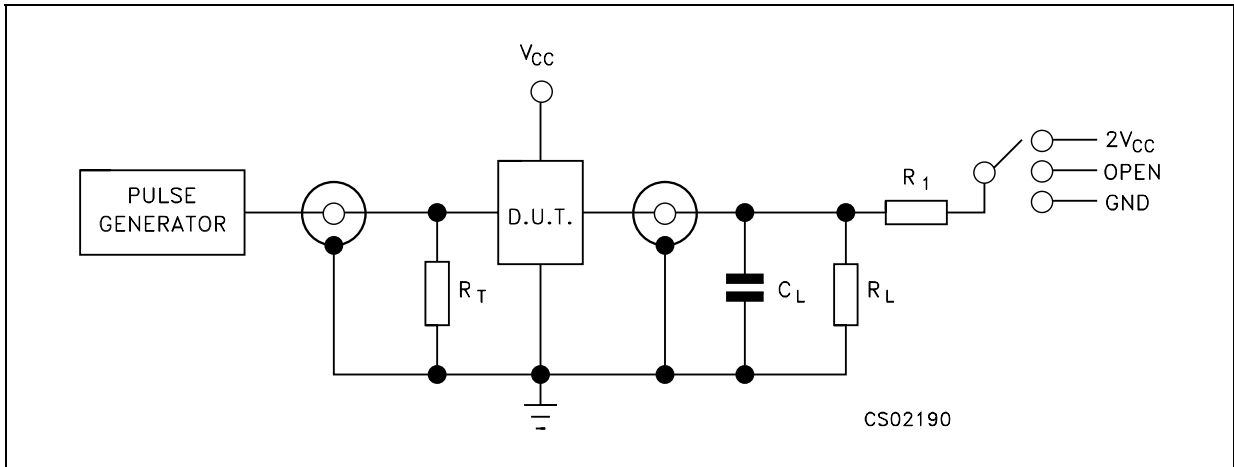

Test	Switch
$t_{PLH}$ , $t_{PHL}$	Open
$t_{PZL}$ , $t_{PLZ}$	$2V_{CC}$
$t_{PZH}$ , $t_{PHZ}$	GND

$C_L = 50\text{pF}$  or equivalent (includes jig and probe capacitance)  
 $R_L = R_1 = 500\Omega$  or equivalent  
 $R_T = Z_{OUT}$  of pulse generator (typically  $50\Omega$ )

WAVEFORM 1: PROPAGATION DELAYS, SETUP AND HOLD TIMES ( $f=1\text{MHz}$ ; 50% duty cycle)

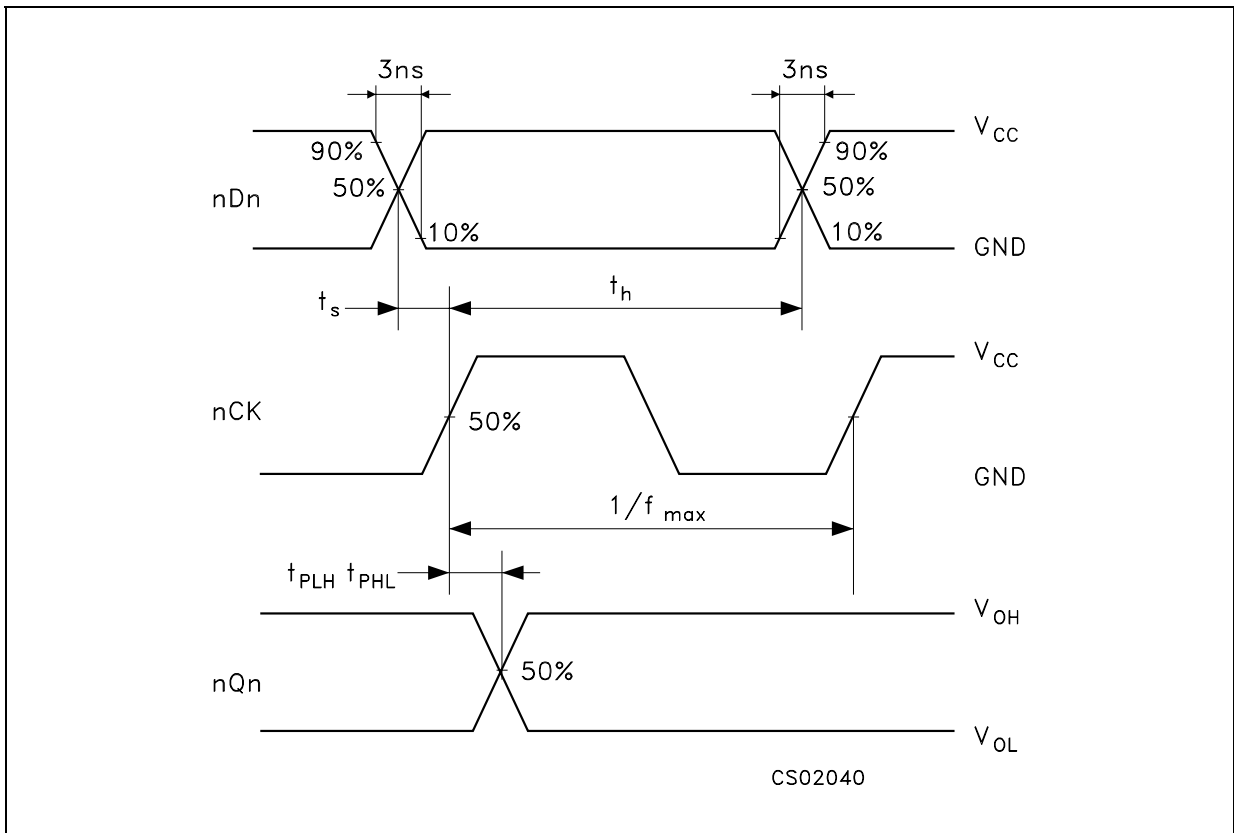

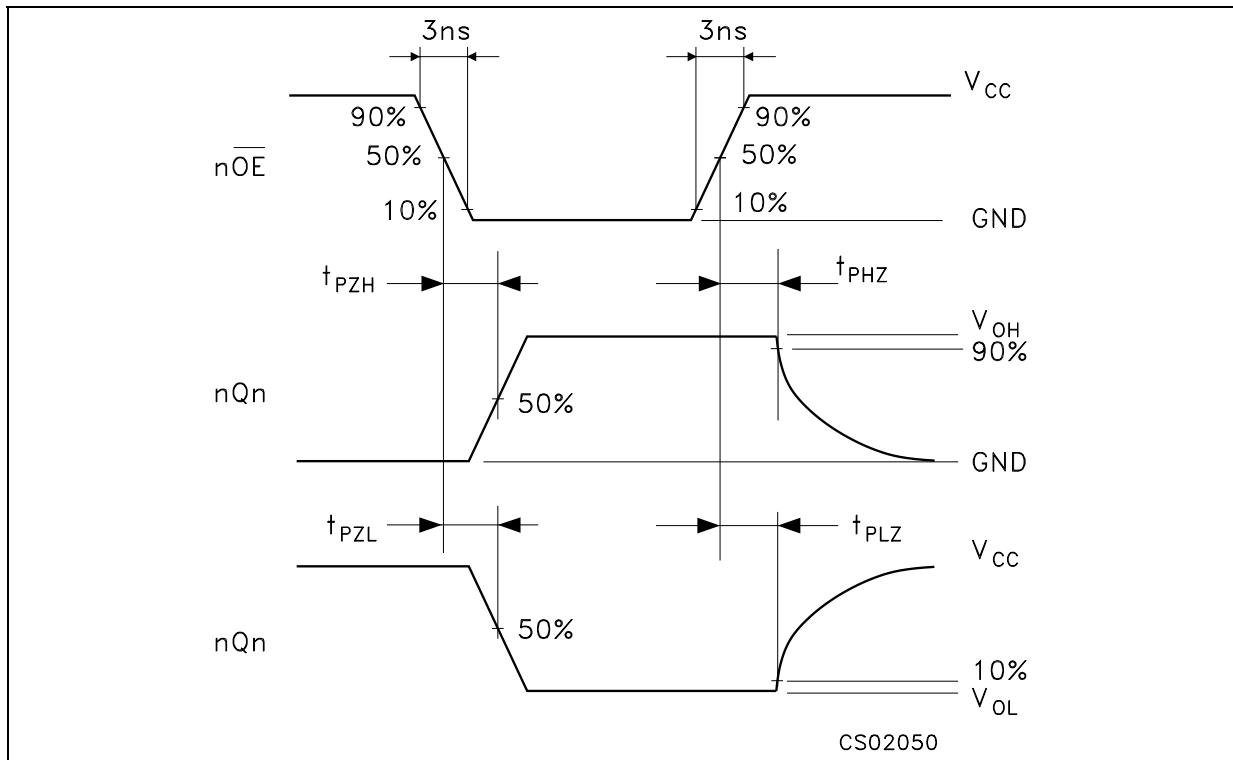
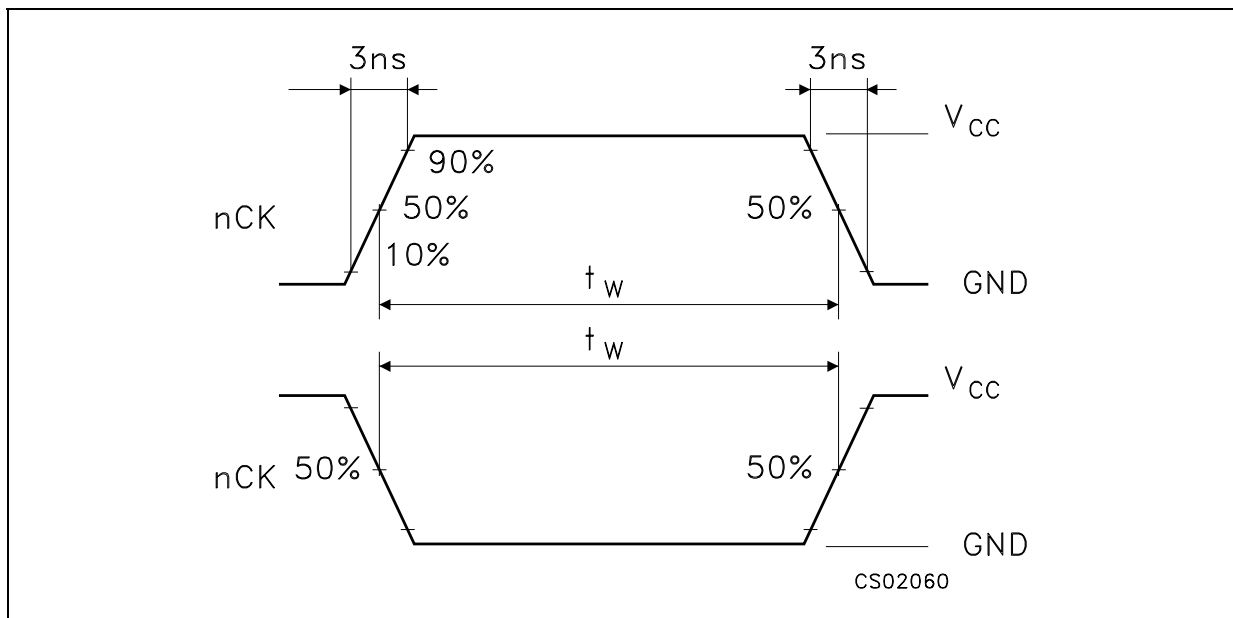
**WAVEFORM 2: OUTPUT ENABLE AND DISABLE TIMES** ( $f=1\text{MHz}$ ; 50% duty cycle)**WAVEFORM 3: CLOCK PULSE WIDTHS** ( $f=1\text{MHz}$ ; 50% duty cycle)

## TSSOP48 MECHANICAL DATA

DIM.	mm.			inch		
	MIN.	TYP.	MAX.	MIN.	TYP.	MAX.
A			1.2			0.047
A1	0.05		0.15	0.002		0.006
A2		0.9			0.035	
b	0.17		0.27	0.0067		0.011
c	0.09		0.20	0.0035		0.0079
D	12.4		12.6	0.488		0.496
E		8.1 BSC			0.318 BSC	
E1	6.0		6.2	0.236		0.244
e		0.5 BSC			0.0197 BSC	
K	0°		8°	0°		8°
L	0.50		0.75	0.020		0.030

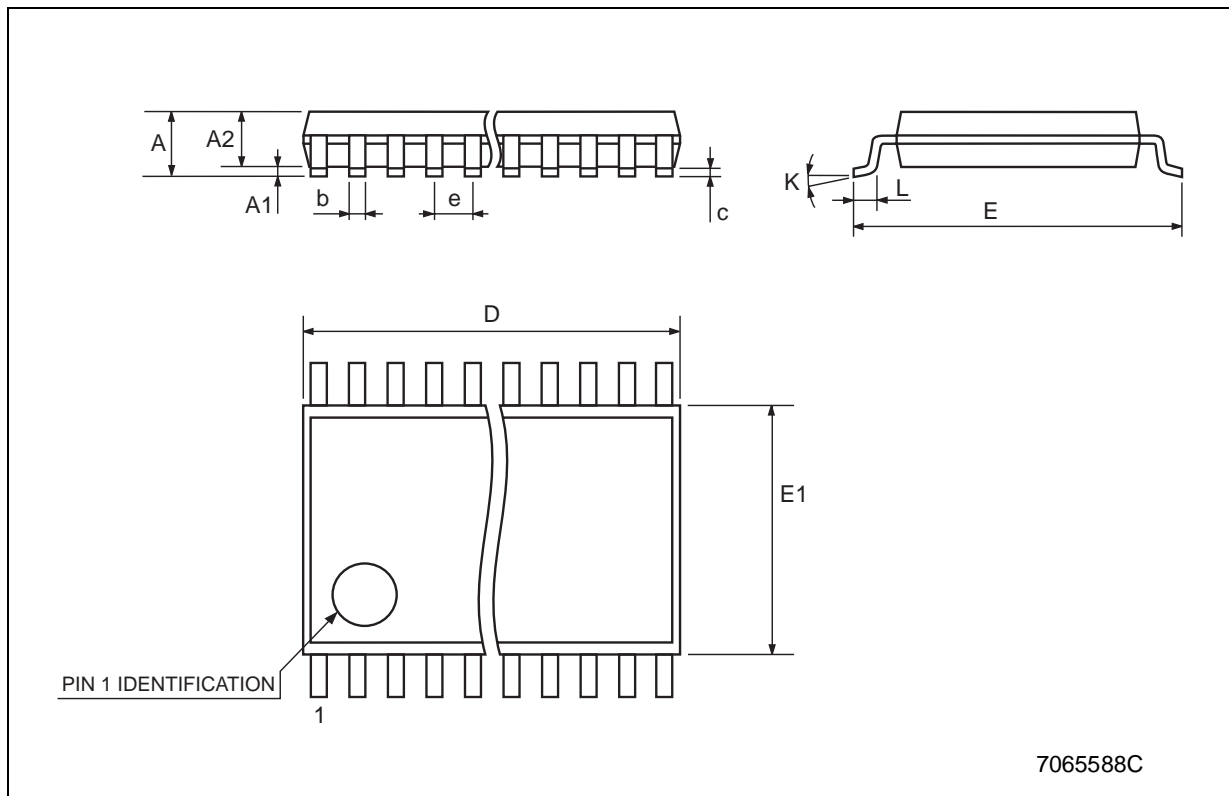



### Tape & Reel TSSOP48 MECHANICAL DATA

DIM.	mm.			inch		
	MIN.	TYP	MAX.	MIN.	TYP.	MAX.
A			330			12.992
C	12.8		13.2	0.504		0.519
D	20.2			0.795		
N	60			2.362		
T			30.4			1.197
Ao	8.7		8.9	0.343		0.350
Bo	13.1		13.3	0.516		0.524
Ko	1.5		1.7	0.059		0.067
Po	3.9		4.1	0.153		0.161
P	11.9		12.1	0.468		0.476

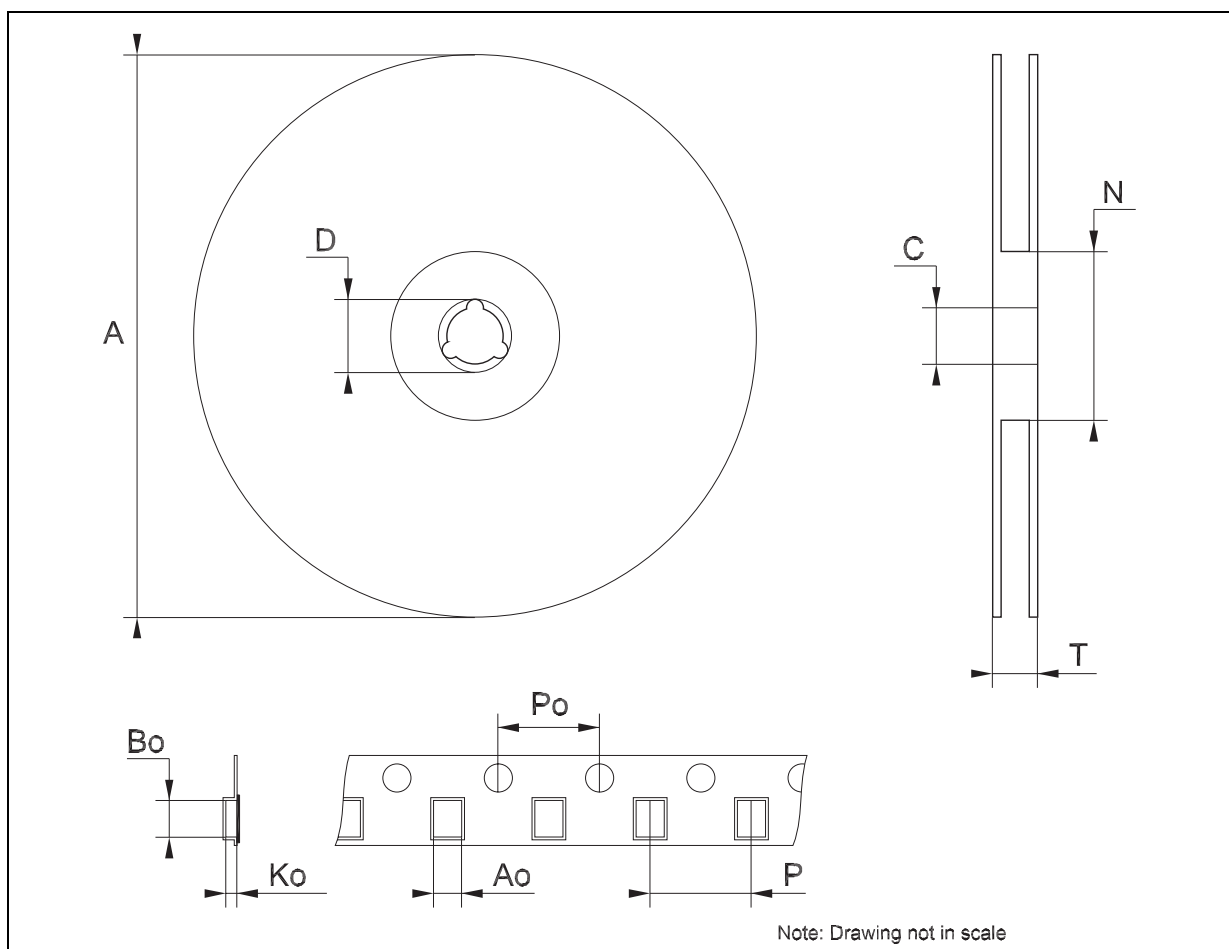

Information furnished is believed to be accurate and reliable. However, STMicroelectronics assumes no responsibility for the consequences of use of such information nor for any infringement of patents or other rights of third parties which may result from its use. No license is granted by implication or otherwise under any patent or patent rights of STMicroelectronics. Specifications mentioned in this publication are subject to change without notice. This publication supersedes and replaces all information previously supplied. STMicroelectronics products are not authorized for use as critical components in life support devices or systems without express written approval of STMicroelectronics.

© The ST logo is a registered trademark of STMicroelectronics

© 2003 STMicroelectronics - Printed in Italy - All Rights Reserved  
STMicroelectronics GROUP OF COMPANIES

Australia - Brazil - Canada - China - Finland - France - Germany - Hong Kong - India - Israel - Italy - Japan - Malaysia - Malta - Morocco  
Singapore - Spain - Sweden - Switzerland - United Kingdom - United States.

© <http://www.st.com>