



# TS636

## DIFFERENTIAL VARIABLE GAIN AMPLIFIER FOR ADSL LINE INTERFACE

- LOW NOISE : 4.7nV/√Hz
- LOW DISTORTION
- HIGH SLEW RATE : 90V/μs
- WIDE BANDWIDTH : 52MHz @ -3dB & 18dB gain
- GAIN PROGRAMMABLE from -9dB to +30dB with 3dB STEPS
- POWER DOWN FUNCTION

### DESCRIPTION

This TS636 is particularly intended for applications such as preamplification in telecommunication systems using multiple carriers. It has been mainly designed to fit with ADSL chip-sets such as ASCOT ADSL chip-set for CPE.

The TS636 is a differential digitally controlled variable gain amplifier featuring a high slew rate of 90V/μs, a large bandwidth, a very low distortion and a very low current and voltage noise.

The gain can be set from -9dB to +30dB through a 4bit digital word, with 3dB steps.

The gain monotonicity is guaranteed by design.

The TS636 comes in SO-14 plastic packages.

### APPLICATION

- Preamplifier with automatic gain control for Asymmetric Digital Subscriber Line (ADSL).

### ORDER CODE

Part Number	Temperature Range	Package
		D
TS636I	-40, +85°C	•

D = Small Outline Package (SO) - also available in Tape & Reel (DT)

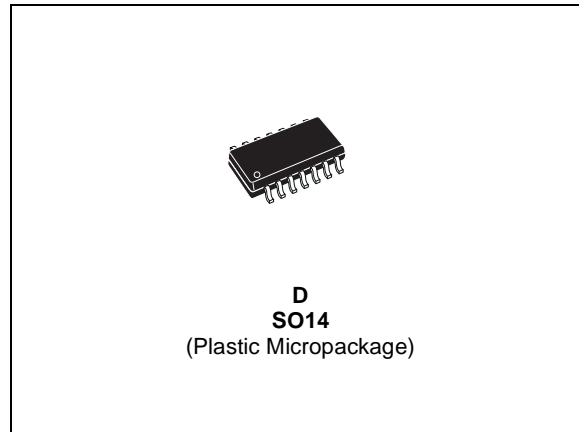

PIN CONNECTIONS (top view)

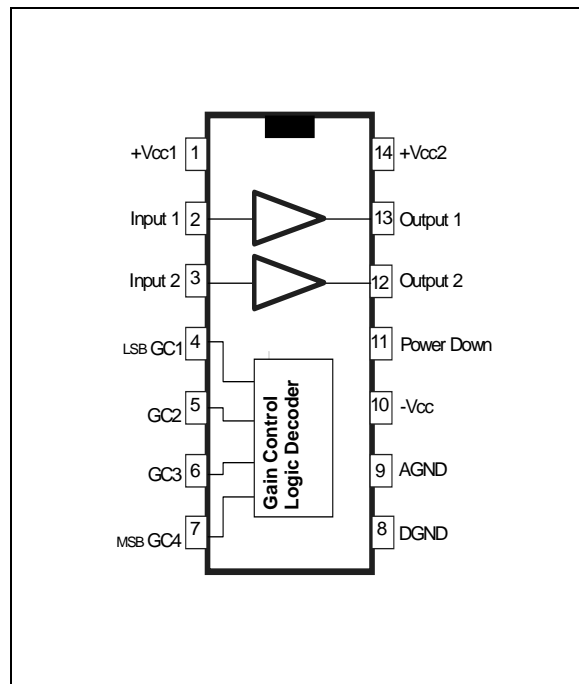

**ABSOLUTE MAXIMUM RATINGS**

Symbol	Parameter	Value	Unit
$V_{CC}$	Supply voltage <sup>1)</sup>	14	V
$V_i$	Input Voltage <sup>2)</sup>	0 to 14	V
$T_{oper}$	Operating Free Air Temperature Range TS636ID	-40 to + 85	°C
$T_{std}$	Storage Temperature	-65 to +150	°C
$T_j$	Maximum Junction Temperature	150	°C
$R_{thjc}$	Thermal Resistance Junction to Case	22	°C/W
$R_{thja}$	Thermal Resistance Junction to Ambiente Area	125	°C/W
	Output Short Circuit Duration	Infinite	

1. All voltages values are with respect to network terminal.
2. The magnitude of input and output voltages must never exceed  $V_{CC} + 0.3V$ .

**OPERATING CONDITIONS**

Symbol	Parameter	Value	Unit
$V_{CC}$	Supply Voltage	5 to 12	V
$V_{icm}$	Common Mode Input Voltage	$V_{CC}/2$	V

**APPLICATION: ADSL LINE INTERFACE**

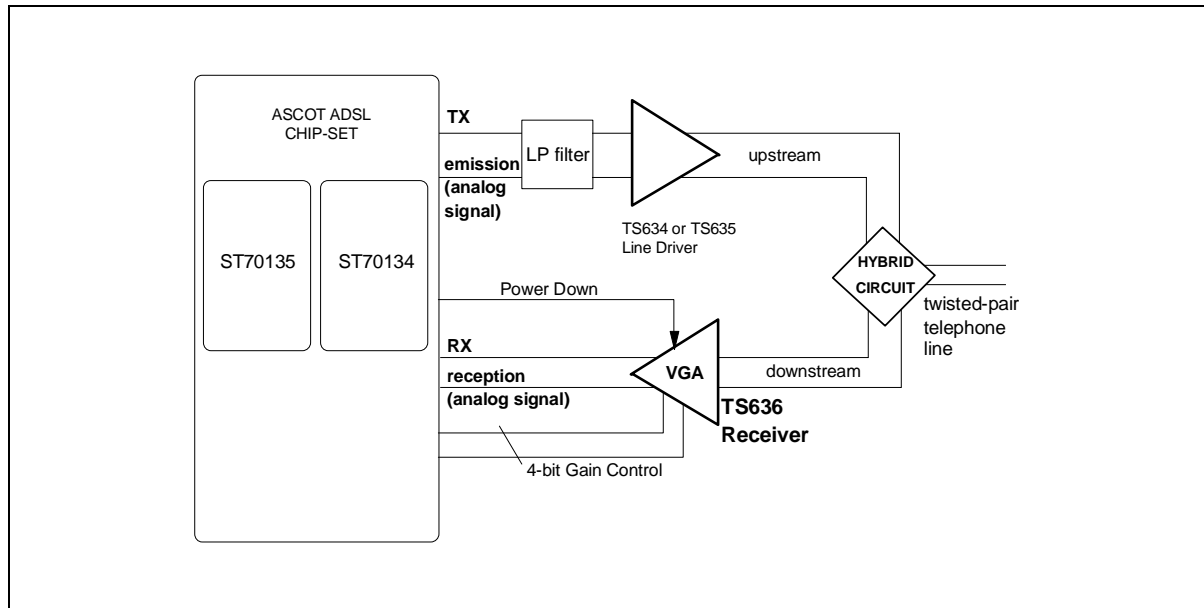

**ELECTRICAL CHARACTERISTICS.**  $V_{CC} = \pm 6\text{Volts}$ ,  $T_{amb} = 25^{\circ}\text{C}$  (unless otherwise specified).

Symbol	Parameter	Test Condition	Min.	Typ.	Max	Unit
<b>DC PERFORMANCE</b>						
$I_{ib}$	Input Bias Current (AGND pin)			8		$\mu\text{A}$
$I_{CC}$	Total Supply Current	No load, $V_{out} = 0$		28		mA
$\Delta V_{OFFSET}$	Differential Input Offset Voltage	$V_{in} = 0$ , $A_V = 30\text{dB}$			6	mV
SVR	Supply Voltage Rejection Ratio	$A_V = 0\text{dB}$	50	80		dB
<b>POWER DOWN MODE</b>						
$I_{ccpdw}$	Power Down Total Consumption	Power Down Mode			150	$\mu\text{A}$
$Z_{out}$	Power Down Output Impedance	Power Down Mode	100k $\Omega$	150k $\Omega$ /5pF		
<b>AC PERFORMANCE</b>						
$Z_{in}$	Input Impedance			100k $\Omega$ /5pF		
$V_{OH}$	High Level Output Voltage $R_L$ connected to GND	$R_L = 500\Omega$	4	4.5		V
$V_{OL}$	Low Level Output Voltage $R_L$ connected to GND	$R_L = 500\Omega$		-4.5	-4	V
$A_V$	Voltage Gain Gain monotonicity guaranteed by design	$F = 1\text{MHz}$	-9		30	dB
$P_{AV}$	Precision of the Voltage Gain	$F = 1\text{MHz}$	-1.4		1.4	dB
$A_{Vstep}$	Step Value	$F = 1\text{MHz}$	2.4	3	3.6	dB
$A_{vmis}$	Gain Mismatch between Both Channels	$F = 1\text{MHz}$			1	dB
$B_w$	Bandwidth @ -3dB $R_L = 500\Omega$ , $C_L = 15\text{pF}$	$A_V = -9\text{dB}$	45	100		MHz
		$A_V = +30\text{dB}$	9	17		MHz
$R_{bw}$	Bandwidth Roll-off	$A_V = +30\text{dB}$ , $F = 1\text{MHz}$		0.08		dB
$I_o$	Bandwidth @ -3dB $R_L = 500\Omega$ , $C_L = 15\text{pF}$	[Source] Sink	17 17	28 22		mA
SR	Slew Rate (gain independent)	$V_o = 2\text{Vpeak}$	40	90		V/ $\mu\text{s}$
<b>NOISE AND DISTORTION</b>						
$i_n$	Equivalent Input Noise Current	$F = 100\text{kHz}$		1.6		pA/ $\sqrt{\text{Hz}}$
$e_n$	Equivalent Input Noise Voltage	$F = 100\text{kHz}$ $A_V = 30\text{dB}$		4.7		nV/ $\sqrt{\text{Hz}}$
THD30	Harmonic Distorsion	1Vpeak, $F = 150\text{kHz}$ , $A_V = +30\text{dB}$ , $R_L = 500\Omega$ //15pF				dBc
		H2		-70		
		H3		-93		
		H4		-98		
		H5		-99		
IM3_1	Third Order Intermodulation Product $F1 = 180\text{kHz}$ , $F2 = 280\text{kHz}$	$V_{out} = 1\text{Vpeak}$ , $A_V = +30\text{dB}$ $R_L = 500\Omega$ //15pF				dBc
		@ 80kHz		-77		
		@ 380kHz		-85		
		@640kHz		-86		
		@740kHz		-87		
IM3_2	Third Order Intermodulation Product $F1 = 70\text{kHz}$ , $F2 = 80\text{kHz}$	$V_{out} = 1\text{Vpeak}$ , $A_V = +30\text{dB}$ $R_L = 500\Omega$ //15pF				dBc
		@ 60kHz		-77		
		@ 90kHz		-79		
		@220kHz		-83		
		@230kHz		-84		

**DIGITAL INPUTS**

Pin	Parameter	Min.	Typ.	Max.	Unit
GC1, GC2, GC3 and GC4	Low Level		0	0.8	V
	High Level	2	3.3		
Power Down	Thershold Voltage for Power Down Mode (high level active)		0	0.8	V
		2	3.3		

**SIMPLIFIED SCHEMATIC**

The TS636 consists of two independent channels.

Each channel has two stages. The first is a very low noise digitally controlled variable gain amplifier (range 0 to 18dB).

The TS636 features a high input impedance and a low noise current. To minimize the overall noise figure, the source impedance must be less than 3kΩ.

This value gives an equal contribution of voltage and current noises.

The second stage is a gain/attenuation stage (+12dB to -9dB) featuring a low output impedance.

This output stage can drive loads as low as 500Ω.

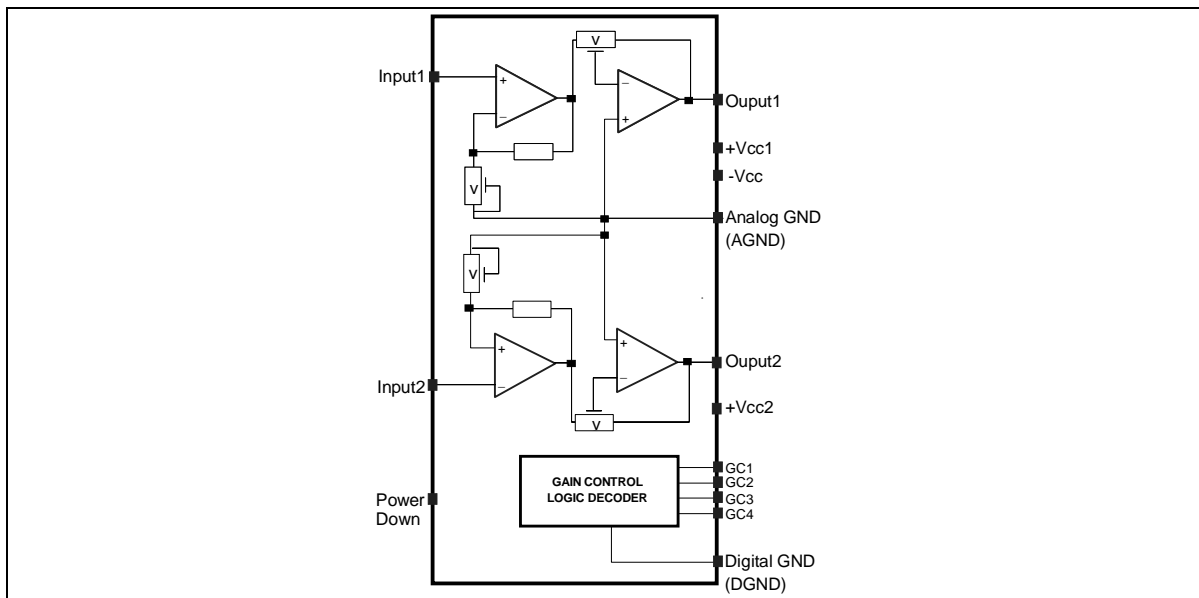

**POWER DOWN MODE POSITION**

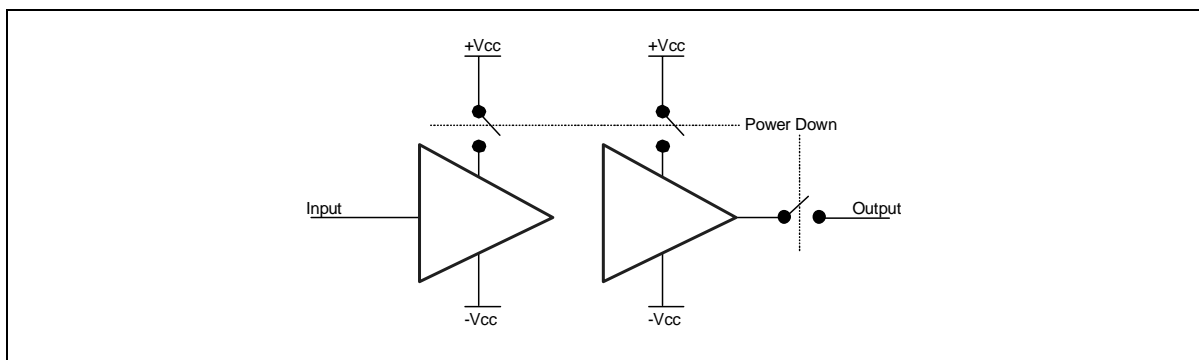

**BANDWIDTH**

The small signal bandwidth is almost constant for gains between +18dB to 0dB and is in the order of 52MHz to 70MHz respectively. For 30dB gain the bandwidth is around 18MHz.

The power bandwidth is typically equal to 30MHz for 2V peak to peak signals.

**MAXIMUM INPUT LEVEL**

The input level must not exceed the following values :

negative peak value: must be greater than  $-V_{CC} + 1.5V$

positive peak value: must be less than  $+V_{CC} - 1.5V$

For example, if a  $\pm 6V$  power supply is used, the input signal can swing between  $-4.5V$  and  $+4.5V$ .

These values are due to common mode input range limitations of the input stage of the first amplifier.

Some other limitations may occur, due to the slew rate of the first operational amplifier (typically in the order of  $300V/\mu s$ ). This means that the maximum input signal decreases at high frequency.

**SINGLE SUPPLY OPERATION**

The incoming signal is AC coupled to the inputs.

The TS636 can be used either with a dual or a single supply. If a single supply is used, the inputs are biased to the mid supply voltage ( $+V_{CC/2}$ ). This bias network must be carefully designed, in order to reject any noise present on the supply rail.

The AGND pin (9) must be connected to  $+V_{CC/2}$ . The bias current of the second stage (inverting structure) is  $8\mu A$  for both amplifiers. A resistor divider structure can be used. Two resistances should be chosen by considering  $8\mu A$  as the 1% of the total current through these resistances. For a single  $+12V$  supply voltage, two resistances of  $7.5k\Omega$  can be used. The differential input consists of a high pass circuit, formed by the  $1\mu F$  capacitor and a  $1k\Omega$  resistance and gives a break frequency of 160Hz.

**SINGLE +12V SUPPLY OF THE TS636**

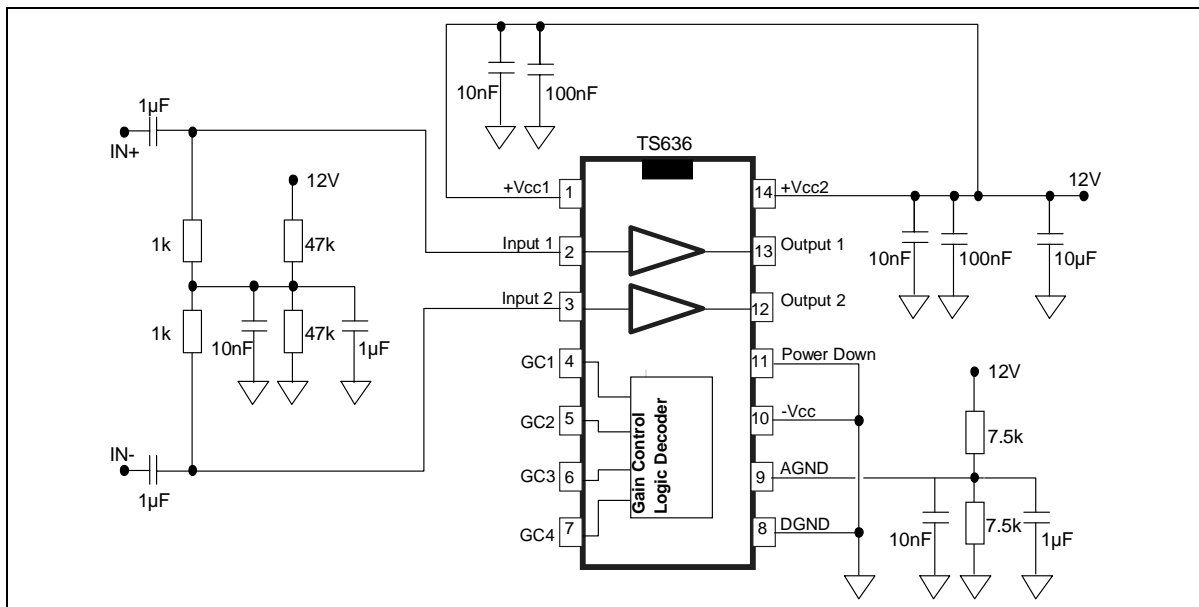

**GAIN CONTROL**

The gain and the power down mode is programmed with a 4 bit digital word :

Digital Control GC4....GC1 MSB LSB	Total Gain (dB)	First Stage Gain (dB)	Second Stage Gain (dB)	Maximum Input Level	Bandwidth Small Signal	Eq. Input Noise (nV/√Hz)
\$0000	-9	0	-9	2.8Vrms	110MHz	29
\$0001	-6	0	-6	2.8Vrms	100MHz	26
\$0010	-3	0	-3	2.8Vrms	85MHz	23
\$0011	0	0	0	2.8Vrms	69MHz	22
\$0100	3	3	0	2Vrms	63MHz	16
\$0101	6	6	0	1.4Vrms	58MHz	12
\$0110	9	9	0	1Vrms	56MHz	9
\$0111	12	12	0	0.7Vrms	55MHz	7
\$1000	15	15	0	0.5Vrms	54MHz	6
\$1001	18	18	0	0.35Vrms	52MHz	4.8
\$1010	21	21	3	0.25Vrms	42MHz	4.7
\$1011	24	24	6	175mVrms	30MHz	4.7
\$1100	27	27	9	125mVrms	24MHz	4.6
\$1101	30	30	12	88mVrms	18MHz	4.6
\$1110	30	30	12	88mVrms	18MHz	4.6
\$1111	30	30	12	88mVrms	18MHz	4.6

The gain is the same for both channels.  
The digital inputs are CMOS compatible. The supply voltage of the logic decoder used to transcode the digital word can be either 3.3V or 5V or V<sub>CC</sub>.

Closed Loop Gain vs. Frequency

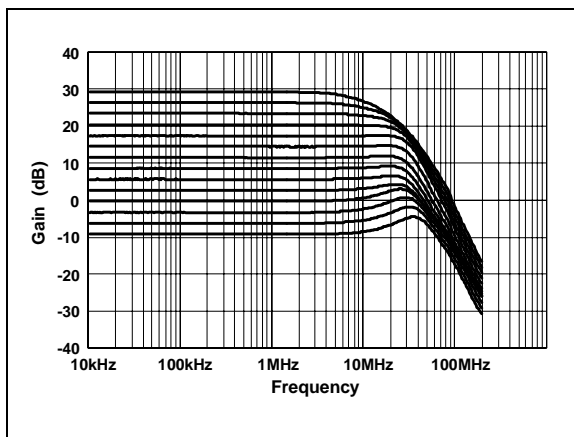

Bandwidth vs. Gain

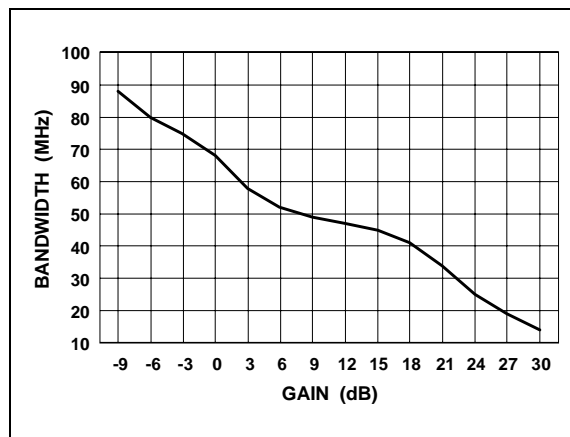

Negative & Positive Slew Rate vs. Gain

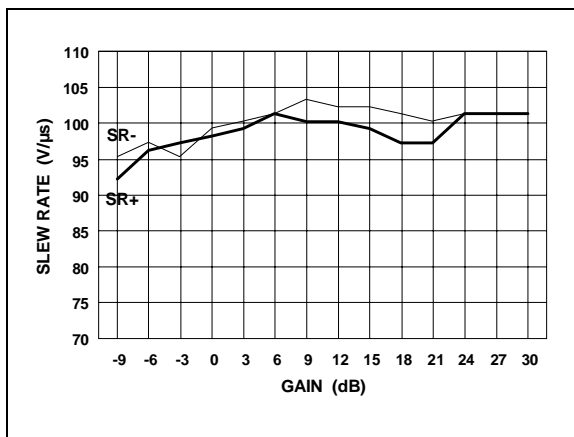

Equivalent Input Voltage Noise vs. Gain

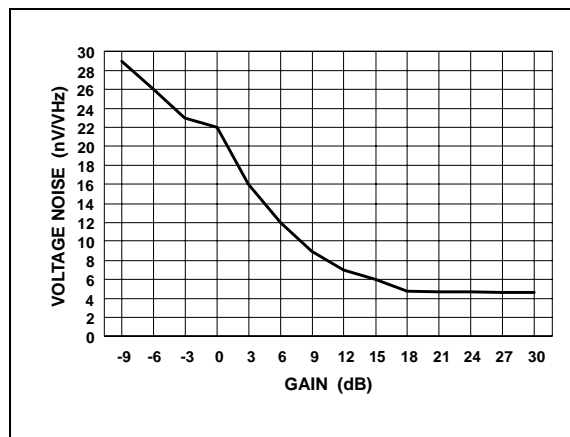

Gain Switching (+15dB to -9dB)

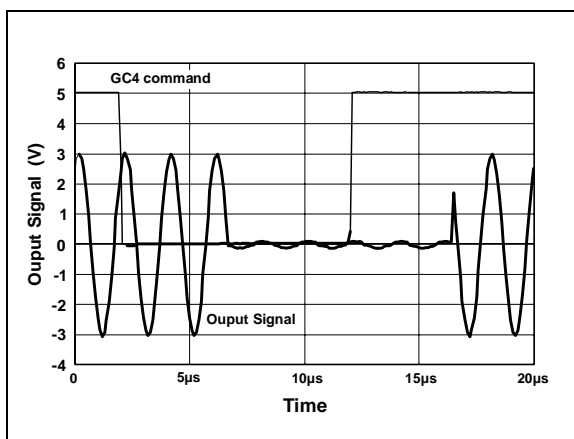

Gain Switching (+30dB to +9dB)

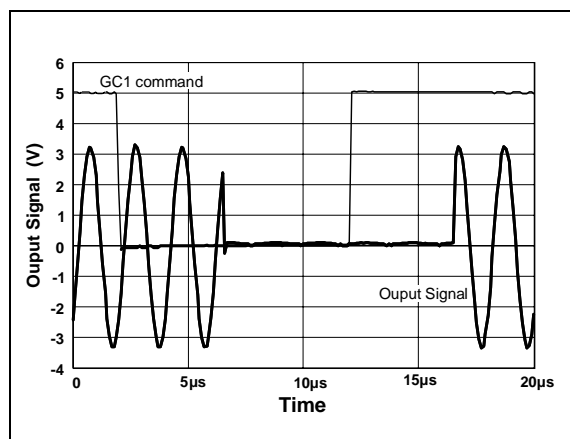

measurement conditions:  $V_{CC} = \pm 6V$ ,  $R_{load} = 500\Omega$ ,  $T_{amb} = 25^\circ C$



**Output/Input Isolation in Power Down Mode vs. Frequency**

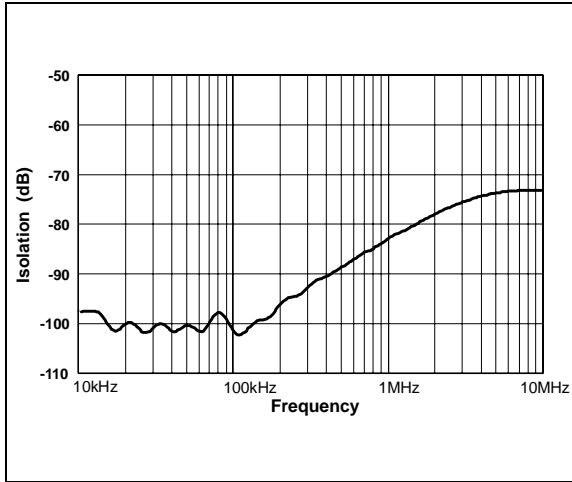

**3rd Order Intermodulation**  
(2 tones : 180kHz and 280kHz)

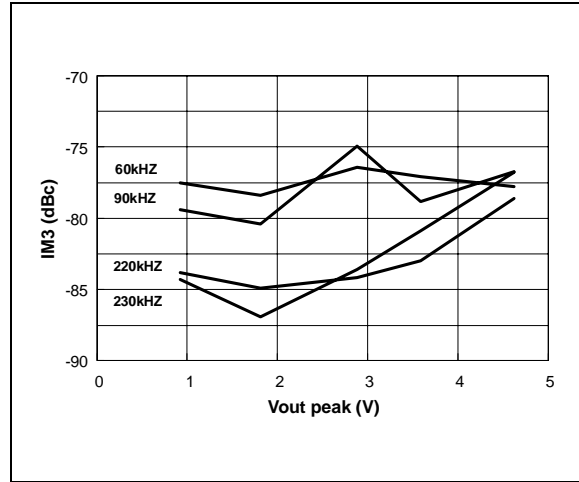

**3rd Order Intermodulation**  
(2 tones : 180kHz and 280kHz)

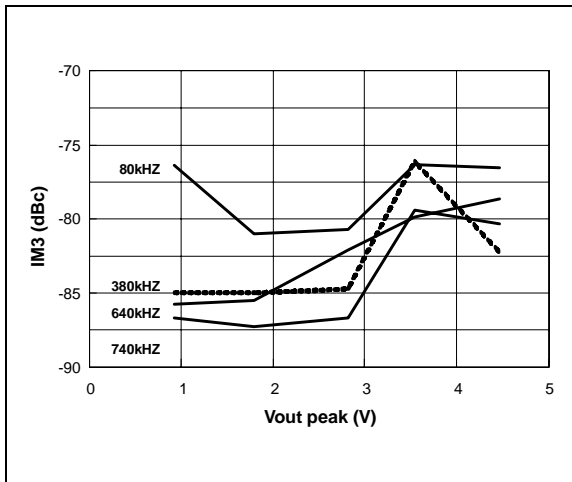

measurement conditions:  $V_{cc}=\pm 6V$ ,  $R_{load}=500\Omega$ ,  $T_{amb}=25^{\circ}C$



**PACKAGE MECHANICAL DATA**  
 14 PINS - PLASTIC MICROPACKAGE (SO)

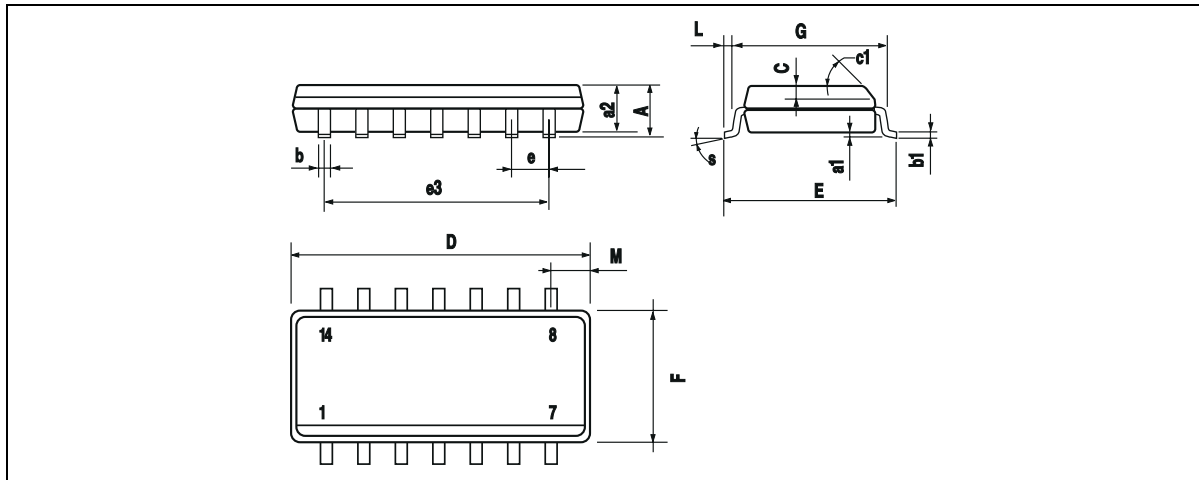

Dim.	Millimeters			Inches		
	Min.	Typ.	Max.	Min.	Typ.	Max.
A			1.75			0.069
a1	0.1		0.2	0.004		0.008
a2			1.6			0.063
b	0.35		0.46	0.014		0.018
b1	0.19		0.25	0.007		0.010
C		0.5			0.020	
c1	45° (typ.)					
D (1)	8.55		8.75	0.336		0.344
E	5.8		6.2	0.228		0.244
e		1.27			0.050	
e3		7.62			0.300	
F (1)	3.8		4.0	0.150		0.157
G	4.6		5.3	0.181		0.208
L	0.5		1.27	0.020		0.050
M			0.68			0.027
S	8° (max.)					

Note : (1) D and F do not include mold flash or protrusions - Mold flash or protrusions shall not exceed 0.15mm (.066 inc) ONLY FOR DATA BOOK.

Information furnished is believed to be accurate and reliable. However, STMicroelectronics assumes no responsibility for the consequences of use of such information nor for any infringement of patents or other rights of third parties which may result from its use. No license is granted by implication or otherwise under any patent or patent rights of STMicroelectronics. Specifications mentioned in this publication are subject to change without notice. This publication supersedes and replaces all information previously supplied. STMicroelectronics products are not authorized for use as critical components in life support devices or systems without express written approval of STMicroelectronics.

© The ST logo is a registered trademark of STMicroelectronics

© 2001 STMicroelectronics - Printed in Italy - All Rights Reserved  
 STMicroelectronics GROUP OF COMPANIES

Australia - Brazil - China - Finland - France - Germany - Hong Kong - India - Italy - Japan - Malaysia - Malta - Morocco  
 Singapore - Spain - Sweden - Switzerland - United Kingdom

© <http://www.st.com>