

## DUAL BUS BUFFER (3-STATE)

- HIGH SPEED:  $t_{PD} = 3.8ns$  (TYP.) at  $V_{CC} = 5V$
- LOW POWER DISSIPATION:  
 $I_{CC} = 1\mu A$ (MAX.) at  $T_A = 25^\circ C$
- HIGH NOISE IMMUNITY:  
 $V_{NIH} = V_{NIL} = 28\% V_{CC}$  (MIN.)
- POWER DOWN PROTECTION ON INPUTS AND OUTPUTS
- SYMMETRICAL OUTPUT IMPEDANCE:  
 $|I_{OH}| = I_{OL} = 8mA$  (MIN) at  $V_{CC} = 4.5V$
- BALANCED PROPAGATION DELAYS:  
 $t_{PLH} \cong t_{PHL}$
- OPERATING VOLTAGE RANGE:  
 $V_{CC}(OPR) = 2V$  to  $5.5V$
- IMPROVED LATCH-UP IMMUNITY

### DESCRIPTION

The 74V2G125 is an advanced high-speed CMOS DUAL BUS BUFFER fabricated with sub-micron silicon gate and double-layer metal wiring C<sup>2</sup>MOS technology.

3-STATE control input  $\overline{nG}$  has to be set HIGH to place the output into the high impedance state.

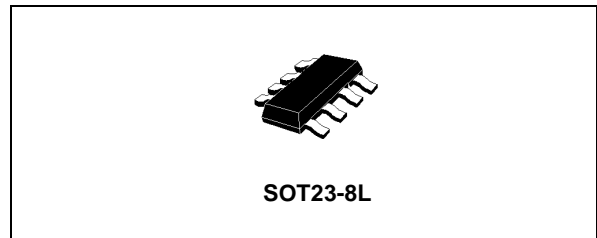

### ORDER CODES

PACKAGE	T & R
SOT23-8L	74V2G125STR

Power down protection is provided on all inputs and outputs and 0 to 7V can be accepted on inputs with no regard to the supply voltage.

This device can be used to interface 5V to 3V systems and it is ideal for portable applications like personal digital assistant, camcorder and all battery-powered equipment.

All inputs and outputs are equipped with protection circuits against static discharge, giving them ESD immunity and transient excess voltage.

### PIN CONNECTION AND IEC LOGIC SYMBOLS

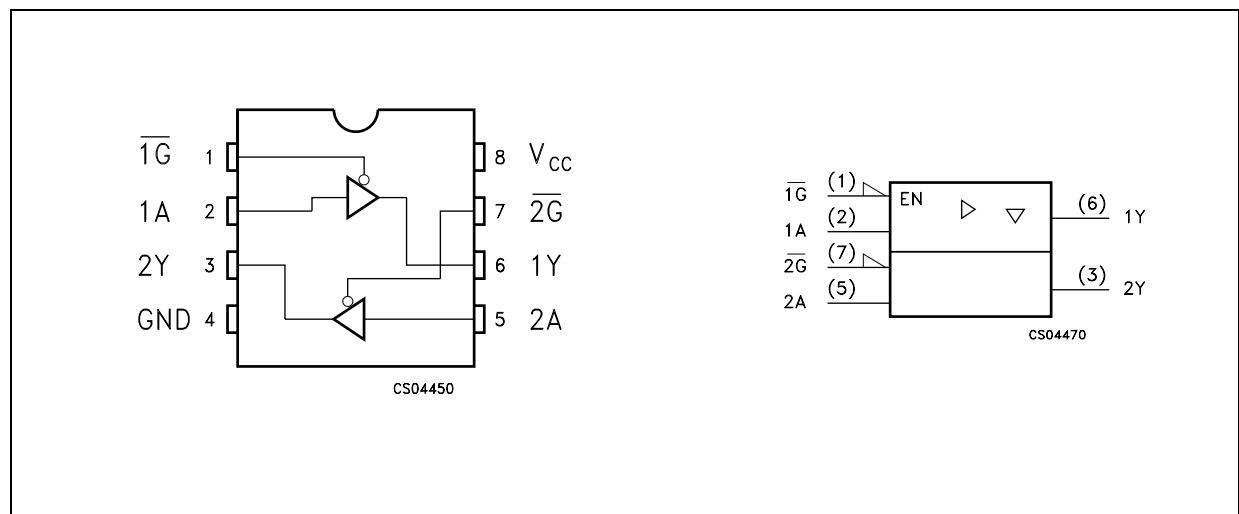

## INPUT EQUIVALENT CIRCUIT

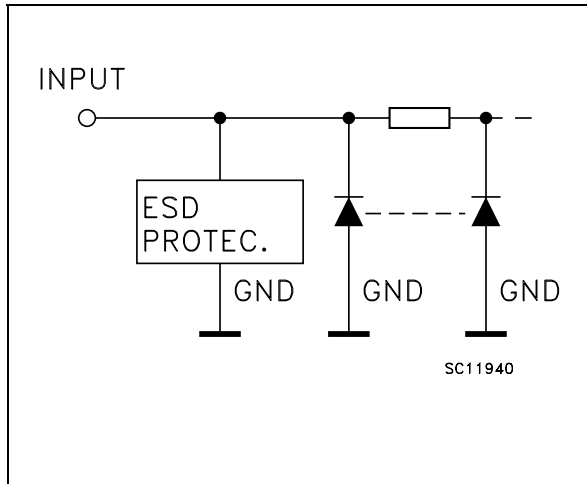

## PIN DESCRIPTION

PIN No	SYMBOL	NAME AND FUNCTION
1, 7	$\overline{1G}, \overline{2G}$	Output Enable Inputs
2, 5	1A, 2A	Data Inputs
3, 6	2Y, 1Y	Data Outputs
4	GND	Ground (0V)
8	$V_{CC}$	Positive Supply Voltage

## TRUTH TABLE

A	$\overline{G}$	Y
X	H	Z
L	L	L
H	L	H

X: "H" or "L"  
Z: High Impedance

## ABSOLUTE MAXIMUM RATINGS

Symbol	Parameter	Value	Unit
$V_{CC}$	Supply Voltage	-0.5 to +7.0	V
$V_I$	DC Input Voltage	-0.5 to +7.0	V
$V_O$	DC Output Voltage (see note 1)	-0.5 to +7.0	V
$V_O$	DC Output Voltage (see note 2)	-0.5 to $V_{CC} + 0.5$	V
$I_{IK}$	DC Input Diode Current	- 20	mA
$I_{OK}$	DC Output Diode Current	- 20	mA
$I_O$	DC Output Current	$\pm 25$	mA
$I_{CC}$ or $I_{GND}$	DC $V_{CC}$ or Ground Current	$\pm 50$	mA
$T_{stg}$	Storage Temperature	-65 to +150	$^{\circ}C$
$T_L$	Lead Temperature (10 sec)	260	$^{\circ}C$

Absolute Maximum Ratings are those values beyond which damage to the device may occur. Functional operation under these conditions is not implied.

1)  $V_{CC}=0V$  or  $\overline{nG}=V_{CC}$  (Output in High Impedance state)

2) High or Low State

## RECOMMENDED OPERATING CONDITIONS

Symbol	Parameter	Value	Unit
$V_{CC}$	Supply Voltage	2 to 5.5	V
$V_I$	Input Voltage	0 to 5.5	V
$V_O$	Output Voltage (see note 1)	0 to 5.5	V
$V_O$	Output Voltage (see note 2)	0 to $V_{CC}$	V
$T_{op}$	Operating Temperature	-55 to 125	$^{\circ}C$
dt/dv	Input Rise and Fall Time (note 3) ( $V_{CC} = 3.3 \pm 0.3V$ ) ( $V_{CC} = 5.0 \pm 0.5V$ )	0 to 100 0 to 20	ns/V ns/V

1)  $V_{CC}=0V$  or  $\overline{nG}=V_{CC}$  (Output in High Impedance state)

2) High or Low State

3)  $V_{IN}$  from 30% to 70% of  $V_{CC}$

## DC SPECIFICATION

Symbol	Parameter	Test Condition		Value						Unit	
		V <sub>CC</sub> (V)		T <sub>A</sub> = 25°C			-40 to 85°C		-55 to 125°C		
				Min.	Typ.	Max.	Min.	Max.	Min.		Max.
V <sub>IH</sub>	High Level Input Voltage	2.0		1.5			1.5		1.5		V
		3.0 to 5.5		0.7V <sub>CC</sub>			0.7V <sub>CC</sub>		0.7V <sub>CC</sub>		
V <sub>IL</sub>	Low Level Input Voltage	2.0				0.5		0.5		0.5	V
		3.0 to 5.5				0.3V <sub>CC</sub>		0.3V <sub>CC</sub>		0.3V <sub>CC</sub>	
V <sub>OH</sub>	High Level Output Voltage	2.0	I <sub>O</sub> =-50 μA	1.9	2.0		1.9		1.9		V
		3.0	I <sub>O</sub> =-50 μA	2.9	3.0		2.9		2.9		
		4.5	I <sub>O</sub> =-50 μA	4.4	4.5		4.4		4.4		
		3.0	I <sub>O</sub> =-4 mA	2.58			2.48		2.4		
		4.5	I <sub>O</sub> =-8 mA	3.94			3.8		3.7		
V <sub>OL</sub>	Low Level Output Voltage	2.0	I <sub>O</sub> =50 μA		0.0	0.1		0.1		0.1	V
		3.0	I <sub>O</sub> =50 μA		0.0	0.1		0.1		0.1	
		4.5	I <sub>O</sub> =50 μA		0.0	0.1		0.1		0.1	
		3.0	I <sub>O</sub> =4 mA			0.36		0.44		0.55	
		4.5	I <sub>O</sub> =8 mA			0.36		0.44		0.55	
I <sub>OZ</sub>	High Impedance Output Leakage Current	5.5	V <sub>I</sub> = V <sub>IH</sub> or V <sub>IL</sub> V <sub>O</sub> = 5.5 or GND			±0.25		± 2.5		± 5	μA
I <sub>I</sub>	Input Leakage Current	0 to 5.5	V <sub>I</sub> = 5.5V or GND			± 0.1		± 1		± 1	μA
I <sub>CC</sub>	Quiescent Supply Current	5.5	V <sub>I</sub> = V <sub>CC</sub> or GND			1		10		20	μA
I <sub>OPD</sub>	Power down Output Leakage Current	0	V <sub>O</sub> = 5.5			0.5		5		10	μA

AC ELECTRICAL CHARACTERISTICS (Input  $t_r = t_f = 3\text{ns}$ )

Symbol	Parameter	Test Condition			Value						Unit	
		$V_{CC}$ (V)	$C_L$ (pF)		$T_A = 25^\circ\text{C}$			$-40$ to $85^\circ\text{C}$		$-55$ to $125^\circ\text{C}$		
					Min.	Typ.	Max.	Min.	Max.	Min.		Max.
$t_{PLH}$ $t_{PHL}$	Propagation Delay Time	3.3(*)	15			5.1	7.5	1.0	8.5	1.0	9.5	ns
		3.3(**)	50			5.6	8.0	1.0	9.5	1.0	10.5	
		5.0(**)	15			3.8	5.5	1.0	6.5	1.0	7.5	
		5.0(**)	50			4.3	6.5	1.0	7.5	1.0	8.5	
$t_{PLZ}$ $t_{PHZ}$	Output Disable Time	3.3(*)	15	$R_L = 1\text{K}\Omega$		5.4	8.0	1.0	9.0	1.0	10.0	ns
		3.3(**)	50	$R_L = 1\text{K}\Omega$		7.9	11.5	1.0	12.5	1.0	13.5	
		5.0(**)	15	$R_L = 1\text{K}\Omega$		3.6	5.0	1.0	6.0	1.0	7.0	
		5.0(**)	50	$R_L = 1\text{K}\Omega$		5.1	7.0	1.0	8.0	1.0	9.0	
$t_{PZL}$ $t_{PZH}$	Output Enable Time	3.3(*)	15	$R_L = 1\text{K}\Omega$		5.4	7.6	1.0	9.5	1.0	10.5	ns
		3.3(**)	50	$R_L = 1\text{K}\Omega$		5.9	8.5	1.0	10.0	1.0	11.0	
		5.0(**)	15	$R_L = 1\text{K}\Omega$		3.7	5.9	1.0	7.0	1.0	8.0	
		5.0(**)	50	$R_L = 1\text{K}\Omega$		4.1	6.5	1.0	7.5	1.0	8.5	

(\*) Voltage range is  $3.3\text{V} \pm 0.3\text{V}$ (\*\*) Voltage range is  $5.0\text{V} \pm 0.5\text{V}$ 

## CAPACITIVE CHARACTERISTICS

Symbol	Parameter	Test Condition			Value						Unit	
					$T_A = 25^\circ\text{C}$			$-40$ to $85^\circ\text{C}$		$-55$ to $125^\circ\text{C}$		
					Min.	Typ.	Max.	Min.	Max.	Min.		Max.
$C_{IN}$	Input Capacitance					4	10		10		10	pF
$C_{OUT}$	Output Capacitance					6						pF
$C_{PD}$	Power Dissipation Capacitance (note 1)					14						pF

1)  $C_{PD}$  is defined as the value of the IC's internal equivalent capacitance which is calculated from the operating current consumption without load. (Refer to Test Circuit). Average current can be obtained by the following equation.  $I_{CC(opr)} = C_{PD} \times V_{CC} \times f_{IN} + I_{CC}/2$

TEST CIRCUIT TEST CIRCUIT

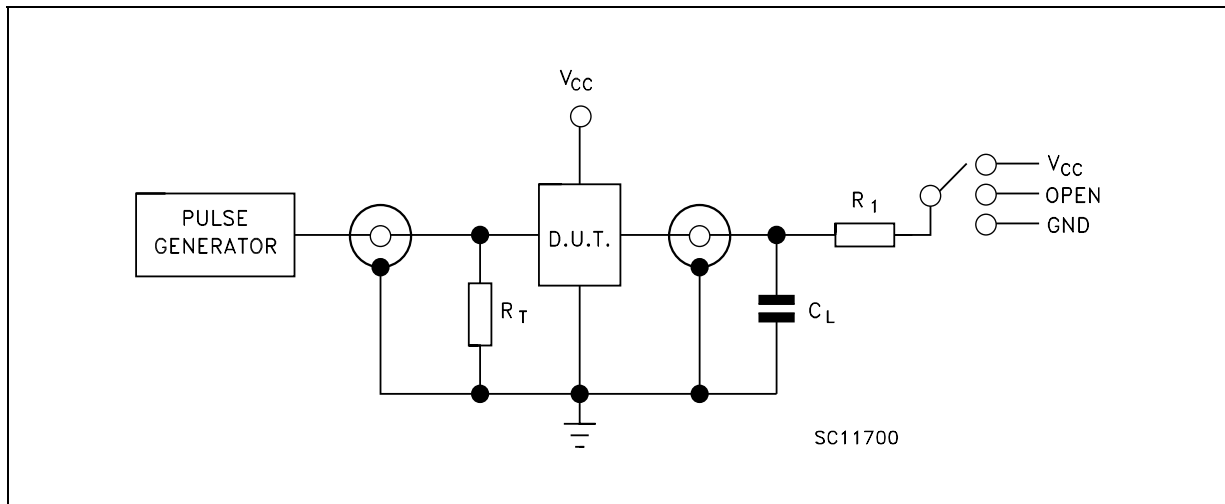

TEST	SWITCH
$t_{PLH}$ , $t_{PHL}$	Open
$t_{PZL}$ , $t_{PLZ}$	$V_{CC}$
$t_{PZH}$ , $t_{PHZ}$	GND

$C_L = 15/50\text{pF}$  or equivalent (includes jig and probe capacitance)  
 $R_1 = 1\text{K}\Omega$  or equivalent  
 $R_T = Z_{OUT}$  of pulse generator (typically  $50\Omega$ )

WAVEFORM 1 : PROPAGATION DELAYS (f=1MHz; 50% duty cycle)

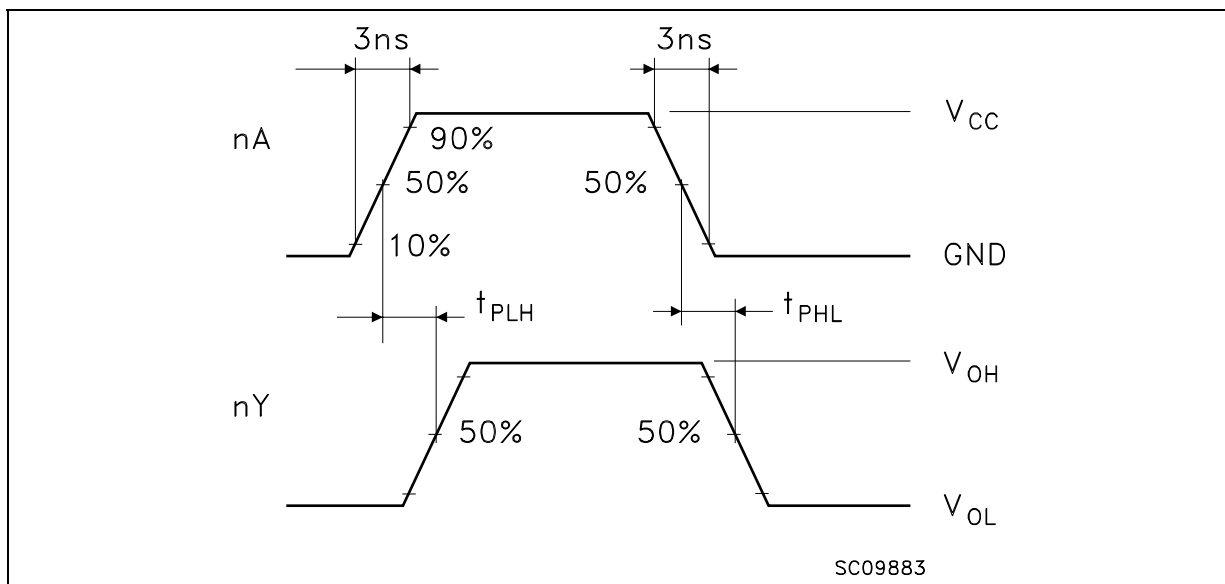

WAVEFORM 2: OUTPUT ENABLE AND DISABLE TIME (f=1MHz; 50% duty cycle)

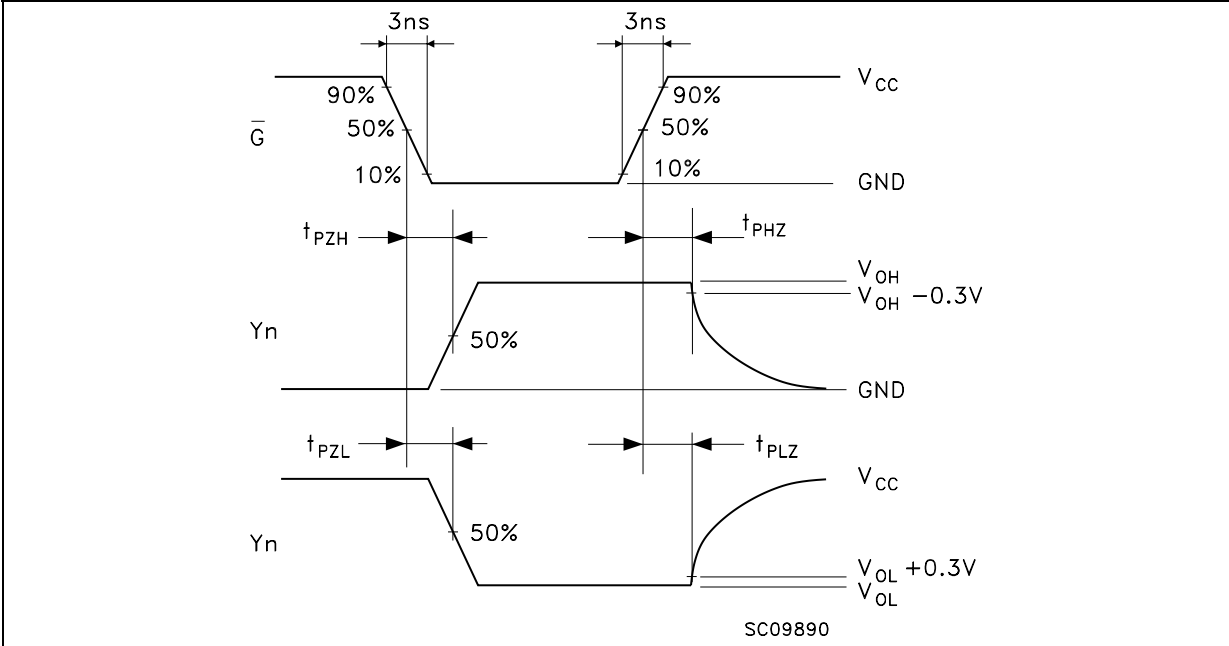

## SOT23-8L MECHANICAL DATA

DIM.	mm.			mils		
	MIN.	TYP	MAX.	MIN.	TYP.	MAX.
A	0.90		1.45	35.4		57.1
A1	0.00		0.15	0.0		5.9
A2	0.90		1.30	35.4		51.2
b	0.22		0.38	8.6		14.9
C	0.09		0.20	3.5		7.8
D	2.80		3.00	110.2		118.1
E	2.60		3.00	102.3		118.1
E1	1.50		1.75	59.0		68.8
e	0	.65			25.6	
e1		1.95			76.7	
L	0.35		0.55	13.7		21.6

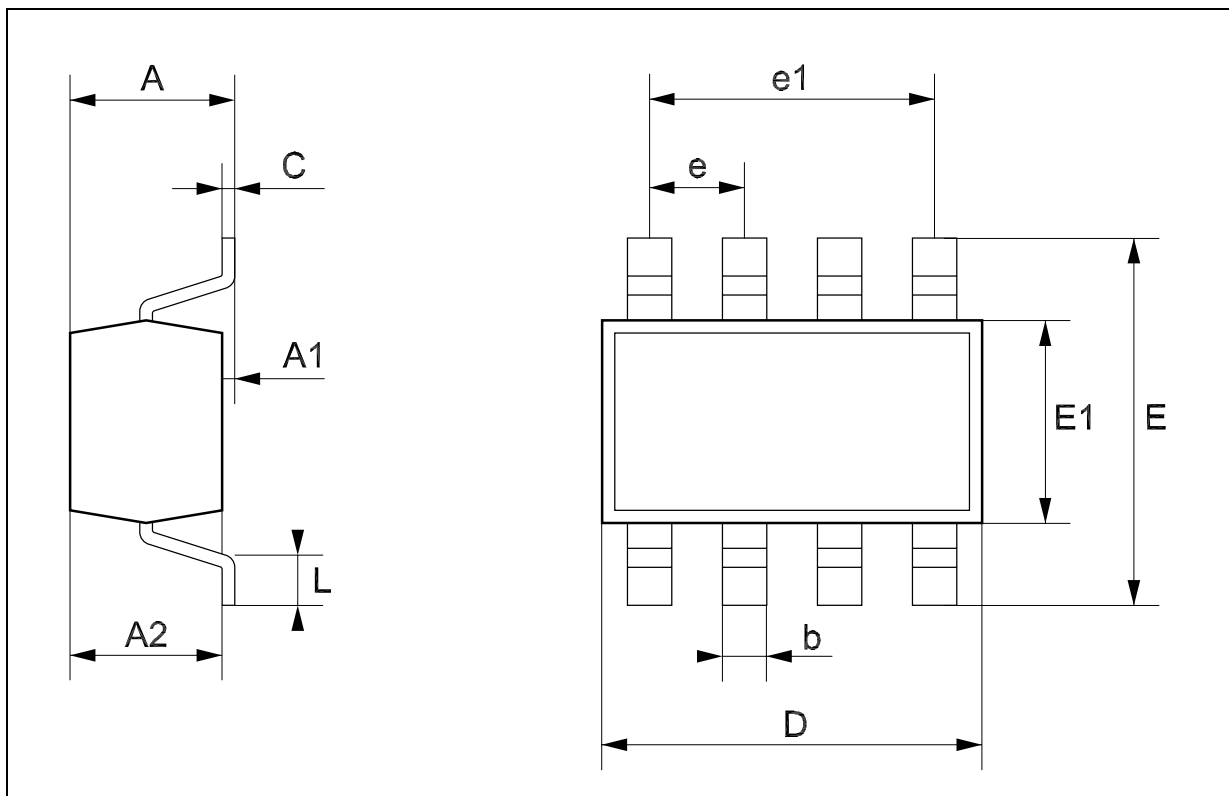

## Tape &amp; Reel SOT23-xL MECHANICAL DATA

DIM.	mm.			inch		
	MIN.	TYP	MAX.	MIN.	TYP.	MAX.
A			180			7.086
C	12.8	13.0	13.2	0.504	0.512	0.519
D	20.2			0.795		
N	60			2.362		
T			14.4			0.567
Ao	3.13	3.23	3.33	0.123	0.127	0.131
Bo	3.07	3.17	3.27	0.120	0.124	0.128
Ko	1.27	1.37	1.47	0.050	0.054	0.058
Po	3.9	4.0	4.1	0.153	0.157	0.161
P	3.9	4.0	4.1	0.153	0.157	0.161

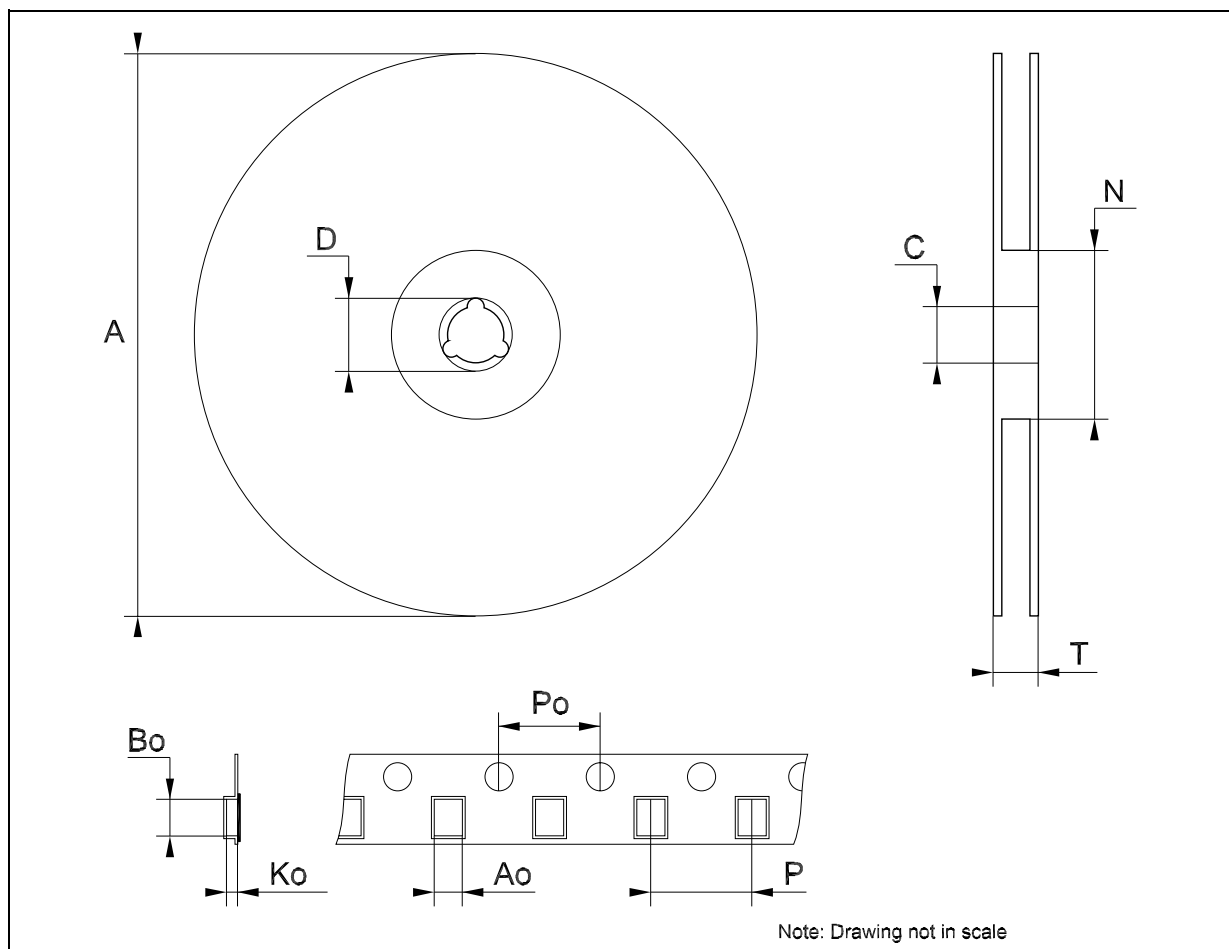



Information furnished is believed to be accurate and reliable. However, STMicroelectronics assumes no responsibility for the consequences of use of such information nor for any infringement of patents or other rights of third parties which may result from its use. No license is granted by implication or otherwise under any patent or patent rights of STMicroelectronics. Specifications mentioned in this publication are subject to change without notice. This publication supersedes and replaces all information previously supplied. STMicroelectronics products are not authorized for use as critical components in life support devices or systems without express written approval of STMicroelectronics.

© The ST logo is a registered trademark of STMicroelectronics

© 2003 STMicroelectronics - Printed in Italy - All Rights Reserved  
STMicroelectronics GROUP OF COMPANIES

Australia - Brazil - Canada - China - Finland - France - Germany - Hong Kong - India - Israel - Italy - Japan - Malaysia - Malta - Morocco  
Singapore - Spain - Sweden - Switzerland - United Kingdom - United States.

© <http://www.st.com>

