

DUAL BILATERAL SWITCH

- HIGH SPEED:
 $t_{PD} = 0.3ns$ (TYP.) at $V_{CC} = 5V$
 $t_{PD} = 0.4ns$ (TYP.) at $V_{CC} = 3.3V$
- LOW POWER DISSIPATION:
 $I_{CC} = 1\mu A$ (MAX.) at $T_A = 25^\circ C$
- LOW "ON" RESISTANCE:
 $R_{ON} = 6.5\Omega$ (TYP.) AT $V_{CC} = 5V I_{I/O} = 1mA$
 $R_{ON} = 8.5\Omega$ (TYP.) AT $V_{CC} = 3.3V I_{I/O} = 1mA$
- SINE WAVE DISTORTION:
0.04% AT $V_{CC} = 3.3V f = 1KHz$
- WIDE OPERATING RANGE:
 V_{CC} (OPR) = 2V TO 5.5V
- IMPROVED LATCH-UP IMMUNITY

DESCRIPTION

The 74V2G66 is an advanced high-speed CMOS DUAL BILATERAL SWITCH fabricated in silicon gate C²MOS technology. It achieves high speed propagation delay and VERY LOW ON resistances while maintaining true CMOS low power consumption. This bilateral switch handles rail to rail analog and digital signals that may vary across the full power supply range (from GND to V_{CC}).

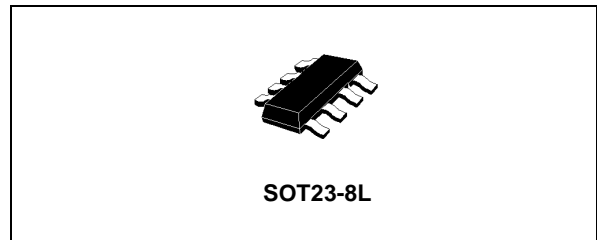

ORDER CODES

PACKAGE	T & R
SOT23-8L	74V2G66STR

The C input is provided to control the switch and it's compatible with standard CMOS output; the switch is ON (port I/O is connected to Port O/I) when the C input is held high and OFF (high impedance state exists between the two ports) when C is held low. It can be used in many application as Battery Powered System, Test Equipment. It's available in the commercial and extended temperature range in SOT23-8L package. All inputs and output are equipped with protection circuits against static discharge, giving them ESD immunity and transient excess voltage.

PIN CONNECTION AND IEC LOGIC SYMBOLS

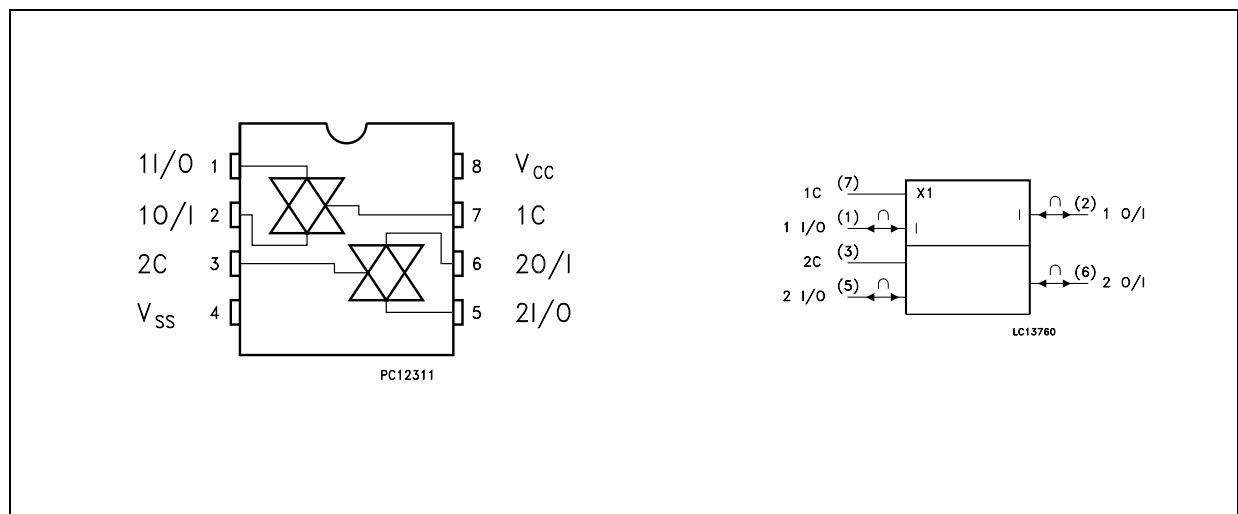

INPUT EQUIVALENT CIRCUIT

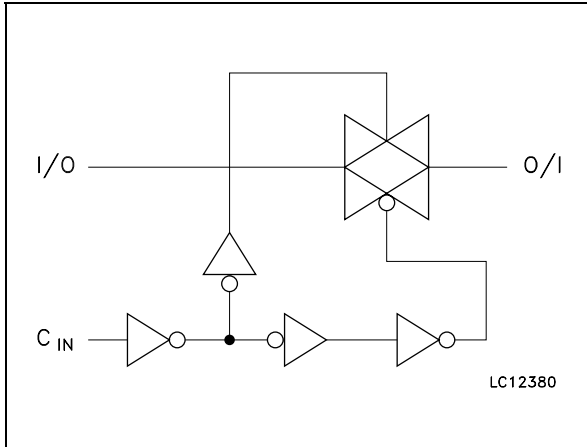

PIN DESCRIPTION

PIN No	SYMBOL	NAME AND FUNCTION
1, 5	1I/O, 2I/O	Independent Input/Output
2, 6	1O/I, 2O/I	Independent Output/Input
7, 3	1C, 2C	Enable Input (Active HIGH)
4	GND	Ground (0V)
8	V _{CC}	Positive Supply Voltage

TRUTH TABLE

CONTROL	SWITCH FUNCTION
H	ON
L	OFF *

* : High Impedance State

ABSOLUTE MAXIMUM RATINGS

Symbol	Parameter	Value	Unit
V _{CC}	Supply Voltage	-0.5 to +7.0	V
V _I	DC Input Voltage	-0.5 to V _{CC} + 0.5	V
V _{IC}	DC Control Input Voltage	-0.5 to +7.0	V
V _O	DC Output Voltage	-0.5 to V _{CC} + 0.5	V
I _{IK}	DC Input Diode Current	± 20	mA
I _{IK}	DC Control Input Diode Current	- 20	mA
I _{OK}	DC Output Diode Current	± 20	mA
I _O	DC Output Current	± 50	mA
I _{CC} or I _{GND}	DC V _{CC} or Ground Current	± 50	mA
T _{stg}	Storage Temperature	-65 to +150	°C
T _L	Lead Temperature (10 sec)	300	°C

Absolute Maximum Ratings are those values beyond which damage to the device may occur. Functional operation under these conditions is not implied

RECOMMENDED OPERATING CONDITIONS

Symbol	Parameter	Value	Unit
V _{CC}	Supply Voltage	2 to 5.5	V
V _I	Input Voltage	0 to V _{CC}	V
V _{IC}	Control Input Voltage	0 to 5.5	V
V _O	Output Voltage	0 to V _{CC}	V
T _{op}	Operating Temperature	-55 to 125	°C
dt/dv	Input Rise and Fall Time (note 1) V _{CC} = 5.0V	0 to 20	ns/V

1) V_{IN} from 30% to 70% of V_{CC} on control pin

DC SPECIFICATIONS

Symbol	Parameter	Test Condition		Value						Unit	
		V _{CC} (V)		T _A = 25°C			-40 to 85°C		-55 to 125°C		
				Min.	Typ.	Max.	Min.	Max.	Min.		Max.
V _{IH}	High Level Input Voltage	2.0		1.5			1.5		1.5		V
		2.7 to 5.5		0.7V _{CC}			0.7V _{CC}		0.7V _{CC}		
V _{IL}	Low Level Input Voltage	2.0				0.5		0.5		0.5	V
		2.7 to 5.5				0.3V _{CC}		0.3V _{CC}		0.3V _{CC}	
R _{ON}	ON Resistance	3.3 ^(*)	V _{IC} = V _{IH}		12.5	19		23		27	Ω
		5.0 ^(**)	V _{I/O} = V _{CC} to GND I _{I/O} ≤ 1mA		7.5	10		12		14	
R _{ON}	ON Resistance	3.3 ^(*)	V _{IC} = V _{IH}		8.5	10.5		12.5		15	Ω
		5.0 ^(**)	V _{I/O} = V _{CC} or GND I _{I/O} ≤ 1mA		6.5	8.5		10		12	
I _{OFF}	Input/Output Leakage Current (SWITCH OFF)	5.5	V _{OS} = V _{CC} to GND V _{IS} = V _{CC} to GND V _{IC} = V _{IL}			±0.1		± 1		± 5	μA
I _{IZ}	Switch Input Leakage Current (SWITCH ON, OUTPUT OPEN)	5.5	V _{OS} = V _{CC} to GND V _{IC} = V _{IH}			±0.1		± 1		± 5	μA
I _{IN}	Control Input Leakage Current	0 to 5.5	V _{IC} = 5.5V or GND			± 0.1		± 1.0		± 1.0	μA
I _{CC}	Quiescent Supply Current	5.5	V _I = V _{CC} or GND			1		10		20	μA

(*) Voltage range is 3.3V ± 0.3V

(**) Voltage range is 5V ± 0.5V

AC ELECTRICAL CHARACTERISTICS (C_L = 50pF, Input t_r = t_f = 3ns)

Symbol	Parameter	Test Condition		Value						Unit	
		V _{CC} (V)		T _A = 25°C			-40 to 85°C		-55 to 125°C		
				Min.	Typ.	Max.	Min.	Max.	Min.		Max.
t _{PD}	Delay Time	3.3 ^(*)	t _r = t _f = 6ns		0.4	0.8		1.2		2.4	ns
		5.0 ^(**)			0.3	0.6		1.0		2.0	
t _{PLZ} t _{PHZ}	Output Disable Time	3.3 ^(*)	R _L = 500 Ω		5.0	7.5		9.0		10.0	ns
		5.0 ^(**)			5.0	7.5		9.0		10.0	
t _{PZL} t _{PZH}	Output Enable Time	3.3 ^(*)	R _L = 1 KΩ		2.5	4.0		5.0		7.0	ns
		5.0 ^(**)			2.0	4.0		5.0		7.0	

(*) Voltage range is 3.3V ± 0.3V

(**) Voltage range is 5.0V ± 0.5V

CAPACITIVE CHARACTERISTICS

Symbol	Parameter	Test Condition		Value						Unit	
		V _{CC} (V)		T _A = 25°C			-40 to 85°C		-55 to 125°C		
				Min.	Typ.	Max.	Min.	Max.	Min.		Max.
C _{IN}	Input Capacitance				3	10		10		10	pF
C _{I/O}	Output Capacitance				10						
C _{PD}	Power Dissipation Capacitance (note 1)	3.3			2.5						pF
		5.0			3						

1) C_{PD} is defined as the value of the IC's internal equivalent capacitance which is calculated from the operating current consumption without load. (Refer to Test Circuit). Average operating current can be obtained by the following equation. $I_{CC(opr)} = C_{PD} \times V_{CC} \times f_{IN} + I_{CC}/4$

ANALOG SWITCH CHARACTERISTICS (GND = 0V; T_A = 25°C)

Symbol	Parameter	Test Condition			Value	Unit
		V _{CC} (V)	V _{IN} (V _{p-p})		Typ.	
	Sine Wave Distortion (THD)	3.3(*)	2.75	f _{IN} = 1 KHz R _L = 10 KΩ, C _L = 50 pF	0.04	%
		5.0(**)	4		0.04	
f _{MAX}	Frequency Response (Switch ON)	3.3(*)	Adjust f _{IN} voltage to obtain 0 dBm at V _{OS} . Increase f _{IN} Frequency until dB meter reads -3dB R _L = 50Ω, C _L = 10 pF		150	MHz
		5.0(**)			180	
	Feed through Attenuation (Switch OFF)	3.3(*)	V _{IN} is centered at V _{CC} /2 Adjust f _{IN} Voltage to obtained 0dBm at V _{IS} R _L = 600Ω, C _L = 50 pF, f _{IN} = 1KHz sine wave		-60	dB
		5.0(**)			-60	
	Crosstalk (Control Input to Signal Output)	3.3(*)	R _L = 600Ω, C _L = 50 pF, f _{IN} = 1KHz square wave t _r = t _f = 6ns		60	mV
		5.0(**)			60	

(*) Voltage range is 3.3V ± 0.3V

(**) Voltage range is 5.0V ± 0.5V

SWITCHING CHARACTERISTIC TEST CIRCUIT

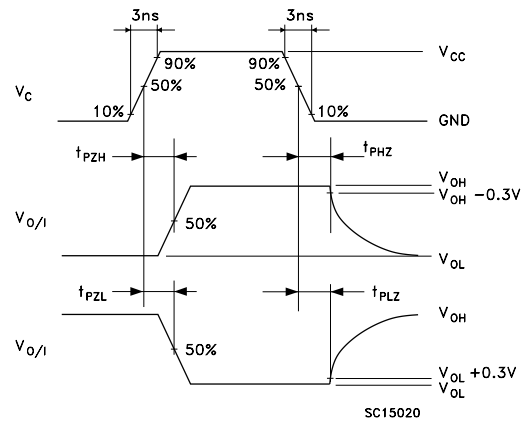
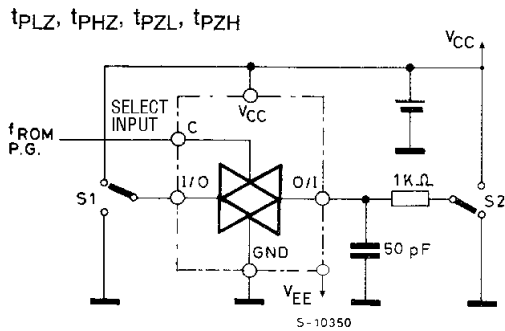

FEEDTHROUGH ATTENUATION

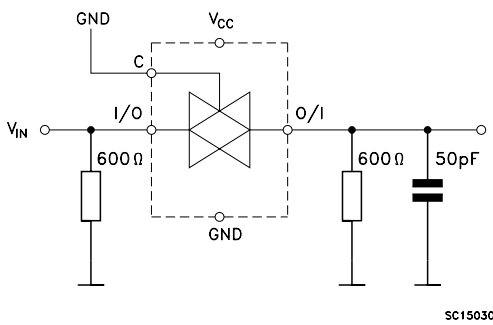

BANDWIDTH ATTENUATION

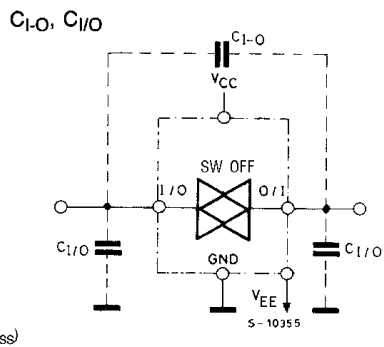
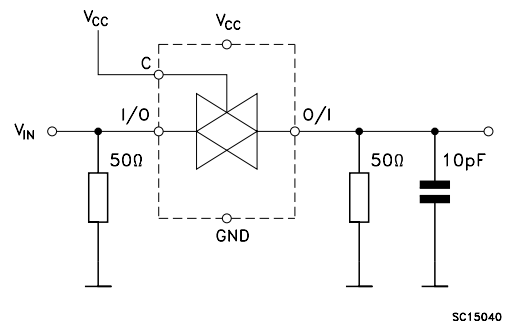

MAXIMUM CONTROL FREQUENCY

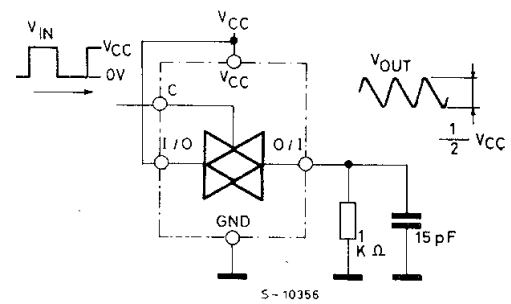

CROSSTALK (control to output)

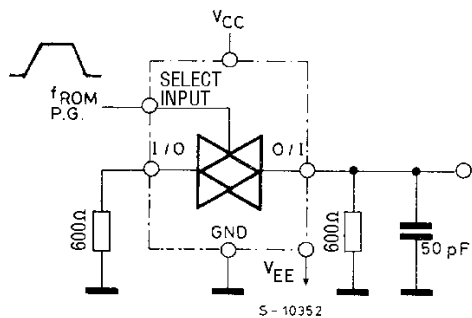

CHANNEL RESISTANCE (R_{ON})

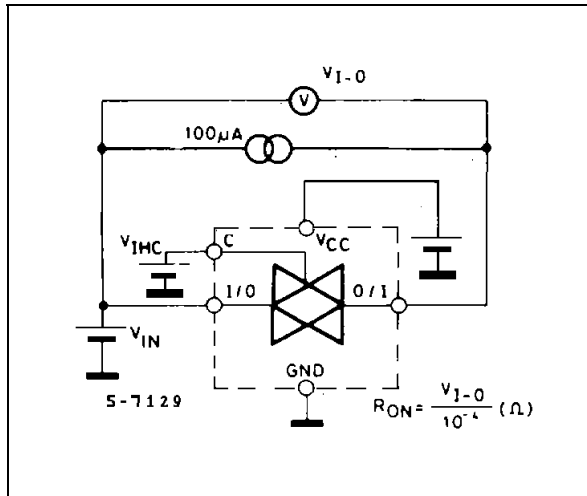

I_{CC} (Opr.)

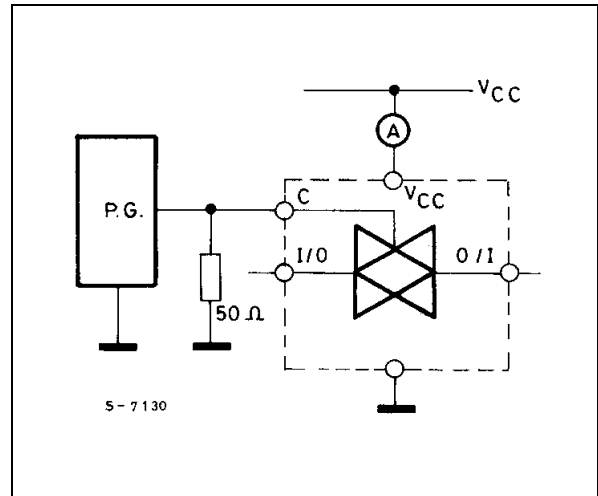

SOT23-8L MECHANICAL DATA						
---------------------------------	--	--	--	--	--	--

DIM.	mm.			mils		
	MIN.	TYP	MAX.	MIN.	TYP.	MAX.
A	0.90		1.45	35.4		57.1
A1	0.00		0.15	0.0		5.9
A2	0.90		1.30	35.4		51.2
b	0.22		0.38	8.6		14.9
C	0.09		0.20	3.5		7.8
D	2.80		3.00	110.2		118.1
E	2.60		3.00	102.3		118.1
E1	1.50		1.75	59.0		68.8
e	0	.65			25.6	
e1		1.95			76.7	
L	0.35		0.55	13.7		21.6

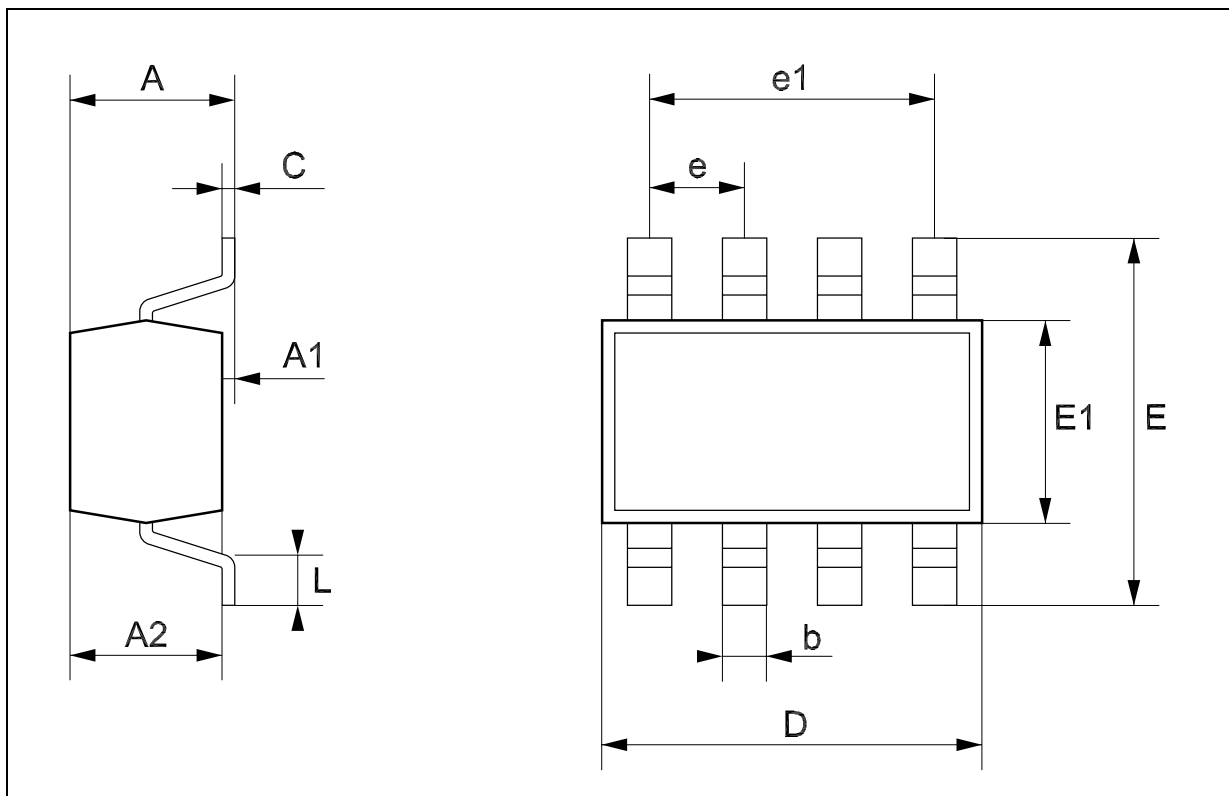

Tape & Reel SOT23-xL MECHANICAL DATA

DIM.	mm.			inch		
	MIN.	TYP	MAX.	MIN.	TYP.	MAX.
A			180			7.086
C	12.8	13.0	13.2	0.504	0.512	0.519
D	20.2			0.795		
N	60			2.362		
T			14.4			0.567
Ao	3.13	3.23	3.33	0.123	0.127	0.131
Bo	3.07	3.17	3.27	0.120	0.124	0.128
Ko	1.27	1.37	1.47	0.050	0.054	0.058
Po	3.9	4.0	4.1	0.153	0.157	0.161
P	3.9	4.0	4.1	0.153	0.157	0.161

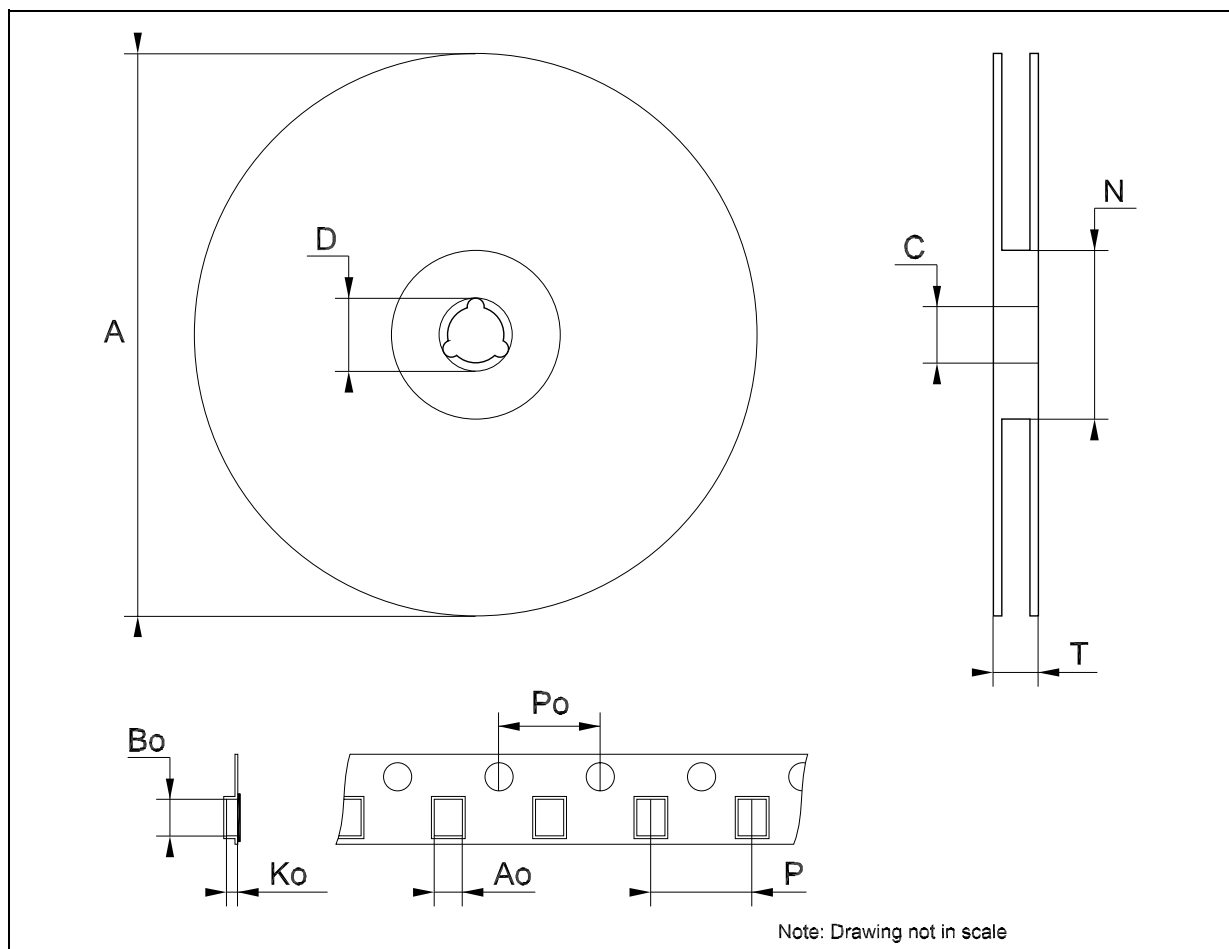

Information furnished is believed to be accurate and reliable. However, STMicroelectronics assumes no responsibility for the consequences of use of such information nor for any infringement of patents or other rights of third parties which may result from its use. No license is granted by implication or otherwise under any patent or patent rights of STMicroelectronics. Specifications mentioned in this publication are subject to change without notice. This publication supersedes and replaces all information previously supplied. STMicroelectronics products are not authorized for use as critical components in life support devices or systems without express written approval of STMicroelectronics.

© The ST logo is a registered trademark of STMicroelectronics

© 2003 STMicroelectronics - Printed in Italy - All Rights Reserved
STMicroelectronics GROUP OF COMPANIES

Australia - Brazil - Canada - China - Finland - France - Germany - Hong Kong - India - Israel - Italy - Japan - Malaysia - Malta - Morocco
Singapore - Spain - Sweden - Switzerland - United Kingdom - United States.

© <http://www.st.com>

