

DS10BR150 1.0 Gbps LVDS Buffer / Repeater

General Description

The DS10BR150 is a single channel 1.0 Gbps LVDS buffer optimized for high-speed signal transmission over lossy FR-4 printed circuit board backplanes and balanced cables. Fully differential signal paths ensure exceptional signal integrity and noise immunity.

Wide input common mode range allows the receiver to accept signals with LVDS, CML and LVPECL levels; the output levels are LVDS. A very small package footprint requires a minimal space on the board while the flow-through pinout allows easy board layout. The differential inputs and outputs are internally terminated with a 100 Ω resistor to lower device input and output return losses, reduce component count and further minimize board space.

Features

- DC - 1.0 Gbps low jitter, high noise immunity, low power operation
- On-chip 100 Ω input and output termination minimizes insertion and return losses, reduces component count and minimizes board space
- 7 kV ESD on LVDS I/O pins protects adjoining components
- Small 3 mm x 3 mm 8-LLP space saving package

Applications

- Clock and data buffering
- OC-12 / STM-4
- Fibre Channel (1GFC)
- FireWire 800

Typical Application

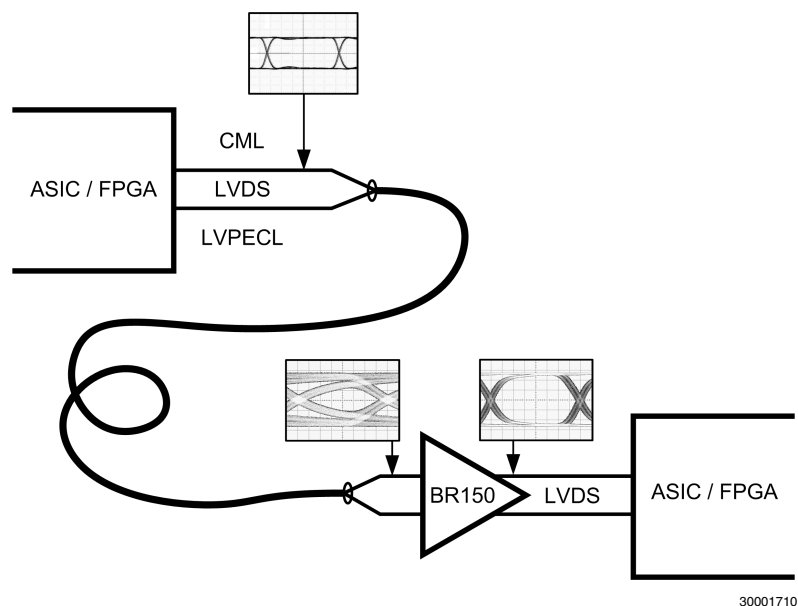

Block Diagram

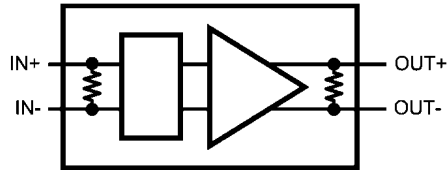

30001701

Pin Diagram

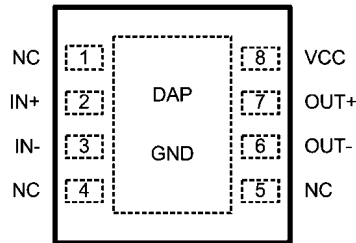

30001702

Pin Descriptions

Pin Name	Pin Name	Pin Type	Pin Description
NC	1	NA	"NO CONNECT" pin.
IN+	2	Input	Non-inverting LVDS input pin.
IN-	3	Input	Inverting LVDS input pin.
NC	4	NA	"NO CONNECT" pin.
NC	5	NA	"NO CONNECT" pin.
OUT-	6	Output	Inverting LVDS output pin.
OUT+	7	Output	Non-inverting LVDS Output pin.
VCC	8	Power	Power supply pin.
GND	DAP	Power	Ground pad (DAP - die attach pad)

Ordering Code

NSID	Function
DS10BR150TSD	Buffer / Repeater

Absolute Maximum Ratings (Note 4)

If Military/Aerospace specified devices are required, please contact the National Semiconductor Sales Office/ Distributors for availability and specifications.

Supply Voltage (V_{CC})	-0.3V to +4V
LVDS Input Voltage (IN+, IN-)	-0.3V to +4V
LVDS Differential Input Voltage ((IN+) - (IN-))	0V to 1V
LVDS Output Voltage (OUT+, OUT-)	-0.3V to +4V
LVDS Differential Output Voltage ((OUT+) - (OUT-))	0V to 1V
LVDS Output Short Circuit Current Duration	5 ms
Junction Temperature	+150°C
Storage Temperature Range	-65°C to +150°C
Lead Temperature Range	
Soldering (4 sec.)	+260°C
Maximum Package Power Dissipation at 25°C	
SDA Package	2.08W
Derate SDA Package	16.7 mW/°C above +25°C

Package Thermal Resistance

θ_{JA}	+60.0°C/W
θ_{JC}	+12.3°C/W

ESD Susceptibility

HBM	≥7 kV
MM	≥250V
CDM	≥1250V

Note 1: Human Body Model, applicable std. JESD22-A114C

Note 2: Machine Model, applicable std. JESD22-A115-A

Note 3: Field Induced Charge Device Model, applicable std. JESD22-C101-C

Recommended Operating Conditions

	Min	Typ	Max	Units
Supply Voltage (V_{CC})	3.0	3.3	3.6	V
Receiver Differential Input Voltage (V_{ID})	0		1	V
Operating Free Air Temperature (T_A)	-40	+25	+85	°C

DC Electrical Characteristics

Over recommended operating supply and temperature ranges unless otherwise specified. (Notes 5, 6, 7)

Symbol	Parameter	Conditions	Min	Typ	Max	Units	
LVDS OUTPUT DC SPECIFICATIONS (OUT+, OUT-)							
V_{OD}	Differential Output Voltage	$R_L = 100\Omega$	250	350	450	mV	
ΔV_{OD}	Change in Magnitude of V_{OD} for Complimentary Output States		-35		35	mV	
V_{OS}	Offset Voltage	$R_L = 100\Omega$	1.05	1.2	1.375	V	
ΔV_{OS}	Change in Magnitude of V_{OS} for Complimentary Output States		-35		35	mV	
I_{OS}	Output Short Circuit Current (Note 8)	OUT to GND		-30	-50	mA	
		OUT to V_{CC}		7.5	50	mA	
C_{OUT}	Output Capacitance	Any LVDS Output Pin to GND		1.2		pF	
R_{OUT}	Output Termination Resistor	Between OUT+ and OUT- Pins		100		Ω	
LVDS INPUT DC SPECIFICATIONS (IN+, IN-)							
V_{ID}	Input Differential Voltage	$V_{CM} = +0.05V$ or $V_{CC}-0.05V$	0		1	V	
V_{TH}	Differential Input High Threshold				0	+100	mV
V_{TL}	Differential Input Low Threshold			-100	0		mV
V_{CMR}	Common Mode Voltage Range	$V_{ID} = 100$ mV	0.05		$V_{CC} - 0.05$	V	
I_{IN}	Input Current	$V_{IN} = 3.6V$ or $0V$ $V_{CC} = 3.6V$ or $0V$		±1	±10	μA	
C_{IN}	Input Capacitance			1.7		pF	
R_{IN}	Input Termination Resistor	Between IN+ and IN- Pins		100		Ω	
SUPPLY CURRENT							
I_{CCD}	Total Supply Current			16	21	mA	

AC Electrical Characteristics (Note 9)

Over recommended operating supply and temperature ranges unless otherwise specified. (Notes 5, 7)

Symbol	Parameter	Conditions	Min	Typ	Max	Units	
LVDS OUTPUT AC SPECIFICATIONS (OUT+, OUT-)							
t_{PHLD2}	Differential Propagation Delay High to Low	$R_L = 100\Omega$		380	600	ps	
t_{PLHD2}	Differential Propagation Delay Low to High			410	600	ps	
t_{SKD1}	Pulse Skew $ t_{PLHD} - t_{PHLD} $ (Note 10)			30	150	ps	
t_{SKD2}	Part to Part Skew (Note 11)			45	160	ps	
t_{LHT}	Rise Time	$R_L = 100\Omega$		165	400	ps	
t_{HLT}	Fall Time			155	400	ps	
JITTER PERFORMANCE (Figure 5)							
t_{DJ}	Deterministic Jitter (Peak-to-Peak Value) (Note 13)	$V_{ID} = 350\text{ mV}$ $V_{CM} = 1.2\text{ V}$ K28.5 (NRZ)	622 Mbps		12	39	ps
			1.06 Gbps		15	42	ps
t_{RJ}	Random Jitter (RMS Value) (Note 12)	$V_{ID} = 350\text{ mV}$ $V_{CM} = 1.2\text{ V}$ Clock (NRZ)	311 MHz		0.6	1.3	ps
			503 MHz		0.6	1.1	ps
t_{TJ}	Total Jitter (Peak to Peak Value) (Note 14)	$V_{ID} = 350\text{ mV}$ $V_{CM} = 1.2\text{ V}$ PRBS-23 (NRZ)	622 Mbps		0.02	0.04	UI_{P-P}
			1.06 Gbps		0.02	0.05	UI_{P-P}

Note 4: "Absolute Maximum Ratings" indicate limits beyond which damage to the device may occur, including inoperability and degradation of device reliability and/or performance. Functional operation of the device and/or non-degradation at the Absolute Maximum Ratings or other conditions beyond those indicated in the Recommended Operating Conditions is not implied. The Recommended Operating Conditions indicate conditions at which the device is functional and the device should not be operated beyond such conditions.

Note 5: The Electrical Characteristics tables list guaranteed specifications under the listed Recommended Operating Conditions except as otherwise modified or specified by the Electrical Characteristics Conditions and/or Notes. Typical specifications are estimations only and are not guaranteed.

Note 6: Current into device pins is defined as positive. Current out of device pins is defined as negative. All voltages are referenced to ground except V_{OD} and ΔV_{OD} .

Note 7: Typical values represent most likely parametric norms for $V_{CC} = +3.3\text{ V}$ and $T_A = +25^\circ\text{C}$, and at the Recommended Operation Conditions at the time of product characterization and are not guaranteed.

Note 8: Output short circuit current (I_{OS}) is specified as magnitude only, minus sign indicates direction only.

Note 9: Specification is guaranteed by characterization and is not tested in production.

Note 10: t_{SKD1} , $|t_{PLHD} - t_{PHLD}|$, is the magnitude difference in differential propagation delay time between the positive going edge and the negative going edge of the same channel.

Note 11: t_{SKD2} , Part to Part Skew, is defined as the difference between the minimum and maximum specified differential propagation delays. This specification applies to devices at the same V_{CC} and within 5°C of each other within the operating temperature range.

Note 12: Measured on a clock edge with a histogram and an accumulation of 1500 histogram hits. Input stimulus jitter is subtracted geometrically.

Note 13: Tested with a combination of the 110000101 (K28.5+ character) and 0011111010 (K28.5- character) patterns. Input stimulus jitter is subtracted algebraically.

Note 14: Measured on an eye diagram with a histogram and an accumulation of 3500 histogram hits. Input stimulus jitter is subtracted.

DC Test Circuits

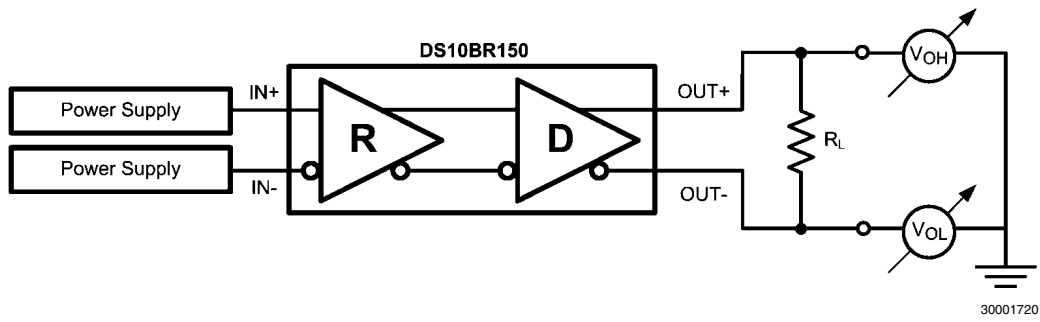

FIGURE 1. Differential Driver DC Test Circuit

AC Test Circuits and Timing Diagrams

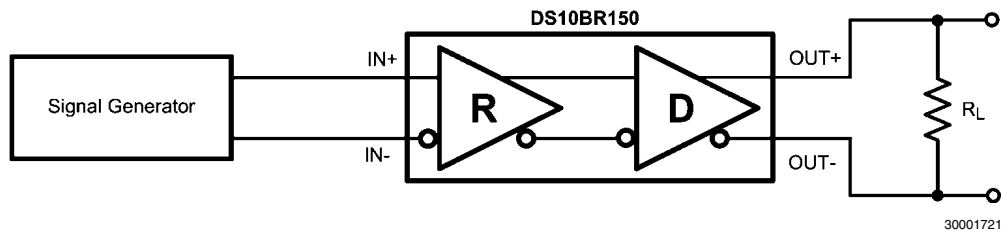

FIGURE 2. Differential Driver AC Test Circuit

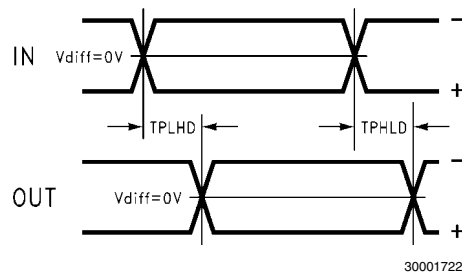

FIGURE 3. Propagation Delay Timing Diagram

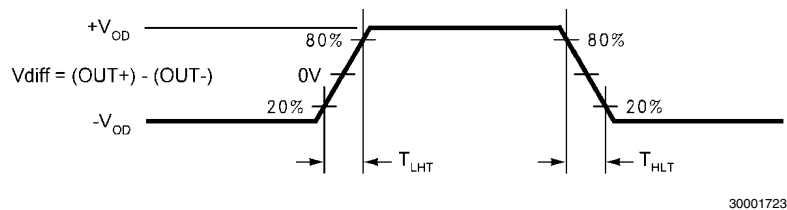
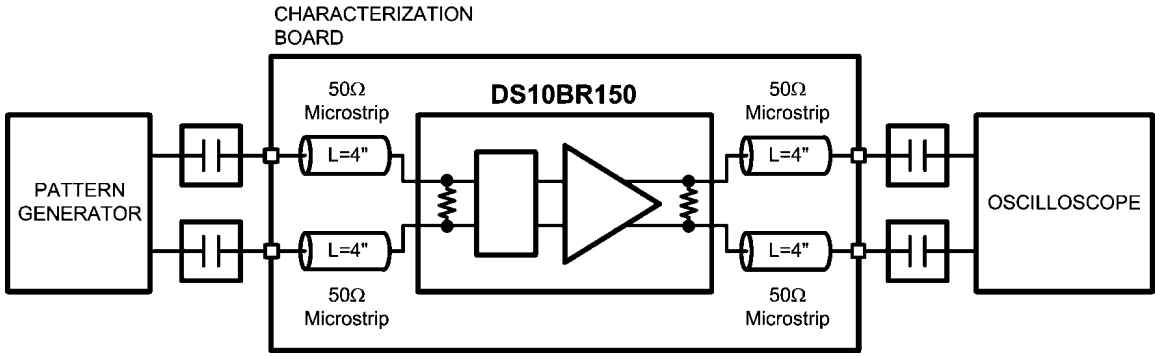

FIGURE 4. LVDS Output Transition Times



30001729

FIGURE 5. Jitter Measurements Test Circuit

Device Operation

INPUT INTERFACING

The DS10BR150 accepts differential signals and allows simple AC or DC coupling. With a wide common mode range, the DS10BR150 can be DC-coupled with all common differential drivers (i.e. LVPECL, LVDS, CML). The following three figures illustrate typical DC-coupled interface to common differential drivers. Note that the DS10BR150 inputs are internally terminated with a 100Ω resistor.

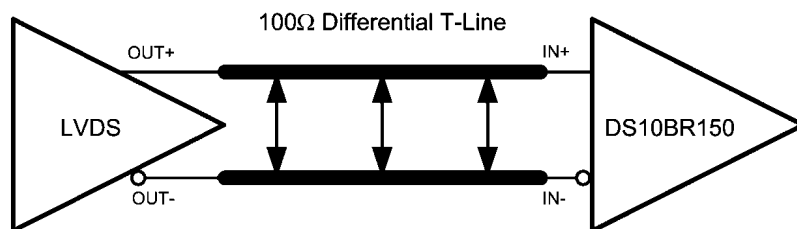

Typical LVDS Driver DC-Coupled Interface to DS10BR150 Input

30001711

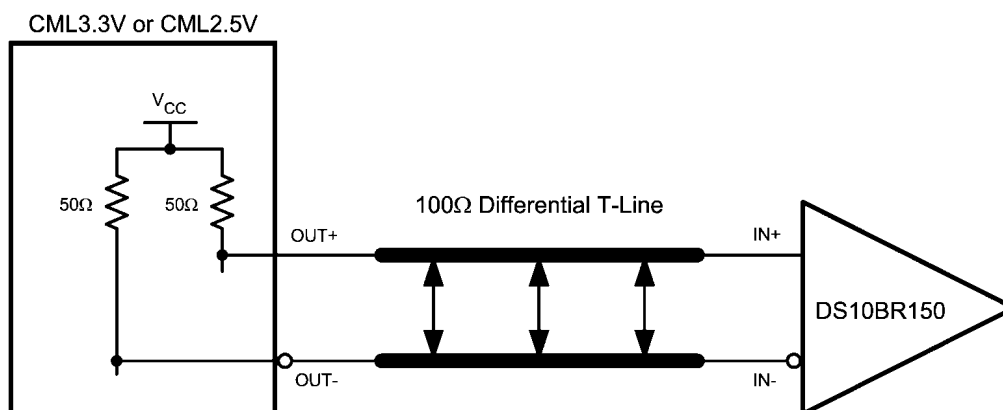

Typical CML Driver DC-Coupled Interface to DS10BR150 Input

30001712

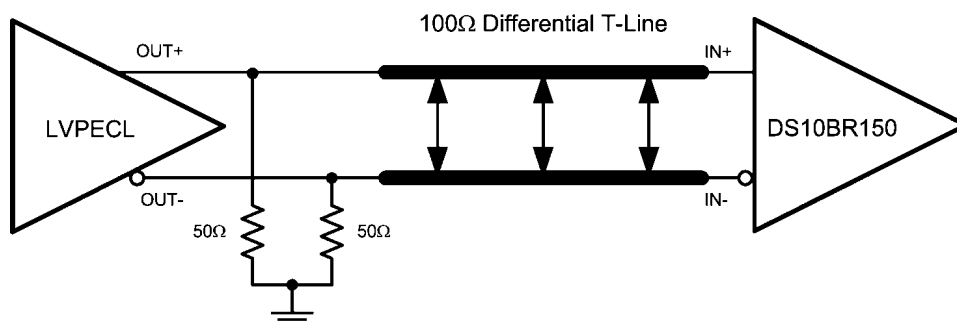

Typical LVPECL Driver DC-Coupled Interface to DS10BR150 Input

30001713

OUTPUT INTERFACING

The DS10BR150 outputs signals are compliant to the LVDS standard. It can be DC-coupled to most common differential receivers. The following figure illustrates typical DC-coupled interface to common differential receivers and assumes that the receivers have high impedance inputs. While most differential receivers have a common mode input range that can accommodate LVDS compliant signals, it is recommended to check respective receiver's data sheet prior to implementing the suggested interface implementation.

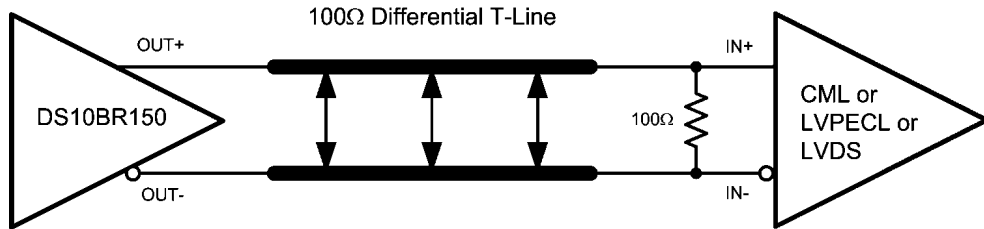

Typical DS10BR150 Output DC-Coupled Interface to an LVDS, CML or LVPECL Receiver

30001714

Typical Performance

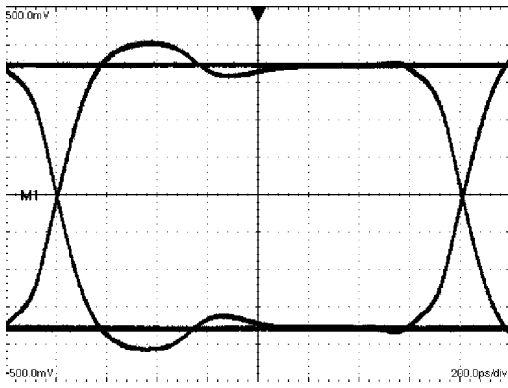

A 622 Mbps NRZ PRBS-7 Output Eye Diagram
 V:100 mV / DIV, H:200 ps / DIV

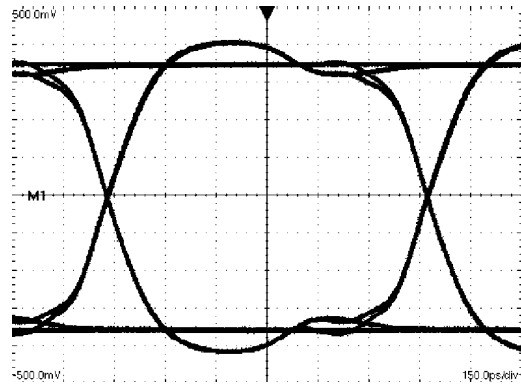

A 1062.5 Mbps NRZ PRBS-7 Output Eye Diagram
 V:100 mV / DIV, H:150 ps / DIV

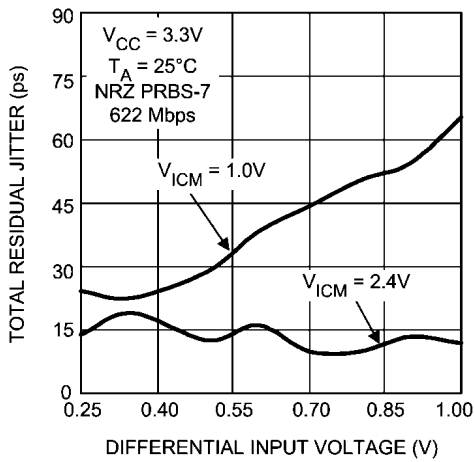

Total Jitter as a Function of Input Amplitude

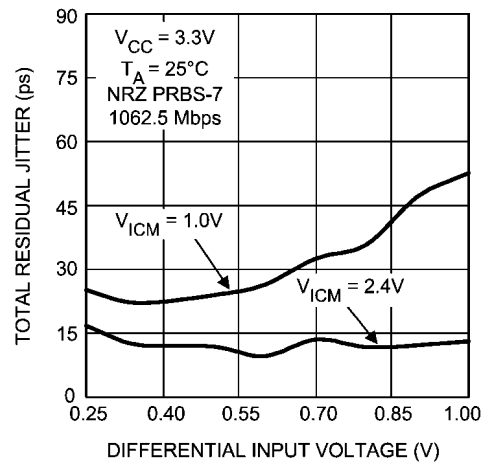

Total Jitter as a Function of Input Amplitude

Physical Dimensions inches (millimeters) unless otherwise noted

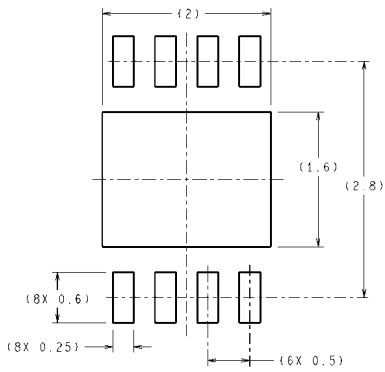

RECOMMENDED LAND PATTERN

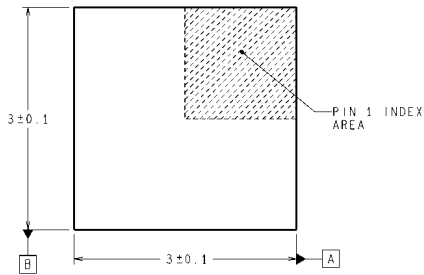

DIMENSIONS ARE IN MILLIMETERS
DIMENSIONS IN () FOR REFERENCE ONLY

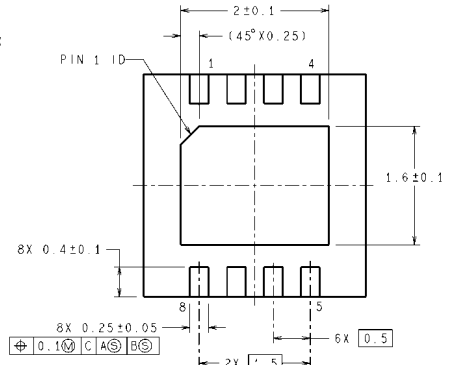
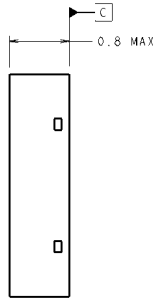
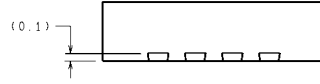

SDA08A (Rev A)

Order Number DS10BR150TSD
NS Package Number SDA08A
(See AN-1187 for PCB Design and Assembly Recommendations)

Notes

Notes

THE CONTENTS OF THIS DOCUMENT ARE PROVIDED IN CONNECTION WITH NATIONAL SEMICONDUCTOR CORPORATION ("NATIONAL") PRODUCTS. NATIONAL MAKES NO REPRESENTATIONS OR WARRANTIES WITH RESPECT TO THE ACCURACY OR COMPLETENESS OF THE CONTENTS OF THIS PUBLICATION AND RESERVES THE RIGHT TO MAKE CHANGES TO SPECIFICATIONS AND PRODUCT DESCRIPTIONS AT ANY TIME WITHOUT NOTICE. NO LICENSE, WHETHER EXPRESS, IMPLIED, ARISING BY ESTOPPEL OR OTHERWISE, TO ANY INTELLECTUAL PROPERTY RIGHTS IS GRANTED BY THIS DOCUMENT.

TESTING AND OTHER QUALITY CONTROLS ARE USED TO THE EXTENT NATIONAL DEEMS NECESSARY TO SUPPORT NATIONAL'S PRODUCT WARRANTY. EXCEPT WHERE MANDATED BY GOVERNMENT REQUIREMENTS, TESTING OF ALL PARAMETERS OF EACH PRODUCT IS NOT NECESSARILY PERFORMED. NATIONAL ASSUMES NO LIABILITY FOR APPLICATIONS ASSISTANCE OR BUYER PRODUCT DESIGN. BUYERS ARE RESPONSIBLE FOR THEIR PRODUCTS AND APPLICATIONS USING NATIONAL COMPONENTS. PRIOR TO USING OR DISTRIBUTING ANY PRODUCTS THAT INCLUDE NATIONAL COMPONENTS, BUYERS SHOULD PROVIDE ADEQUATE DESIGN, TESTING AND OPERATING SAFEGUARDS.

EXCEPT AS PROVIDED IN NATIONAL'S TERMS AND CONDITIONS OF SALE FOR SUCH PRODUCTS, NATIONAL ASSUMES NO LIABILITY WHATSOEVER, AND NATIONAL DISCLAIMS ANY EXPRESS OR IMPLIED WARRANTY RELATING TO THE SALE AND/OR USE OF NATIONAL PRODUCTS INCLUDING LIABILITY OR WARRANTIES RELATING TO FITNESS FOR A PARTICULAR PURPOSE, MERCHANTABILITY, OR INFRINGEMENT OF ANY PATENT, COPYRIGHT OR OTHER INTELLECTUAL PROPERTY RIGHT.

LIFE SUPPORT POLICY

NATIONAL'S PRODUCTS ARE NOT AUTHORIZED FOR USE AS CRITICAL COMPONENTS IN LIFE SUPPORT DEVICES OR SYSTEMS WITHOUT THE EXPRESS PRIOR WRITTEN APPROVAL OF THE CHIEF EXECUTIVE OFFICER AND GENERAL COUNSEL OF NATIONAL SEMICONDUCTOR CORPORATION. As used herein:

Life support devices or systems are devices which (a) are intended for surgical implant into the body, or (b) support or sustain life and whose failure to perform when properly used in accordance with instructions for use provided in the labeling can be reasonably expected to result in a significant injury to the user. A critical component is any component in a life support device or system whose failure to perform can be reasonably expected to cause the failure of the life support device or system or to affect its safety or effectiveness.

National Semiconductor and the National Semiconductor logo are registered trademarks of National Semiconductor Corporation. All other brand or product names may be trademarks or registered trademarks of their respective holders.

Copyright© 2007 National Semiconductor Corporation

For the most current product information visit us at www.national.com



**National Semiconductor
Americas Customer
Support Center**
Email:
new.feedback@nsc.com
Tel: 1-800-272-9959

**National Semiconductor Europe
Customer Support Center**
Fax: +49 (0) 180-530-85-86
Email: europe.support@nsc.com
Deutsch Tel: +49 (0) 69 9508 6208
English Tel: +49 (0) 870 24 0 2171
Français Tel: +33 (0) 1 41 91 8790

**National Semiconductor Asia
Pacific Customer Support Center**
Email: ap.support@nsc.com

**National Semiconductor Japan
Customer Support Center**
Fax: 81-3-5639-7507
Email: jpn.feedback@nsc.com
Tel: 81-3-5639-7560