

## Low Charge Injection 8-Channel High Voltage Analog Switch with Bleed Resistors

### Ordering Information

$V_{PP} - V_{NN}$	Package Options			
	28-lead plastic chip carrier	48-lead TQFP	$\mu$ -BGA	Die
200V	HV232PJ	HV232FG	HV232GA	HV232X

### Features

- HVCMOS<sup>®</sup> technology for high performance
- Very low quiescent power dissipation – 10 $\mu$ A
- Output On-resistance typically 22 ohms
- Integrated bleed resistors on the outputs
- Low parasitic capacitances
- DC to 10MHz analog signal frequency
- 60dB typical output off isolation at 5MHz
- CMOS logic circuitry for low power
- Excellent noise immunity
- On-chip shift register, latch and clear logic circuitry
- Flexible high voltage supplies
- Surface mount package available

### General Description

The Supertex HV232 is a low charge injection 8-channel high-voltage analog switch integrated circuit (IC) with bleed resistors. The device can be used in applications requiring high voltage switching controlled by low voltage control signals, such as ultrasound imaging and printers. The bleed resistors eliminate voltage built up on capacitive loads such as piezoelectric transducers. Input data is shifted into an 8-bit shift register which can then be retained in an 8-bit latch. To reduce any possible clock feed-through noise, Latch Enable Bar (LE) should be left high until all bits are clocked in. Using HVCMOS technology, this switch combines high voltage bilateral DMOS switches and low power CMOS logic to provide efficient control of high voltage analog signals.

This IC is suitable for various combinations of high voltage supplies, e.g.,  $V_{PP}/V_{NN}$  : +50V/-150V, or +100V/-100V.

### Absolute Maximum Ratings\*

$V_{DD}$ Logic power supply voltage	-0.5V to +15V	
$V_{PP} - V_{NN}$ Supply voltage	220V	
$V_{PP}$ Positive high voltage supply	-0.5V to $V_{NN} + 200V$	
$V_{NN}$ Negative high voltage supply	+0.5V to -200V	
Logic input voltages	-0.5V to $V_{DD} + 0.3V$	
Analog Signal Range	$V_{NN}$ to $V_{PP}$	
Peak analog signal current/channel	3.0A	
Storage temperature	-65°C to +150°C	
Power dissipation	$\mu$ -BGA	1.0W
	28-pin PLCC	1.2W
	48 lead TQFP	1.0W

\* Absolute Maximum Ratings are those values beyond which damage to the device may occur. Functional operation under these conditions is not implied. Continuous operation of the device at the absolute rating level may affect device reliability.

# Electrical Characteristics

**DC Characteristics** (over recommended operating conditions unless otherwise noted)

Characteristics	Sym	0°C		+25°C			+70°C		Units	Test Conditions	
		min	max	min	typ	max	min	max			
Small Signal Switch (ON) Resistance	R <sub>ONS</sub>		30		26	38		48	ohms	I <sub>SIG</sub> = 5mA	V <sub>PP</sub> = 40V,
			25		22	27		32		I <sub>SIG</sub> = 200mA	V <sub>NN</sub> = -160V
			25		22	27		30		I <sub>SIG</sub> = 5mA	V <sub>PP</sub> = 100V,
			18		18	24		27		I <sub>SIG</sub> = 200mA	V <sub>NN</sub> = -100V
			23		20	25		30		I <sub>SIG</sub> = 5mA	V <sub>PP</sub> = 160V,
			22		16	25		27		I <sub>SIG</sub> = 200mA	V <sub>NN</sub> = -40V
Small Signal Switch (ON) Resistance Matching	ΔR <sub>ONS</sub>		20		5.0	20		20	%	I <sub>SW</sub> = 5mA, V <sub>PP</sub> = 100V, V <sub>NN</sub> = -100V	
Large Signal Switch (ON) Resistance	R <sub>ONL</sub>				15				ohms	V <sub>SIG</sub> = V <sub>PP</sub> - 10V, I <sub>SIG</sub> = 1A	
Output Switch Shunt Resistance	R <sub>INT</sub>			20	35	50			KΩ	Output switch to R <sub>GND</sub>	
Switch Off Leakage Per Switch	I <sub>SOL</sub>		5.0		1.0	10		15	μA	V <sub>SIG</sub> = V <sub>PP</sub> - 10V	
DC Offset Switch Off			300		100	300		300	mV	No Load	
DC Offset Switch On			500		100	500		500	mV	No Load	
Pos. HV Supply Current	I <sub>PPQ</sub>				10	50			μA	ALL SWs OFF	
Neg. HV Supply Current	I <sub>NNQ</sub>				-10	-50			μA	ALL SWs OFF	
Pos. HV Supply Current	I <sub>PPQ</sub>				10	50			μA	ALL SWs ON, I <sub>SW</sub> = 5mA	
Neg. HV Supply Current	I <sub>NNQ</sub>				-10	-50			μA	ALL SWs ON, I <sub>SW</sub> = 5mA	
Switch Output Peak Current			3.0		3.0	2.0		2.0	A	V <sub>SIG</sub> duty cycle ≤ 0.1%	
Output Switch Frequency	f <sub>SW</sub>					50			KHz	Duty Cycle = 50%	
I <sub>PP</sub> Supply Current	I <sub>PP</sub>		6.5			7.0		8.0	mA	V <sub>PP</sub> = 40V, V <sub>NN</sub> = -160V	50KHz Output Switching Frequency with no load
			4.0			5.0		5.5		V <sub>PP</sub> = 100V, V <sub>NN</sub> = -100V	
			4.0			5.0		5.5		V <sub>PP</sub> = 160V, V <sub>NN</sub> = -40V	
I <sub>NN</sub> Supply Current	I <sub>NN</sub>		6.5			7.0		8.0	mA	V <sub>PP</sub> = 40V, V <sub>NN</sub> = -160V	
			4.0			5.0		5.5		V <sub>PP</sub> = 100V, V <sub>NN</sub> = -100V	
			4.0			5.0		5.5		V <sub>PP</sub> = 160V, V <sub>NN</sub> = -40V	
Logic Supply Average Current	I <sub>DD</sub>		4.0			4.0		4.0	mA	f <sub>CLK</sub> = 5MHz, V <sub>DD</sub> = 5.0V	
Logic Supply Quiescent Current	I <sub>DDQ</sub>		10			10		10	μA		
Data Out Source Current	I <sub>SOR</sub>	0.45		0.45	0.70		0.40		mA	V <sub>OUT</sub> = V <sub>DD</sub> - 0.7V	
Data Out Sink Current	I <sub>SINK</sub>	0.45		0.45	0.70		0.40		mA	V <sub>OUT</sub> = 0.7V	
Logic Input Capacitance	C <sub>IN</sub>		10			10		10	pF		

# Electrical Characteristics

**AC Characteristics** (over operating conditions  $V_{DD} = 5V$ , unless otherwise noted)

Characteristics	Sym	0°C		+25°C			+70°C		Units	Test Conditions
		min	max	min	typ	max	min	max		
Set Up Time Before $\overline{LE}$ Rises	$t_{SD}$	150		150			150		ns	
Time Width of $\overline{LE}$	$t_{WLE}$	150		150			150		ns	
Clock Delay Time to Data Out	$t_{DO}$	55	150	60		150	70	150	ns	
Time Width of CL	$t_{WCL}$	150		150			150		ns	
Set Up Time Data to Clock	$t_{SU}$	15		15	8.0		20		ns	
Hold Time Data from Clock	$t_h$	35		35			35		ns	
Clock Freq	$f_{CLK}$		5.0			5.0		5.0	MHz	50% duty cycle $f_{DATA} = f_{CLK}/2$
Clock Rise and Fall Times	$t_r, t_f$		1.0			1.0		1.0	$\mu s$	
Turn On Time	$t_{ON}$		5.0			5.0		5.0	$\mu s$	$V_{SIG} = V_{PP} - 10V$ , $R_L = 10K\Omega$
Turn Off Time	$t_{OFF}$		5.0			5.0		5.0	$\mu s$	$V_{SIG} = V_{PP} - 10V$ , $R_L = 10K\Omega$
Maximum $V_{SIG}$ Slew Rate	dv/dt		20			20		20	V/ns	$V_{PP} = 160V$ , $V_{NN} = -40V$
			20			20		20		$V_{PP} = 100V$ , $V_{NN} = -100V$
			20			20		20		$V_{PP} = 40V$ , $V_{NN} = -160V$
Off Isolation	KO	-30		-30	-33		-30		dB	$f = 5MHz$ , 1K $\Omega$ //15pF load
		-58		-58			-58		dB	$f = 5MHz$ , 50 $\Omega$ load
Switch Crosstalk	$K_{CR}$	-60		-60	-70		-60		dB	$f = 5MHz$ , 50 $\Omega$ load
Output Switch Isolation Diode Current	$I_{ID}$		300			300		300	mA	300ns pulse width, 2.0% duty cycle
Off Capacitance SW to GND	$C_{SG(OFF)}$	5.0	17	5.0	12	17	5.0	17	pF	0V, 1MHz
On Capacitance SW to GND	$C_{SG(ON)}$	25	50	25	38	50	25	50	pF	0V, 1MHz

## Electrical Characteristics

**AC Characteristics** (over operating conditions  $V_{DD} = 5V$ , unless otherwise noted)

Characteristics	Sym	+25°C			Units	Test Conditions
		min	typ	max		
Output Voltage Spike	+V <sub>SPK</sub>			150	mV	V <sub>PP</sub> = 40V, V <sub>NN</sub> = -160V, R <sub>L</sub> = 50Ω
	-V <sub>SPK</sub>			150		
	+V <sub>SPK</sub>			150		V <sub>PP</sub> = 100V, V <sub>NN</sub> = -100V, R <sub>L</sub> = 50Ω
	-V <sub>SPK</sub>			150		
	+V <sub>SPK</sub>			150		V <sub>PP</sub> = 160V, V <sub>NN</sub> = -40V, R <sub>L</sub> = 50Ω
	-V <sub>SPK</sub>			150		

## Operating Conditions\*

Symbol	Parameter	Value
V <sub>DD</sub>	Logic power supply voltage <sup>1, 3</sup>	4.5V to 13.2V
V <sub>PP</sub>	Positive high voltage supply <sup>1, 3</sup>	40V to V <sub>NN</sub> + 200V
V <sub>NN</sub>	Negative high voltage supply <sup>1, 3</sup>	-40V to -160V
V <sub>IH</sub>	High-level input voltage	V <sub>DD</sub> -1.5V to V <sub>DD</sub>
V <sub>IL</sub>	Low-level input voltage	0V to 1.5V
V <sub>SIG</sub>	Analog signal voltage peak to peak	V <sub>NN</sub> +10V to V <sub>PP</sub> -10V <sup>2</sup>
T <sub>A</sub>	Operating free air-temperature	0°C to 70°C

**Notes:**

- 1 Power up/down sequence is arbitrary except GND must be powered-up first and powered-down last.
- 2 V<sub>SIG</sub> must be V<sub>NN</sub> ≤ V<sub>SIG</sub> ≤ V<sub>PP</sub> or floating during power up/down transition.
- 3 Rise and fall times of power supplies V<sub>DD</sub>, V<sub>PP</sub>, and V<sub>NN</sub> should not be less than 1.0msec.

# Test Circuits

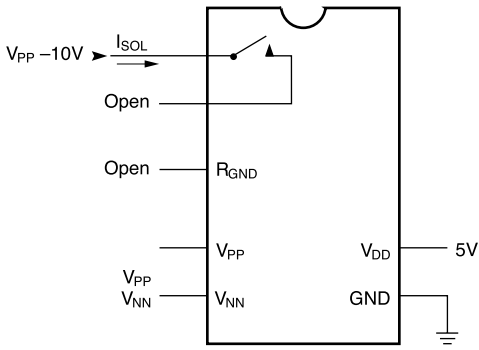

Switch OFF Leakage

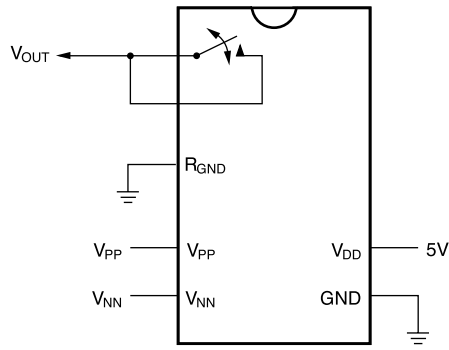

DC Offset ON/OFF

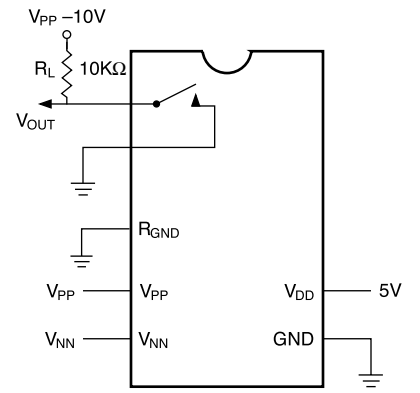

T<sub>ON</sub>/T<sub>OFF</sub> Test Circuit

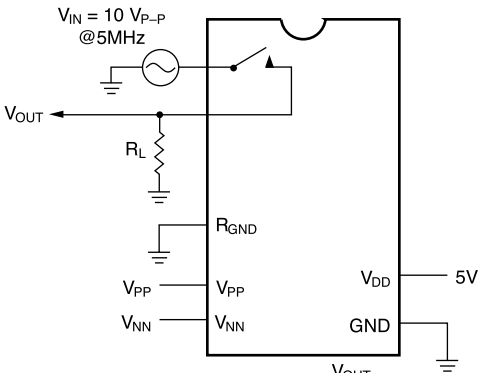

$K_O = 20 \text{Log} \frac{V_{OUT}}{V_{IN}}$   
OFF Isolation

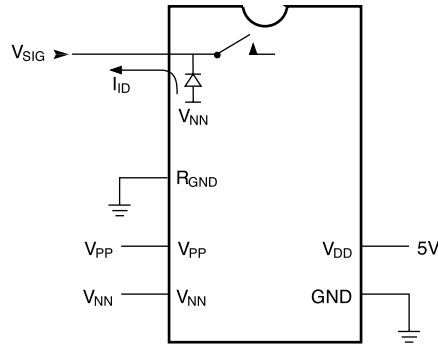

Isolation Diode Current

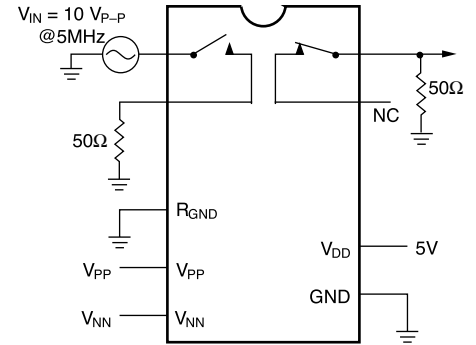

$K_{CR} = 20 \text{Log} \frac{V_{OUT}}{V_{IN}}$   
Crosstalk

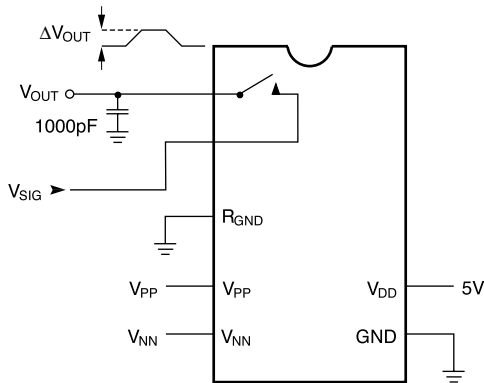

$Q = 1000 \text{pF} \times \Delta V_{OUT}$   
Charge Injection

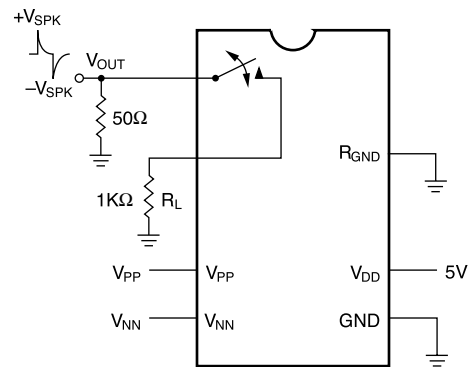

Output Voltage Spike

# Logic Timing Waveforms

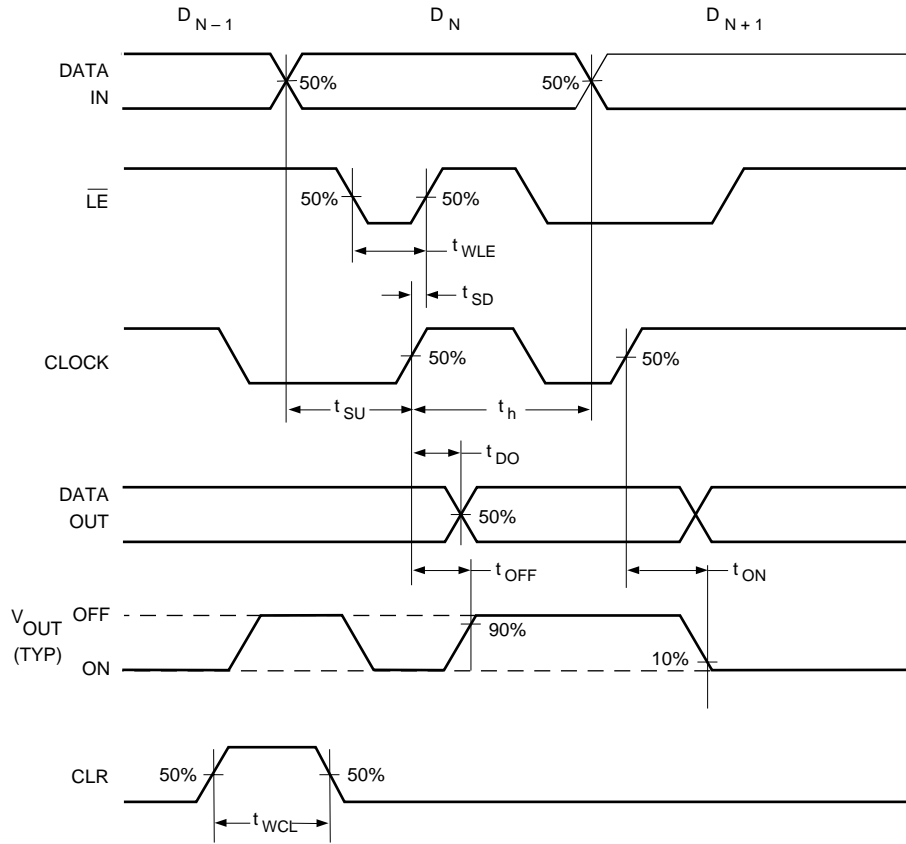

# Block Diagram

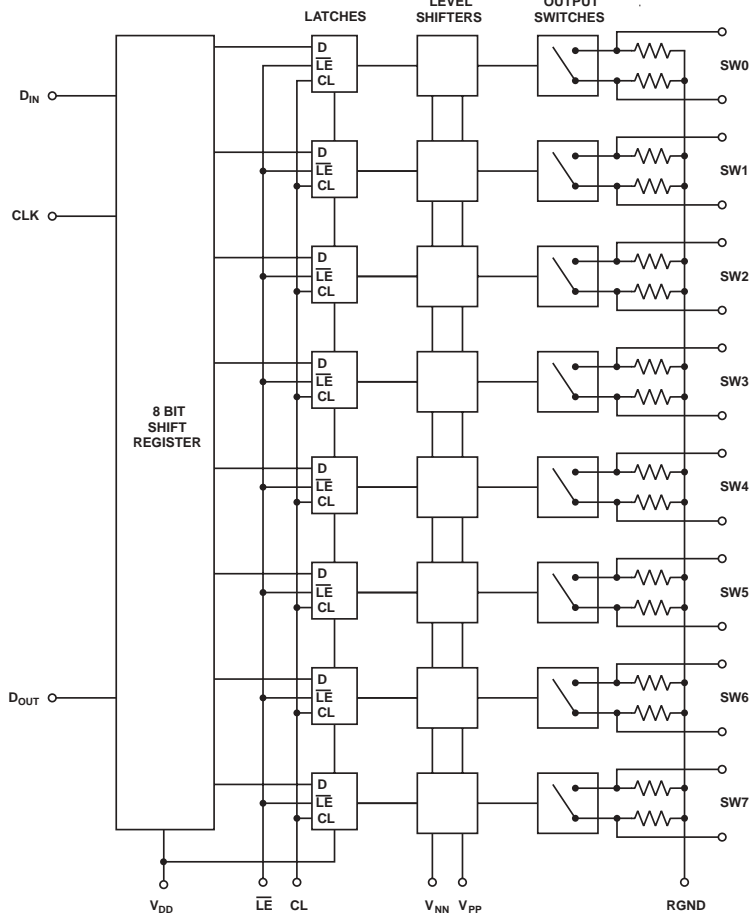

# Truth Table

D0	D1	D2	D3	D4	D5	D6	D7	$\overline{LE}$	CL	SW0	SW1	SW2	SW3	SW4	SW5	SW6	SW7
L								L	L	OFF							
H								L	L	ON							
	L							L	L		OFF						
	H							L	L		ON						
		L						L	L			OFF					
		H						L	L			ON					
			L					L	L				OFF				
			H					L	L				ON				
				L				L	L					OFF			
				H				L	L					ON			
					L			L	L						OFF		
					H			L	L						ON		
						L		L	L							OFF	
						H		L	L							ON	
							L	L	L								OFF
							H	L	L								ON
X	X	X	X	X	X	X	X	X	H	L	HOLD PREVIOUS STATE						
X	X	X	X	X	X	X	X	X	H	OFF	OFF	OFF	OFF	OFF	OFF	OFF	OFF

**Notes:**

1. The eight switches operate independently.
2. Serial data is clocked in on the L→ H transition CLK.
3. The switches go to a state retaining their present condition at the rising edge of  $\overline{LE}$ . When  $\overline{LE}$  is low the shift register data flows through the latch.
4.  $D_{OUT}$  is high when switch 7 is on.
5. Shift register clocking has no effect on the switch states if  $\overline{LE}$  is H.
6. The clear input overrides all other inputs.

# Pin Configurations

# Package Outlines

## HV232 28 Pin J-Lead

Pin	Function	Pin	Function
1	SW3	15	N/C
2	SW3	16	D <sub>IN</sub>
3	SW2	17	CLK
4	SW2	18	LE
5	SW1	19	CL
6	SW1	20	D <sub>OUT</sub>
7	SW0	21	SW7
8	SW0	22	SW7
9	N/C	23	SW6
10	V <sub>PP</sub>	24	SW6
11	R <sub>GND</sub>	25	SW5
12	V <sub>NN</sub>	26	SW5
13	GND	27	SW4
14	V <sub>DD</sub>	28	SW4

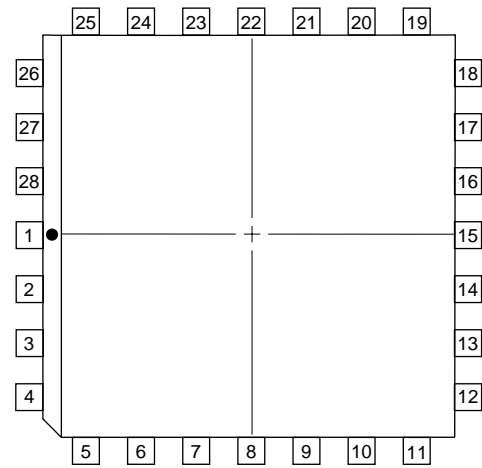

top view  
28-pin J-Lead Package

## HV232 48-Pin TQFP

Pin	Function	Pin	Function
1	SW5	25	V <sub>NN</sub>
2	N/C	26	N/C
3	SW4	27	R <sub>GND</sub>
4	N/C	28	GND
5	SW4	29	V <sub>DD</sub>
6	N/C	30	N/C
7	N/C	31	N/C
8	SW3	32	N/C
9	N/C	33	D <sub>IN</sub>
10	SW3	34	CLK
11	N/C	35	LE
12	SW2	36	CLR
13	N/C	37	D <sub>OUT</sub>
14	SW2	38	N/C
15	N/C	39	SW7
16	SW1	40	N/C
17	N/C	41	SW7
18	SW1	42	N/C
19	N/C	43	SW6
20	SW0	44	N/C
21	N/C	45	SW6
22	SW0	46	N/C
23	N/C	47	SW5
24	V <sub>PP</sub>	48	N/C

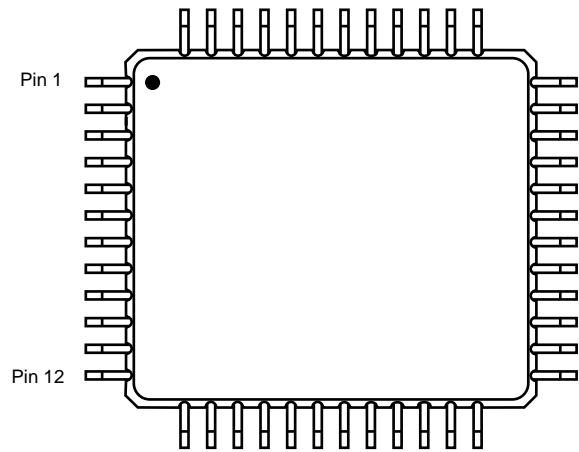

top view  
48-pin TQFP



# HV232GA Package Outline ( $\mu$ -BGA)

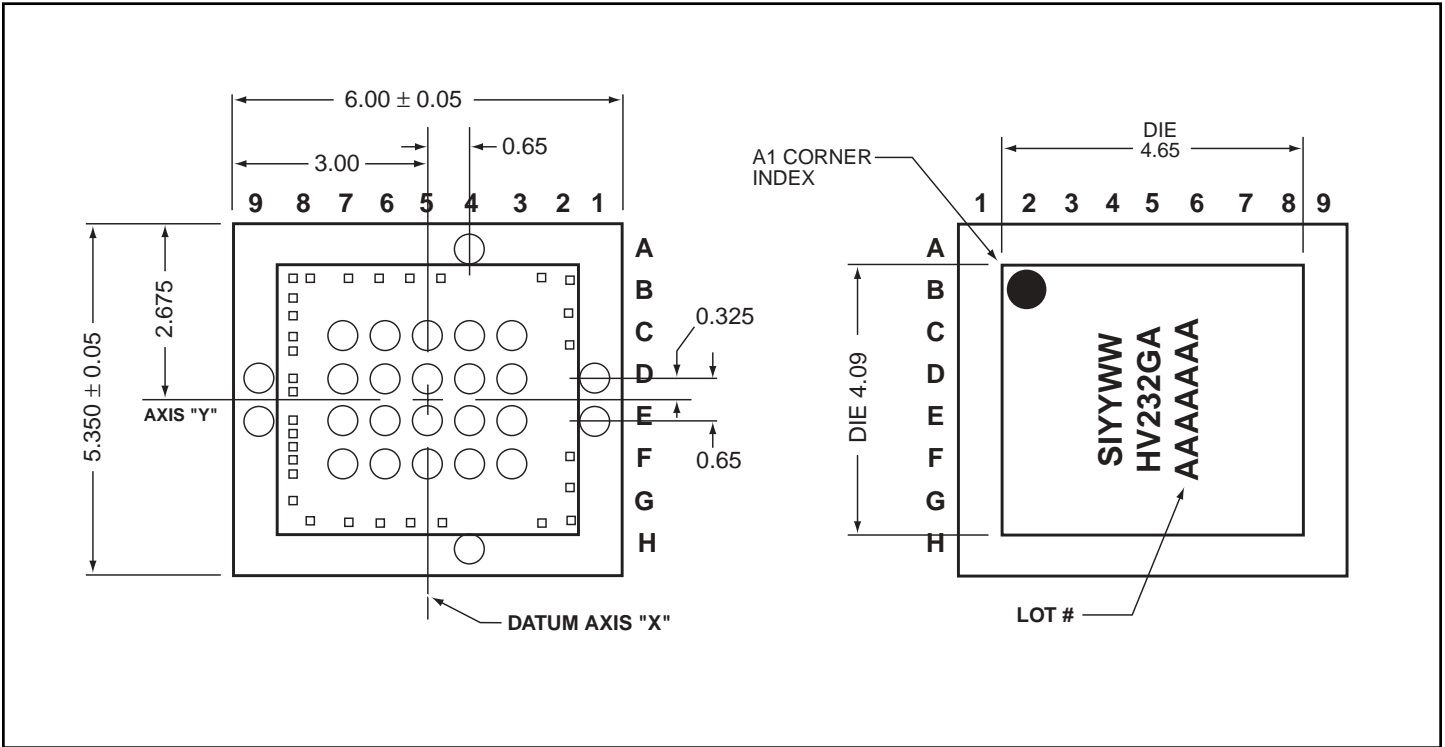

**Notes:**

1. Dimensioning and tolerance per ASME Y14.5M-1994.
2. Do not subject part to ultrasonic cleaning or intense UV.
3. Contact ball position per JESD 95-1, SPP-010.
4. Units are in millimeters.

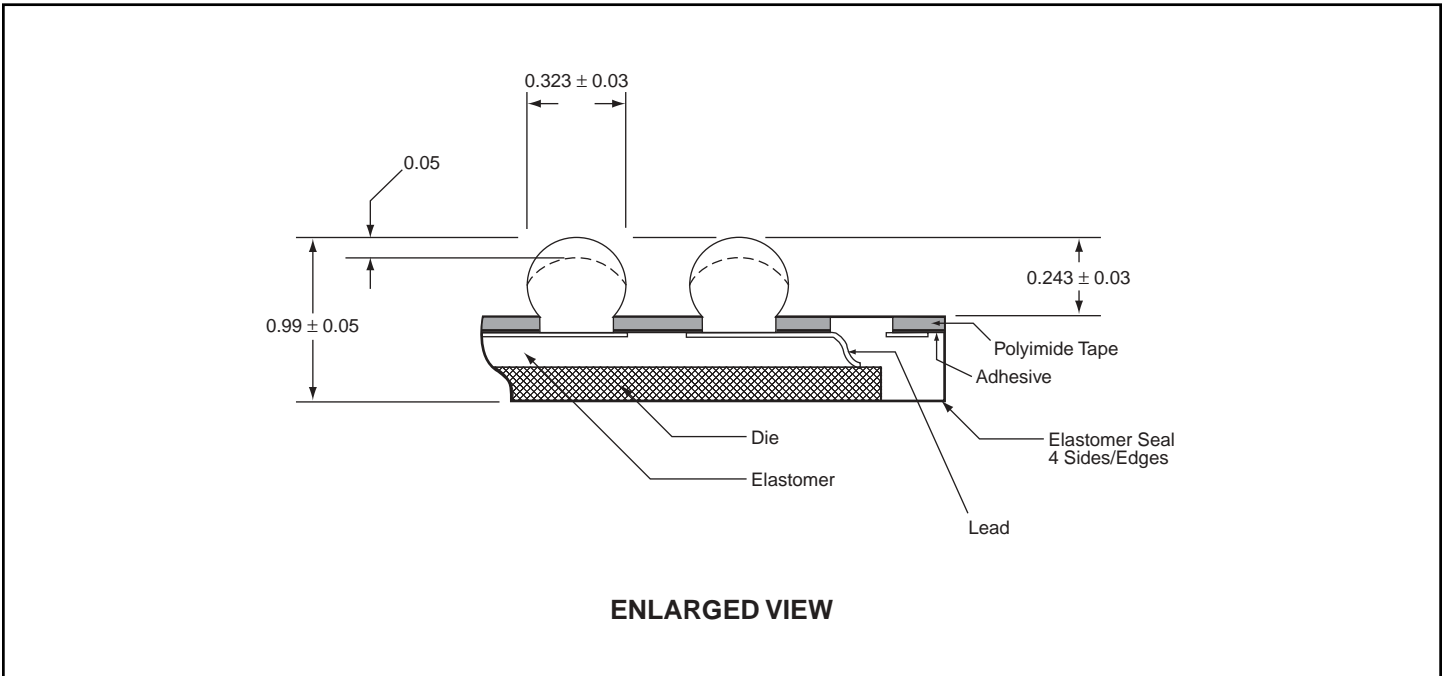

**μ-BGA Function Table**

Ball Location	Function
A4	SW1
C3	SW2
C4	SW1
C5	SW0
C6	V <sub>PP</sub>
C7	V <sub>NN</sub>
D1	SW3
D3	SW3
D4	SW2
D5	SW0
D6	R <sub>GND</sub>
D7	GND
D9	V <sub>DD</sub>
E1	SW4
E3	SW4
E4	SW5
E5	SW7
E6	$\overline{\text{LE}}$
E7	CLK
E9	D <sub>IN</sub>
F3	SW5
F4	SW6
F5	SW7
F6	D <sub>OUT</sub>
F7	CLR
H4	SW6