

High Voltage EL Lamp Driver for Low Noise Applications

Features

- ❑ Patent pending audible noise reduction
- ❑ Patent pending lamp aging compensation
- ❑ 190V_{PP} output voltage for higher brightness
- ❑ Patented output timing for high efficiency
- ❑ Single cell lithium ion compatible
- ❑ 150nA shutdown current
- ❑ Wide input voltage range 1.8V to 5.0V
- ❑ Separately adjustable lamp and converter frequencies
- ❑ Output voltage regulation
- ❑ Split supply capability

Applications

- ❑ LCD backlighting
- ❑ Mobile cellular phones
- ❑ PDAs
- ❑ Handheld wireless communication products
- ❑ Global Positioning Systems (GPS)

General Description

The Supertex HV857 is a high voltage driver designed for driving Electroluminescent (EL) lamps of up to 5 square inches. The input supply voltage range is from 1.8V to 5.0V. The device uses a single inductor and a minimum number of passive components. The nominal regulated output voltage that is applied to the EL lamp is $\pm 95V$. The chip can be enabled/disabled by connecting the resistor on R_{sw-osc} to V_{DD}/ground.

The HV857 has two internal oscillators, a switching MOSFET, and a high voltage EL lamp driver. The frequency for the switching MOSFET is set by an external resistor connected between the R_{sw-osc} pin and the supply pin V_{DD}. The EL lamp driver frequency is set by an external resistor connected between R_{EL-osc} pin and the V_{DD} pin. An external inductor is connected between the L_x and V_{DD} pins or V_{IN} for split supply applications. A 0.003-0.1 μ F capacitor is connected between C_s and ground. The EL lamp is connected between V_A and V_B.

The switching MOSFET charges the external inductor and discharges it into the capacitor at C_s. The voltage at C_s will start to increase. Once the voltage at C_s reaches a nominal value of 95V, the switching MOSFET is turned OFF to conserve power. The outputs V_A and V_B are configured as an H bridge and are switching in opposite states to achieve $\pm 95V$ across the EL lamp.

Typical Application

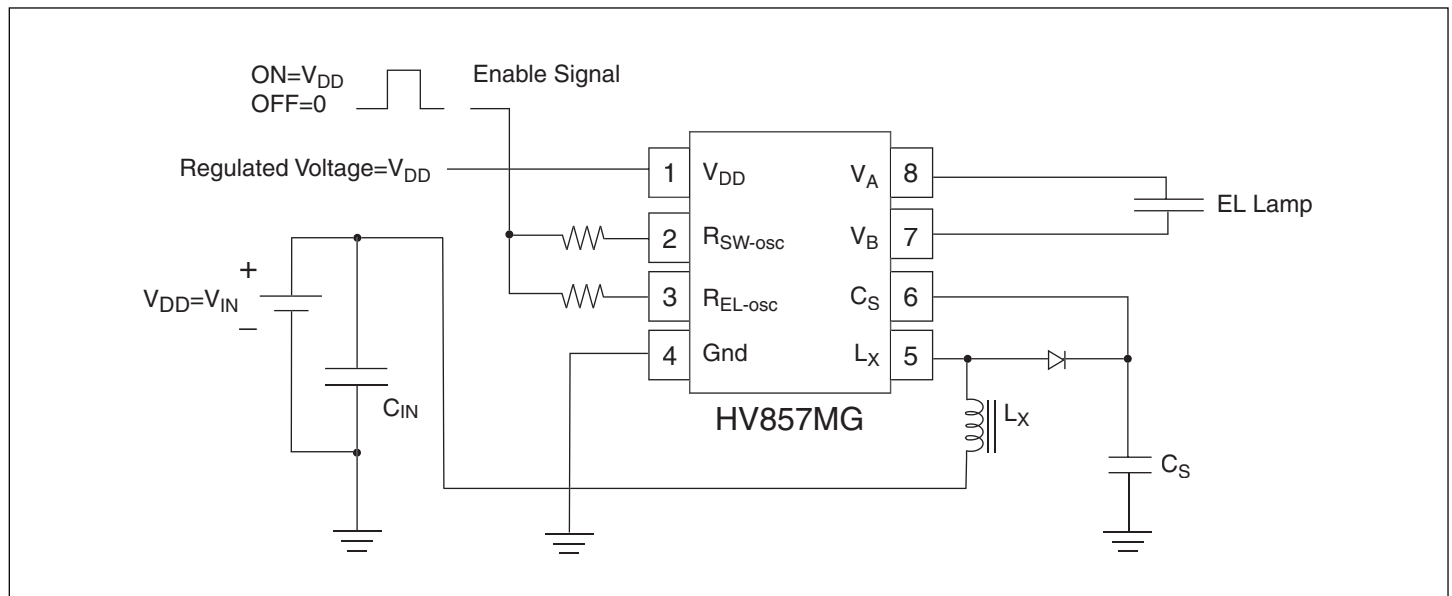

Electrical Characteristics

DC Characteristics (Over recommended operating conditions unless otherwise specified, $T_A=25^\circ\text{C}$)

Symbol	Parameter	Min	Typ	Max	Units	Conditions
$R_{DS(on)}$	On-resistance of switching transistor			6.0	Ω	$I=100\text{mA}$
V_{CS}	Max. output regulation voltage	85	95	105	V	$V_{DD}=1.8\text{V to }5.0\text{V}$
$V_A - V_B$	Peak to Peak output voltage	170	190	210	V	$V_{DD}=1.8\text{V to }5.0\text{V}$
I_{DDQ}	Quiescent V_{DD} supply current			150	nA	$R_{SW-OSC}=\text{Low}$
I_{DD}	Input current going into the V_{DD} pin			150	μA	$V_{DD}=1.8\text{V to }5.0\text{V}$. See Figure 1.
I_{IN}	Input current including inductor current		20	25	mA	See Figure 1.*
V_{CS}	Output voltage on V_{CS}		84		V	See Figure 1.
f_{EL}	EL lamp frequency	205	240	275	Hz	See Figure 1.
f_{SW}	Switching transistor frequency		80		KHz	See Figure 1.
D	Switching transistor duty cycle		88		%	See Figure 1.

* The inductor used is a $220\mu\text{H}$ Murata inductor, max DC resistance of 8.4Ω , part # LQH32CN221K21.

Recommended Operating Conditions

Symbol	Parameter	Min	Typ	Max	Units	Conditions
V_{DD}	Supply voltage	1.8		5.0	V	
f_{EL}	Output drive frequency			1	KHz	
T_A	Operating temperature	-40		85	$^\circ\text{C}$	

Enable/Disable Function Table

Symbol	Parameter	Min	Typ	Max	Units	Conditions
EN-L	Logic input low voltage	0		0.2	V	$V_{DD}=1.8\text{V to }5.0\text{V}$
EN-H	Logic input high voltage	$V_{DD}-0.2$		V_{DD}	V	$V_{DD}=1.8\text{V to }5.0\text{V}$

Absolute Maximum Ratings*

Supply Voltage, V_{DD}	-0.5V to +6.5V
Operating Temperature Range	-40 $^\circ\text{C}$ to +85 $^\circ\text{C}$
Storage Temperature Range	-65 $^\circ\text{C}$ to +150 $^\circ\text{C}$
MSOP-8 Power Dissipation	300mW
Output voltage, V_{CS}	-0.5 to +120V

Note:

*Absolute Maximum Ratings are those values beyond which damage to the device may occur. Functional operation under these conditions is not implied. Continuous operation of the device at the absolute rating level may affect device reliability. All voltages are referenced to device ground.

Ordering Information

Device	Package Options	
	MSOP-8	Die
HV857	HV857MG*	HV857X

* Product supplied on 2500 piece carrier tape reels.

Pin Configuration

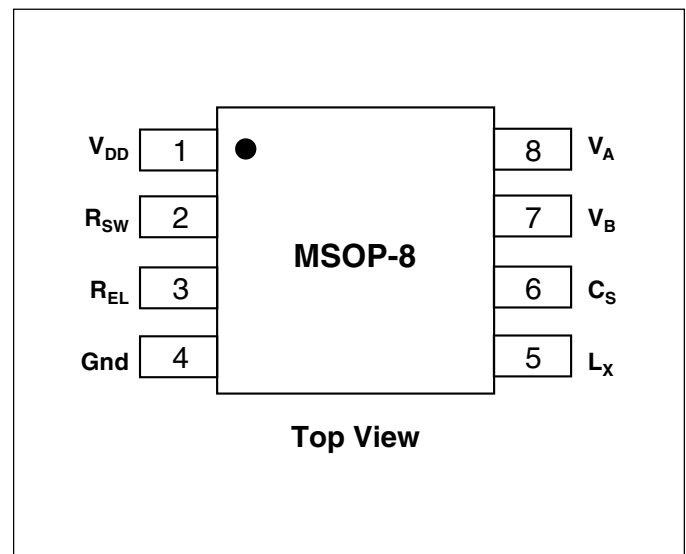

Block Diagram

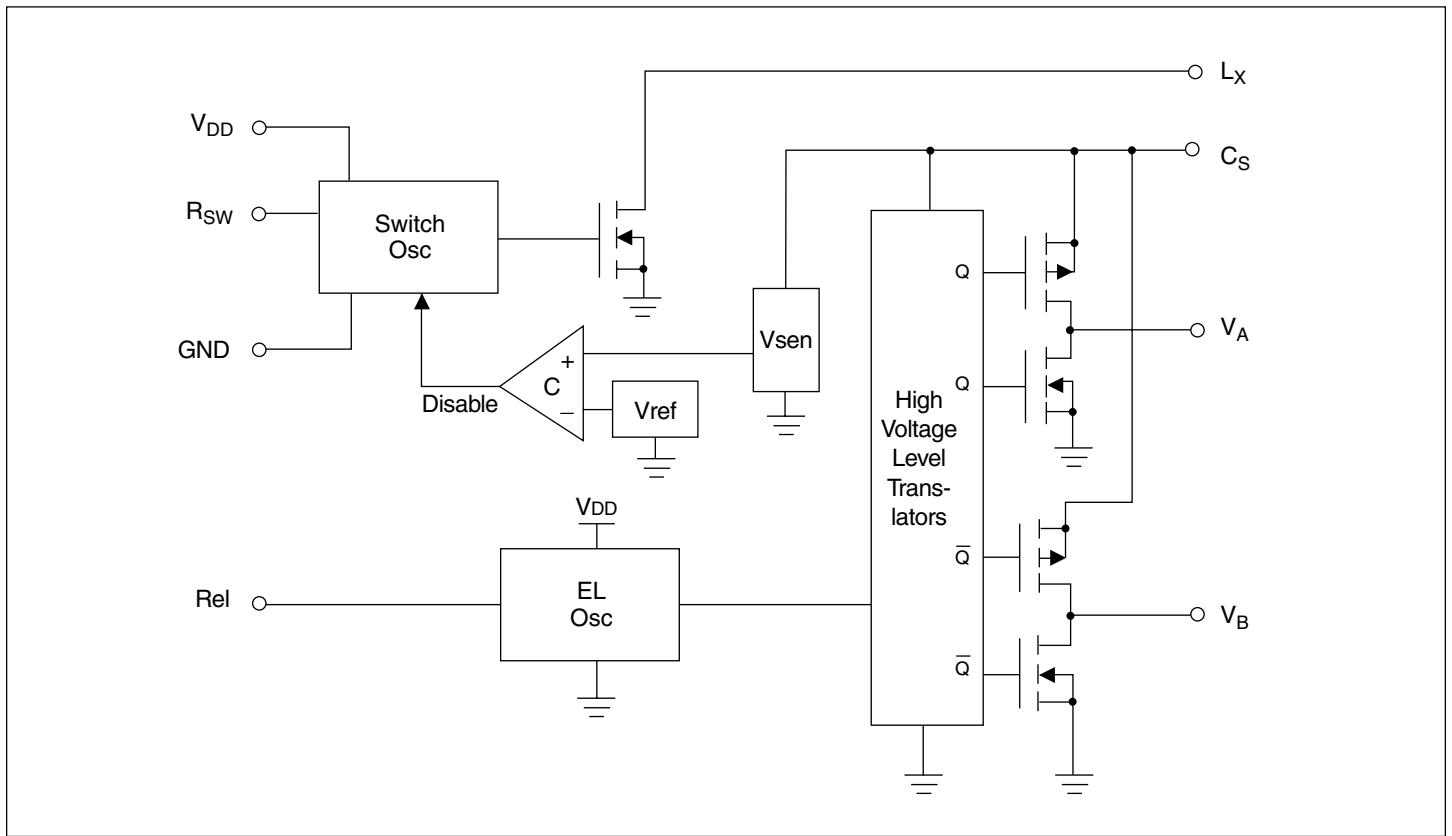
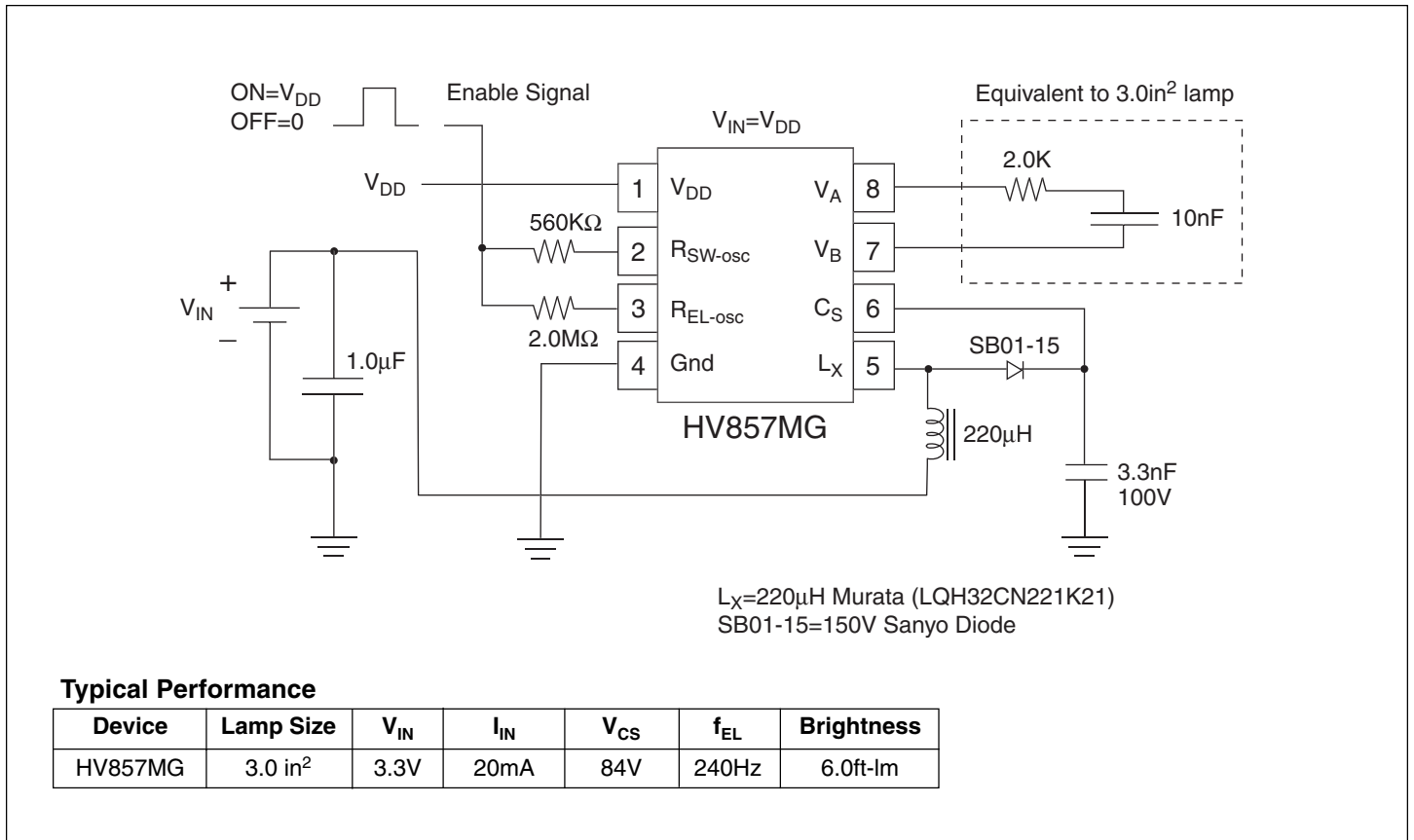
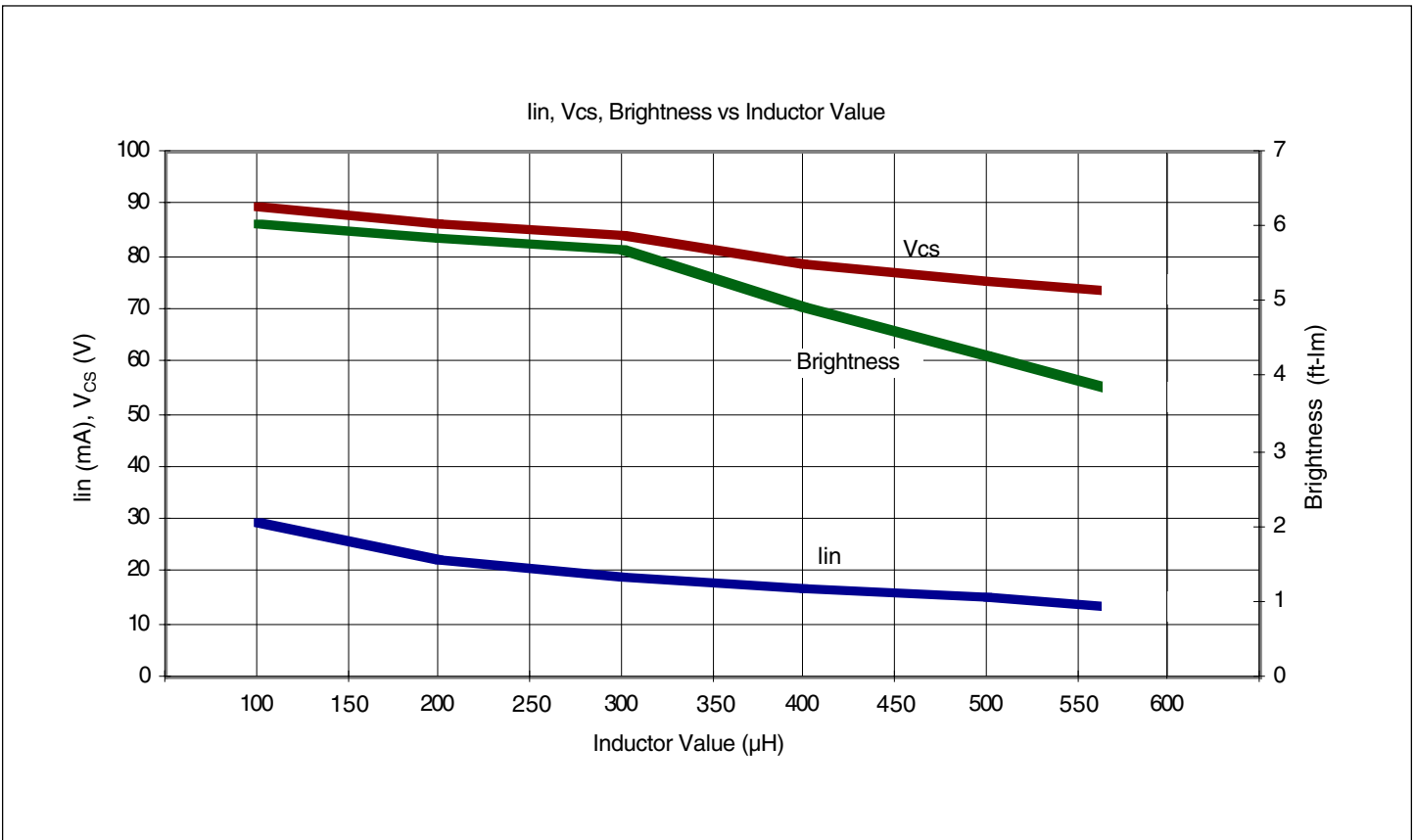
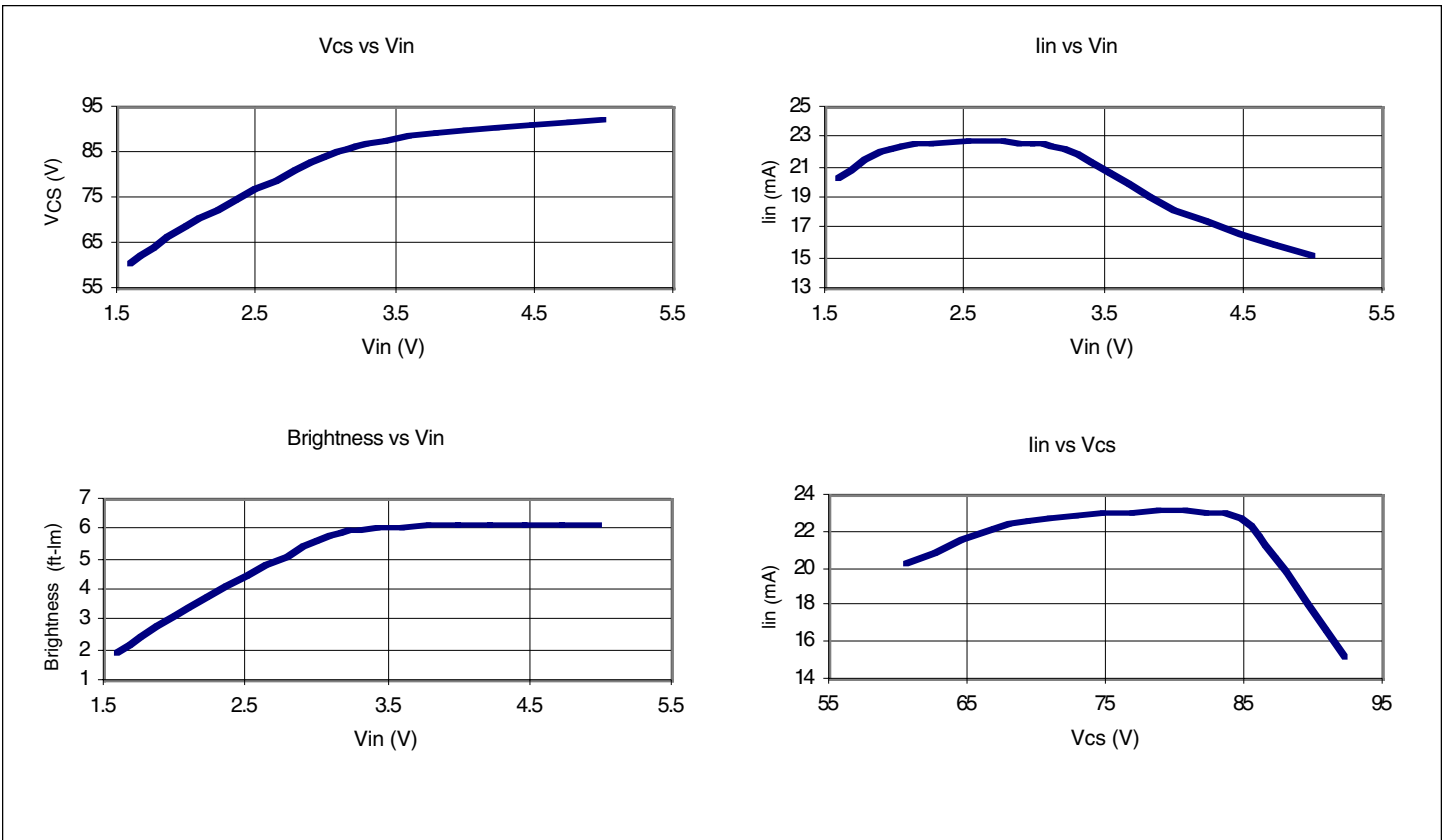

Figure 1: Typical Application/Test Circuit



Typical Performance Curves for Figure 1 (EL Lamp=3.0in², V_{DD}=3.0V)



External Component Description

External Component	Selection Guide Line
Diode	Fast reverse recovery diode, 150V Sanyo SB01-15 or equivalent.
Cs Capacitor	0.003 μ F to 0.1 μ F, 100V capacitor to GND is used to store the energy transferred from the inductor.
R _{EL-osc}	<p>The EL lamp frequency is controlled via an external R_{EL} resistor connected between R_{EL-osc} and V_{DD} of the device. The lamp frequency increases as R_{EL} decreases. As the EL lamp frequency increases, the amount of current drawn from the battery will increase and the output voltage V_{CS} will decrease. The color of the EL lamp is dependent upon its frequency.</p> <p>A 2MΩ resistor would provide lamp frequency of 205 to 275Hz. Decreasing the R_{EL-osc} by a factor of 2 will increase the lamp frequency by a factor of 2.</p>
R _{SW-osc}	The switching frequency of the converter is controlled via an external resistor, R _{SW} between R _{SW-osc} and V _{DD} of the device. The switching frequency increases as R _{SW} decreases. With a given inductor, as the switching frequency increases, the amount of current drawn from the battery will decrease and the output voltage, V _{CS} , will also decrease.
Lx Inductor	<p>The inductor L_x is used to boost the low input voltage by inductive flyback. When the internal switch is on, the inductor is being charged. When the internal switch is off, the charge stored in the inductor will be transferred to the high voltage capacitor C_S. The energy stored in the capacitor is connected to the internal H-bridge and therefore to the EL lamp. In general, smaller value inductors, which can handle more current, are more suitable to drive larger size lamps. As the inductor value decreases, the switching frequency of the inductor (controlled by R_{SW}) should be increased to avoid saturation.</p> <p>220μH Murata (LQH32CN221) inductors with 8.4Ω series DC resistance is typically recommended. For inductors with the same inductance value but with lower series DC resistance, lower R_{SW} value is needed to prevent high current draw and inductor saturation.</p>
Lamp	As the EL lamp size increases, more current will be drawn from the battery to maintain high voltage across the EL lamp. The input power, (V _{IN} x I _{IN}), will also increase. If the input power is greater than the power dissipation of the package (300mW), an external resistor in series with one side of the lamp is recommended to help reduce the package power dissipation.

Split Supply Configuration

The HV857 can also be used for handheld devices operating from a battery where a regulated voltage is available. This is shown in Figure 2. The regulated voltage can be used to run the internal logic of the HV857. The amount of current necessary to run the internal logic is 150µA Max at a V_{DD} of 3.0V. Therefore, the regulated voltage could easily provide the current without being loaded down.

Enable/Disable Configuration

The HV857 can be easily enabled and disabled via a logic control signal on the R_{SW} and R_{EL} resistors as shown in Figure 2 below. The control signal can be from a microprocessor. R_{SW} and R_{EL} are typically very high values. Therefore, only 10's of microamperes will be drawn from the logic signal when it is at a logic high (enable) state. When the microprocessor signal is high the device is enabled and when the signal is low, it is disabled.

Figure 2: Split Supply and Enable/Disable Configuration

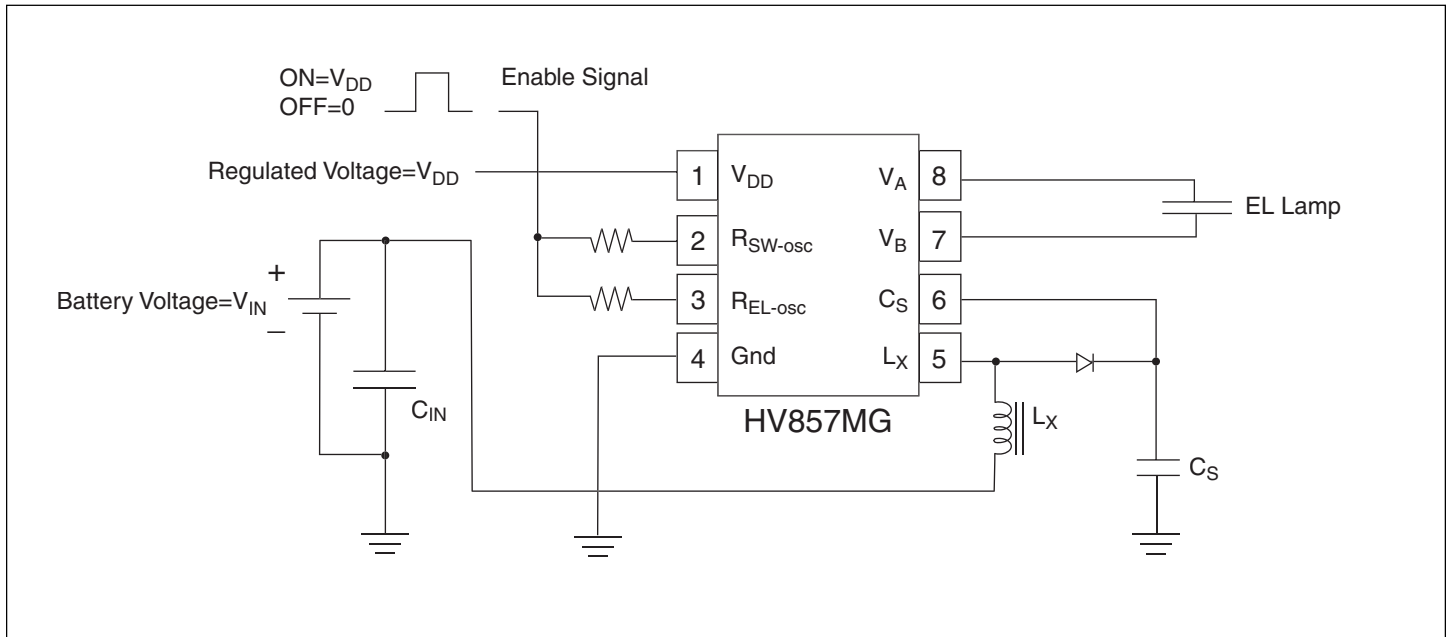

HV857 EL Lamp Driver Circuits for Low Audible Noise or High Brightness Applications

by Roshanak Aflatouni, Applications Engineer

This Application Note describes the method (patent pending) to reduce the audible noise generated by an EL (Electroluminescent) lamp used in mobile phone applications.

This Application Note also provides example circuits as a guideline for applications with different lamp sizes, input voltages, and brightness requirements.

For additional assistance in designing EL driver circuits, please refer to Application Notes AN-H33 (effect of external components on performance of Supertex EL drivers), Lamp Driver Circuits.

When constructing and testing one of the driver circuits listed below, keep in mind that results may differ from those given due to lamp characteristics and component tolerance.

When making component changes for circuit optimization, always remove supply voltages first. After making adjustments, bring up the supply voltage slowly starting from the minimum required device input voltage while monitoring input current. A sharp rise in current usually indicates a saturated inductor. Use a higher current rated inductor, a higher value inductor, or increase conversion frequency by lowering R_{SW-OSC} value.

Figure 1: Typical Application Circuit

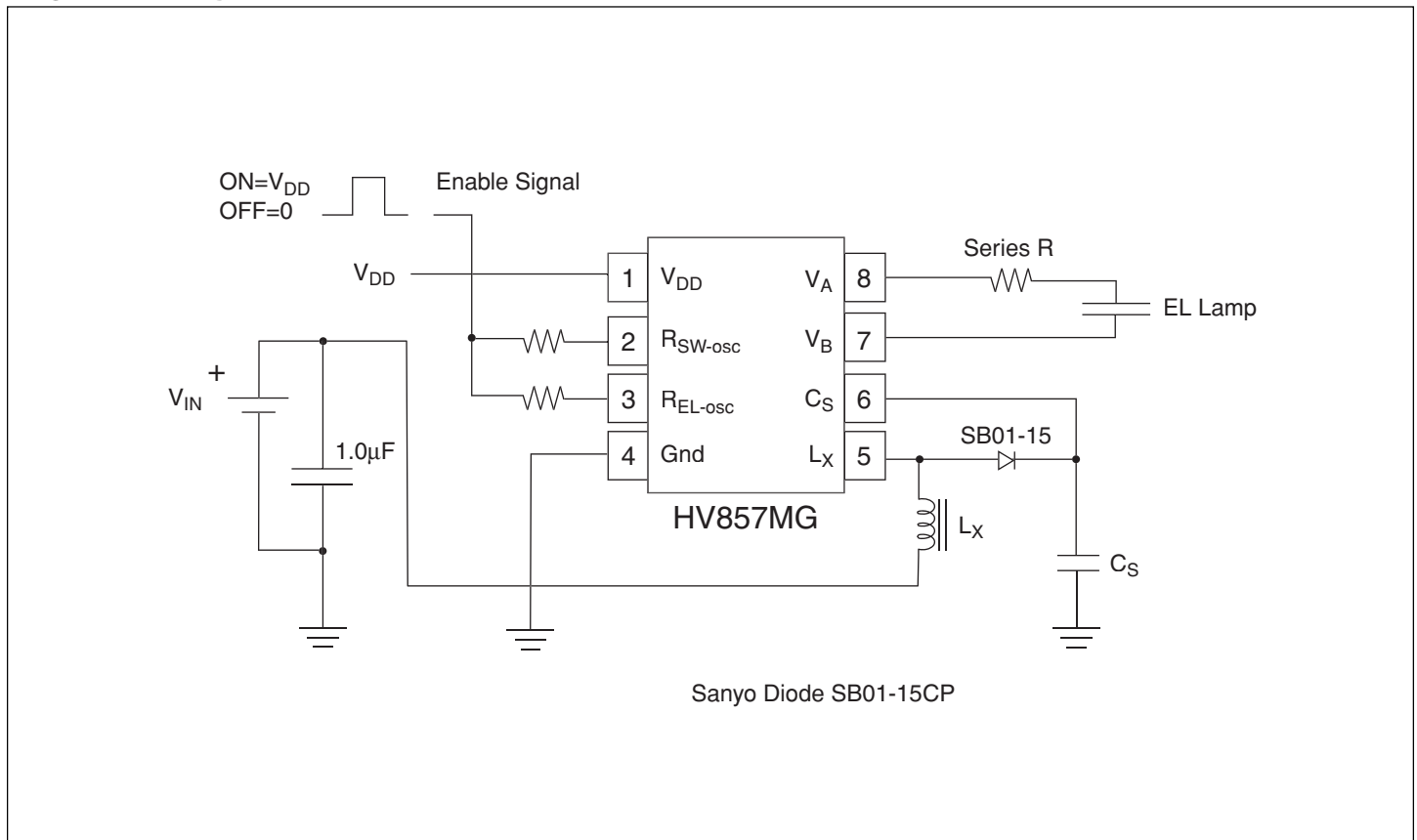

Mobile Phone Circuit for Audible Noise Reduction:¹

The following table provides EL lamp audible noise and brightness for circuits which were designed based on typical EL lamp sizes for Mobile phone applications. See Figure 1, Table 3.

Table 1

Circuit	Lamp Size + Series R	Audible Noise	Lamp Brightness		Supply Voltage		Lx Supply Current	Lamp Frequency
			ft-lm	Cd/m ²	V _{DD}	V _{IN}		
1	2.6in ² + 0K	35.1dBA	8.09	27.7	3.0V	3.0V	20.6mA	250Hz
	2.6in ² + 25K	32.0dBA	6.93	23.7			23.3mA	
	2.6in ² + 50K	29.2dBA	5.00	17.1			23.5mA	
	2.6in ² + 75K	26.7dBA	3.83	13.1			22.6mA	
	2.6in ² + 100K	23.3dBA	2.80	9.56			21.3mA	
2	1.7in ² + 0K	32.0dBA	6.90	23.59	3.0V	3.0V	13.4mA	250Hz
	1.7in ² + 25K	28.3dBA	6.35	21.73			15.5mA	
	1.7in ² + 50K	26.0dBA	5.72	19.55			16.6mA	
	1.7in ² + 75K	24.4dBA	4.85	16.60			16.9mA	
	1.7in ² + 95K	22.9dBA	4.20	14.35			16.5mA	
	1.7in ² + 120K	21.0dBA	3.42	11.69			15.6mA	

Note: 1. All values are nominal.

How to Minimize EL Lamp Audible Noise:

The EL lamp, when lit, generates an audible noise. This is due to EL lamp construction which creates a major problem for applications where the EL lamp can be close to the ear such as cellular phones. The noisiest waveform is a square wave and the quietest waveform has been assumed to be a sine wave.

After extensive research, Supertex has developed a waveform that is quieter than a sine wave. The waveform takes the shape of approximately 2RC time constants for rising and 2RC time constants for falling, where the C is the capacitance of the lamp and R is the external resistor used in series with one side of the lamp. This waveform has been proven to generate less noise than a sine wave.

The audible noise from the EL lamp can be set at a desired level based on the series resistor value used with the lamp. We have chosen two commonly used lamp sizes for the mobile phones to demonstrate the effect of series resistor on the audible noise generated by the EL lamp. It is important to note that use of this resistor will reduce the voltage across the lamp. Reduction of voltage across the lamp will also have another effect on the overall performance of the Supertex EL drivers, age compensation (patent pending). This addresses a very important issue. EL lamp life is an important design concern to mobile phone manufacturers.

As an EL lamp ages, its brightness is reduced and its capacitance is diminished. By using the RC model to reduce the audible noise generated by an EL lamp, the voltage across the lamp will increase as its capacitance diminishes. Hence the increase in voltage will compensate for the reduction of the brightness. As a result, it will extend an EL lamp's half-life (half the original brightness).

Effect of Series Resistor on EL Lamp Audible Noise and Brightness:

Increasing the value of the series resistor with the lamp will reduce the audible noise of an EL lamp as well as its brightness. This is due to the fact that the output voltage across the lamp will be reduced and the output waveform will have rounder edges.

Circuit 1

Lamp Noise vs. Series R (2.6in² EL Lamp)

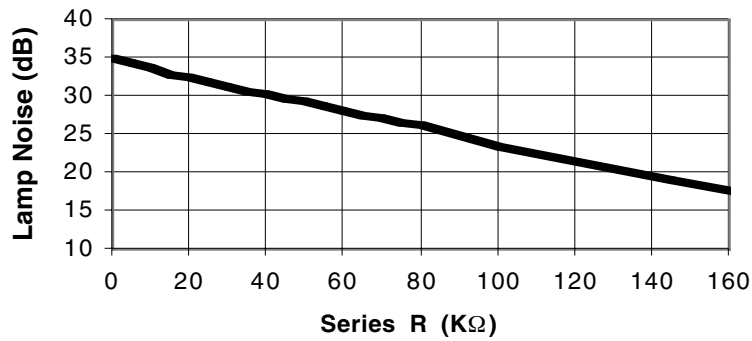

Brightness vs. Series R (2.6in² EL Lamp)

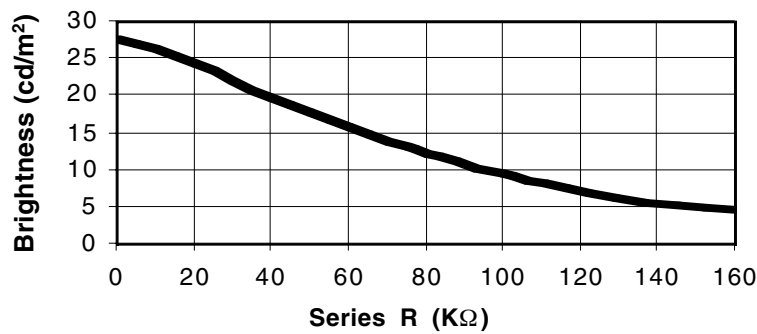

Circuit 2

Lamp Noise vs. Series R (1.7in² EL Lamp)

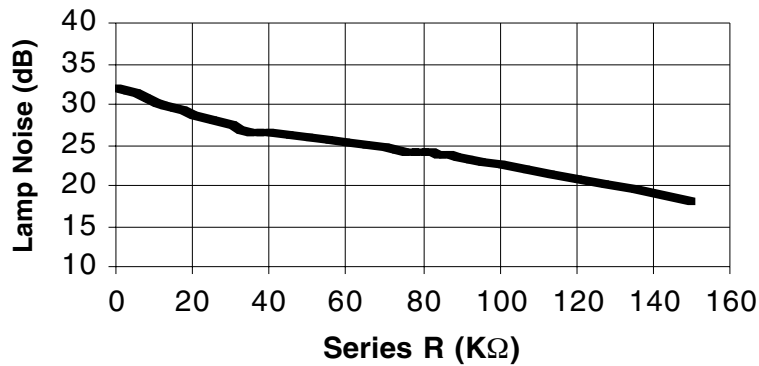

Brightness vs. Series R (1.7in² EL Lamp)

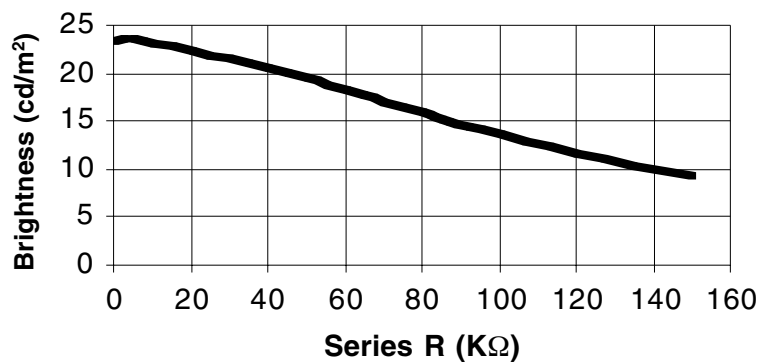

Typical HV857 Output waveform Before and After Noise Reduction:

The following are actual scope pictures, which show the differential output waveform across the lamp, audible noise, and lamp light output for circuits 1 and 2.

Circuit 1

Series R=0Ω

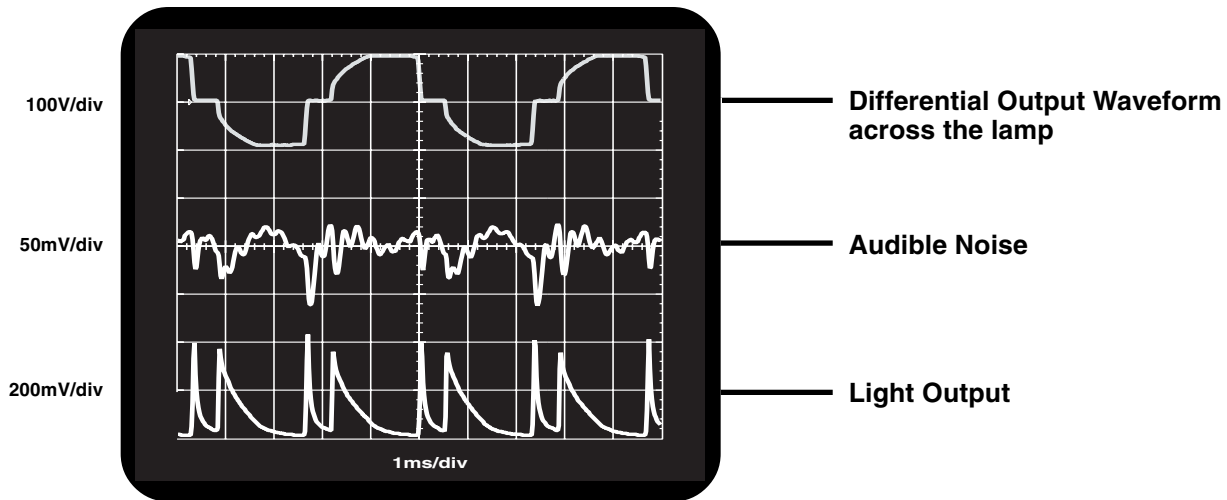

Series R=65KΩ

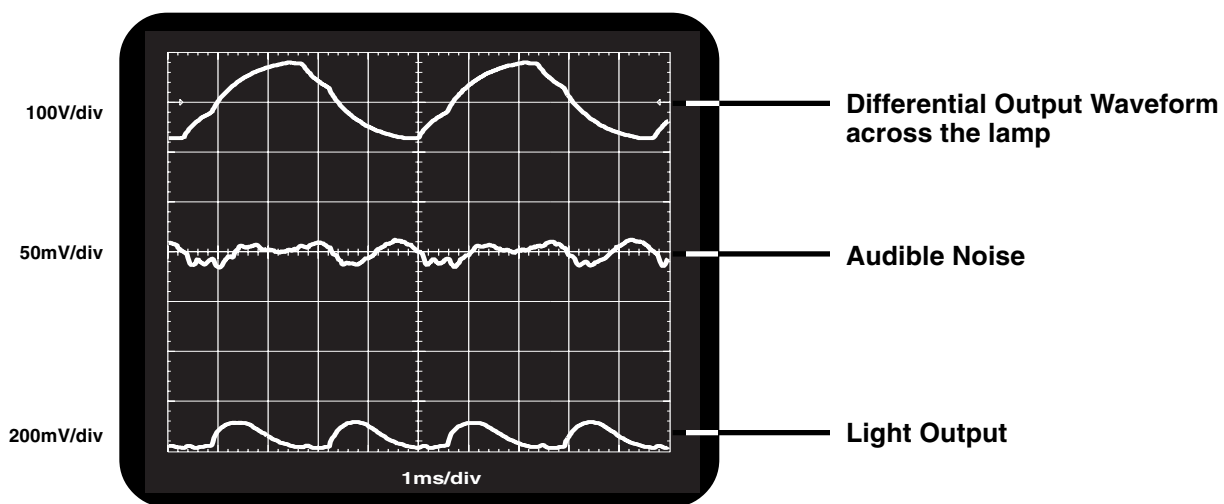

Circuit 2

Series R=0Ω

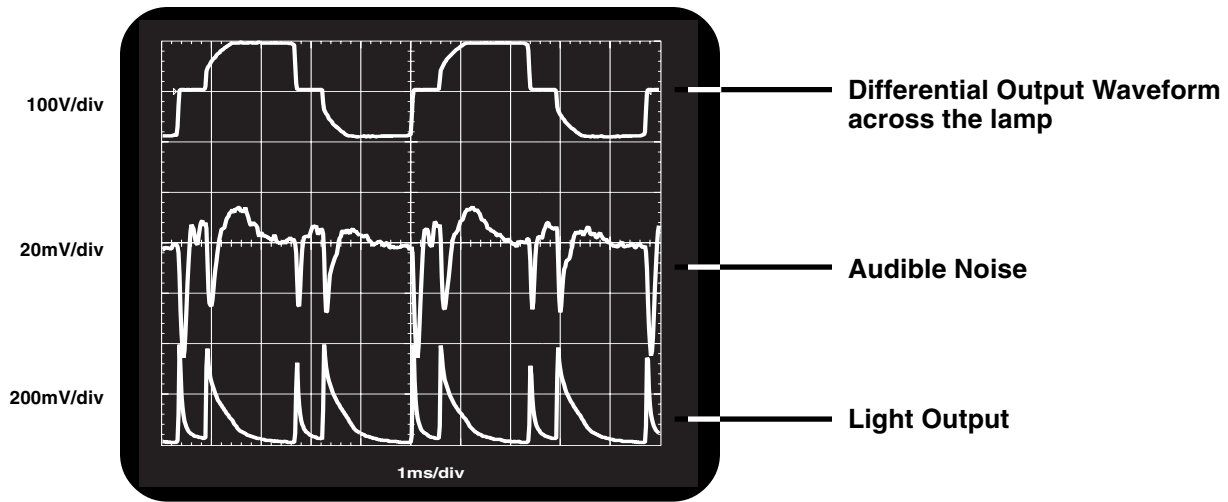

Series R=55KΩ

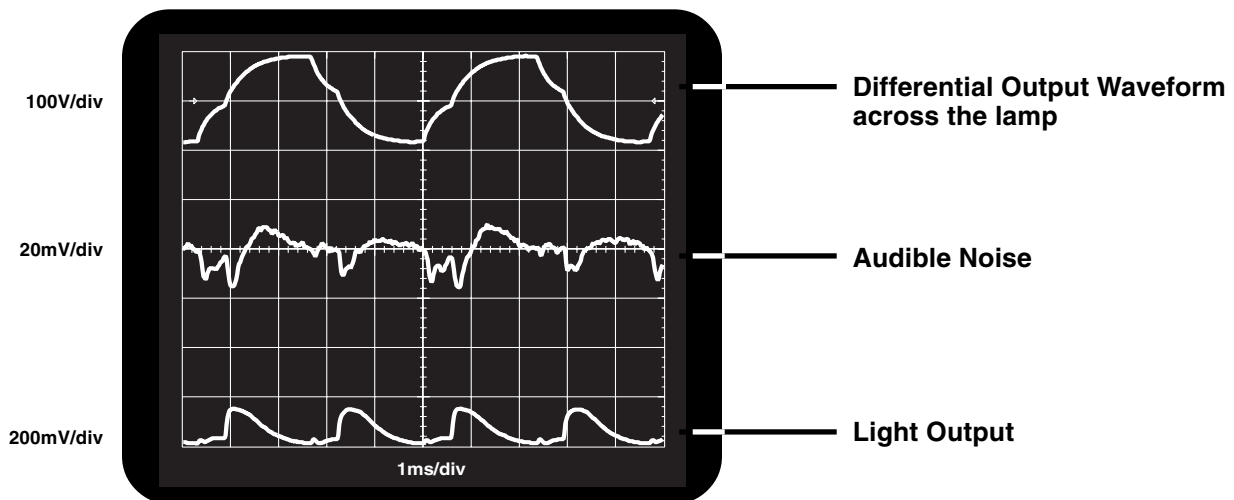

Audible Noise Measurement Setup:

The following setup was used to collect EL lamp audible noise data. An Oscilloscope/Spectrum analyzer was used to observe the differential output waveform, audible noise level (in mV), and light output (in mV) of the EL lamp. The EL lamp is placed in the anechoic chamber and a condenser microphone is placed 10mm away from the surface of the EL lamp.

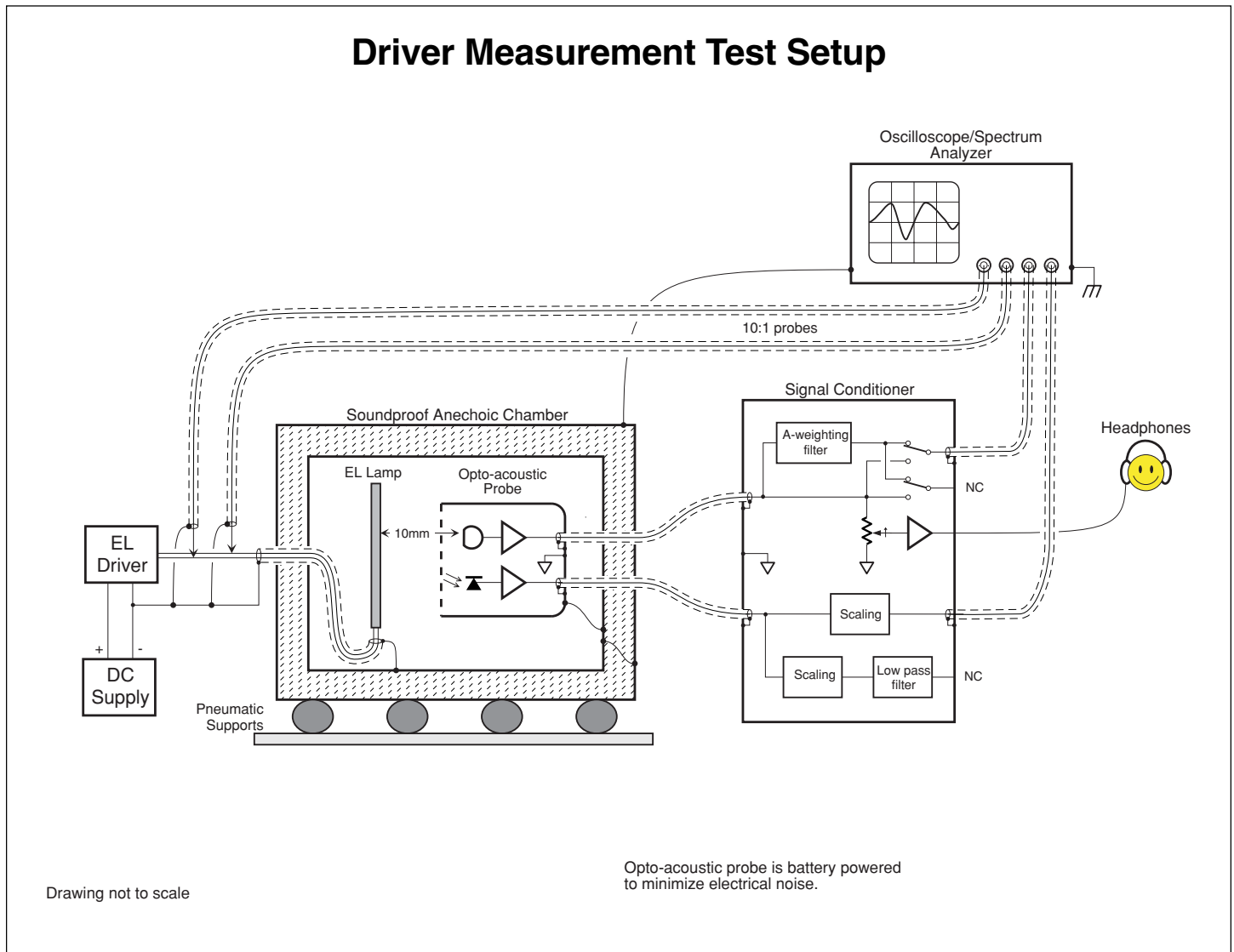

Circuit Selector Guide for Non Audible Noise Sensitive Applications:¹ (Handheld products, PDAs, GPS, 2-way pagers, MP3)

No series resistor is used for the following circuits ($R=0\Omega$). Also see Figure 1 and Table 3.

Table 2

Circuit	Lamp Size	Lamp Brightness		Supply Voltage		Lx Supply Current	Output Voltage	Lamp Frequency
		ft-lm	Cd/m ²	V _{DD}	V _{IN}			
3	1.3in ²	9.38	32.10	3.3V	3.3V	12.9mA	180Vp-p	357Hz
4	1.7in ²	4.44 4.48	15.2 15.31	3.0V	3.2V 4.2V	7.4mA 5.7mA	182Vp-p 186Vp-p	160Hz
5	1.7in ²	12.0 13.2	41.6 45.3	3.0V	3.2V 4.2V	23.7mA 20.9mA	168Vp-p 178Vp-p	475Hz
6	0.93in ²	7.74	26.51	3.0V	3.0V	8.3mA	175Vp-p	250Hz
7	3.1in ²	7.84	26.87	5.0V	5.0V	17.9mA	184Vp-p	250Hz
8	4.0in ²	7.50	25.7	3.0V	3.0V	25.8mA	160Vp-p	250Hz
9	5.2in ²	4.77	16.34	3.3V	3.3V	21.2mA	168Vp-p	160Hz

Note: 1. All values are nominal. Lamp brightness and current draw can vary by type and manufacturer.

External components used for Circuits 1 to 9:

The following table provides the value for external components used in Figure 1. The manufacturer and part number for the inductor is also provided. If other value inductors are used, the circuit will need to be reoptimized.

Table 3

Circuit	Lx Inductor		R _{sw-osc}	R _{EL-osc}	C _s Capacitor	
	Value	Manufacturer, Part. No.			Value	Type
1	220 μ H	MuRata, LQH32CN221K21	560K	2.0M	3.3nF	NPO
2	220 μ H	MuRata LQH32CN221K21	560K	2.0M	3.3nF	NPO
3	220 μ H	MuRata, LQH32CN221K21	560K	1.5M	3.3nF	NPO
4	220 μ H	MuRata, LQH32CN221K21	330K	3.3M	3.3nF	NPO
5	220 μ H	MuRata, LQH32CN221K21	560K	1.0M	3.3nF	NPO
6	220 μ H	MuRata, LQH32CN221K21	560K	2.0M	3.3nF	NPO
7	220 μ H	MuRata, LQH32CN221K21	560K	2.0M	3.3nF	NPO
8	220 μ H	MuRata, LQH43MN221K01	560K	2.0M	3.3nF	NPO
9	220 μ H	MuRata, LQH43MN221K01	560K	3.3M	3.3nF	NPO

L_x Inductor Selection:

Different inductor values and/or from different manufacturers can be used in place of what is shown. However, the circuit will need to be reoptimized by changing the R_{SW-OSC} value. Smaller R_{SW-OSC} value needs to be used for inductors with lower series resistance. Lower amount of current will be drawn when using larger value inductors. But, for the same R_{SW-OSC} value, a lower amount of energy will be transferred due to the higher series resistance of a larger value inductor. Hence, when larger value inductors with higher series resistance are used, the R_{SW-OSC} value needs to be increased. It is very important to make a note of the saturation current of the inductor. If the saturation current of the inductor is lower than what the circuit/application requires, the inductor and/or IC will be damaged.

C_s Capacitor Selection:

Different C_s Capacitor types and value can be used in place of what is shown in circuits 1 to 9. However, the use of a different C_s Capacitor type will generate audible noise due to the piezo electric effect of materials used for their structure (such as X7R and 5YU capacitors).

A different value capacitor can be used. A larger value C_s Capacitor (10nF) is recommended to be used for larger EL lamps and/or larger input voltage range. A smaller value C_s Capacitor can be used as long as the over all efficiency of the circuit is not decreased. When using a smaller value C_s Capacitor, the circuit will need to be reoptimized by using a smaller R_{SW-OSC} value.