

3V, DUAL TRIP POINT TEMPERATURE SENSOR

FEATURES

- Integrated Temp Sensor and Detector Operate from a Supply Voltage as Low as 2.7V
- Replaces Mechanical Thermostats and Switches
- On-Chip Temperature Sense
- 8-Pin DIP or SOIC for Direct PCB Mounting
- 2 User-Programmable Temperature Set Points
- 2 Independent Temperature Limit Outputs
- Heat/Cool Regulate Output

APPLICATIONS

- CPU Thermal Management
- System Over-or Under-Temperature Shutdown
- Advanced Thermal Warning
- Fan Speed Control Circuits
- Accurate Appliance Temperature Sensing
- Environmental Control

GENERAL DESCRIPTION

The TC623 is a 3V solid-state, programmable temperature sensor designed for use in thermal management applications. It features dual thermal interrupt outputs (LOW LIMIT and HIGH LIMIT) each of which program with a single external resistor. The HIGH LIMIT and LOW LIMIT outputs are driven active (high) when measured temperature equals the user-programmed limits. The CONTROL output is driven active (high) when temperature equals the HIGH LIMIT setpoint, and turned off when temperature falls below the LOW LIMIT setpoint. The CONTROL output can be used to provide simple ON/OFF control to a cooling fan if so desired.

Low voltage operation, easy setpoint programming, small size and low cost make the TC623 an ideal choice for many thermal management applications.

ORDERING INFORMATION

Part No.	Package	Temperature Range
TC623CCOA	8-Pin SOIC	0°C to +70°C
TC623CCPA	8-Pin Plastic DIP	0°C to +70°C
TC623CEOA	8-Pin SOIC	-40°C to +85°C
TC623CEPA	8-Pin Plastic DIP	-40°C to +85°C
TC623CVOA	8-Pin SOIC	-40°C to +125°C

NOTE: Latch Q Output, ("C" Option), is a Standard Device. Contact Factory for Latch Q Output, ("H" Option).

FUNCTIONAL BLOCK DIAGRAM

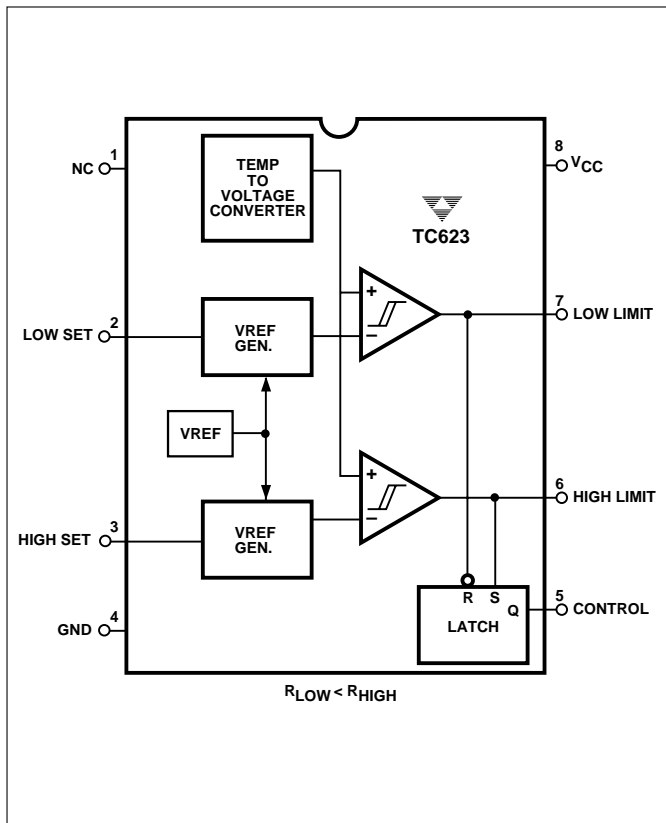

PIN CONFIGURATION (DIP and SOIC)

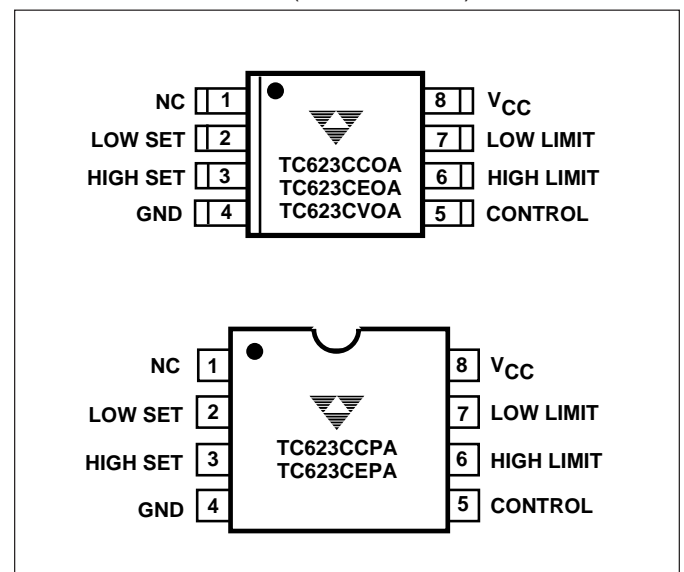

3V, DUAL TRIP POINT TEMPERATURE SENSOR

TC623

ABSOLUTE MAXIMUM RATINGS*

Package Power Dissipation ($T_A \leq 70^\circ\text{C}$)	
Plastic DIP	730mW
SOIC	470mW
Derating Factors	
Plastic DIP	8mW/ $^\circ\text{C}$
SOIC	6mW/ $^\circ\text{C}$
Supply Voltage	5.5V
Input Voltage Any Input	(GND - 0.3V) to ($V_{DD} + 0.3V$)
Operating Temperature	
V Version	- 40 $^\circ\text{C}$ to +125 $^\circ\text{C}$
E Version	- 40 $^\circ\text{C}$ to +85 $^\circ\text{C}$
C Version	0 $^\circ\text{C}$ to +70 $^\circ\text{C}$

Maximum Chip Temperature	+150 $^\circ\text{C}$
Storage Temperature	- 65 $^\circ\text{C}$ to +150 $^\circ\text{C}$
Lead Temperature (Soldering, 10 sec)	+300 $^\circ\text{C}$

*Static-sensitive device. Unused devices must be stored in conductive material. Protect devices from static discharge and static fields. Stresses above those listed under "Absolute Maximum Ratings" may cause permanent damage to the device. These are stress ratings only and functional operation of the device at these or any other conditions above those indicated in the operation sections of the specifications is not implied. Exposure to absolute maximum rating conditions for extended periods may affect device reliability.

ELECTRICAL CHARACTERISTICS

Over Operating Temperature Range) $V_{DD} = 2.7V$ to $4.5V$, unless otherwise specified.

Parameter	Conditions	Min	Typ*	Max	Unit
Supply Voltage Range		2.7	—	4.5	V
Supply Current	$2.7V \leq V_{DD} \leq 4.5V$	—	150	250	μA
Absolute Accuracy	T = Programmed Temperature	T - 3	T \pm 1	T + 3	$^\circ\text{C}$
V_{OH}	$I_{OH} = 250\mu\text{A}$	$0.9 \times V_{DD}$	—	—	V
	$I_{OH} = 500\mu\text{A}$	$0.8 \times V_{DD}$	—	—	V
V_{OL}	$I_{OL} = 500\mu\text{A}$	—	—	$0.1 \times V_{DD}$	V
	$I_{OL} = 1\text{mA}$	—	—	$0.2 \times V_{DD}$	V
Hysteresis	Falling Temperature	—	—	- 2	$^\circ\text{C}$

* Measured at 25 $^\circ\text{C}$

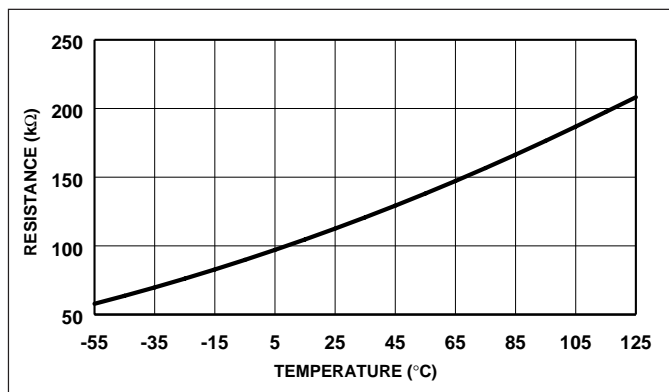

Figure 1. TC623 Sense Resistors vs. Trip Temperature

DETAILED DESCRIPTION

TC623 Operation

The TC623 consists of a positive temperature coefficient (PTC) temperature sensor and dual threshold detector. Temperature set point programming is easily accomplished with external programming resistors from the HIGH SET and LOW SET inputs to V_{CC} . The HIGH LIMIT and LOW LIMIT outputs remain inactive (low) as long as the measured temperature is below setpoint values. As temperature in-

creases, the LOW LIMIT is driven high when temperature equals the LOW LIMIT setpoint ($\pm 3^\circ\text{C}$). If temperature continues to climb, the HIGH LIMIT output is driven high when temperature equals the HIGH LIMIT setpoint ($\pm 3^\circ\text{C}$). Figure 1 shows the relationship between the sense resistance values and trip point temperature.

The CONTROL output is driven high when the HIGH LIMIT output goes high, and is reset low when the LOW LIMIT output goes low. This output provides the logic for simple ON/OFF fan control. Figure 2 shows overall TC623 operation.

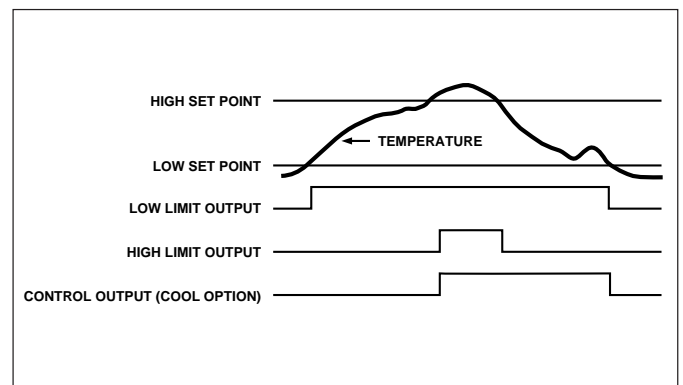

Figure 2. TC623 Temperature vs. Output

3V, DUAL TRIP POINT TEMPERATURE SENSOR

To prevent output "chattering" when measured temperature is at (or near) the programmed trip point values, the LOW SET and HIGH SET inputs each have a built-in hysteresis of -2°C max. As a result, the HIGH LIMIT and LOW LIMIT outputs remain active until the measured temperature falls a maximum of 2°C below the programmed HIGH SET and LOW SET thresholds as shown in Figure 3. The *programmed setting* threshold of Figure 3 is user-programmed temperature trip points of either the LOW SET or HIGH SET inputs. The LOW LIMIT or HIGH LIMIT output is driven active when temperature equals the programmed setpoint value (to within 3°C). The output *remains* active until the temperature falls an additional 2°C below the setpoint due to hysteresis.

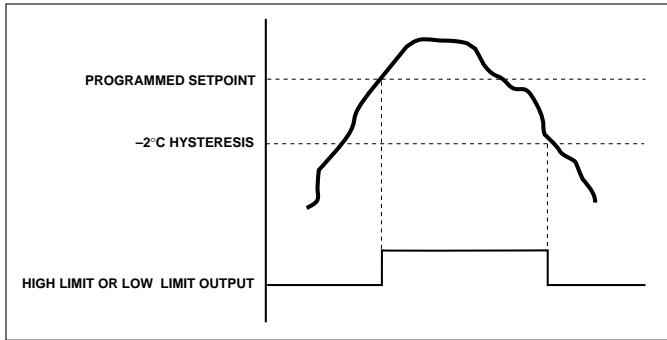

Figure 3. High Set and Low Set Thresholds

APPLICATIONS

Mounting

If the TC623 is used to measure the temperature of another device, it is important that the top surface of the TC623 package be in intimate contact with the measured device. Good thermal conductivity and no air space is critical to accurate temperature measurement in applications of this type.

Trip Point Programming

The resistance values required for the HIGH SET and LOW SET inputs are calculated using the formula below:

$$R_{\text{TRIP}} = 0.5997 \times T^{2.1312}$$

Where R_{trip} = Programming resistor value in Ohms
 T = Desired trip temperature in degrees Kelvin.

For example, to program a trip point of 50°C , the programming resistor is:

$$R_{\text{TRIP}} = 0.5997 \times (50 + 273.15)^{2.1312} = 133,652 \Omega$$