

# TCN4040

## PRECISION MICROPOWER SHUNT VOLTAGE REFERENCE

### FEATURES

- Small Packages ..... SOT-23B-3, TO-92, and SO-8
- Output Capacitor Not Required
- Handles Capacitive Loads
- Fixed Reverse Breakdown Voltage of 2.5V
- Low Output Noise
- Wide Operating Current Range (60µA to 15mA)
- - 40°C to + 85°C Operating Temperature Range

### APPLICATIONS

- Portable, Battery-Powered Equipment
- Data Acquisition Systems
- Instrumentation
- Process Control
- Energy Management
- Product Testing
- Automotive
- Precision Audio Components

### GENERAL DESCRIPTION

For applications in tight quarters, the TCN4040 precision voltage reference is available in a space-saving 3mm x 1.3mm SOT-23B-3 surface mount package. The TCN4040 eliminates the need for an external stabilizing capacitor while maintaining stability with any capacitive load. The minimum operating current is 60µA. The maximum operating current is 15mA.

To ensure that the prime parts have an accuracy of better than ±0.5% (C grade) at 25°C, the TCN4040 uses fuse and zener-zap reverse breakdown voltage trim during wafer sort. Low dynamic impedance and bandgap reference temperature drift curvature correction maintain stable reverse breakdown voltage accuracy over a wide range of operating temperatures (- 40°C to + 85°C) and currents from (60µA to 15mA).

The TCN4040 also is available in both adjustable and 1.2V versions.

### ORDERING INFORMATION

Part No.	Output Voltage (V)	Package	Voltage Tolerance Temp. Coefficient Grade
TCN4040C-2.5ENB	2.5	SOT-23B-3*	±0.5%, 100ppm/°C Max (C Grade)
TCN4040C-2.5EOA	2.5	8-Pin SOIC	±0.5%, 100ppm/°C Max (C Grade)
TCN4040C-2.5EZB	2.5	TO-92	±0.5%, 100ppm/°C Max (C Grade)
TCN4040D-2.5EOA	2.5	8-Pin SOIC	±1.0%, 150ppm/°C Max (D Grade)
TCN4040D-2.5ENB	2.5	SOT-23B-3*	±1.0%, 150ppm/°C Max (D Grade)
TCN4040D-2.5EZB	2.5	TO-92	±1.0%, 150ppm/°C Max (D Grade)
TCN4040E-2.5ENB	2.5	SOT-23B-3*	±2.0%, 150ppm/°C Max (E Grade)
TCN4040E-2.5EZB	2.5	TO-92	±2.0%, 150ppm/°C Max (E Grade)

NOTE: \*SOT-23B-3 is equivalent to the JEDEC (TO-236)

### PIN CONFIGURATION

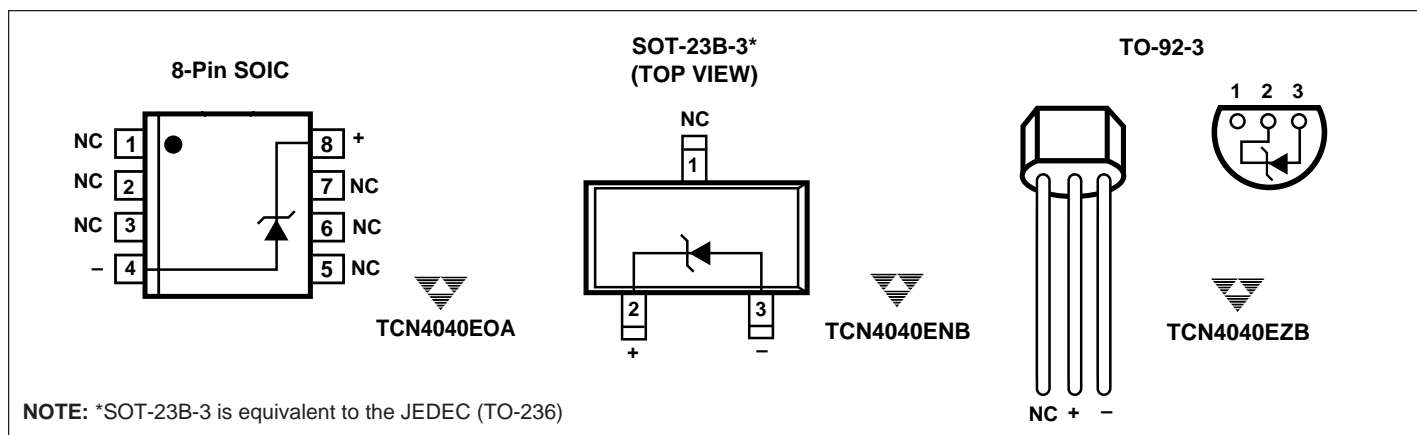

TCN4040

**ABSOLUTE MAXIMUM RATINGS\*** (Note 1)

Reverse Current .....	20mA
Forward Current .....	10mA
Power Dissipation (T <sub>A</sub> = 25°C) (Note 2)	
SOT-23B-3 Package .....	230mW
TO-92 Package .....	440mW
SO-8 Package .....	470mW
Storage Temperature .....	- 65°C to + 150°C
Lead Temperature (Soldering, 10 seconds)	
EOA .....	+260°C
ENB .....	+300°C
EZB .....	+300°C

ESD Susceptibility

Human Body Model (Note 3) .....	2kV
Machine Model (Note 3) .....	.200V

\*Functional operation above the absolute maximum stress rating is not implied.

**OPERATING RATINGS (NOTES 1 AND 2)**

Temperature Range	
(T <sub>MIN</sub> ≤ T <sub>A</sub> ≤ T <sub>MAX</sub> ) .....	- 40°C ≤ T <sub>A</sub> ≤ +85°C
Reverse Current	
TCN4040-2.5 .....	.60μA to 15mA

- NOTES:**
1. Absolute Maximum Ratings indicate limits beyond which damage to the device may occur. Operating Ratings indicate conditions for which the device is functional, but do not guarantee specific performance limits. For guaranteed specifications and test conditions, see *Electrical Characteristics*. The guaranteed specifications apply only for the test conditions listed. Some performance characteristics may degrade when the device is not operated under the listed test conditions.
  2. The maximum power dissipation must be derated at elevated temperatures and is dictated by T<sub>JMAX</sub> (maximum junction temperature), θ<sub>JA</sub> (junction to ambient thermal resistance), and T<sub>A</sub> (ambient temperature). The maximum allowable power dissipation at any temperature is PD<sub>MAX</sub> = (T<sub>JMAX</sub> - T<sub>A</sub>) / θ<sub>JA</sub> or the number given in Absolute Maximum Ratings, whichever is lower. For the TCN4040, T<sub>JMAX</sub> = 125°C, and the typical thermal resistance (θ<sub>JA</sub>), when board mounted, is 185°C/W for the M package, 326°C/W for the SOT-23B-3 package, and 180°C/W with 0.4" lead length and 170°C/W with 0.125" lead length for the TO-92-3 package.
  3. The human body model is a 100pF capacitor discharged through a 1.5kΩ resistor into each pin. The machine model is a 200pF capacitor discharged directly into each pin.

**ELECTRICAL CHARACTERISTICS:** **Boldface** type specifications apply for T<sub>A</sub> = T<sub>J</sub> = T<sub>MIN</sub> to T<sub>MAX</sub>. All other specifications; T<sub>A</sub> = T<sub>J</sub> = 25°C.

Symbol	Parameter	Test Conditions	TCN4040CEOA TCN4040CENB TCN4040CEZB			TCN4040DEOA TCN4040DENB TCN4040DEZB			TCN4040EENB TCN4040EEZB			Unit
			Min	Typ	Max	Min	Typ	Max	Min	Typ	Max	
V <sub>R</sub>	Reverse Breakdown Voltage	I <sub>R</sub> = 100μA Notes 4, 5	—	2.500	—	—	2.500	—	—	2.500	—	V
	Reverse Breakdown Voltage Tolerance	I <sub>R</sub> = 100μA Notes 4, 5, 6	—		±12 ±29	—		±25 ±49	—		±50 ±74	mV
I <sub>RMIN</sub>	Minimum Operating Current	Notes 4, 5	—	45	60 65	—	45	65 70	—	45	65 70	μA
ΔV <sub>R</sub> /ΔT	Average Reverse Breakdown Voltage Temperature Coefficient	I <sub>R</sub> = 10mA I <sub>R</sub> = 1mA I <sub>R</sub> = 100μA Notes 4, 5	—	±20 ±15 ±15	±100	—	±20 ±15 ±15	±150	—	±20 ±15 ±15	±150	ppm/°C
ΔV <sub>R</sub> /ΔI <sub>R</sub>	Reverse Breakdown Voltage Change with Operating Current Change	I <sub>RMIN</sub> ≤ I <sub>R</sub> ≤ 1mA Notes 4, 5	—	0.4	0.8 1.0	—	0.4	1.0 1.2	—	0.4	1.0 1.2	mV
		1mA ≤ I <sub>R</sub> ≤ 12mA	—	2.3	6.0 8.0	—	2.3	8.0 10.0	—	2.3	8.0 10.0	mV
Z <sub>R</sub>	Reverse Dynamic Impedance	I <sub>R</sub> = 1mA, f = 120Hz, I <sub>AC</sub> = 0.1 I <sub>R</sub> Notes 4, 5	—	0.3	0.9	—	0.3	1.1	—	0.3	1.1	Ω

**TCN4040**

**ELECTRICAL CHARACTERISTICS (Cont.):** Boldface type specifications apply for  $T_A = T_J = T_{MIN}$  to  $T_{MAX}$ . All other specifications;  $T_A = T_J = 25^\circ\text{C}$ .

Symbol	Parameter	Test Conditions	TCN4040CEOA TCN4040CENB TCN4040CEZB			TCN4040DEOA TCN4040DENB TCN4040DEZB			TCN4040EENB TCN4040EEZB			Unit
			Min	Typ	Max	Min	Typ	Max	Min	Typ	Max	
$e_N$	Wideband Noise	$I_R = 100\mu\text{A}$ , $10\text{Hz} \leq f \leq 10\text{kHz}$ Notes 4, 5	—	35	—	—	35	—	—	35	—	$\mu\text{V/msec}$
$\Delta V_R$	Reverse Breakdown Voltage Long Term Stability	$t = 1000\text{hrs}$ $T = 25^\circ\text{C} \pm 0.1^\circ\text{C}$ $I_R = 100\mu\text{A}$ Notes 4, 5	—	120	—	—	120	—	—	120	—	$\text{ppm}/^\circ\text{C}$

- NOTES:**
- Typicals are at  $T_J = 25^\circ\text{C}$  and represent most likely parametric norm.
  - Limits are 100% production tested at  $25^\circ\text{C}$ .
  - The boldface (over-temperature) limit for Reverse Breakdown Voltage Tolerance is defined as the room temperature Reverse Breakdown Voltage Tolerance  $\pm[(\Delta V_R/\Delta T)(65^\circ\text{C})(V_R)]$ .  $\Delta V_R/\Delta T$  is the  $V_R$  temperature coefficient,  $65^\circ\text{C}$  is the temperature range from  $-40^\circ\text{C}$  to the reference point of  $25^\circ\text{C}$ , and  $V_R$  is the reverse breakdown voltage. The total over-temperature tolerance for the different grades is shown below:  
 C-grade:  $\pm 1.15\% = \pm 0.5\% \pm 100\text{ppm}/^\circ\text{C} \times 65^\circ\text{C}$   
 D-grade:  $\pm 1.98\% = \pm 1.0\% \pm 150\text{ppm}/^\circ\text{C} \times 65^\circ\text{C}$   
 E-grade:  $\pm 2.98\% = \pm 2.0\% \pm 150\text{ppm}/^\circ\text{C} \times 65^\circ\text{C}$

**PIN DESCRIPTION**

Pin No. (SOT-23B-3)	Pin No. TO-92	Pin No. 8-Pin SOIC	Symbol	Description
1	1	1	NC	No connection
		2	NC	No connection
		3	NC	No connection
2	2		+	Positive terminal
3	3		-	Negative terminal
		4	-	Negative terminal
		5	NC	No connection
		6	NC	No connection
		7	NC	No connection
		8	+	Positive terminal

## TCN4040

## APPLICATIONS INFORMATION

Available in a space saving SOT-23B-3 surface mount package, the TCN4040 is a precision micro-power curvature-corrected bandgap shunt voltage reference. The TCN4040 is designed for stable operation without an external capacitor connected between the “+” pin and the “-” pin. The TCN4040 also remains stable, however, if a bypass capacitor is used. The minimum operating current increase is 60mA and the maximum operating current is 15mA.

The TCN4040, in the SOT-23B-3 package has a parasitic Schottky diode between pin 3 (-) and pin 1. (Die attach interface contact). Therefore, pin 1 of the SOT-23B-3 package must be left floating or connected to pin 3.

In a conventional shunt regulator application, an external series resistor ( $R_S$ ) is connected between the supply voltage and the TCN4040 (Figure 1).  $R_S$  determines the current that flows through the load ( $I_L$ ) and the TCN4040 ( $I_Q$ ). Even when the supply voltage is at its minimum, and the load current is at its maximum value,  $R_S$  should be small enough to supply at least the minimum acceptable  $I_Q$  to the TCN4040 since load current and supply voltage may vary. Conversely, when the supply voltage is at its maximum and  $I_L$  is at its minimum,  $R_S$  should be large enough that the current flowing through the TCN4040 is less than 15mA.

$R_S$  is determined by the supply voltage, ( $V_S$ ), the load and operating current, ( $I_L$  and  $I_Q$ ), and the TCN4040's reverse breakdown voltage,  $V_R$ .

$$R_S = \frac{V_S - V_R}{I_L + I_Q}$$

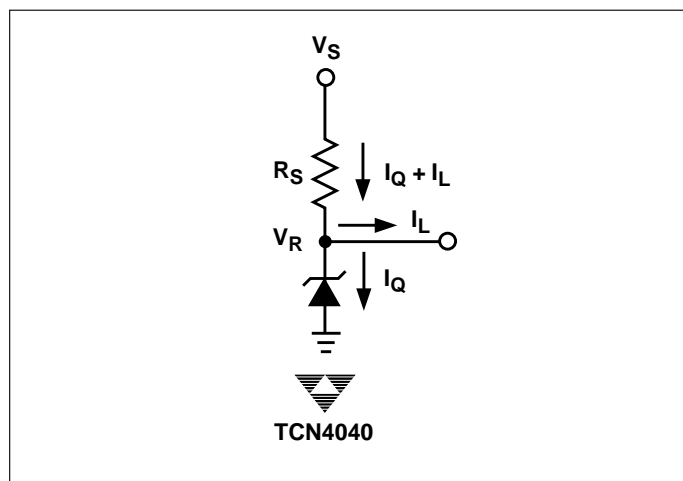

Figure 1. Shunt Regulator

## PRECISION MICROPOWER SHUNT VOLTAGE REFERENCE

### FEATURES

- Small Packages ..... SOT-23B-3, TO-92, and SO-8
- Output Capacitor Not Required
- Handles Capacitive Loads
- Adjustable Voltage and Fixed Reverse Breakdown Voltage of 1.2V
- Low Output Noise
- Wide Operating Current Range (60µA to 15mA)
- – 40°C to + 85°C Operating Temperature Range

### APPLICATIONS

- Portable, Battery-Powered Equipment
- Data Acquisition Systems
- Instrumentation
- Process Control
- Energy Management
- Product Testing
- Automotive
- Precision Audio Components

### GENERAL DESCRIPTION

For applications in tight quarters, the TCN4041 precision voltage reference is available in a space-saving 3mm x 1.3mm SOT-23B-3 surface mount package. The TCN4041 eliminates the need for an external stabilizing capacitor while maintaining stability with any capacitive load. The minimum operating current is for both the TCN4041-1.2V and the TCN4041-ADJ. Both versions have a maximum operating current of 12mA.

To ensure that the prime parts have an accuracy of better than ±0.5% (C grade) at 25°C, the TCN4041 uses fuse and zener-zap reverse breakdown voltage trim during wafer sort. Low dynamic impedance and bandgap reference temperature drift curvature correction maintain stable reverse breakdown voltage accuracy over a wide range of operating temperatures (– 40°C to + 85°C) and currents from (60µA to 12mA).

The TCN4041 is available in small SOT-23, TO-92, and SO-8 packages.

### ORDERING INFORMATION

Part No.	Output Voltage (V)	Package	Voltage Tolerance Temp. Coefficient Grade
TCN4041C-1.2ENB	1.2	SOT-23B-3*	±0.5%, 100ppm/°C Max (C Grade)
TCN4041C-ADJENB	ADJ	SOT-23B-3*	±0.5%, 100ppm/°C Max (C Grade)
TCN4041C-1.2EOA	1.2	8-Pin SOIC	±0.5%, 100ppm/°C Max (C Grade)
TCN4041C-ADJEOA	ADJ	8-Pin SOIC	±0.5%, 100ppm/°C Max (C Grade)
TCN4041C-1.2EZB	1.2	TO-92	±0.5%, 100ppm/°C Max (C Grade)
TCN4041C-ADJEZB	ADJ	TO-92	±0.5%, 100ppm/°C Max (C Grade)
TCN4041D-2.5EOA	2.5	8-Pin SOIC	±1.0%, 150ppm/°C Max (D Grade)
TCN4041D-4.1EOA	4.1	8-Pin SOIC	±1.0%, 150ppm/°C Max (D Grade)
TCN4041D-1.2ENB	1.2	SOT-23B-3*	±1.0%, 150ppm/°C Max (D Grade)
TCN4041D-ADJENB	ADJ	SOT-23B-3*	±1.0%, 150ppm/°C Max (D Grade)
TCN4041D-1.2EZB	1.2	TO-92	±1.0%, 150ppm/°C Max (D Grade)
TCN4041D-ADJEZB	ADJ	TO-92	±1.0%, 150ppm/°C Max (D Grade)
TCN4041E-1.2ENB	1.2	SOT-23B-3*	±2.0%, 150ppm/°C Max (E Grade)
TCN4041E-1.2EZB	1.2	TO-92	±2.0%, 150ppm/°C Max (E Grade)

**NOTE:** \*SOT-23B-3 is equivalent to the JEDEC (TO-236)

## TCN4041

## ABSOLUTE MAXIMUM RATINGS\* (Note 1)

Reverse Current	20mA
Forward Current	10mA
Power Dissipation (T <sub>A</sub> = 25°C) (Note 2)	
SOT-23B-3 Package	230mW
TO-92 Package	440mW
SO-8 Package	470mW
Storage Temperature	- 65°C to + 150°C
Lead Temperature (Soldering, 10 seconds)	
EOA	+260°C
ENB	+300°C
EZB	+300°C
ESD Susceptibility	

Human Body Model (Note 3)	2kV
Machine Model (Note 3)	200V

\*Functional operation above the absolute maximum stress rating is not implied.

## OPERATING RATINGS (NOTES 1 AND 2)

Temperature Range (T <sub>MIN</sub> ≤ T <sub>A</sub> ≤ T <sub>MAX</sub> )	- 40°C ≤ T <sub>A</sub> ≤ +85°C
Reverse Current	
TCN4041-1.2	60μA to 12mA
TCN40401-ADJ	68μA to 12mA
Output Voltage Range	
TCN4041-ADJ	1.24V to 10V

- NOTES:** 1. Absolute Maximum Ratings indicate limits beyond which damage to the device may occur. Operating Ratings indicate conditions for which the device is functional, but do not guarantee specific performance limits. For guaranteed specifications and test conditions, see *Electrical Characteristics*. The guaranteed specifications apply only for the test conditions listed. Some performance characteristics may degrade when the device is not operated under the listed test conditions.
2. The maximum power dissipation must be derated at elevated temperatures and is dictated by T<sub>JMAX</sub> (maximum junction temperature), θ<sub>JA</sub> (junction to ambient thermal resistance), and T<sub>A</sub> (ambient temperature). The maximum allowable power dissipation at any temperature is PD<sub>MAX</sub> = (T<sub>JMAX</sub> - T<sub>A</sub>) / θ<sub>JA</sub> or the number given in Absolute Maximum Ratings, whichever is lower. For the TCN4041, T<sub>JMAX</sub> = 125°C, and the typical thermal resistance (θ<sub>JA</sub>), when board mounted, is 185°C/W for the M package, 326°C/W for the SOT-23B-3 package, and 180°C/W with 0.4" lead length and 170°C/W with 0.125" lead length for the TO-92-3 package.
3. The human body model is a 100pF capacitor discharged through a 1.5kΩ resistor into each pin. The machine model is a 200pF capacitor discharged directly into each pin.

**ELECTRICAL CHARACTERISTICS:** **Boldface** type specifications apply for T<sub>A</sub> = T<sub>J</sub> = T<sub>MIN</sub> to T<sub>MAX</sub>. All other specifications; T<sub>A</sub> = T<sub>J</sub> = 25°C. All other specifications; T<sub>A</sub> = T<sub>J</sub> = 25°C. The grades C, D, and E designate initial Reverse Breakdown Voltage tolerances of ±0.5%, ±1.0%, and ±2.0%, respectively.

Symbol	Parameter	Test Conditions	TCN4041CEOA TCN4041CENB TCN4041CEZB			TCN4041DEOA TCN4041DENB TCN4041DEZB			TCN4041EENB TCN4041EEZB			Unit
			Min	Typ	Max	Min	Typ	Max	Min	Typ	Max	
V <sub>R</sub>	Reverse Breakdown Voltage	I <sub>R</sub> = 100μA Notes 4, 5	—	1.225	—	—	2.500	—	—	2.500	—	V
	Reverse Breakdown Voltage Tolerance	I <sub>R</sub> = 100μA Notes 4, 5, 6	—		±6 ±14	—		±12 ±24	—		±25 ±36	mV
I <sub>RMIN</sub>	Minimum Operating Current	Notes 4, 5	—	45	60 65	—	45	65 70	—	45	65 70	μA
ΔV <sub>R</sub> /ΔT	Average Reverse Breakdown Voltage Temperature Coefficient	I <sub>R</sub> = 10mA	—	±20	±100	—	±20	±160	—	±20	±150	ppm/°C
		I <sub>R</sub> = 1mA I <sub>R</sub> = 100μA Notes 4, 5	—	±15 ±15		—	±15 ±15		—	±15 ±15		
ΔV <sub>R</sub> /ΔI <sub>R</sub>	Reverse Breakdown Voltage Change with Operating Current Change	I <sub>RMIN</sub> ≤ I <sub>R</sub> ≤ 1mA Notes 4, 5	—	0.7	1.5 2.0	—	0.4	2.0 2.5	—	0.4	2.0 2.5	mV
		1mA ≤ I <sub>R</sub> = 12mA	—	2.5	6.0 8.0	—	2.3	8.0 10.0	—	2.3	8.0 10.0	mV
Z <sub>R</sub>	Reverse Dynamic Impedance	I <sub>R</sub> = 1mA, f = 120Hz, I <sub>AC</sub> = 0.1 I <sub>R</sub> Notes 4, 5	—	0.5	1.5	—	0.3	2.0	—	0.3	2.0	Ω

**TCN4041**

**ELECTRICAL CHARACTERISTICS (Cont.):** Boldface type specifications apply for  $T_A = T_J = T_{MIN}$  to  $T_{MAX}$ . All other specifications;  $T_A = T_J = 25^\circ\text{C}$ . The grades C, D, and E designate initial Reverse Breakdown Voltage tolerances of  $\pm 0.5\%$ ,  $\pm 1.0\%$ , and  $\pm 2.0\%$ , respectively.

Symbol	Parameter	Test Conditions	TCN4041CEOA TCN4041CENB TCN4041CEZB			TCN4041DEOA TCN4041DENB TCN4041DEZB			TCN4041EENB TCN4041EEZB			Unit
			Min	Typ	Max	Min	Typ	Max	Min	Typ	Max	
$e_N$	Wideband Noise	$I_R = 100\mu\text{A}$ , $10\text{Hz} \leq f \leq 10\text{kHz}$ Notes 4, 5	—	20	—	—	20	—	—	20	—	$\mu\text{V/msec}$
$\Delta V_R$	Reverse Breakdown Voltage Long Term Stability	$t = 1000\text{hrs}$ $T = 25^\circ\text{C} \pm 0.1^\circ\text{C}$ $I_R = 100\mu\text{A}$ Notes 4, 5	—	120	—	—	120	—	—	120	—	$\text{ppm}/^\circ\text{C}$

- NOTES:**
- Typicals are at  $T_J = 25^\circ\text{C}$  and represent most likely parametric norm.
  - Limits are 100% production tested at  $25^\circ\text{C}$ .
  - The boldface (over-temperature) limit for Reverse Breakdown Voltage Tolerance is defined as the room temperature Reverse Breakdown Voltage Tolerance  $\pm[(\Delta V_R/\Delta T)(65^\circ\text{C})(V_R)]$ .  $\Delta V_R/\Delta T$  is the  $V_R$  temperature coefficient,  $65^\circ\text{C}$  is the temperature range from  $-40^\circ\text{C}$  to the reference point of  $25^\circ\text{C}$ , and  $V_R$  is the reverse breakdown voltage. The total over-temperature tolerance for the different grades is shown below:  
 C-grade:  $\pm 1.15\% = \pm 0.5\% \pm 100\text{ppm}/^\circ\text{C} \times 65^\circ\text{C}$   
 D-grade:  $\pm 1.98\% = \pm 1.0\% \pm 150\text{ppm}/^\circ\text{C} \times 65^\circ\text{C}$   
 E-grade:  $\pm 2.98\% = \pm 2.0\% \pm 150\text{ppm}/^\circ\text{C} \times 65^\circ\text{C}$
  - When  $V_{OUT} \leq 1.6\text{V}$ , the TCN4041-ADJ in the SOT-23B package must operate at reduced  $I_R$ . This is caused by the series resistance of the die attach between the die (-) output and the package (-) output pin. See the Output Saturation (SOT23-B only) curve in the *Typical Characteristics* section.
  - Reference voltage and temperature coefficient will change with output voltage. See *Typical Characteristics* curves.

**PIN CONFIGURATION**

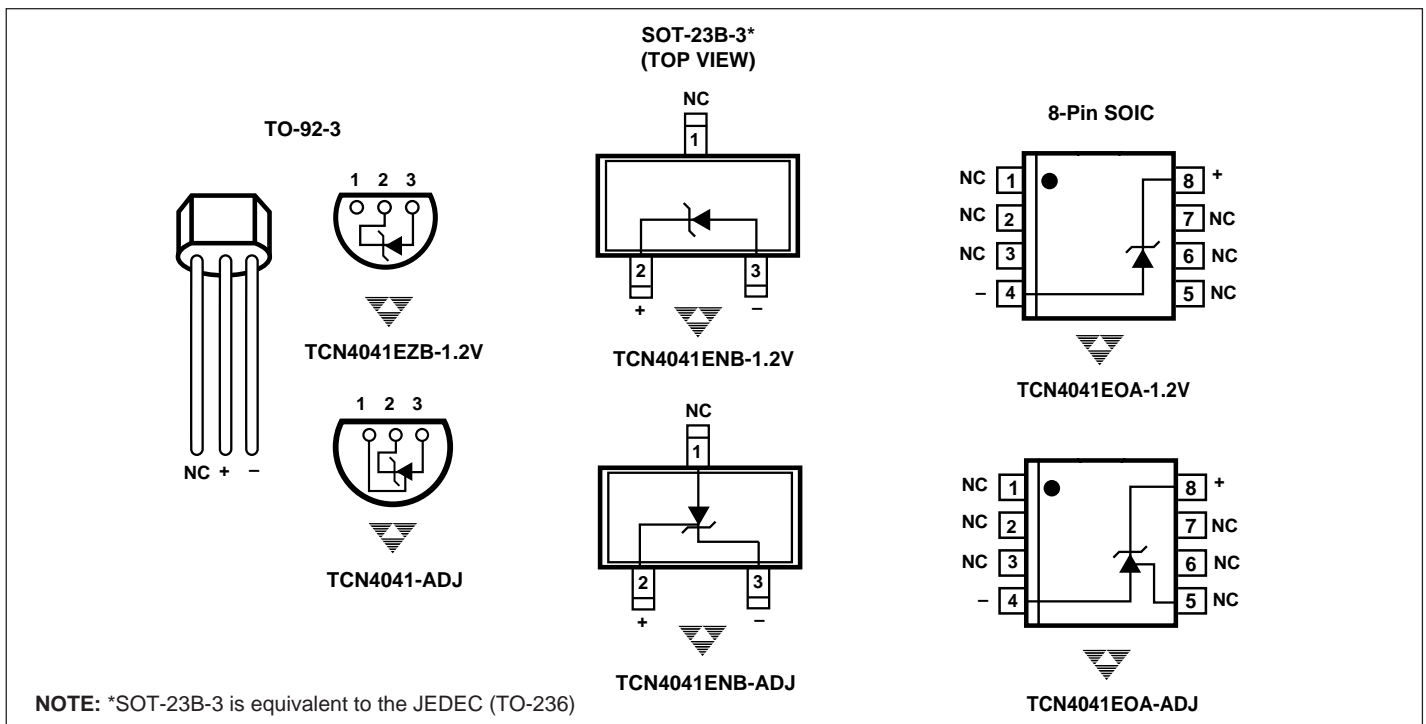

## TCN4041

## PIN DESCRIPTION

Pin No. (SOT-23B-3)	Pin No. TO-92	Pin No. 8-Pin SOIC	Symbol	Description
1	1	1	NC	No connection
		2	NC	No connection
		3	NC	No connection
2	2		+	Positive terminal
3	3		-	Negative terminal
		4	-	Negative terminal
		5	NC	No connection
		6	NC	No connection
		7	NC	No connection
		8	+	Positive terminal

## APPLICATIONS INFORMATION

Available in space-saving SOT-23B-3 surface mount packages, the TCN4041 is a precision micro-power curvature-corrected bandgap shunt voltage reference. It is designed for stable operation without an external capacitor connected between the “+” pin and the “-” pin. The TCN4041 also remains stable, however, if a bypass capacitor is used. The device is available in either a fixed 1.2V or an adjustable reverse breakdown voltage. The minimum operating current is 60mA, and the maximum operating current is 12mA for both options.

TCN4041s in the SOT-23 package have pin 1 connected as the (-) output. (Die attach interface contact). Therefore, pin 1 of the TCN4041-1.2 must be left floating or connected to pin 3, and pin 1 on the TCN4041-ADJ is the (-) output.

In a conventional shunt regulator application, an external series resistor ( $R_S$ ) is connected between the supply voltage and the TCN4041 (Figure 1).  $R_S$  determines the current that flows through the load ( $I_L$ ) and the TCN4041 ( $I_Q$ ). Even when the supply voltage is at its minimum, and the load current is at its maximum value,  $R_S$  should be small enough to supply at least the minimum acceptable  $I_Q$  to the TCN4041 since load current and supply voltage may vary. Conversely, when the supply voltage is at its maximum and  $I_L$  is at its minimum,  $R_S$  should be large enough that the current flowing through the TCN4041 is less than 12mA.

$R_S$  is determined by the supply voltage, ( $V_S$ ), the load and operating current, ( $I_L$  and  $I_Q$ ), and the TCN4041's reverse breakdown voltage,  $V_R$ .

$$R_S = \frac{V_S - V_R}{I_L + I_Q}$$

Output voltage on the TCN4041-ADJ can be adjusted to any value between 1.24V and 10V. It is a function of the internal reference voltage ( $V_{REF}$ ) and the ratio of the external feedback resistors (see Figure 2). The output can be found with the equation (where  $V_{OUT}$  is the desired output voltage):

$$V_{OUT} = V_{REF} (R_2/R_1 + 1)$$

Equation 1.

The value of the internal  $V_{REF}$  is a function of  $V_O$ . The “corrected”  $V_{REF}$  can be determined by (where  $V_O$  is the desired output voltage):

$$V_{REF}' = V_{OUT} (\Delta V_{REF}/\Delta V_{OUT}) + V_Y$$

Equation 2.

$\Delta V_{REF}/\Delta V_{OUT}$  is typically -1.3mV/V, and  $V_Y = 1.240V$ . Replace the value of  $V_{REF}'$  in Equation 1 with the value determined using Equation 2.

The actual output voltage can deviate from that predicted by the typical  $\Delta V_{REF}/\Delta V_O$  in Equation 2. The worst case  $\Delta V_{REF}/\Delta V_{OUT}$  for C-grade parts is -2.5mV/V and  $V_Y = 1.246V$ ; for D-grade, the worst case is -3.0mV/V and  $V_Y = 1.248V$ .

The difference in output voltage resulting from typical worst case values are shown in the following example: Let  $V_O = +9V$ . Using the typical value of  $\Delta V_{REF}/\Delta V_{OUT}$ ,  $V_{REF}$  is 1.228; choosing a value of  $R_1 = 10k\Omega$ ,  $R_2 = 63.272k\Omega$ . The output voltage, when using worst case  $\Delta V_{REF}/\Delta V_{OUT}$  for C-grade and D-grade parts, is 8.965V and 8.946V, respectively. This could result in errors as large as 0.39% for C-grade, and 0.59% for D-grade parts. However, resistor values resulting from the typical value of  $\Delta V_{REF}/\Delta V_{OUT}$  will work most of the time, requiring no additional adjustments.



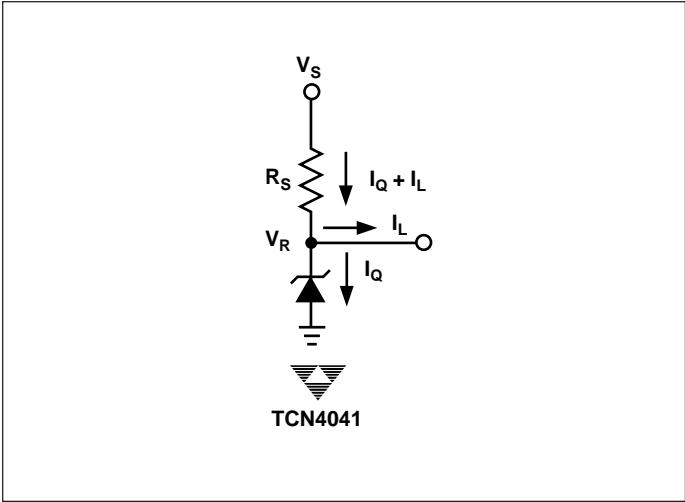

Figure 1. Shunt Regulator

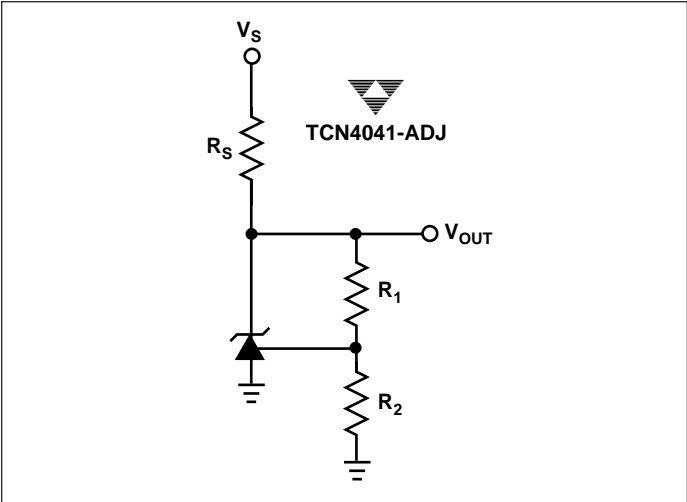

Figure 2. Adjustable Shunt