

POWER CMOS DRIVERS WITH VOLTAGE TRIPLER

FEATURES

- Power driver with on Board Voltage Booster
- Low I_{DD} < 4 mA
- Small Package 8-Pin PDIP
- Under-Voltage Circuitry
- Fast Rise-Fall Time < 40nsec @ 1000pF
- Below-Rail Input Protection

APPLICATIONS

- Raises 5V to drive higher-V_{gs} (ON) MOSFETs
- Eliminates one system power supply

PIN CONFIGURATIONS

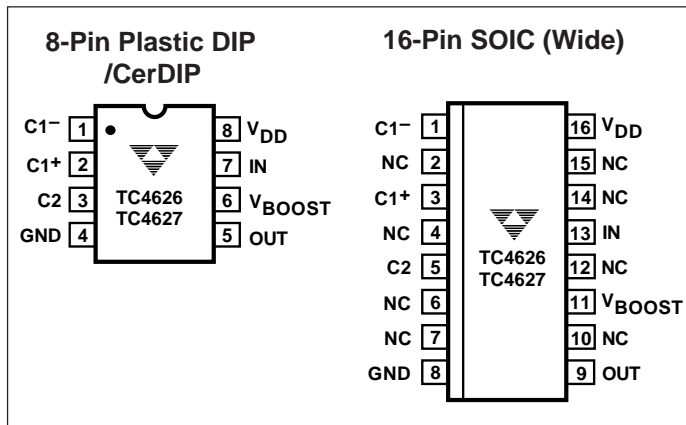

GENERAL DESCRIPTION

The TC4626/4627 are single CMOS high speed drivers with an on-board voltage boost circuit. These parts work with an input supply voltage from 4 to 6 volts. The internal voltage booster will produce a V_{BOOST} potential up to 12 volts above V_{IN}. This V_{BOOST} is not regulated, so its voltage is dependent on the input V_{DD} voltage and output drive loading requirements. An internal undervoltage lockout circuit keeps the output in a low state when V_{BOOST} drops below 7.8 volts. Output is enabled when V_{BOOST} is above 11.3 volts.

ORDERING INFORMATION

Part No.	Package	Temp. Range
TC4626COE	16-Pin SOIC (Wide)	-55°C to +125°C
TC4626CPA	8-Pin Plastic DIP	-40°C to +85°C
TC4626EOE	16-Pin SOIC (Wide)	-40°C to +85°C
TC4626EPA	8-Pin Plastic DIP	-0°C to +70°C
TC4626MJA	8-Pin CerDIP	-0°C to +70°C
TC4627COE	16-Pin SOIC (Wide)	-55°C to +125°C
TC4627CPA	8-Pin Plastic DIP	-40°C to +85°C
TC4627EOE	16-Pin SOIC (Wide)	-40°C to +85°C
TC4627EPA	8-Pin Plastic DIP	-0°C to +70°C
TC4627MJA	8-Pin CerDIP	-0°C to +70°C

4

FUNCTIONAL BLOCK DIAGRAM

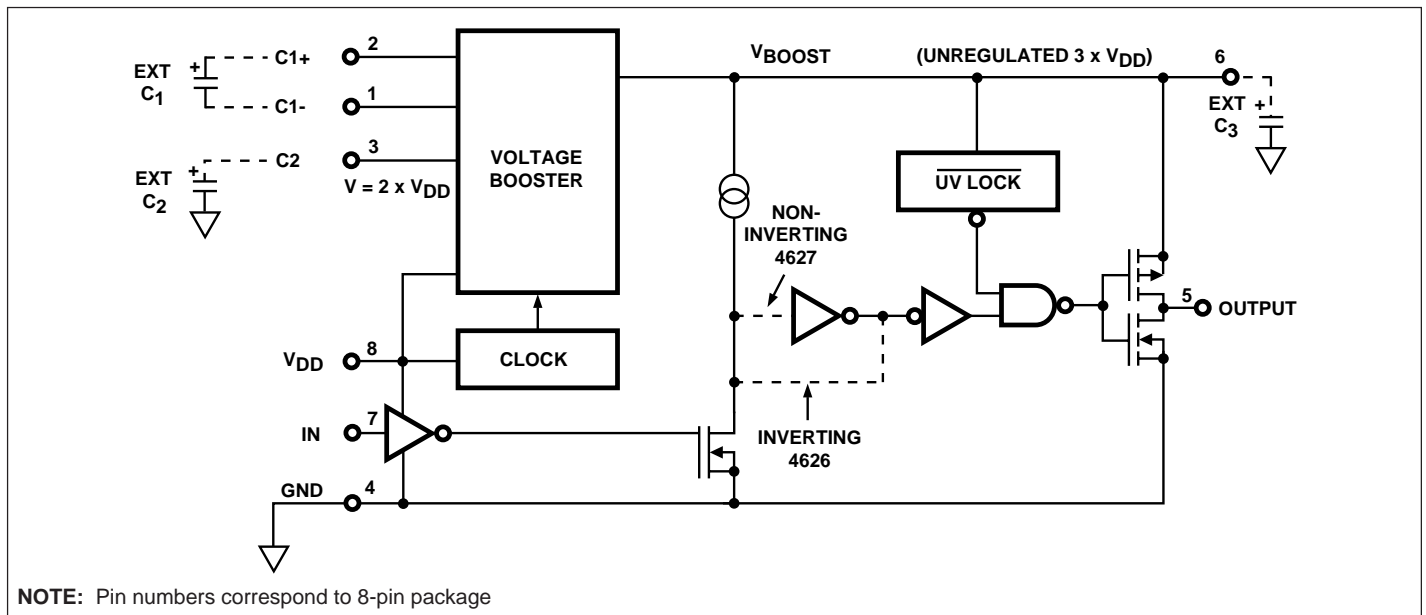

POWER CMOS DRIVERS WITH VOLTAGE TRIPLER

TC4626 TC4627

ABSOLUTE MAXIMUM RATINGS

Package Power Dissipation ($T_A \leq 70^\circ\text{C}$)	
PDIP	730mW
CerDIP	800mW
SOIC	760mW
Derating Factor	
PDIP	5.6 mW/°C Above 36°C
CerDIP	6.0 mW/°C

Supply Voltage	6.2V
Input Voltage, Any Terminal	$V_S + 0.3\text{V to GND} - 0.3\text{V}$
Operating Temperature: M Version	- 55°C to +125°C
E Version	- 40°C to +85°C
C Version	0°C to +70°C
Maximum Chip Temperature	+150°C
Storage Temperature	- 65°C to +150°C
Lead Temperature (10 sec)	+300°C

ELECTRICAL CHARACTERISTICS: $T_A = 25^\circ\text{C}$ $V_{DD} = 5\text{V}$ $C_1 = C_2 = C_3 = 10\mu\text{F}$ unless otherwise specified.

Symbol	Parameter	Test Conditions	Min	Typ	Max	Unit
Driver Input						
V_{IH}	Logic 1, Input Voltage		2.4	—	—	V
V_{IL}	Logic 0, Input Voltage		—	—	0.8	V
I_{IN}	Input Current	$0\text{V} \leq V_{IN} \leq V_{DRIVE}$	- 1	—	1	μA
Driver Output						
V_{OH}	High Output Voltage		$V_{BOOST} - 0.025$	—	—	V
V_{OL}	Low Output Voltage		—	—	0.025	V
R_O	Output Resistance, High	$I_{OUT} = 10\text{ mA}, V_{DD} = 5\text{V}$	—	10	15	Ω
R_O	Output Resistance, Low	$I_{OUT} = 10\text{ mA}, V_{DD} = 5\text{V}$	—	8	10	Ω
I_{PK}	Peak Output Current		—	1.5	—	A
Switching Time						
t_R	Rise Time	Test Figure 1,2	—	33	40	nsec
t_F	Fall Time	Test Figure 1,2	—	27	35	nsec
t_{D1}	Delay Time	Test Figure 1,2	—	35	45	nsec
t_{D2}	Delay Time	Test Figure 1,2	—	45	55	nsec
F_{MAX}	Maximum Switching Frequency	Test Figure 1 $V_{DD} = 5\text{V}, V_{BOOST} > 8.5\text{V}$	1.0	—	—	MHz
Voltage Booster						
R_3	Voltage Tripler Output Source Resistance	$I_L = 10\text{ mA}, V_{DD} = 5\text{V}$	—	300	400	Ω
R_2	Voltage Doubler Output Source Resistance		—	120	200	Ω
F_{OSC}	Oscillator Frequency		12	—	28	kHz
V_{OSC}	Oscillator Amplitude Measured at C1-	$R_{LOAD} = 10\text{k}\Omega$	4.5	—	10	V
UV @ V_{BOOST}	Undervoltage Threshold		7.0	7.8	8.5	V
V_{START} @ V_{BOOST}	Start Up Voltage		10.5	11.3	12	V
V_{BOOST} @ $V_{DD} = 5\text{V}$		No Load	14.6	—	—	V
Power Supply						
I_{DD}	Power Supply Current	$V_{IN} = \text{LOW or HIGH}$	—	—	2.5	mA
V_{DD}	Supply Voltage		4.0	—	6.0	V

POWER CMOS DRIVERS WITH VOLTAGE TRIPLER

TC4626
TC4627

ELECTRICAL CHARACTERISTICS: T_A = Over Operating Temperature Range $V_{DD} = 5V$ $C1 = C2 = C3 = 10\mu F$ unless otherwise specified.

Symbol	Parameter	Test Conditions	Min	Typ	Max	Unit
Driver Input						
V_{IH}	Logic 1, Input Voltage		2.4	—	—	V
V_{IL}	Logic 0, Input Voltage		—	—	0.8	V
I_{IN}	Input Current	$0V \leq V_{IN} \leq V_{BOOST}$	- 10	—	10	μA
Driver Output						
V_{OH}	High Output Voltage		$V_{DRIVE} - 0.025$	—	—	V
V_{OL}	Low Output Voltage		—	—	0.025	V
R_O	Output Resistance, High	$I_{OUT} = 10\text{ mA}$, $V_{DD} = 5V$ C & E Version ($T_A = 70^\circ C$ or $85^\circ C$) M Version ($T_A = 125^\circ C$)	— —	15 15	20 25	Ω
R_O	Output Resistance, Low	$I_{OUT} = 10\text{ mA}$, $V_{DD} = 5V$ C & E Version ($T_A = 70^\circ C$ or $85^\circ C$) M Version ($T_A = 125^\circ C$)	— —	10 10	13 15	Ω
I_{PK}	Peak Output Current		—	1.5	—	A
Switching Time						
t_R	Rise Time	Test Figure 1,2	—	—	55	nsec
t_F	Fall Time	Test Figure 1,2	—	—	50	nsec
t_{D1}	Delay Time	Test Figure 1,2	—	—	60	nsec
t_{D2}	Delay Time	Test Figure 1,2	—	—	70	nsec
F_{MAX}	Maximum Switching Frequency	Test Figure 1 $V_{DD} = 5V$, $V_{BOOST} > 8.5V$	750	—	—	kHz
Voltage Booster						
R_3	Voltage Boost Output Source Resistance	$I_L = 10\text{ mA}$, $V_{DD} = 5V$	—	400	500	Ω
R_2	Voltage Doubler Output Source Resistance		—	170	300	Ω
F_{OSC}	Oscillator Frequency		5	—	50	kHz
V_{OSC}	Oscillator Amplitude Measured at C1-	$R_{LOAD} = 10k\Omega$	4.5	—	10	V
UV @ V_{BOOST}	Undervoltage Threshold		7.0	7.8	8.5	V
V_{START} @ V_{BOOST}	Start Up Voltage		10.5	11.3	12	V
V_{BOOST} @ $V_{DD} = 5V$		No Load	14.6	—	—	V
Power Supply						
I_{DD}	Power Supply Current	$V_{IN} = \text{LOW or HIGH}$	—	—	4	mA
V_{DD}	Supply Voltage		4.0	—	6.0	V

4

POWER CMOS DRIVERS WITH VOLTAGE TRIPLER

TC4626
TC4627

SWITCHING TIME TEST CIRCUITS

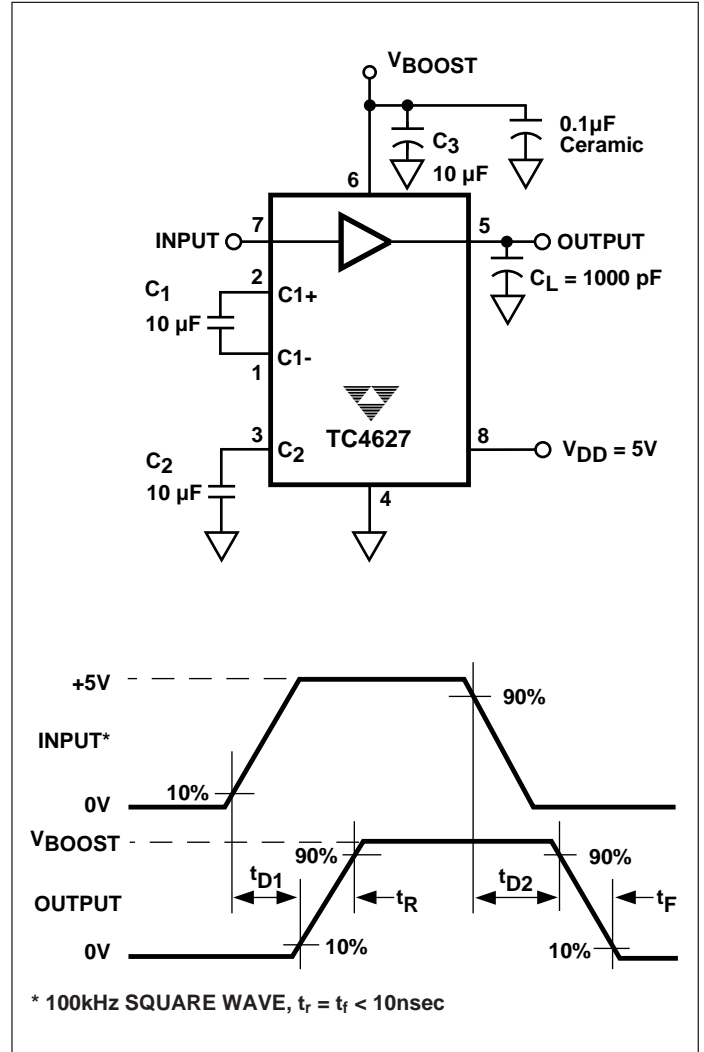
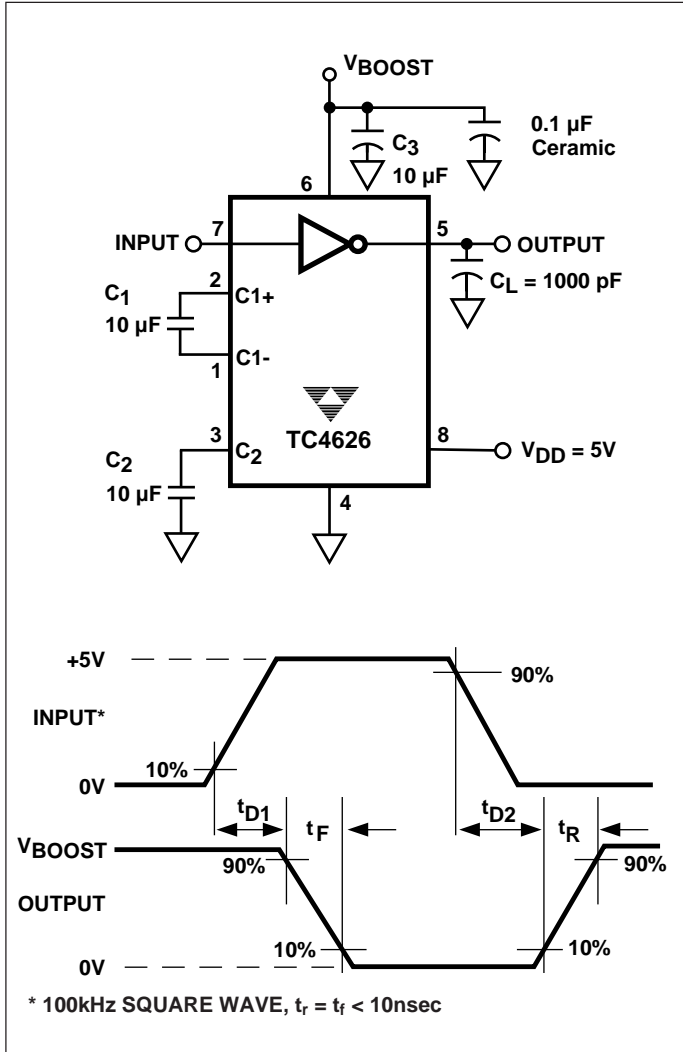

BOOSTER FUNCTION

The voltage booster is an unregulated voltage tripler circuit. The tripler consists of three sets of internal switches and three external capacitors. S1a and S1b charge capacitor C1 to V_{DD} potential. S2a and S2b add C1 potential to V_{DD} input to charge C2 to $2 \times V_{DD}$. S3a and S3b add C1 potential to C2 to charge C3 to $3 \times V_{DD}$. The position of the switches is controlled by the internal 4 phase clock.

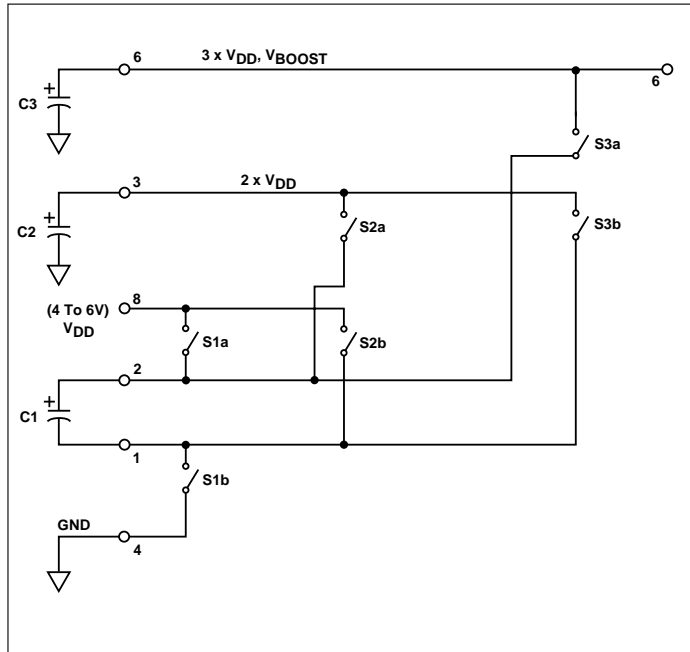

Voltage Booster

Pin 1 & 2 Waveforms

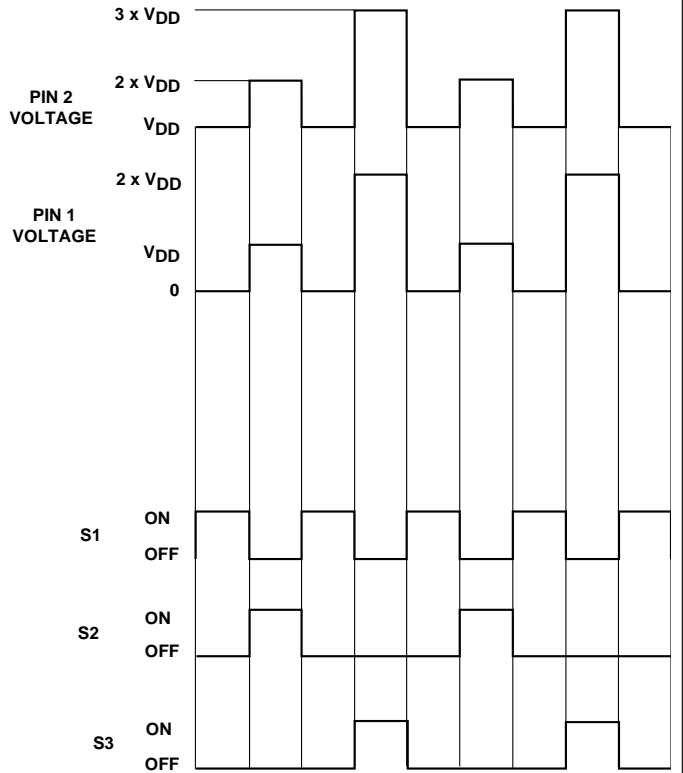

Position of Switches

POWER CMOS DRIVERS WITH VOLTAGE TRIPLER

TC4626
TC4627

TYPICAL CHARACTERISTICS

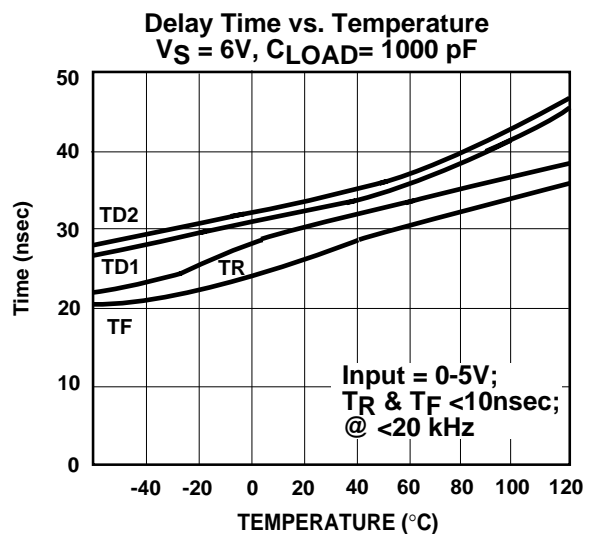
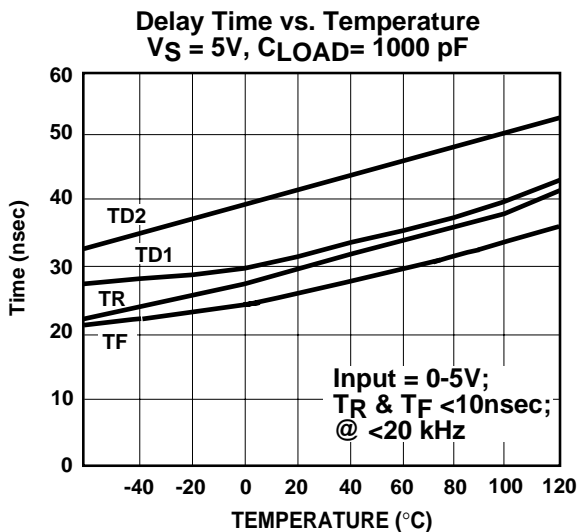
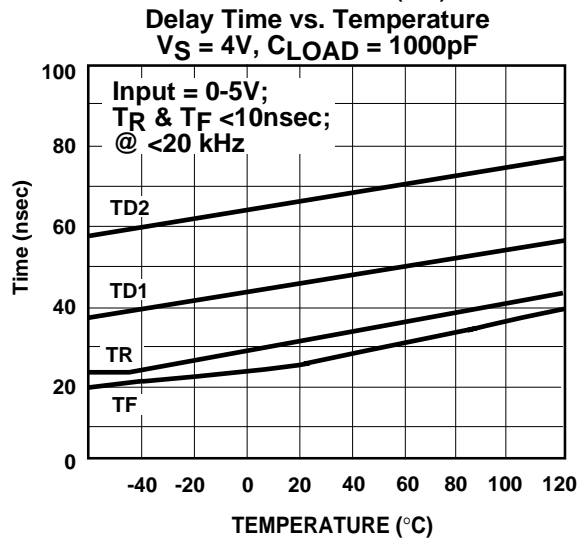
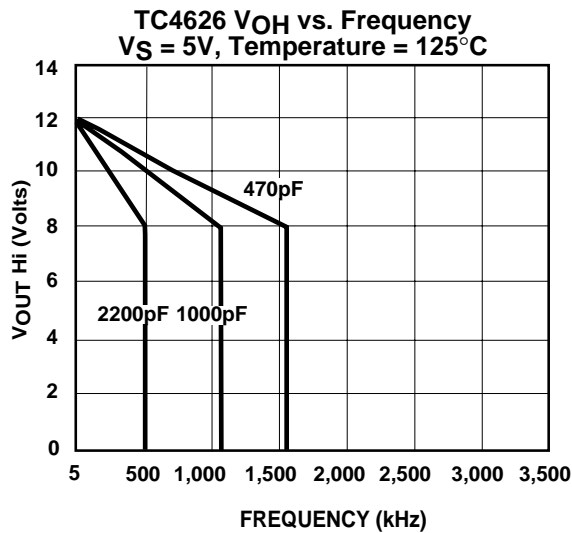
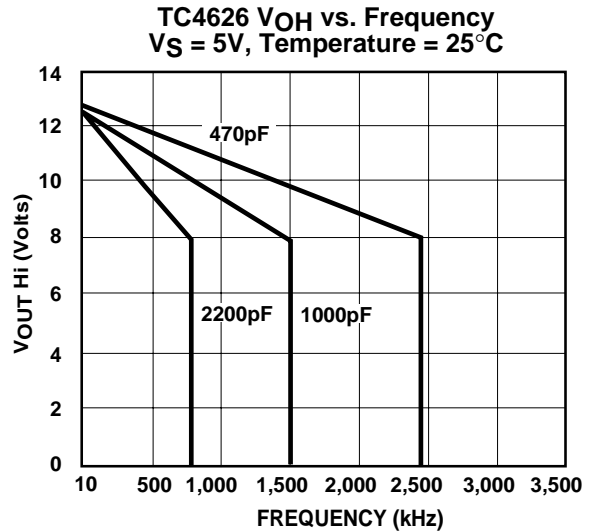
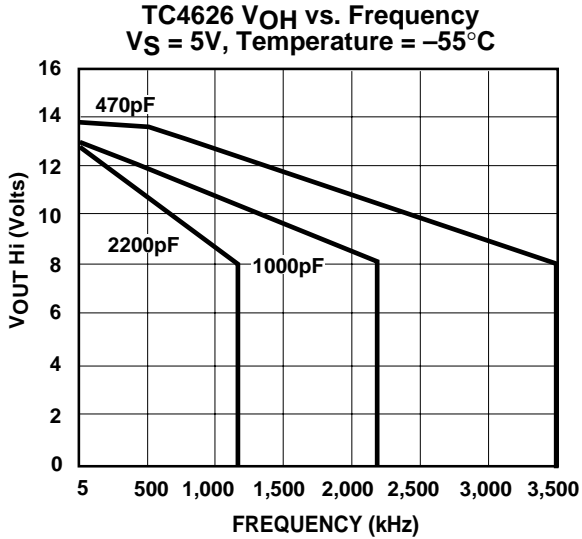

TYPICAL CHARACTERISTICS (Cont.)

