

Advanced Information

April 2000

DESCRIPTION

The 5504 is a low cost, high performance direct conversion receiver (DCR) specifically designed for digital wireless applications. The DCR architecture provides a receiver design with fewer external components than the conventional dual conversion approach. The 5504 is designed to operate over an input frequency range of 950 to 2150 MHz. The device accepts an input signal in this frequency range and down converts directly to baseband. The local oscillator signal is generated by a completely integrated phase lock loop that is fully programmable through a standard serial port interface.

FEATURES

- **Wideband I/Q demodulator**
 - RF input 950 to 2150 MHz
 - External lowpass filter
 - Integrated post-filter baseband drivers
- **Integrated VCO and frequency synthesizer**
- **AGC Amplifier**

APPLICATIONS

- **Digital Satellite**
- **VSAT Receivers**

BLOCK DIAGRAM

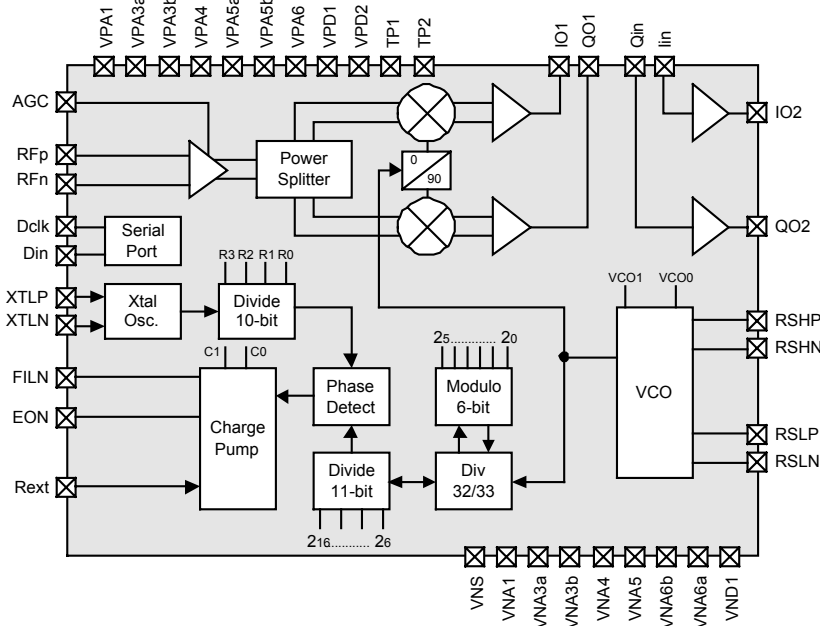

5504 DCR

Direct Conversion Receiver

FUNCTIONAL DESCRIPTION

AGC Amplifier

The 5504 RF input can be driven differentially or single ended. The *RFp* and *RFn* inputs are self-biasing and are designed to be driven from a 50 Ohm source. For single-ended operation, the *RFn* pin should be AC coupled to analog ground. A gain control input, AGC, provides a 25 dB gain variation with 0V providing minimum gain and 4V providing maximum gain.

I/Q Mixer

The AGC amplifier drives the RF port of two identical double balanced mixers. The LO ports of these mixers are driven from an on-chip quadrature network.

Low Pass Filtering and Buffering

Following each mixer, a buffer amplifier is provided for driving an external passive low-pass filter. The nominal output impedance for IO1 and QO1 is 50 ohms. A second high impedance buffer amplifier is provided (*IIN* or *QIN*) for additional gain and isolation after the filter. The figure below shows a typical filter designed for 20 Megasympol per second operation:

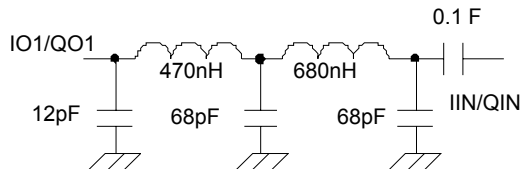

Dual VCO

The 5504 uses two VCOs to cover the entire specified tuning range. Both VCOs use nearly identical architecture with the only difference being slight design modifications to optimize the range of operation. The lower range VCO requires an external resonator that supports a tuning range of 950 to 1473 MHz. The higher range VCO requires a similar resonator with inductor values designed to support the range of 1390 to 2150 MHz. A typical lumped-element resonator circuit incorporating varactor tuning is shown in the following figure:

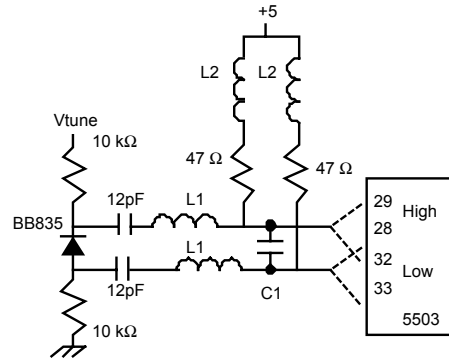

Note: A separate resonator circuit is required for each oscillator

PLL Synthesizer

The synthesizer derives its reference from a source which can be either an externally derived clock or an external crystal coupled to the internal oscillator. This source drives a programmable reference divider with 15 preset divide ratios from 2 to 320. This divider output provides the PLL reference by driving one input of a phase/frequency detector. The VCO output drives a divider chain incorporating a variable modulus prescaler and divider. The divider is programmed by a 17-bit control word. This divider chain output drives the other input of the phase/frequency detector.

Loop Filter

The phase/frequency detector interface consists of two ports, *FILN* and *EON*. The *EON* drives the base of an external NPN transistor, and the *FILN* provides a feedback path for the loop filter elements. The external transistor permits VCO tune voltages of greater than 30V and also provides the final stage of the loop amplifier. Below is shown a typical loop filter:

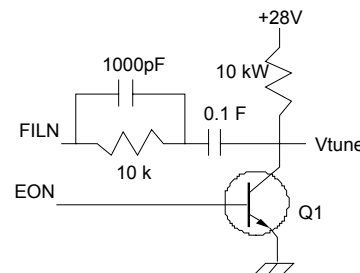

5504 DCR Direct Conversion Receiver

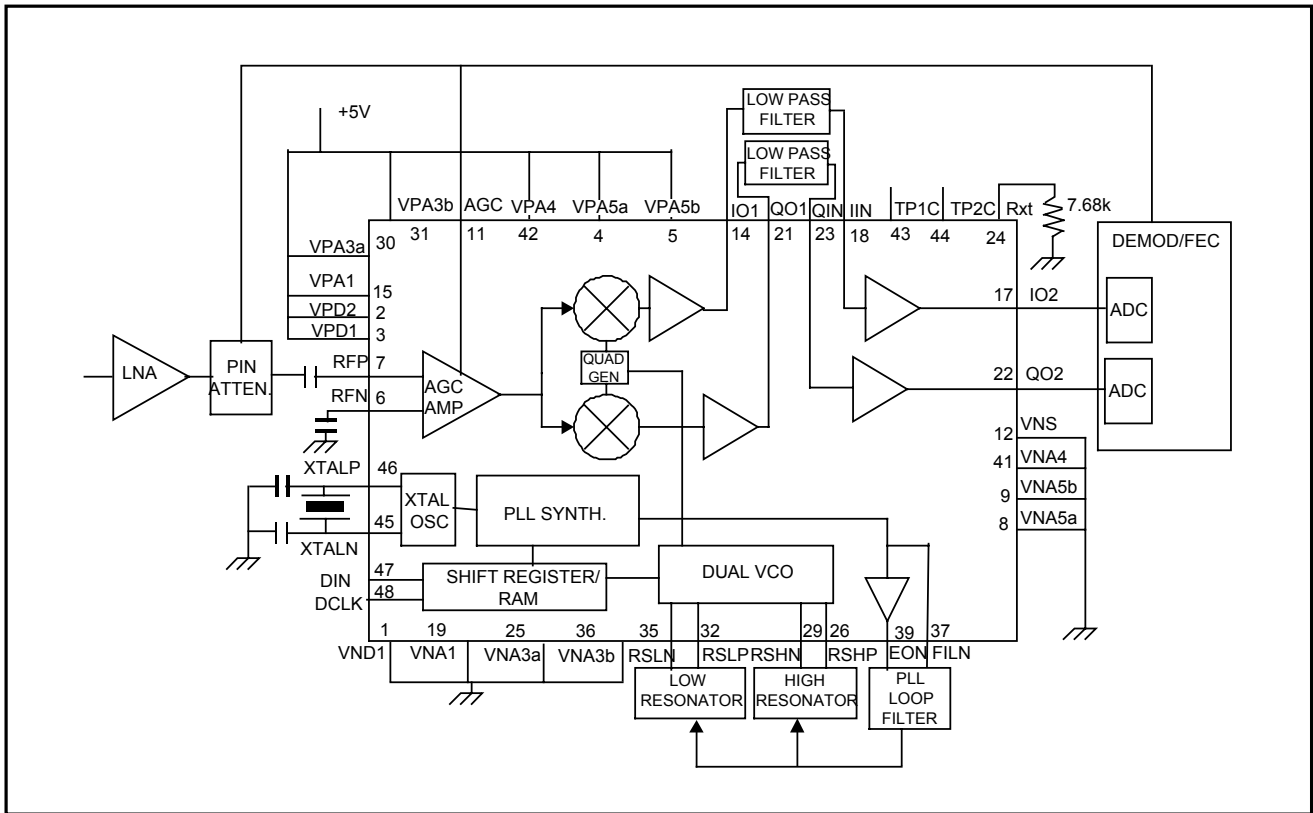

DCR Application Drawing

5504 DCR

Direct Conversion Receiver

PIN DESCRIPTIONS

ANALOG PINS

NAME	TYPE	DESCRIPTION
RFP, RFN	I	RF inputs: balanced differential inputs to the receiver. The input signals placed on this line are amplified with a variable gain amplifier before being passed to the I/Q demodulator.
AGC	I	Automatic gain control input. A voltage from 0 to 4 volts on this pin varies the input amplifier gain from minimum to maximum. The gain increase is 25 dB typical
Eon, Filn	I/O	External loop filter interface. <i>Eon</i> drives the base of an external common emitter transistor. <i>Filn</i> is the feedback input from the loop filter capacitor.
XTLP, XTLN	I	Reference crystal input. An external crystal connected between these pins establishes the reference frequency for the PLL synthesizer. Following this oscillator is a programmable divider that establishes the synthesizer step size.
IO2, QO2	O	Baseband outputs. These typically drive an A/D converter prior to digital demodulation and processing.
IO1, QO1	O	I and Q channel outputs to external low pass filter. An external series resistor can be connected between this output and the filter to provide the source match.
IIN, QIN	I	I and Q channel inputs from external low pass filter. These are high impedance inputs (>5000Ω). The low pass filter must be designed for low input and high output impedance.
Rxt	I	External reference resistor. This resistor is connected to ground and must be 7.68k ±1%. It is used as a reference for internal bias currents.
RSHP, RSHN	I	High range VCO resonator inputs
RSLP, RSLN	I	Low range VCO resonator inputs

DIGITAL PINS

Din	I/O	I2C data. This signal is connected to the I2C internal block. An external resistor (typically 2.2 kΩ) is connected between Din and Vcc for proper operation
Dclk	I	I2C clock Input. <i>Dclk</i> should nominally be a square wave with a maximum frequency of 400kHz. SCL is generated by the system I2C master.

5504 DCR Direct Conversion Receiver

POWER PINS

VPA1, VPA3a, VPA3b, VPA4, VPA5a, VPA5b, VPA6	I	Analog Vcc pins
VPD1, VPD2	I	Digital Vcc pin.
VNA1, VNA3a, VNA3b, VNA4, VNA6, VNA7	I	Analog ground pins.
VND1	I	Digital ground pin.
VNS	I	Substrate ground pin.

MICROCONTROLLER SERIAL INTERFACE

I²C REGISTERS: WRITE MODE

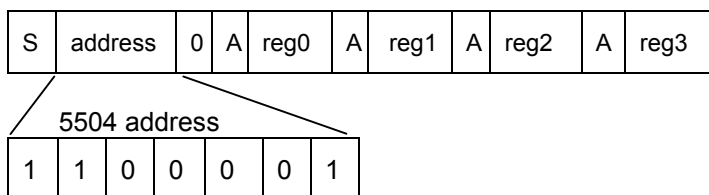

S: start bit

A: acknowledge bit

P: stop bit

TABLE 1: MICROCONTROLLER INTERFACE REGISTER

REGISTER	7(MSB)	6	5	4	3	2	1	0 (LSB)
0	0	2^{14}	2^{13}	2^{12}	2^{11}	2^{10}	2^9	2^8
1	2^7	2^6	2^5	2^4	2^3	2^2	2^1	2^0
2	1	2^{16}	2^{15}	x	R3	R2	R1	R0
3	C1	C0	test1	test0	Pdisab	vco1	vco0	x

5504 DCR

Direct Conversion Receiver

DESCRIPTION OF INTERNAL REGISTERS

Register 0 VCO divide ratio, bits 14 through 8, msb always set to 0

Register 1 VCO divide ratio, bits 7 through 0

Register 2 msb not used. Always set to 1
 VCO divide ratio, bits 16 and 15
 R3, R2, R1, R0 Reference division ratio, as shown in following table:

R3	R2	R1	R0	Reference division ratio
0	0	0	0	2
0	0	0	1	4
0	0	1	0	8
0	0	1	1	16
0	1	0	0	32
0	1	0	1	64
0	1	1	0	128
0	1	1	1	256
1	0	0	0	Undefined
1	0	0	1	5
1	0	1	0	10
1	0	1	1	20
1	1	0	0	40
1	1	0	1	80
1	1	1	0	160
1	1	1	1	320

Register 3 C1, C0 Phase detector current control, as shown in following table:

ipump word		Phase Detector charge current μA
C1	C0	
0	0	100
0	1	200
1	0	300
1	1	400

5504 DCR

Direct Conversion Receiver

test0, test1 Test point select as shown in following table:

test1	test0	tp1	tp2
0	0	disabled	disabled
0	1	pump up	pump down
1	0	M cnt	N cnt
1	1	prescaler	modulus

Pdisab Phase detector disable (1 = disable, 0 = enable)

(vco0, vco1) Vco select word as shown in following table:

vco1	vco0	Low band VCO	High band VCO
0	0	disabled	disabled
0	1	enabled	disabled
1	0	disabled	enabled
1	1	undefined	undefined

5504 DCR

Direct Conversion Receiver

ABSOLUTE MAXIMUM RATINGS

Operation beyond maximum rating may permanently damage the device.

PARAMETER	RATING
Storage temperature	-55 to 150 °C
Junction operating temperature	+110 °C
Positive supply voltage (Vp)	-0.3 to 6V
Voltage applied to any pin	-0.3V to VCCn+0.3V

TARGET SPECIFICATIONS

Unless otherwise specified: 0° < Ta < 70 °C; positive power supply (VCCn) = +5.0 V ±5%.

OPERATING CHARACTERISTICS

PARAMETER	CONDITION	MIN	NOM	MAX	UNIT
Supply current	All outputs loaded		120	150	mA
Digital I/O Characteristics (Din, Dclk)					
High level input voltage		2		Vcc+0.3	V
Low level input voltage		Gnd - 0.3		0.8	V
High level input current	Vin = Vcc - 1.0V			100	uA
Low level input current	Vin = 1.0V			- 400	uA
Receiver Characteristics Unless otherwise noted, input source impedance is 75 Ω					
Input impedance, RFp	RFn bypassed to ground with 100 pf	40	70	100	Ω
Input signal range		-50		-28	dBm
Input frequency range		950		2150	MHz
AGC Range	0V < V _{AGC} < 4V	22	25		dB
AGC Control Input current	0V < V _{agc} < 4V		7	10	uA
DCR Max. Gain, Lower Band Range	Fin = 950 MHz, AGC = 4V, Gain measured from RFp to IO2/Q02	50			dB
DCR Max. Gain, Upper Band Range	Fin = 2150 MHz, AGC = 4V, Gain measured from RFp to IO2/Q02	49			dB
Noise figure	Measured at maximum gain		15	18	dB
2 nd order IIP	Vrf_in = -28 dBm/tone	10	12		dBm
3 rd order IIP	Vrf_in = -28 dBm/tone	-4	-2		dBm
Lo Leakage	Measured at RFp		-70	-60	dBm
VCO Characteristics					
Tuning range, Low OSC	L ₁ = 8.2nH L ₂ = 27nH C ₁ = 1pF	950		1475	MHz
Tuning range, High OSC	L ₁ = 3.9nH L ₂ = 22nH C ₁ = .6pF	1380		2150	MHz
Phase Noise	10kHz offset		-78	-75	dBc/Hz
Crystal Characteristics					
Frequency		6	8	10	MHz
ESR				100	Ω
Load Capacitance			20		pF

5504 DCR Direct Conversion Receiver

OPERATING CHARACTERISTICS (continued)

Low Pass Filter Interface					
IO1, QO1 output impedance		40	50	60	Ω
Filter Loss				1db	
Filter Input Impedance		50		10000	Ω
I and Q Buffer Amplifier (each output loaded with 4pF in parallel with 20kΩ)					
Input resistance	Freq. = 30 MHz	5000	8000	10000	Ω
Input capacitance	Freq. = 30 MHz		5pf		
Voltage Gain	Freq. = 30 MHz	14	15	16	dB
Output impedance				10	Ω
I/Q output amplitude		0.75	0.5		Vpp
-3dB frequency, Frf-Flo		78	82		MHz
Buffer THD			1%	2%	
Amplitude and Phase Characteristics					
I/Q quadrature accuracy		-3		+3	degree
I/Q amplitude matching		-1		+1	dB

5504 DCR

Direct Conversion Receiver

PACKAGE PIN DESIGNATIONS

(Top View)

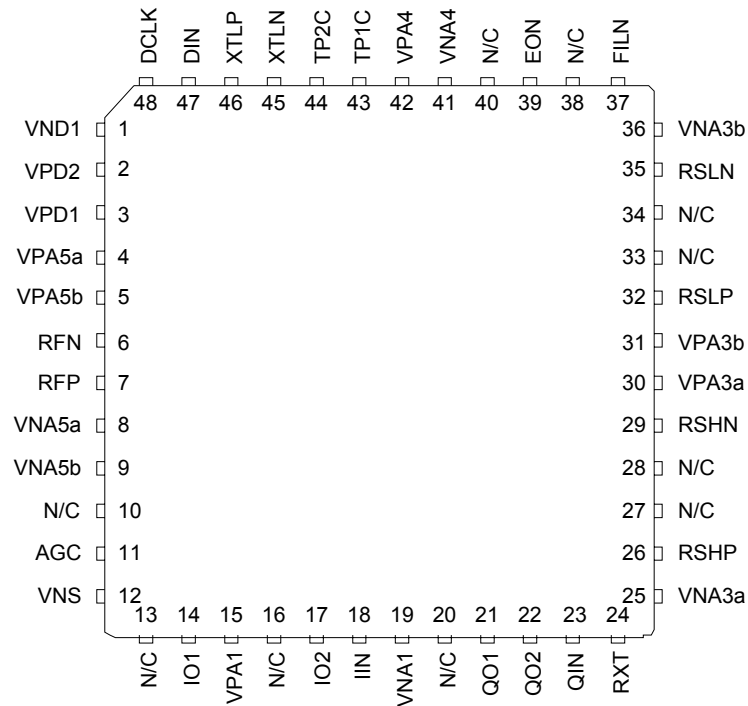

48-TQFP (JEDEC LQFP)
5504-CGT

5504 DCR Direct Conversion Receiver

MECHANICAL DRAWING

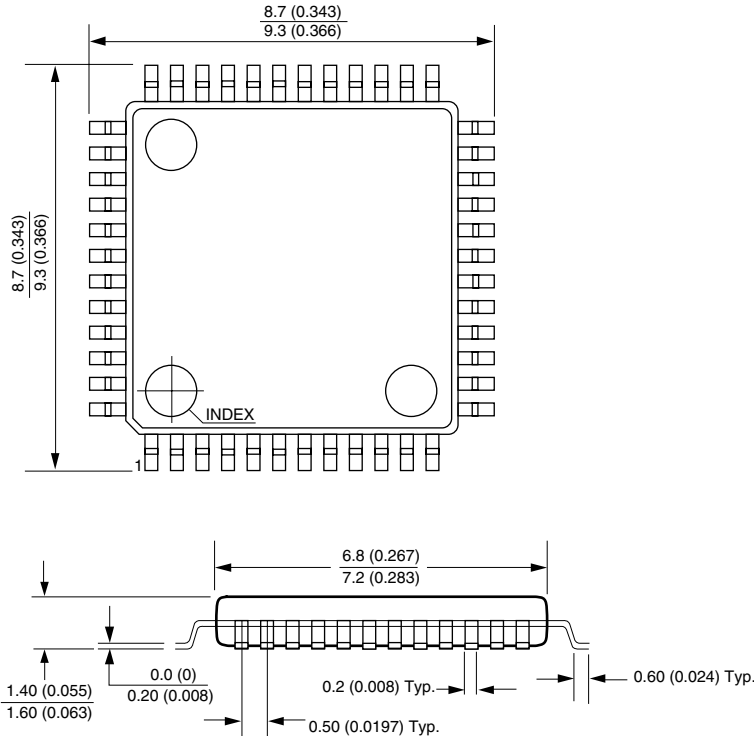

48-Lead Thin Quad Flatpack (JEDEC LQFP)

Note: Controlling dimensions are in mm

PART DESCRIPTION	ORDER NO.	PACKAGE MARK
5504 DCR Direct Conversion Receiver	5504-CGT	5504-CGT

Advanced Information: The Advanced Information data sheet is to be approved for Beta Site and advanced customer information purposes only. It is not intended to replace the electrical specification for the specific device it represents. This document will be updated and converted into a Final (Preliminary Data Sheet) upon completion of Design Engineering Validation. Design Engineering should review this documentation for its accuracy to the definition and the design goals for the product it represents.

No responsibility is assumed by TDK Semiconductor Corporation for use of this product nor for any infringements of patents and trademarks or other rights of third parties resulting from its use. No license is granted under any patents, patent rights or trademarks of TDK Semiconductor Corporation, and the company reserves the right to make changes in specifications at any time without notice. Accordingly, the reader is cautioned to verify that the data sheet is current before placing orders.

Purchase of I²C components of TDK Corporation or one of its sublicensed Associated Companies conveys a license under the Philips I²C Patent Rights to use these components in an I²C system, provided that the system conforms to the I²C Standard Specification as defined by Philips.

TDK Semiconductor Corp., 2642 Michelle Dr., Tustin, CA 92780, (714) 508-8800, FAX (714) 508-8877, <http://www.tsc.tdk.com>