

Features

Fast Switching Speed
 Surface Mount Package Ideally Suited for Automatic Insertion
 For General Purpose Switching Applications
 High Conductance

Mechanical Data

Case: SOT-23, Molded Plastic
 Terminals: Solderable per MIL-STD-202, Method 208
 Polarity: See Diagram
 Weight: 0.008 grams (approx.)

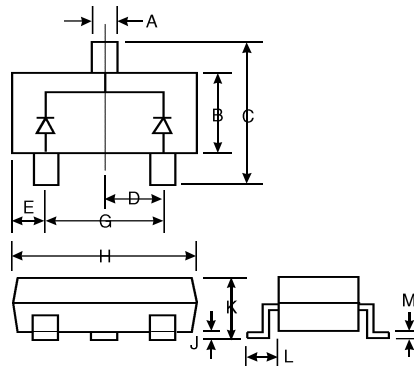

SOT-23		
Dim	Min	Max
A	0.37	0.51
B	1.19	1.40
C	2.10	2.50
D	0.89	1.05
E	0.45	0.61
G	1.78	2.05
H	2.65	3.05
J	0.013	0.15
K	0.89	1.10
L	0.45	0.61
M	0.076	0.178
All Dimensions in mm		

Maximum Ratings @ T_A = 25 C unless otherwise specified

Characteristic	Symbol	BAV70	Unit
Non-Repetitive Peak Reverse Voltage	V _{RM}	100	V
Peak Repetitive Reverse Voltage Working Peak Reverse Voltage DC Blocking Voltage	V _{RRM} V _{RWM} V _R	75	V
RMS Reverse Voltage	V _{R(RMS)}	53	V
Forward Continuous Current (Note 1)	I _{FM}	300	mA
Average Rectified Output Current (Note 1)	I _O	150	mA
Non-Repetitive Peak Forward Surge Current @ t = 1.0 s @ t = 1.0s	I _{FSM}	2.0 1.0	A
Power Dissipation (Note 1)	P _d	350	mW
Thermal Resistance Junction to Ambient Air (Note 1)	R _{JA}	357	K/W
Operating and Storage Temperature Range	T _J , T _{STG}	-65 to +150	C

Electrical Characteristics @ T_A = 25 C unless otherwise specified

Characteristic	Symbol	Min	Max	Unit	Test Condition
Maximum Forward Voltage	V _{FM}		0.715 0.855 1.0 1.25	V	I _F = 1.0mA I _F = 10mA I _F = 50mA I _F = 150mA
Maximum Peak Reverse Current	I _{RM}		2.5 50 30 25	A A A nA	V _R = 75V V _R = 75V, T _j = 150 C V _R = 25V, T _j = 150 C V _R = 20V
Junction Capacitance	C _j		2.0	pF	V _R = 0, f = 1.0MHz
Reverse Recovery Time	t _{rr}		4.0	ns	I _F = I _R = 10mA, I _{rr} = 0.1 x I _R , R _L = 100

Notes: 1. Valid provided that terminals are kept at ambient temperature.

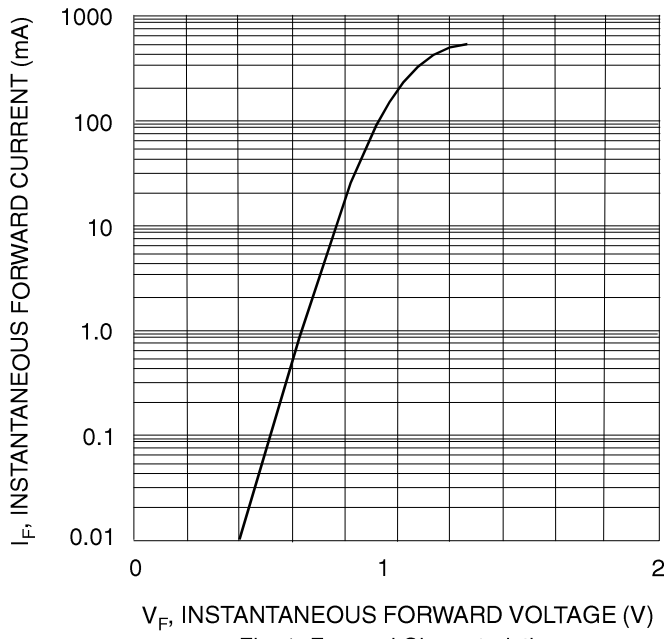

Fig. 1 Forward Characteristics

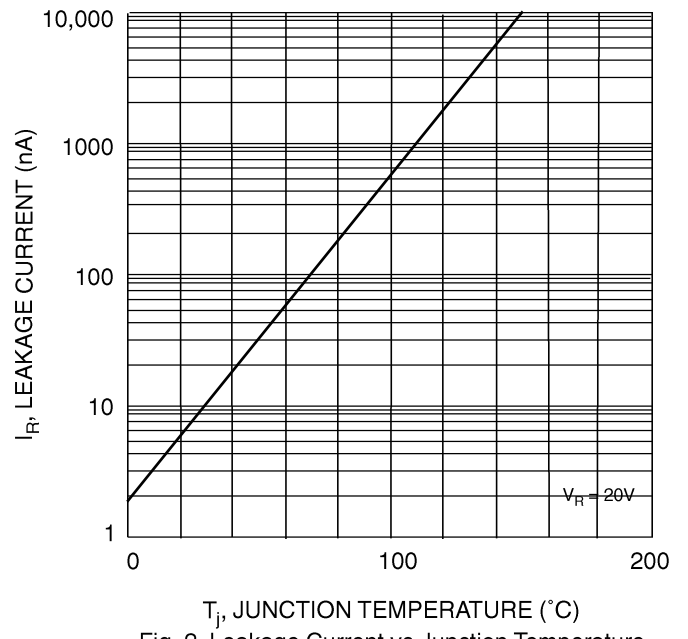

Fig. 2 Leakage Current vs Junction Temperature