

## GaAs/GaAlAs Infrared Emitting Diode in SMT Package

### Description

TSML3700 is an infrared emitting diode in GaAlAs on GaAs technology in a miniature PL-CC-2 SMD package.

It has been designed to meet the increasing demand on optoelectronic devices for surface mounting.

The package consists of a lead frame which is surrounded with a white thermoplast. The reflector inside the package is filled up with clear epoxy.

This new package achieves an improvement of 100% in radiant intensity, compared with the old SOT-23 package.

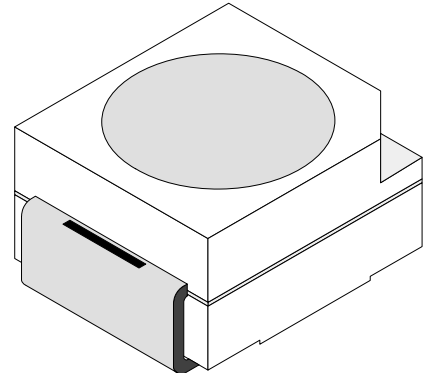

94 8553

### Features

- SMT IRED with extra high radiant power
- Low forward voltage
- Compatible with automatic placement equipment
- EIA and ICE standard package
- Suitable for infrared, vapor phase and wave-solder process
- Available in 8 mm tape
- Suitable for pulse current operation
- Extra wide angle of half intensity  $\varphi = \pm 60^\circ$
- Peak wavelength  $\lambda_p = 925 \text{ nm}$
- High reliability
- Matching to TEMT3700 phototransistor

### Applications

Infrared source in tactile keyboards

IR diode in low space applications

Matching with phototransistor TEMT3700 in reflective sensors

High performance PCB mounted infrared sensors

High power infrared emitter for miniature light barriers

### Absolute Maximum Ratings

$T_{amb} = 25^{\circ}\text{C}$

Parameter	Test Conditions	Symbol	Value	Unit
Reverse Voltage		$V_R$	5	V
Forward Current		$I_F$	100	mA
Peak Forward Current	$t_p/T = 0.5, t_p = 100 \mu\text{s}$	$I_{FM}$	200	mA
Surge Forward Current	$t_p = 100 \mu\text{s}$	$I_{FSM}$	1	A
Power Dissipation		$P_V$	170	mW
Junction Temperature		$T_j$	100	$^{\circ}\text{C}$
Operating Temperature Range		$T_{amb}$	-55...+100	$^{\circ}\text{C}$
Storage Temperature Range		$T_{stg}$	-55...+100	$^{\circ}\text{C}$
Soldering Temperature	$t \leq 10\text{sec}$	$T_{sd}$	260	$^{\circ}\text{C}$
Thermal Resistance Junction/Ambient		$R_{thJA}$	450	K/W

### Basic Characteristics

$T_{amb} = 25^{\circ}\text{C}$

Parameter	Test Conditions	Symbol	Min	Typ	Max	Unit
Forward Voltage	$I_F = 100 \text{ mA}, t_p = 20 \text{ ms}$	$V_F$		1.3	1.7	V
	$I_F = 1 \text{ A}, t_p = 100 \mu\text{s}$	$V_F$		2.2		V
Temp. Coefficient of $V_F$	$I_F = 100\text{mA}$	$TK_{V_F}$		-1.3		mV/K
Reverse Current	$V_R = 5 \text{ V}$	$I_R$			100	$\mu\text{A}$
Junction Capacitance	$V_R = 0 \text{ V}, f = 1 \text{ MHz}, E = 0$	$C_j$		20		pF
Radiant Intensity	$I_F = 100 \text{ mA}, t_p = 20 \text{ ms}$	$I_e$	2.5	7		mW/sr
	$I_F = 1 \text{ A}, t_p = 100 \mu\text{s}$	$I_e$		60		mW/sr
Radiant Power	$I_F = 100 \text{ mA}, t_p = 20 \text{ ms}$	$\phi_e$		32		mW
Temp. Coefficient of $\phi_e$	$I_F = 100 \text{ mA}$	$TK_{\phi_e}$		-0.8		%/K
Angle of Half Intensity		$\varphi$		$\pm 60$		deg
Peak Wavelength	$I_F = 100 \text{ mA}$	$\lambda_p$		925		nm
Spectral Bandwidth	$I_F = 100 \text{ mA}$	$\Delta\lambda$		50		nm
Temp. Coefficient of $\lambda_p$	$I_F = 100 \text{ mA}$	$TK_{\lambda_p}$		0.2		nm/K
Rise Time	$I_F = 20 \text{ mA}$	$t_r$		800		ns
	$I_F = 1 \text{ A}$	$t_r$		500		ns
Fall Time	$I_F = 20 \text{ mA}$	$t_f$		800		ns
	$I_F = 1 \text{ A}$	$t_f$		500		ns

**Typical Characteristics** ( $T_{amb} = 25^{\circ}\text{C}$  unless otherwise specified)

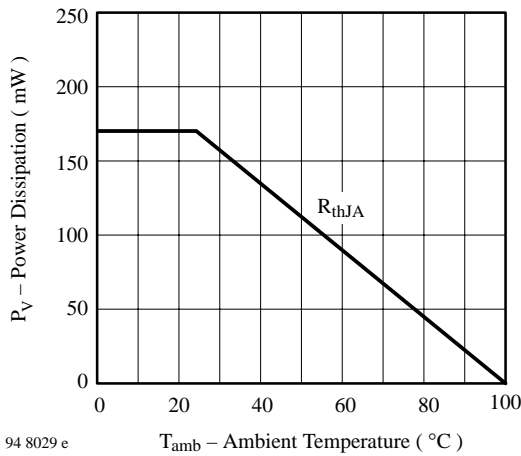

94 8029 e

Figure 1. Power Dissipation vs. Ambient Temperature

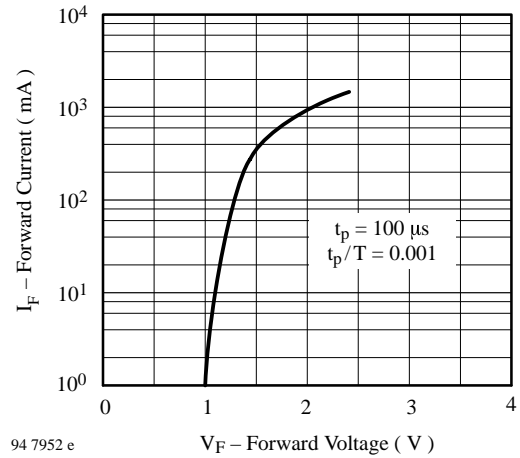

94 7952 e

Figure 4. Forward Current vs. Forward Voltage

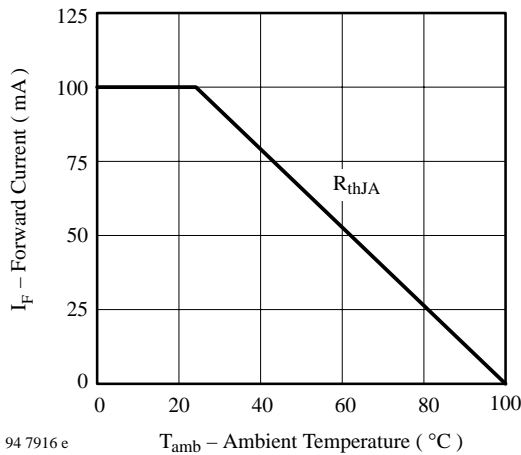

94 7916 e

Figure 2. Forward Current vs. Ambient Temperature

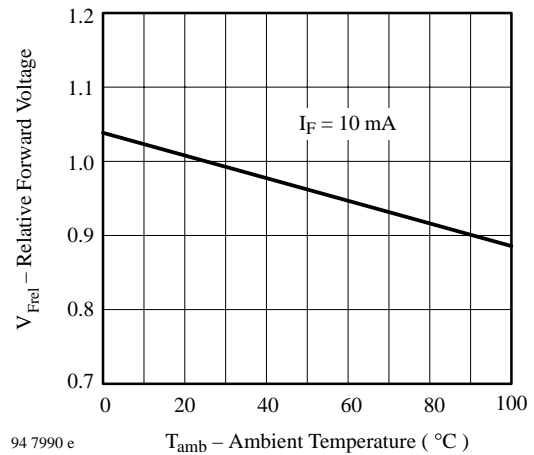

94 7990 e

Figure 5. Relative Forward Voltage vs. Ambient Temperature

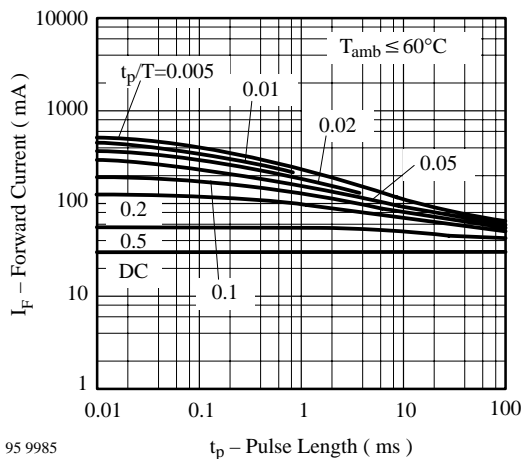

95 9985

Figure 3. Pulse Forward Current vs. Pulse Duration

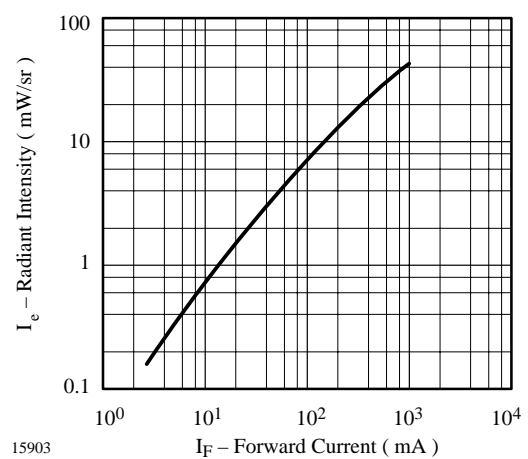

15903

Figure 6. Radiant Intensity vs. Forward Current

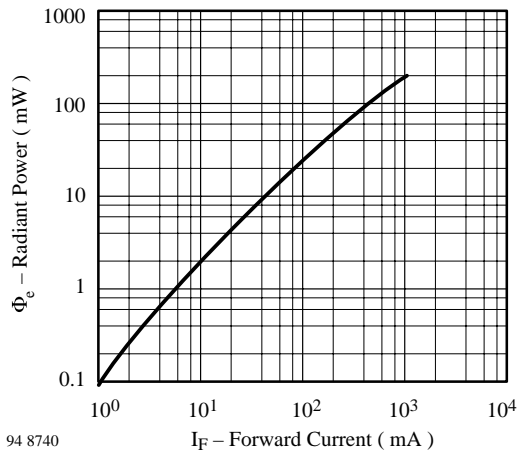

Figure 7. Radiant Power vs. Forward Current

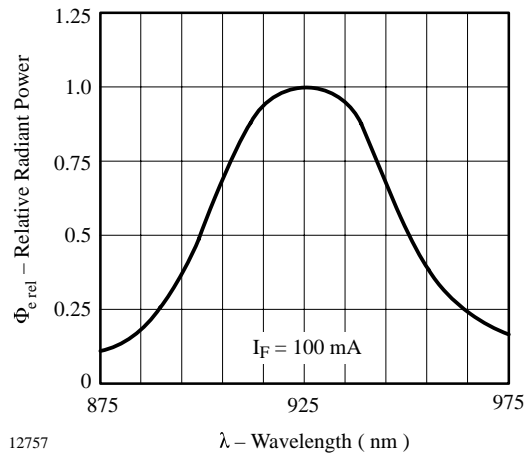

Figure 9. Relative Radiant Power vs. Wavelength

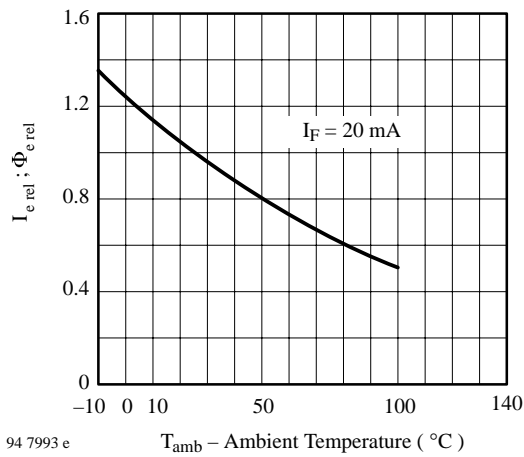

Figure 8. Rel. Radiant Intensity/Power vs. Ambient Temperature

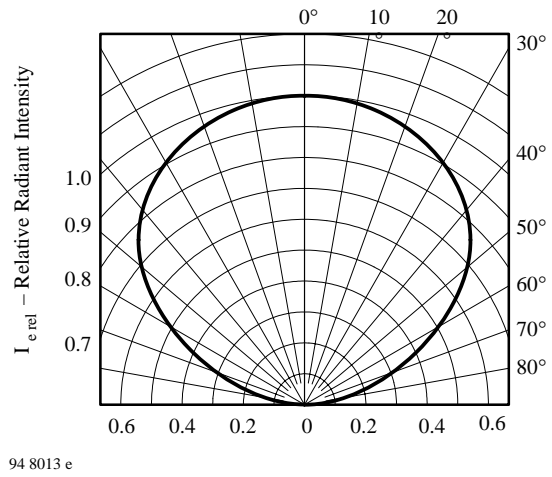
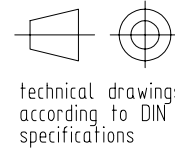
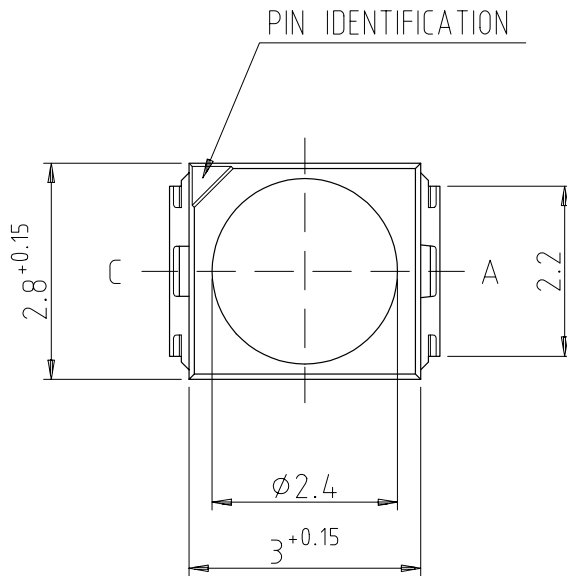
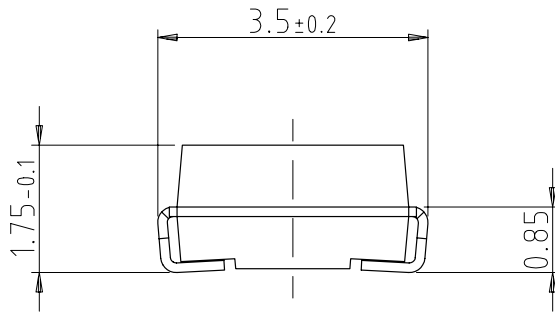

Figure 10. Relative Radiant Intensity vs. Angular Displacement

**Dimensions in mm**



95 11314

### Ozone Depleting Substances Policy Statement

It is the policy of **Vishay Semiconductor GmbH** to

1. Meet all present and future national and international statutory requirements.
2. Regularly and continuously improve the performance of our products, processes, distribution and operating systems with respect to their impact on the health and safety of our employees and the public, as well as their impact on the environment.

It is particular concern to control or eliminate releases of those substances into the atmosphere which are known as ozone depleting substances (ODSs).

The Montreal Protocol (1987) and its London Amendments (1990) intend to severely restrict the use of ODSs and forbid their use within the next ten years. Various national and international initiatives are pressing for an earlier ban on these substances.

**Vishay Semiconductor GmbH** has been able to use its policy of continuous improvements to eliminate the use of ODSs listed in the following documents.

1. Annex A, B and list of transitional substances of the Montreal Protocol and the London Amendments respectively
2. Class I and II ozone depleting substances in the Clean Air Act Amendments of 1990 by the Environmental Protection Agency (EPA) in the USA
3. Council Decision 88/540/EEC and 91/690/EEC Annex A, B and C (transitional substances) respectively.

**Vishay Semiconductor GmbH** can certify that our semiconductors are not manufactured with ozone depleting substances and do not contain such substances.

**We reserve the right to make changes to improve technical design and may do so without further notice.**

Parameters can vary in different applications. All operating parameters must be validated for each customer application by the customer. Should the buyer use Vishay-Telefunken products for any unintended or unauthorized application, the buyer shall indemnify Vishay-Telefunken against all claims, costs, damages, and expenses, arising out of, directly or indirectly, any claim of personal damage, injury or death associated with such unintended or unauthorized use.

Vishay Semiconductor GmbH, P.O.B. 3535, D-74025 Heilbronn, Germany  
Telephone: 49 (0) 7131 67 2831, Fax number: 49 (0) 7131 67 2423