

Transmissive Optical Sensor with Schmitt Trigger Logic Output

Description

This device consists of a transmissive sensor with a 3-pin connector. The operating wavelength is $\lambda = 950 \text{ nm}$. The detector consists of a photologic-IC with Schmitt trigger output.

Applications

- Detection of opaque material, documents etc
- Paper position sensor in copy machines
- Position sensor for shaft encoder

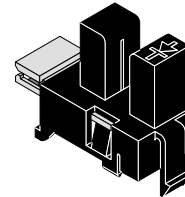

95 10755

Features

- Output: 'LOW' when infrared beam is not interrupted
- Inverter-open collector
- TTL compatible
- Built-in voltage regulator
- Case plastic polycarbonate-protected against ambient light
- No adjustment necessary
- Applicable connector Molex 5267-NA (Serie) (order number: 22-03-5035)
- Aperture size 0.5 mm

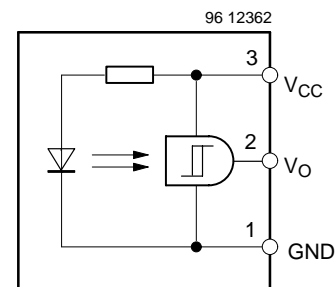

Pin connection

Handling Precautions

Connect a capacitor C of 100 nF between V_{S1} and ground in order to stabilize power supply voltage!

Order Instruction

Ordering Code	Resolution (mm) / Aperture (mm)	Remarks
TCYS5201	/ 0.5	

Absolute Maximum Ratings ($T_{amb} = 25^{\circ}\text{C}$)

Parameter	Test Conditions	Symbol	Value	Unit
Supply voltage		V_S	16	V
Output voltage		V_O	30	V
Low level output current		I_{OL}	20	mA
Operation temperature range		T_{amb}	-25 to +85	$^{\circ}\text{C}$
Storage temperature range		T_{stg}	-40 to +100	$^{\circ}\text{C}$

Electrical Characteristics ($T_{amb} = 25^{\circ}\text{C}$)

Parameter	Test Conditions	Symbol	Min.	Typ.	Max.	Unit
Supply voltage range		V_S	4.5		5.5	V
High level supply current	$V_S = 5\text{ V}^1$	I_S		15	30	mA
Low level supply current	$V_S = 5\text{ V}^2$	I_S		15	30	mA
High level output voltage	$V_S = 5\text{ V}, R_L = 1\text{ k}\Omega^1$	V_{OH}	4.5			V
Low level output voltage	$V_S = 5\text{ V}, I_{OL} = 16\text{ mA}^2$	V_{OL}		0.18	0.35	V
Switching frequency	$V_S = 5\text{ V}, R_L = 47\text{ k}\Omega$	f			3	KHz

¹⁾ Infrared beam interrupted
²⁾ Infrared beam not interrupted

Note: Operating conditions are stabilized after 100 μs of supply voltage turn on.

Switching Characteristics

Parameter	Test Conditions	Symbol	Typ.	Unit
Rise time	$V_{S1} = 5\text{ V}, R_L = 1\text{ k}\Omega$ (see figure 1)	t_r	50.0	ns
Fall time		t_f	20.0	ns

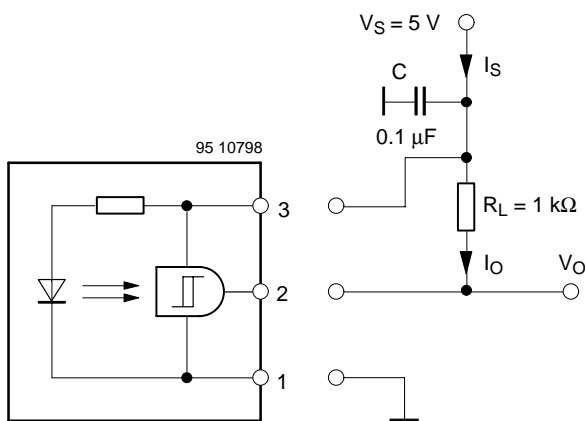

Figure 1. Test circuit and pin connection

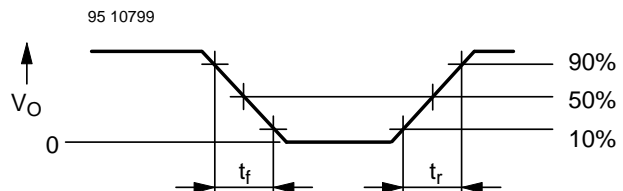

Figure 2. Pulse diagram

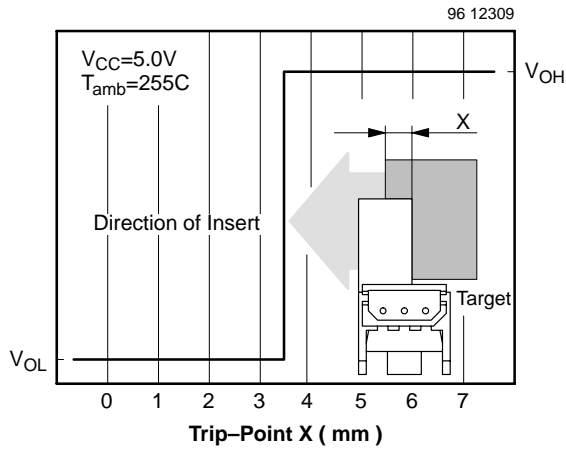

Figure 3. Trip point characteristic

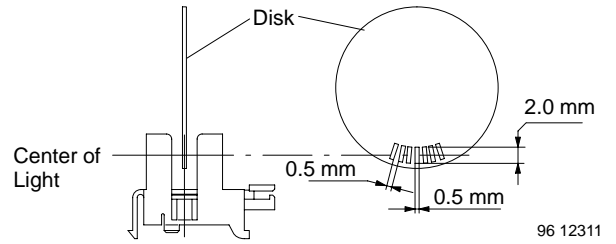

Figure 4. Frequency response

Typical Characteristics ($T_{amb} = 25^{\circ}C$, unless otherwise specified)

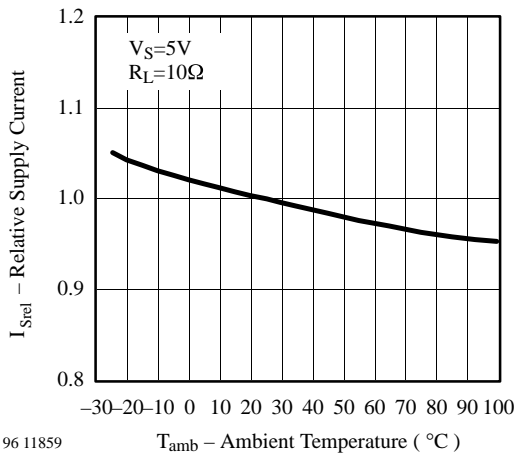

Figure 5. Relative Supply Current vs. Ambient Temperature

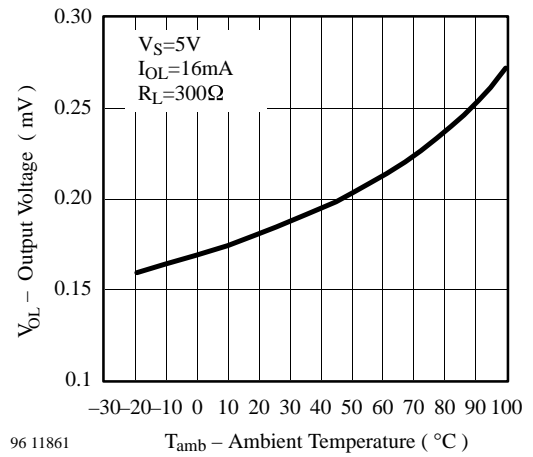

Figure 7. Output Voltage vs. Ambient Temperature

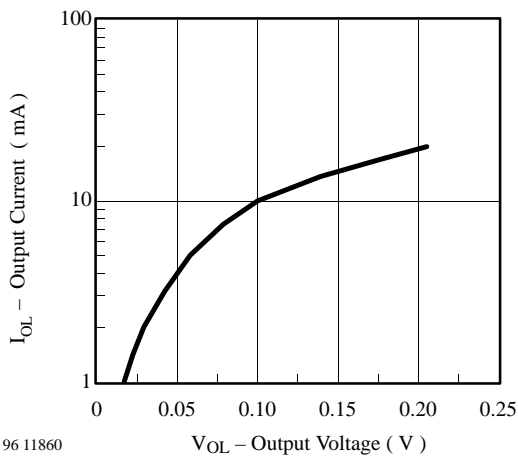

Figure 6. Output Current vs. Output Voltage

TCYS5201

Vishay Telefunken



Dimensions of TCYS5201 in mm

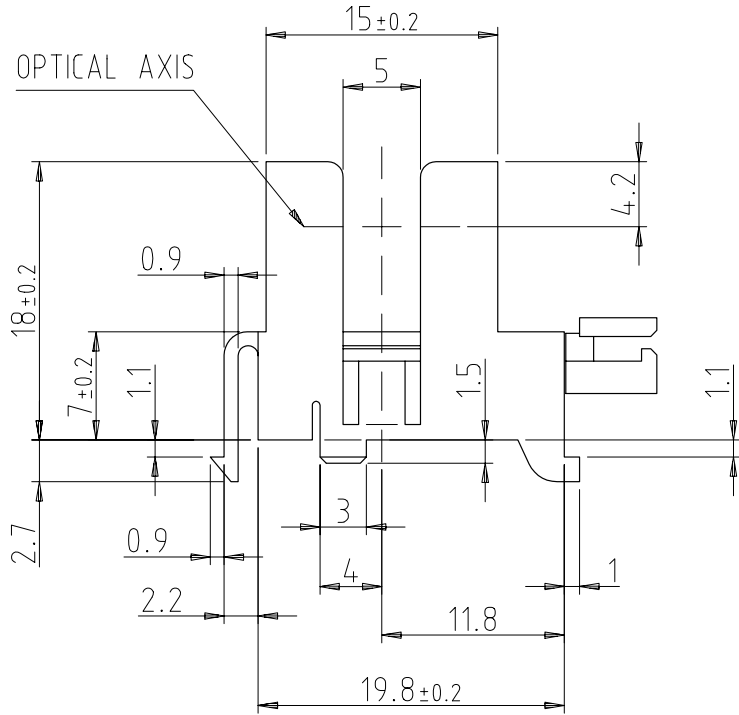
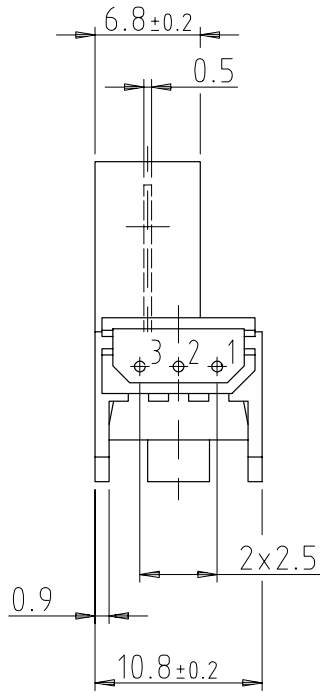

- 1 = GND
- 2 = V_O
- 3 = V_{CC}

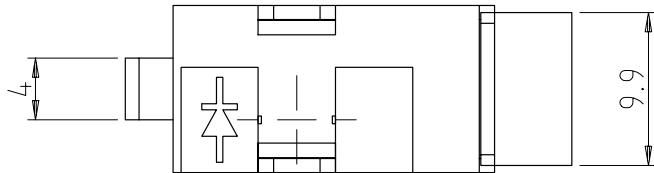

weight: ca. 1.01g

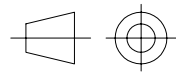

technical drawings according to DIN specifications

96 12101



Ozone Depleting Substances Policy Statement

It is the policy of **Vishay Semiconductor GmbH** to

1. Meet all present and future national and international statutory requirements.
2. Regularly and continuously improve the performance of our products, processes, distribution and operating systems with respect to their impact on the health and safety of our employees and the public, as well as their impact on the environment.

It is particular concern to control or eliminate releases of those substances into the atmosphere which are known as ozone depleting substances (ODSs).

The Montreal Protocol (1987) and its London Amendments (1990) intend to severely restrict the use of ODSs and forbid their use within the next ten years. Various national and international initiatives are pressing for an earlier ban on these substances.

Vishay Semiconductor GmbH has been able to use its policy of continuous improvements to eliminate the use of ODSs listed in the following documents.

1. Annex A, B and list of transitional substances of the Montreal Protocol and the London Amendments respectively
2. Class I and II ozone depleting substances in the Clean Air Act Amendments of 1990 by the Environmental Protection Agency (EPA) in the USA
3. Council Decision 88/540/EEC and 91/690/EEC Annex A, B and C (transitional substances) respectively.

Vishay Semiconductor GmbH can certify that our semiconductors are not manufactured with ozone depleting substances and do not contain such substances.

We reserve the right to make changes to improve technical design and may do so without further notice.

Parameters can vary in different applications. All operating parameters must be validated for each customer application by the customer. Should the buyer use Vishay Telefunken products for any unintended or unauthorized application, the buyer shall indemnify Vishay Telefunken against all claims, costs, damages, and expenses, arising out of, directly or indirectly, any claim of personal damage, injury or death associated with such unintended or unauthorized use.

Vishay Semiconductor GmbH, P.O.B. 3535, D-74025 Heilbronn, Germany
Telephone: 49 (0) 7131 67 2831, Fax number: 49 (0) 7131 67 2423