

# TLV5613

## 2.7 V TO 5.5 V 12-BIT PARALLEL DIGITAL-TO-ANALOG CONVERTER WITH POWER DOWN

SLAS174A – DECEMBER 1997 – REVISED JULY 1998

- 12-Bit Voltage Output DAC
- Single Supply 2.7-V to 5.5-V Operation
- Separate Analog and Digital Supplies
- $\pm 0.4$  LSB Differential Nonlinearity (DNL),  $\pm 1.5$  LSB Integral Nonlinearity (INL)
- Programmable Settling Time vs Power Consumption:
  - 1  $\mu$ s/4.2 mW in Fast Mode,
  - 3.5  $\mu$ s/1.2 mW in Slow Mode
- 8-Bit  $\mu$ Controller Compatible Interface (8+4 Bit)
- Power-Down Mode (50 nW)
- Rail-to-Rail Output Buffer
- Synchronous or Asynchronous Update
- Monotonic Over Temperature

### applications

- Digital Servo Control Loops
- Battery Powered Test Instruments
- Digital Offset and Gain Adjustment
- Industrial Process Control
- Speech Synthesis
- Machine and Motion Control Devices
- Mass Storage Devices

### description

The TLV5613 is a 12-bit voltage output digital-to-analog converter (DAC) with a 8-bit microcontroller compatible parallel interface. The 8 LSBs, the 4 MSBs and 3 control bits are written using three different addresses. Developed for a wide range of supply voltages, the TLV5613 can be operated from 2.7 V to 5.5 V.

The resistor string output voltage is buffered by a x2 gain rail-to-rail output buffer. The buffer features a Class A (slow mode: AB) output stage to improve stability and reduce settling time. The programmable settling time of the DAC allows the designer to optimize speed versus power dissipation. The settling time can be chosen by the control bits within the 16-bit data word.

Implemented with a CMOS process, the device is designed for single supply operation from 2.7 V to 5.5 V. It is available in 20 pin SOIC in standard commercial and industrial temperature ranges.

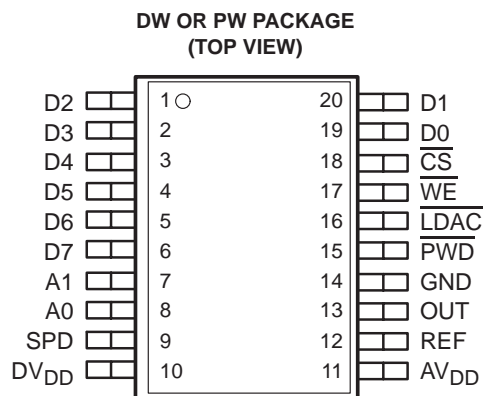

### AVAILABLE OPTIONS

T <sub>A</sub>	PACKAGE	
	SMALL OUTLINE (DW)	TSSOP (PW)
0°C to 70°C	TLV5613CDW	TLV5613CPW
-40°C to 85°C	TLV5613IDW	TLV5613IPW



Please be aware that an important notice concerning availability, standard warranty, and use in critical applications of Texas Instruments semiconductor products and disclaimers thereto appears at the end of this data sheet.

PRODUCTION DATA information is current as of publication date. Products conform to specifications per the terms of Texas Instruments standard warranty. Production processing does not necessarily include testing of all parameters.

**TEXAS  
INSTRUMENTS**

POST OFFICE BOX 655303 • DALLAS, TEXAS 75265

Copyright © 1998, Texas Instruments Incorporated

# TLV5613

## 2.7 V TO 5.5 V 12-BIT PARALLEL DIGITAL-TO-ANALOG CONVERTER WITH POWER DOWN

SLAS174A – DECEMBER 1997 – REVISED JULY 1998

### functional block diagram

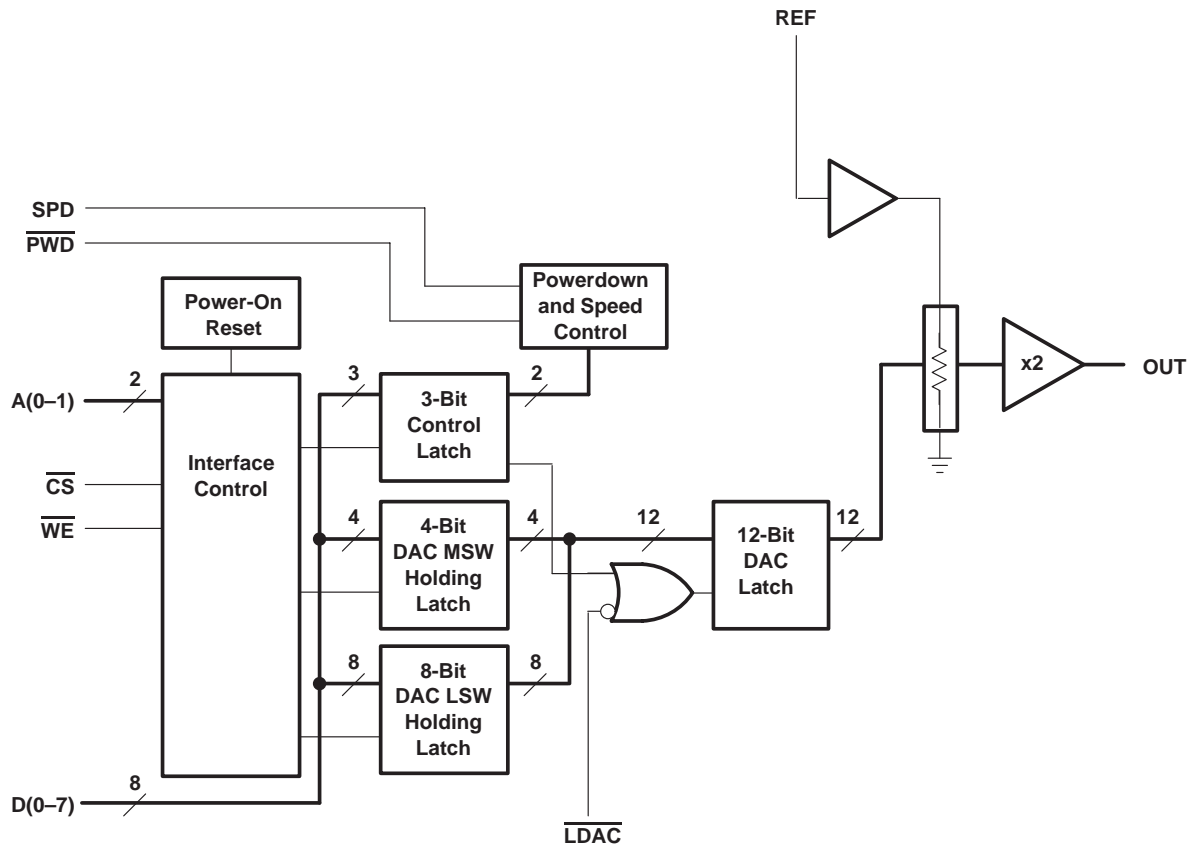

### Terminal Functions

TERMINAL NAME	NO.	I/O	DESCRIPTION
AV <sub>DD</sub>	11		Analog positive power supply
A0	8	I	Address input
A1	7	I	Address input
CS	18	I	Chip select. Digital input active low, used to enable/disable inputs
DV <sub>DD</sub>	10		Digital positive power supply
D0 (LSB) – D7 (MSB)	1–6, 19, 20	I	Data input
LDAC	16	I	Load DAC. Digital input active low, used to load DAC output
OUT	13	O	DAC analog voltage output
PWD	15	I	Power down. Digital input active low
REF	12	I	Analog reference voltage input
SPD	9	I	Speed select. Digital input
GND	14		Ground
WE	17	I	Write enable. Digital input active low, used to latch data

# TLV5613

## 2.7 V TO 5.5 V 12-BIT PARALLEL DIGITAL-TO-ANALOG CONVERTER WITH POWER DOWN

SLAS174A – DECEMBER 1997 – REVISED JULY 1998

### absolute maximum ratings over operating free-air temperature range (unless otherwise noted)<sup>†</sup>

Supply voltage (DV <sub>DD</sub> , AV <sub>DD</sub> to GND)	7 V
Supply voltage difference, AV <sub>DD</sub> to DV <sub>DD</sub>	– 2.8 V to 2.8 V
Reference input voltage range	– 0.3 V to AV <sub>DD</sub> + 0.3 V
Digital input voltage range to GND	– 0.3 V to DV <sub>DD</sub> + 0.3 V
Operating free-air temperature range, T <sub>A</sub> : TLV5613C	0°C to 70°C
TLV5613I	–40°C to 85°C
Storage temperature range, T <sub>stg</sub>	–65°C to 150°C
Lead temperature 1,6 mm (1/16 inch) from case for 10 seconds	260°C

<sup>†</sup> Stresses beyond those listed under “absolute maximum ratings” may cause permanent damage to the device. These are stress ratings only, and functional operation of the device at these or any other conditions beyond those indicated under “recommended operating conditions” is not implied. Exposure to absolute-maximum-rated conditions for extended periods may affect device reliability.

### recommended operating conditions

		MIN	NOM	MAX	UNIT
Supply voltage, V <sub>DD</sub>	5-V Supply	4.5	5	5.5	V
	3-V Supply	2.7	3	3.3	
Supply voltage difference, ΔV <sub>DD</sub> = AV <sub>DD</sub> – DV <sub>DD</sub>		–2.8	0	2.8	V
Power on reset, POR		0.55		2	V
High-level digital input voltage, V <sub>IH</sub>	DV <sub>DD</sub> = 2.7 V to 5.5 V	2			V
Low-level digital input voltage, V <sub>IL</sub>	DV <sub>DD</sub> = 2.7 V to 5.5 V			0.8	V
Reference voltage, V <sub>ref</sub> to REFIN terminal	5-V Supply (see Note 1)	GND	2.048	AV <sub>DD</sub> –1.5	V
	3-V Supply (see Note 1)	GND	1.024	AV <sub>DD</sub> –1.5	
Load resistance, R <sub>L</sub>		2			kΩ
Load capacitance, C <sub>L</sub>				100	pF
Operating free-air temperature, T <sub>A</sub>	TLV5613C	0		70	°C
	TLV5613I	–40		85	°C

NOTE 1: Due to the x2 output buffer, a reference input voltage  $\geq (V_{DD} - 0.4)/2$  causes clipping of the transfer function.



# TLV5613

## 2.7 V TO 5.5 V 12-BIT PARALLEL DIGITAL-TO-ANALOG CONVERTER WITH POWER DOWN

SLAS174A – DECEMBER 1997 – REVISED JULY 1998

electrical characteristics over recommended operating free-air temperature range, supply voltages, and reference voltages (unless otherwise noted)

### power supply

PARAMETER		TEST CONDITIONS		MIN	TYP	MAX	UNIT
I <sub>DD</sub>	Power supply current	No load, All inputs = GND or DV <sub>DD</sub> , DAC latch = 0x800	V <sub>DD</sub> = 5 V	Fast	1.6	3	mA
				Slow	0.5	1.3	mA
			V <sub>DD</sub> = 3 V	Fast	1.4	2.7	mA
				Slow	0.4	1.1	mA
Power down supply current		See Figure 14		0.01	10	μA	
PSRR	Power supply rejection ratio	Zero scale,	See Note 2	-65		dB	
		Full scale,	See Note 3	-65			

NOTES: 2. Power supply rejection ratio at zero scale is measured by varying AV<sub>DD</sub> and is given by:

$$PSRR = 20 \log [(E_{ZS}(AV_{DDmax}) - E_{ZS}(AV_{DDmin})) / AV_{DDmax}]$$

3. Power supply rejection ratio at full scale is measured by varying AV<sub>DD</sub> and is given by:

$$PSRR = 20 \log [(E_G(AV_{DDmax}) - E_G(AV_{DDmin})) / AV_{DDmax}]$$

### static DAC specifications

PARAMETER		TEST CONDITIONS		MIN	TYP	MAX	UNIT
Resolution		V <sub>ref</sub> (REFIN) = 2.048 V, 1.024 V		12			bits
Integral nonlinearity (INL), end point adjusted		V <sub>ref</sub> (REFIN) = 2.048 V, 1.024 V, See Note 4		±1.5		±4	LSB
Differential nonlinearity (DNL)		V <sub>ref</sub> (REFIN) = 2.048 V, 1.024 V, See Note 5		±0.4		±1	LSB
E <sub>ZS</sub>	Zero-scale error (offset error at zero scale)	V <sub>ref</sub> (REFIN) = 2.048 V, 1.024 V, See Note 6		±3		±20	mV
Zero-scale-error temperature coefficient		V <sub>ref</sub> (REFIN) = 2.048 V, 1.024 V, See Note 7		3			ppm/°C
E <sub>G</sub>	Gain error	V <sub>ref</sub> (REFIN) = 2.048 V, 1.024 V, See Note 8		±0.25		±0.5	% of FS voltage
Gain error temperature coefficient		V <sub>ref</sub> (REFIN) = 2.048 V, 1.024 V, See Note 9		1			ppm/°C

NOTES: 4. The relative accuracy or integral nonlinearity (INL) sometimes referred to as linearity error, is the maximum deviation of the output from the line between zero and full scale excluding the effects of zero code and full-scale errors.

5. The differential nonlinearity (DNL) sometimes referred to as differential error, is the difference between the measured and ideal 1 LSB amplitude change of any two adjacent codes. Monotonic means the output voltage changes in the same direction (or remains constant) as a change in the digital input code.

6. Zero-scale error is the deviation from zero voltage output when the digital input code is zero.

7. Zero-scale-error temperature coefficient is given by:  $E_{ZS} TC = [E_{ZS}(T_{max}) - E_{ZS}(T_{min})] / V_{ref} \times 10^6 / (T_{max} - T_{min})$ .

8. Gain error is the deviation from the ideal output (V<sub>ref</sub> - 1 LSB) with an output load of 10 kΩ excluding the effects of the zero-error.

9. Gain temperature coefficient is given by:  $E_G TC = [E_G(T_{max}) - E_G(T_{min})] / V_{ref} \times 10^6 / (T_{max} - T_{min})$ .

### output specifications

PARAMETER		TEST CONDITIONS		MIN	TYP	MAX	UNIT
V <sub>O</sub>	Output voltage	R <sub>L</sub> = 10 kΩ		0		AV <sub>DD</sub> -0.4	V
Output load regulation accuracy		V <sub>O</sub> (OUT) = 4.096 V,	R <sub>L</sub> = 2 kΩ,	0.1		0.29	% of FS voltage
I <sub>OSC(source)</sub>	Output short circuit source current	V <sub>O</sub> (OUT) = 0 V, input all 1s	AV <sub>DD</sub> = 5 V	-100			mA
			AV <sub>DD</sub> = 3 V	-25			
I <sub>OSC(sink)</sub>	Output short circuit sink current	R <sub>L</sub> = 100 Ω, input all 1s	AV <sub>DD</sub> = 5 V	-10			mA
			AV <sub>DD</sub> = 3 V	-10			



POST OFFICE BOX 655303 • DALLAS, TEXAS 75265

# TLV5613

## 2.7 V TO 5.5 V 12-BIT PARALLEL DIGITAL-TO-ANALOG CONVERTER WITH POWER DOWN

SLAS174A – DECEMBER 1997 – REVISED JULY 1998

**electrical characteristics over recommended operating free-air temperature range, supply voltages, and reference voltages (unless otherwise noted)**

### reference input (REFIN)

PARAMETER	TEST CONDITIONS	MIN	TYP	MAX	UNIT
V <sub>ref</sub> Input voltage reference	See Note 10	0		AV <sub>DD</sub> -1.5	V
R <sub>i</sub> Input resistance			10		MΩ
C <sub>i</sub> Input capacitance			5		pF
Reference input bandwidth	REF = 0.2 V <sub>pp</sub> + 1.024 V dc	Fast mode	1.6		MHz
		Slow mode	1		MHz
Reference feed through	REF = 1 V <sub>pp</sub> at 1 kHz + 1.024 V dc, See Note 10		-60		dB

NOTES: 10. Reference feedthrough is measured at the DAC output with an input code = 0x000.

### digital inputs

PARAMETER	TEST CONDITIONS	MIN	TYP	MAX	UNIT
I <sub>IH</sub> High-level digital input current	V <sub>I</sub> = DV <sub>DD</sub>			1	μA
I <sub>IL</sub> Low-level digital input current	V <sub>I</sub> = 0 V	-1			μA
C <sub>i</sub> Input capacitance			8		pF

**operating characteristics over recommended operating free-air temperature range, supply voltages, and reference voltages (unless otherwise noted)**

### analog output dynamic performance

PARAMETER	TEST CONDITIONS	MIN	TYP	MAX	UNIT
t <sub>s</sub> (FS) Output settling time, full scale	R <sub>L</sub> = 10 kΩ, See Note 11 C <sub>L</sub> = 100 pF,	Fast	1	3	μs
		Slow	3.5	7	
t <sub>s</sub> (CC) Output settling time, code-to-code	R <sub>L</sub> = 10 kΩ, See Note 12 C <sub>L</sub> = 100 pF,	Fast	0.5	1.5	μs
		Slow	1	2	
SR Slew rate	R <sub>L</sub> = 10 kΩ, See Note 13 C <sub>L</sub> = 100 pF,	Fast	8		V/μs
		Slow	1.5		
Glitch energy	Code-to-code transition		1		nV-s
S/N Signal-to-noise	f <sub>s</sub> = 480 KSPS, f <sub>out</sub> = 1 kHz, R <sub>L</sub> = 10 k, C <sub>L</sub> = 100 pF		65	78	dB
S/(N+D) Signal-to-noise + distortion			58	69	
THD Total harmonic distortion			-68	-60	
Spurious free dynamic range			60	72	

NOTES: 11. Settling time is the time for the output signal to remain within ±0.5 LSB of the final measured value for a digital input code change of 0x020 to 0x3FF or 0x3FF to 0x020.

12. Settling time is the time for the output signal to remain within ± 0.5 LSB of the final measured value for a digital input code change of one count. The max time applies to code changes near zero scale or full scale.

13. Slew rate determines the time it takes for a change of the DAC output from 10% to 90% full-scale voltage.



**TLV5613**  
**2.7 V TO 5.5 V 12-BIT PARALLEL DIGITAL-TO-ANALOG CONVERTER**  
**WITH POWER DOWN**

SLAS174A – DECEMBER 1997 – REVISED JULY 1998

**timing requirements**

**digital inputs**

		MIN	NOM	MAX	UNIT
$t_{su}(D)$	Setup time, data ready before positive $\overline{WE}$ edge	9			ns
$t_{su}(CS-WE)$	Setup time, $\overline{CS}$ low before positive $\overline{WE}$ edge	13			ns
$t_{su}(A)$	Setup time, address bits A0, A1	17			ns
$t_h(D)$	Hold time, data held after positive $\overline{WE}$ edge	0			ns
$t_{su}(WE-LD)$	Setup time, positive $\overline{WE}$ edge before $\overline{LDAC}$ low	0			ns
$t_w(WE)$	Pulse duration, $\overline{WE}$ high	10			ns
$t_w(LD)$	Pulse duration, $\overline{LDAC}$ low	10			$\mu s$

**PARAMETER MEASUREMENT INFORMATION**

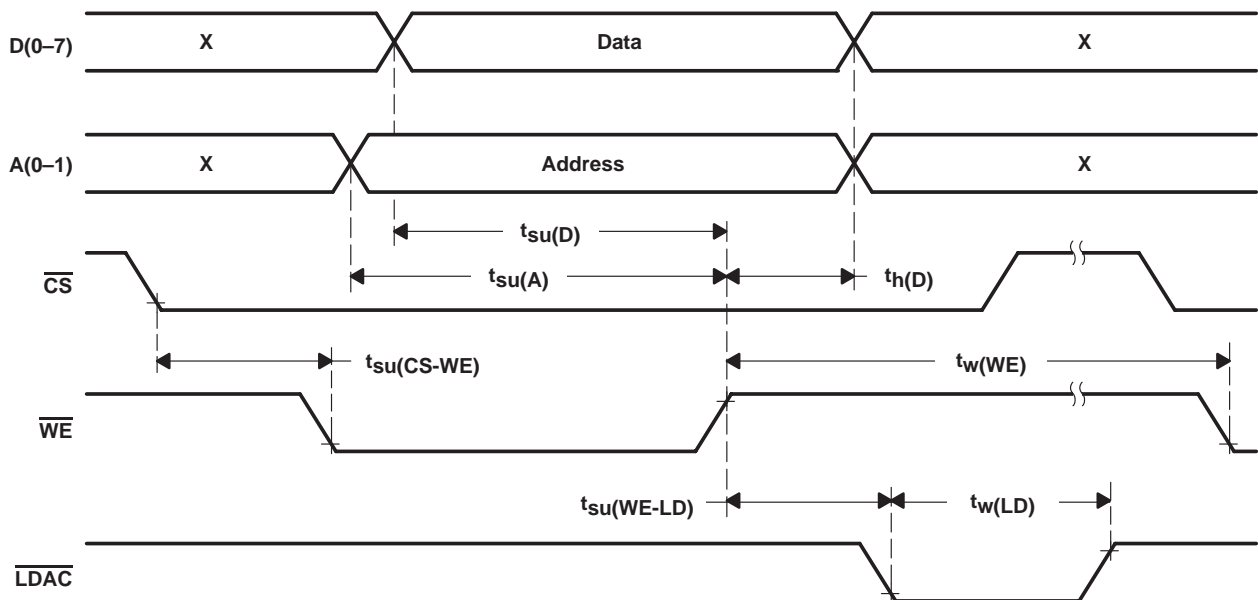
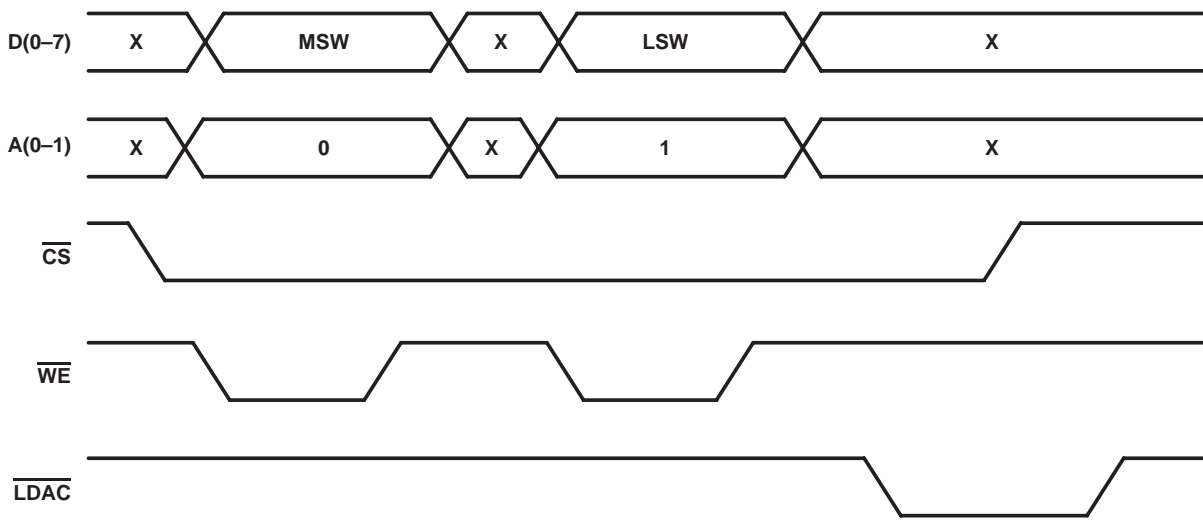

**Figure 1. Timing Diagram**

TLV5613  
**2.7 V TO 5.5 V 12-BIT PARALLEL DIGITAL-TO-ANALOG CONVERTER  
 WITH POWER DOWN**

SLAS174A – DECEMBER 1997 – REVISED JULY 1998

**PARAMETER MEASUREMENT INFORMATION**



**Figure 2. Example of a Complete Write Cycle Using  $\overline{\text{LDAC}}$  to Update the DAC**

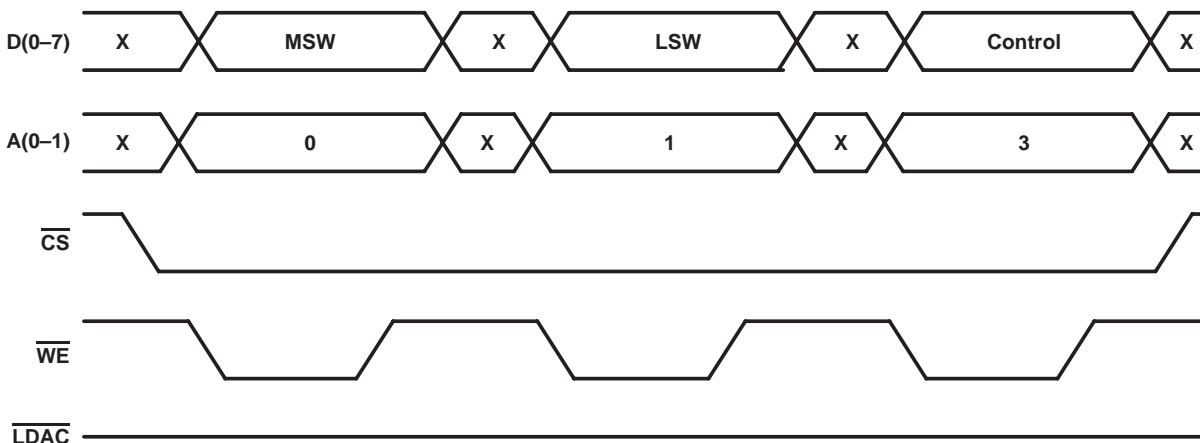

**Figure 3. Example of a Complete Write Cycle Using the Control Word to Update the DAC**

**TLV5613**  
**2.7 V TO 5.5 V 12-BIT PARALLEL DIGITAL-TO-ANALOG CONVERTER**  
**WITH POWER DOWN**

SLAS174A – DECEMBER 1997 – REVISED JULY 1998

**TYPICAL CHARACTERISTICS**

**MAXIMUM OUTPUT VOLTAGE  
 VS  
 LOAD**

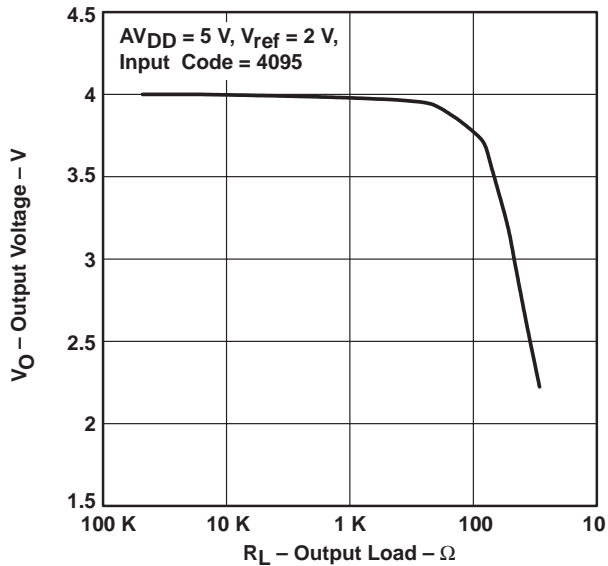

**Figure 4**

**MAXIMUM OUTPUT VOLTAGE  
 VS  
 LOAD**

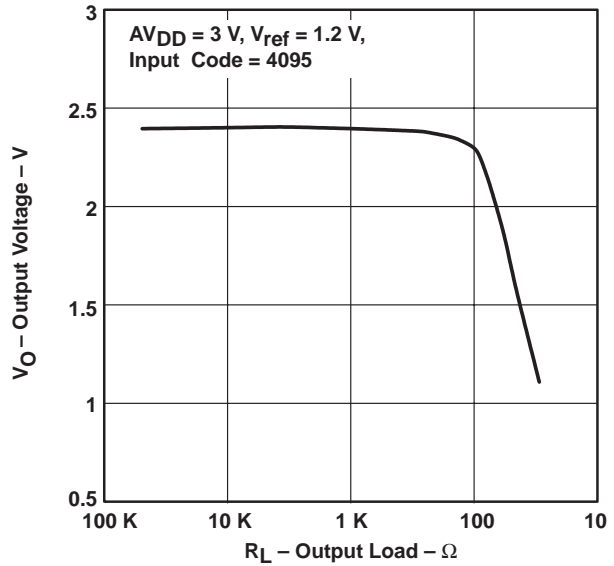

**Figure 5**

**TOTAL HARMONIC DISTORTION  
 VS  
 LOAD**

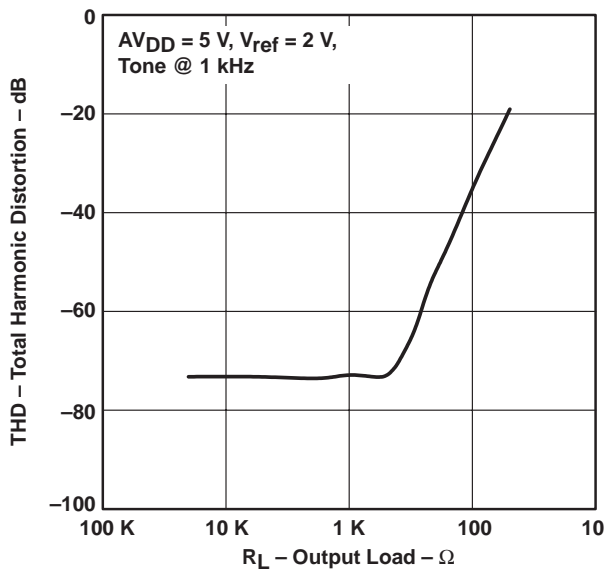

**Figure 6**

**TOTAL HARMONIC DISTORTION  
 VS  
 LOAD**

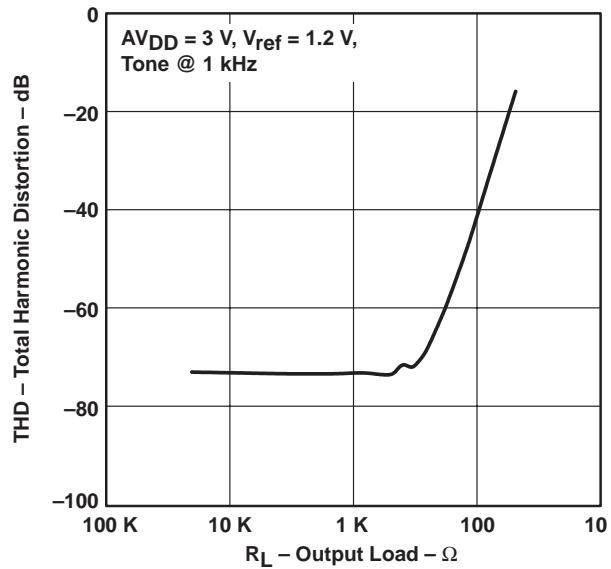

**Figure 7**





TLV5613  
**2.7 V TO 5.5 V 12-BIT PARALLEL DIGITAL-TO-ANALOG CONVERTER  
 WITH POWER DOWN**

SLAS174A – DECEMBER 1997 – REVISED JULY 1998

**TYPICAL CHARACTERISTICS**

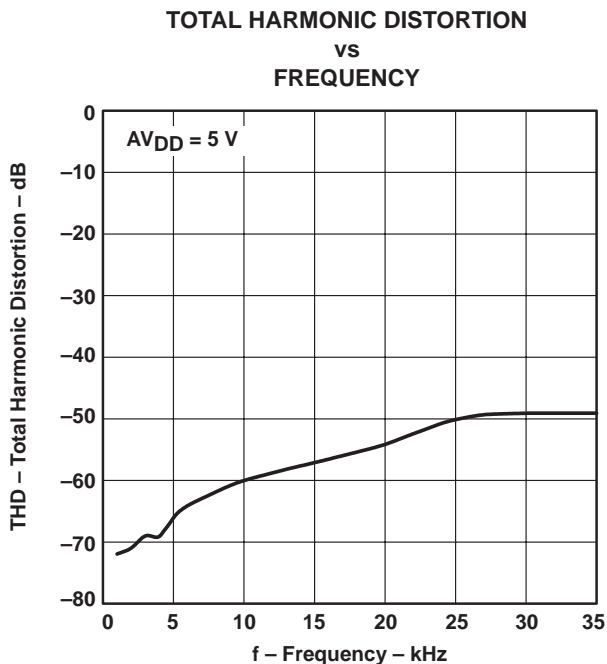

Figure 8

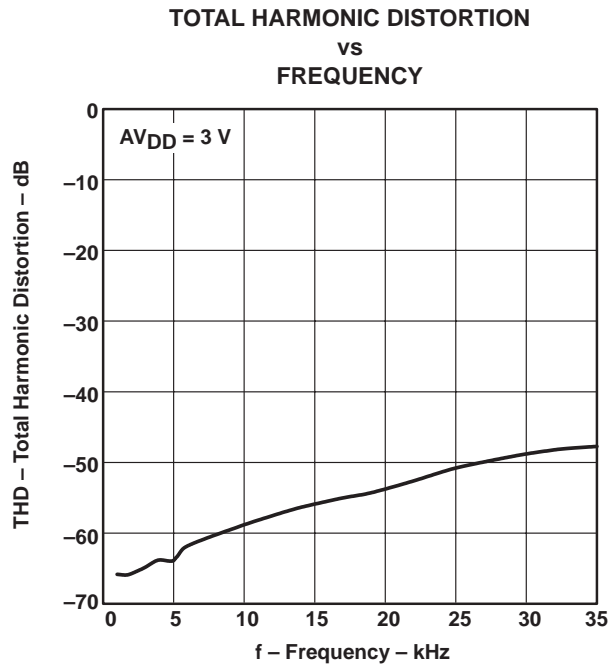

Figure 9

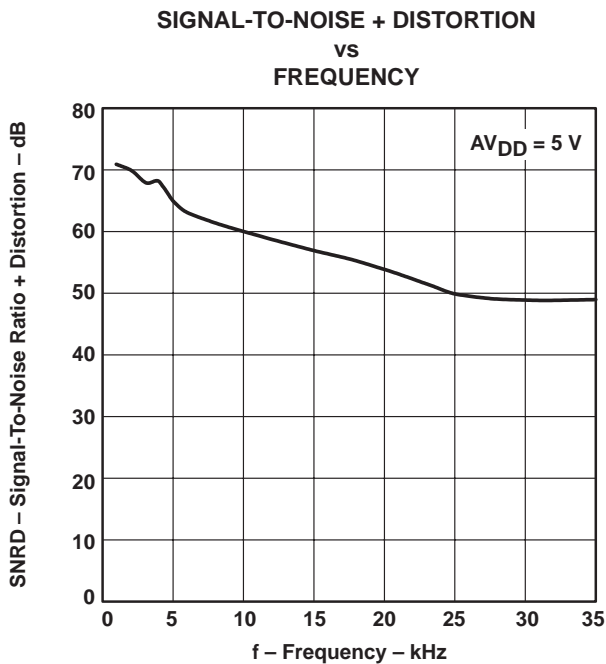

Figure 10

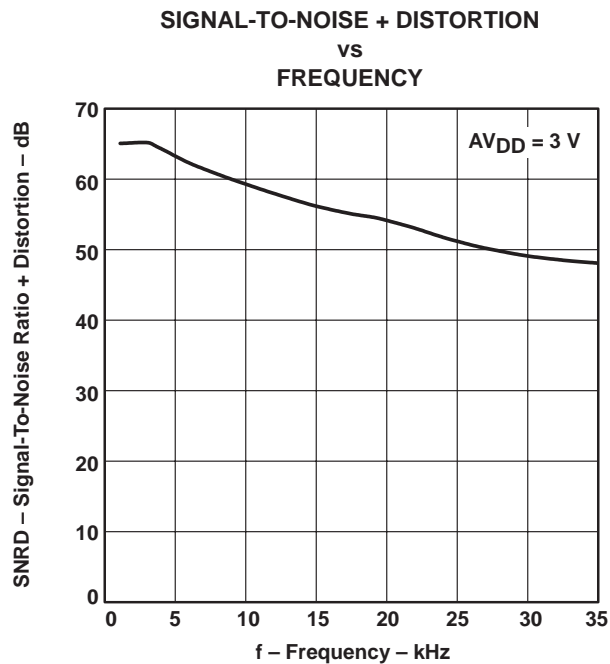

Figure 11



**TLV5613**  
**2.7 V TO 5.5 V 12-BIT PARALLEL DIGITAL-TO-ANALOG CONVERTER**  
**WITH POWER DOWN**

SLAS174A – DECEMBER 1997 – REVISED JULY 1998

**TYPICAL CHARACTERISTICS**

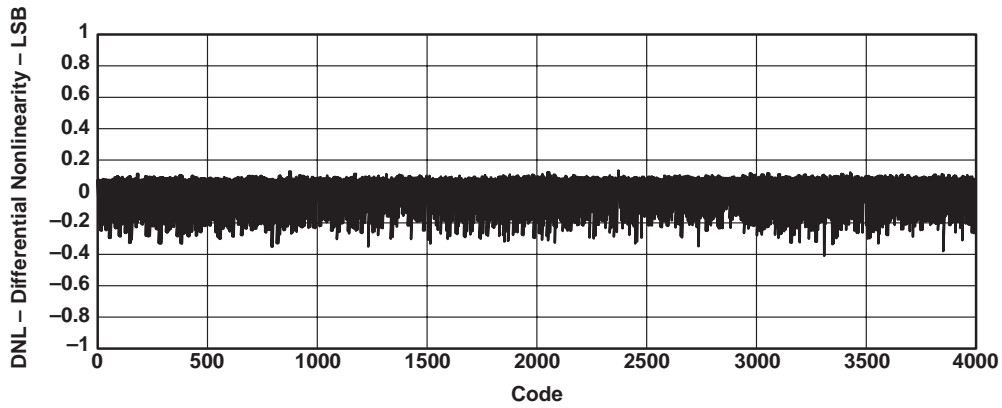

**Figure 12. Differential Nonlinearity**

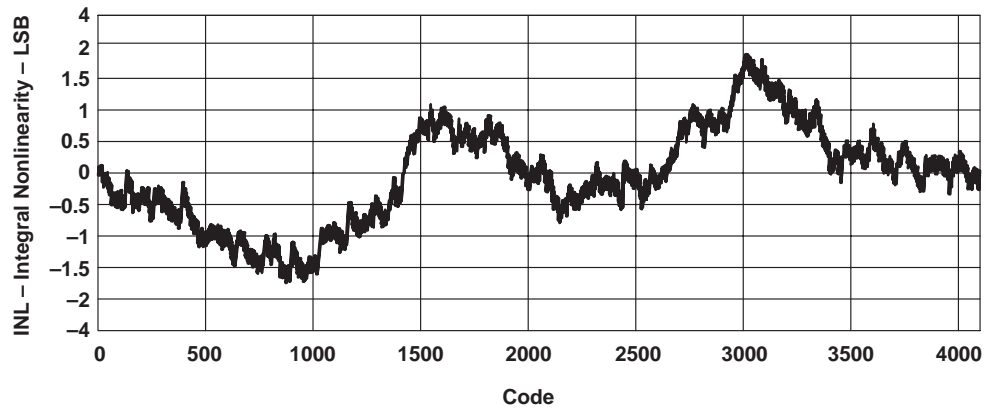

**Figure 13. Integral Nonlinearity**

TLV5613  
**2.7 V TO 5.5 V 12-BIT PARALLEL DIGITAL-TO-ANALOG CONVERTER  
 WITH POWER DOWN**

SLAS174A – DECEMBER 1997 – REVISED JULY 1998

**TYPICAL CHARACTERISTICS**

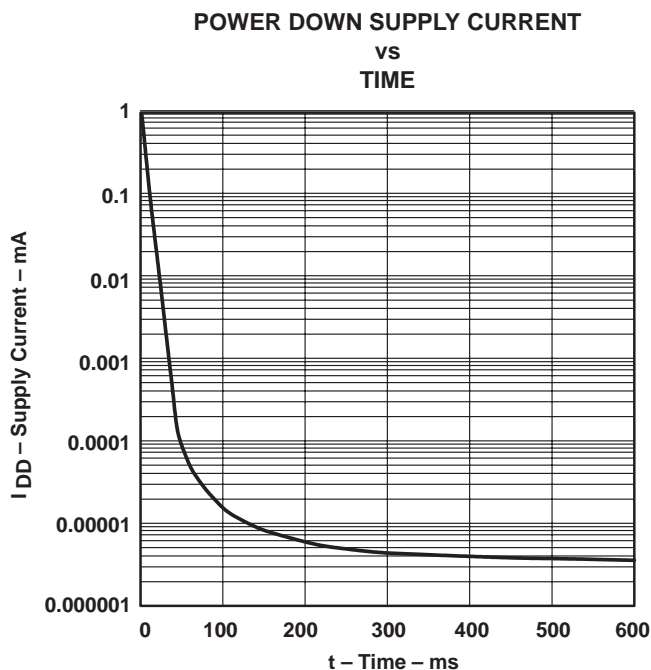

Figure 14

**APPLICATION INFORMATION**

**general function**

The TLV5613 is a 12-bit, single supply DAC, based on a resistor string architecture. It consists of a parallel interface, speed and power down control logic, a resistor string and a rail-to-rail output buffer. The output voltage (full scale determined by reference) is given by:

$$2 \text{ REF } \frac{\text{CODE}}{0x1000} \text{ [V]}$$

Where REF is the reference voltage and CODE is the digital input value, range 0x000 to 0xFFFF. A power on reset initially puts the internal latches to a defined state (all bits zero).

**parallel interface**

The device latches data on the positive edge of  $\overline{WE}$ . It must be enabled with  $\overline{CS}$  low. Whether the data is written to one of the DAC holding latches (MSW, LSW) or the control register, depends on the address bits A1 and A0.  $\overline{LDAC}$  low updates the DAC with the value in the holding latch.  $\overline{LDAC}$  is an asynchronous input and can be held low, if a separate update is not necessary. Two more asynchronous inputs, SPD and  $\overline{PWD}$  control the settling times and the power down mode:

SPD:	Speed control	1 → fast mode	0 → slow mode
PWD:	Power control	1 → normal operation	0 → power down



**TLV5613**  
**2.7 V TO 5.5 V 12-BIT PARALLEL DIGITAL-TO-ANALOG CONVERTER**  
**WITH POWER DOWN**

SLAS174A – DECEMBER 1997 – REVISED JULY 1998

**APPLICATION INFORMATION**

It is also possible to program the different modes (fast, slow, power down) and the DAC update latch using the control register. The following tables list the possible combination of the control signals and control bits.

PIN	BIT	MODE
SPD	SPD	
0	0	Slow
0	1	Fast
1	0	Fast
1	1	Fast

PIN	BIT	POWER
PWD	PWD	
0	0	Down
0	1	Down
1	0	Normal
1	1	Down

PIN	BIT	LATCH
$\overline{\text{LDAC}}$	RLDAC	
0	0	Transparent
0	1	Transparent
1	0	Hold
1	1	Transparent

**data format**

The TLV5613 writes data either to one of the DAC holding latches or to the control register depending on the address bits A1 and A0.

**ADDRESS BITS**

A1	A0	REGISTER
0	0	DAC LSW holding
0	1	DAC MSW holding
1	0	Reserved
1	1	Control

D7	D6	D5	D4	D3	D2	D1	D0
X	X	X	X	X	RLDAC	PWD	SPD

X: Don't care

- SPD: Speed control bit      1 → fast mode                      0 → slow mode
- PWD: Power control bit    1 → power down                      0 → normal operation
- RLDAC: Load DAC latch   1 → latch transparent              0 → DAC latch controlled by  $\overline{\text{LDAC}}$  pin



## APPLICATION INFORMATION

### layout considerations

To achieve the best performance, it is recommended to have separate power planes for GND,  $AV_{DD}$ , and  $DV_{DD}$ . Figure 15 shows how to lay out the power planes for the TLV5613. As a general rule, digital and analog signals should be separated as wide as possible. To avoid crosstalk, analog and digital traces must not be routed in parallel. The two positive power planes ( $AV_{DD}$  and  $DV_{DD}$ ) should be connected together at one point with a ferrite bead.

A 100-nF ceramic low series inductance capacitor between  $DV_{DD}$  and GND and a 1- $\mu$ F tantalum capacitor between  $AV_{DD}$  and GND as close as possible to the supply pins are recommended for optimal performance.

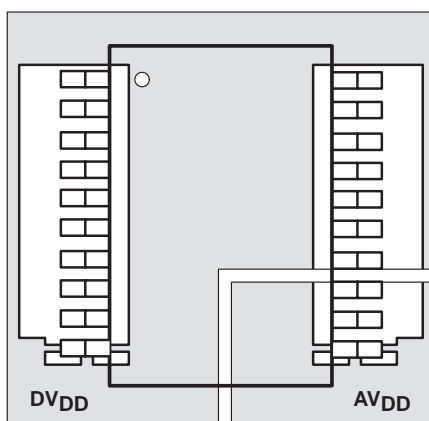

**Figure 15. TLV5613 Board Layout**

### linearity, offset, and gain error using single end supplies

When an amplifier is operated from a single supply, the voltage offset can still be either positive or negative. With a positive offset, the output voltage changes on the first code change. With a negative offset the output voltage may not change with the first code depending on the magnitude of the offset voltage.

The output amplifier attempts to drive the output to a negative voltage. However, because the most negative supply rail is ground, the output cannot drive below ground and clamps the output at 0 V.

The output voltage remains at zero until the input code value produces a sufficient positive output voltage to overcome the negative offset voltage, resulting in the transfer function shown in Figure 16.

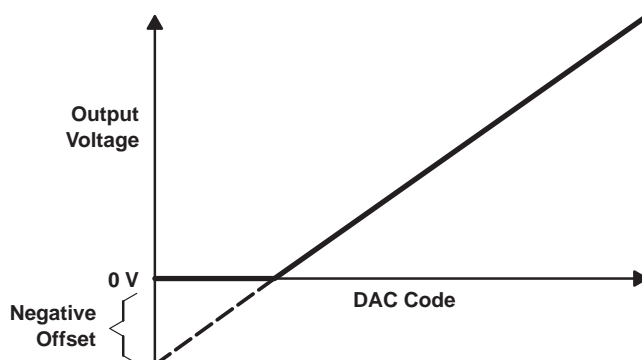

**Figure 16. Effect of Negative Offset (Single Supply)**

# TLV5613

## 2.7 V TO 5.5 V 12-BIT PARALLEL DIGITAL-TO-ANALOG CONVERTER WITH POWER DOWN

SLAS174A – DECEMBER 1997 – REVISED JULY 1998

### APPLICATION INFORMATION

This offset error, not the linearity error, produces this breakpoint. The transfer function would have followed the dotted line if the output buffer could drive below the ground rail.

For a DAC, linearity is measured between zero input code (all inputs 0) and full scale code (all inputs 1) after offset and full scale are adjusted out or accounted for in some way. However, single supply operation does not allow for adjustment when the offset is negative due to the breakpoint in the transfer function. So the linearity is measured between full scale code and the lowest code that produces a positive output voltage.

### TLV5613 interfaced to an Intel MCS<sup>®</sup>251 controller

The circuit in Figure 17 shows how to interface the TLV5613 to an Intel MCS<sup>®</sup>251 microcontroller. The address bus and the data bus of the controller are multiplexed on port 0 (non page mode) to save port pins. To separate the address bits and the data bits, the controller provides a dedicated signal, address latch enable (ALE), which is connected to a latch at port 0.

An address decoder is required to generate the chip select signal for the TLV5613. In this example, a simple 3-to-8 decoder (74AC138) is used for the interface as shown in Figure 17. The DAC is memory mapped at addresses 0x8000/1/2/3 within the data memory address space and mirrored every 32 address locations (0x8020/1/2/3, 0x8040/1/2/3, etc.). In a typical microcontroller system, programmable logic should be used to generate the chip select signals for the entire system.

The data pins and the  $\overline{WE}$  pin of the TLV5613 can be connected directly to the multiplexed address and data bus and the  $\overline{WR}$  signal of the controller.

$\overline{LDAC}$  is held high so that the output voltage is updated using the RLDAC bit in the control register. Hardware power down mode is deactivated permanently by pulling  $\overline{PWD}$  to  $DV_{DD}$ .

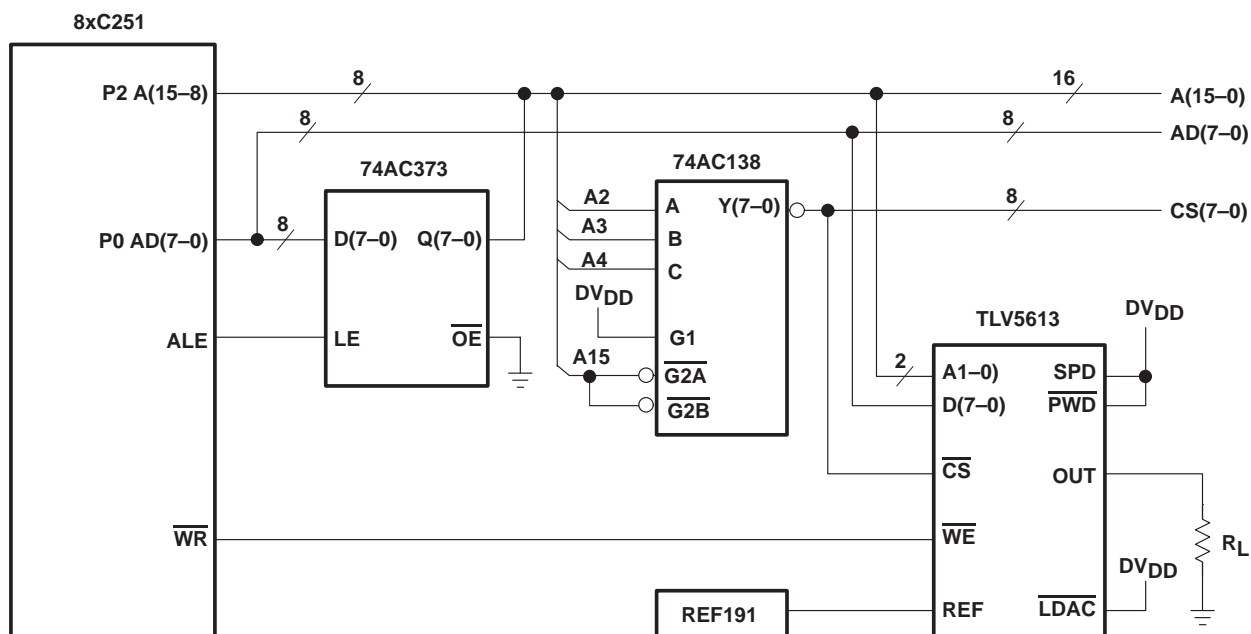

Figure 17. TLV5613 Interfaced to an Intel MCS<sup>®</sup>251 Controller

MCS is a registered trademark of Intel Corporation.



POST OFFICE BOX 655303 • DALLAS, TEXAS 75265

# TLV5613 2.7 V TO 5.5 V 12-BIT PARALLEL DIGITAL-TO-ANALOG CONVERTER WITH POWER DOWN

SLAS174A – DECEMBER 1997 – REVISED JULY 1998

## APPLICATION INFORMATION

### software

In the following example, the code generates a waveform at 500 KSPS with 500 samples stored in a table within the program memory space of the microcontroller. The period of the waveform is 1 ms.

The waveform data is located in the program memory space from address 01000h to address 013E8h ( $2 \times 500 = 1000 = 03E8h$ ) beginning with the MSW of the first 16-bit word (the 4 MSBs are ignored), followed by the LSW. Two bytes are required for each DAC word (the table is not shown in the code example).

The program consists of two parts:

- A main routine, which is executed after reset and which initializes the timer and the interrupt system of the microcontroller.
- An interrupt service routine, which reads a new value from the waveform table and writes it to the DAC.

This example uses timer 0 in mode 3 (8-bit timer with auto reload). The clock of the timer is derived from the system clock and has a frequency of  $f_{OSC}/12$ . The timer overrun frequency  $f_{tim}$  is given by the following equation:

$$f_{tim} = \frac{f_{OSC}}{12(256-Reload)} \text{ and the reload value is given by } Reload = 256 - \frac{f_{OSC}}{12 f_{tim}}$$

To get a timer overrun frequency of 500 kHz at a system clock of 24 MHz, the reload value is:

$$Reload = 256 - \frac{24}{12 \times 0.5} = 256 - 4 = 252 = 0FCh$$

With this value, the timer generates an interrupt every 2  $\mu$ s. The corresponding service routine `T0_isr` reads a sample from program memory and writes it to the DAC. First, it disables the update of the DAC output by clearing the RLDAC bit in the control register. Then it reads the MSW and the LSW from the waveform table and stores it in the MSW and LSW register of the TLV5613. The write cycle is completed by setting the RLDAC bit, which updates the DAC output. At the end of the interrupt service routine, the pointer to the waveform samples is increased and is checked to determine if it has reached the end of the table. If the pointer has reached the end of the table, the pointer is set to the start address of the table.



**TLV5613**  
**2.7 V TO 5.5 V 12-BIT PARALLEL DIGITAL-TO-ANALOG CONVERTER**  
**WITH POWER DOWN**

SLAS174A – DECEMBER 1997 – REVISED JULY 1998

**APPLICATION INFORMATION**

```

;*****
;* Title   : Waveform generation with TLV5613          *
;* Version: 1.0                                       *
;* MCU     : Intel MCS®251, MCS®51                   *
;* © 1998 Texas Instruments Inc.                     *
;*****

TABLE_START EQU 01000h      ;start address of waveform data
TABLE_END_H EQU 013h        ;high byte - end address of waveform data
TABLE_END_L EQU 0E8h        ;low byte - end address of waveform data
RELOAD      EQU 0FCh        ;timer reload value

                ORG 00000h      ;entry point
                JMP main        ;jump to main program
                ORG 0000bh      ;timer0 (T0) interrupt vector
                JMP T0_isr      ;jump to T0 interrupt service routine

;-----
;main: setup timer and interrupt, loop forever
;-----

main:          CLR A
              MOV A, IE0        ;disable all interrupts
              CLR TCON.4        ;stop T0
              MOV A, #002h
              MOV TMOD, A        ;set T0 to auto reload mode
              MOV A, #RELOAD
              MOV TH0, A        ;set T0 reload value
              MOV TL0, A        ;set T0 start value
              MOV P2, #080h      ;set A15 of address bus to select DAC

              MOV DPTR, #TABLE_START ;set data pointer to start of wave form data

              SETB IE0.1        ;enable T0 interrupt
              SETB IE0.7        ;enable interrupts
              SETB TCON.4        ;start T0

idle_loop:    SJMP idle_loop    ;loop forever

```



POST OFFICE BOX 655303 • DALLAS, TEXAS 75265



TLV5613  
2.7 V TO 5.5 V 12-BIT PARALLEL DIGITAL-TO-ANALOG CONVERTER  
WITH POWER DOWN

SLAS174A – DECEMBER 1997 – REVISED JULY 1998

---

**APPLICATION INFORMATION**

```
-----  
;T0_isr: will be called on every timer interrupt.  
;fetches a new 16-bit value from program memory space and writes it  
;to the DAC. If end of table is reached, sets DPTR to table start addr.  
-----  
T0_isr:      MOV R0, #003h          ;select DAC control register  
             MOV A, #001h          ;RLDAC=0, PWD=0, SPD=1  
                                     ;no DAC update, normal operation, fast mode  
             MOVX @R0, A           ;write Accu to DAC control register  
  
             MOV R0, #001h          ;select DAC MSW register  
             CLR A  
             MOVC A, @A+DPTR        ;get MSW from code memory  
             MOVX @R0, A           ;write Accu to DAC MSW register  
  
             INC DPTR              ;set DPTR to LSW data  
  
             MOV R0, #000h          ;select DAC LSW register  
             CLR A  
             MOVC A, @A+DPTR        ;get LSW from code memory  
             MOVX @R0, A           ;write Accu to DAC LSW register  
  
             MOV R0, #003h          ;select DAC control register (to update DAC)  
             MOV A, #005h          ;DAC update, normal operation, fast mode  
             MOVX @R0, A           ;write Accu to DAC control register  
  
             INC DPTR              ;set DPTR to next MSW  
                                     ;test end of table  
  
             MOV A, DPL  
             CJNE A, #TABLE_END_L, T0_isr_end  
             MOV A, DPH  
             CJNE A, #TABLE_END_H, T0_isr_end  
             MOV DPTR, #TABLE_START ;end of table reached -> start again  
T0_isr_end: RETI  
  
             END
```



# TLV5613

## 2.7 V TO 5.5 V 12-BIT PARALLEL DIGITAL-TO-ANALOG CONVERTER WITH POWER DOWN

SLAS174A – DECEMBER 1997 – REVISED JULY 1998

---

### APPLICATION INFORMATION

#### definitions of specifications and terminology

##### integral nonlinearity (INL)

The relative accuracy or integral nonlinearity (INL), sometimes referred to as linearity error, is the maximum deviation of the output from the line between zero and full scale excluding the effects of zero code and full-scale errors.

##### differential nonlinearity (DNL)

The differential nonlinearity (DNL), sometimes referred to as differential error, is the difference between the measured and ideal 1 LSB amplitude change of any two adjacent codes. Monotonic means the output voltage changes in the same direction (or remains constant) as a change in the digital input code.

##### zero-scale error ( $E_{ZS}$ )

Zero-scale error is defined as the deviation of the output from 0 V at a digital input value of 0.

##### gain error ( $E_G$ )

Gain error is the error in slope of the DAC transfer function.

##### signal-to-noise ratio + distortion (SINAD)

Signal-to-noise ratio + distortion is the ratio of the rms value of the output signal to the rms sum of all other spectral components below the Nyquist frequency, including harmonics but excluding dc. The value for SINAD is expressed in decibels.

##### spurious free dynamic range (SFDR)

Spurious free dynamic range is the difference between the rms value of the output signal and the rms value of the spurious signal within a specified bandwidth. The value for SFDR is expressed in decibels.

##### total harmonic distortion (THD)

Total harmonic distortion is the ratio of the rms sum of the first six harmonic components to the rms value of the fundamental signal and is expressed in decibels.



# TLV5613

## 2.7 V TO 5.5 V 12-BIT PARALLEL DIGITAL-TO-ANALOG CONVERTER WITH POWER DOWN

SLAS174A – DECEMBER 1997 – REVISED JULY 1998

### MECHANICAL DATA

DW (R-PDSO-G\*\*)

PLASTIC SMALL-OUTLINE PACKAGE

16 PIN SHOWN

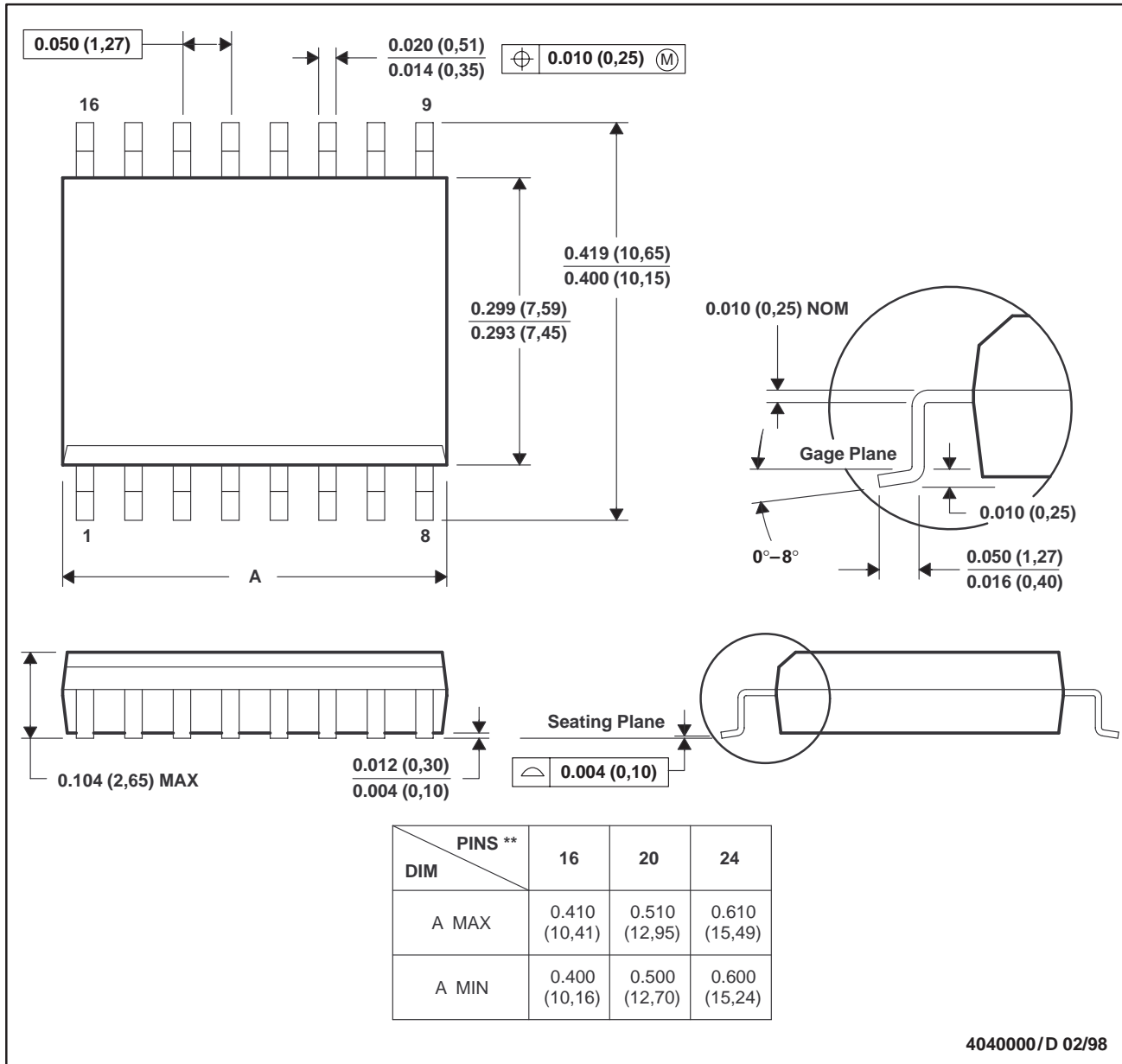

- NOTES: A. All linear dimensions are in inches (millimeters).  
 B. This drawing is subject to change without notice.  
 C. Body dimensions do not include mold flash or protrusion not to exceed 0.006 (0,15).  
 D. Falls within JEDEC MS-013



**TLV5613**  
**2.7 V TO 5.5 V 12-BIT PARALLEL DIGITAL-TO-ANALOG CONVERTER**  
**WITH POWER DOWN**

SLAS174A – DECEMBER 1997 – REVISED JULY 1998

**PW (R-PDSO-G\*\*)**

**PLASTIC SMALL-OUTLINE PACKAGE**

14 PIN SHOWN

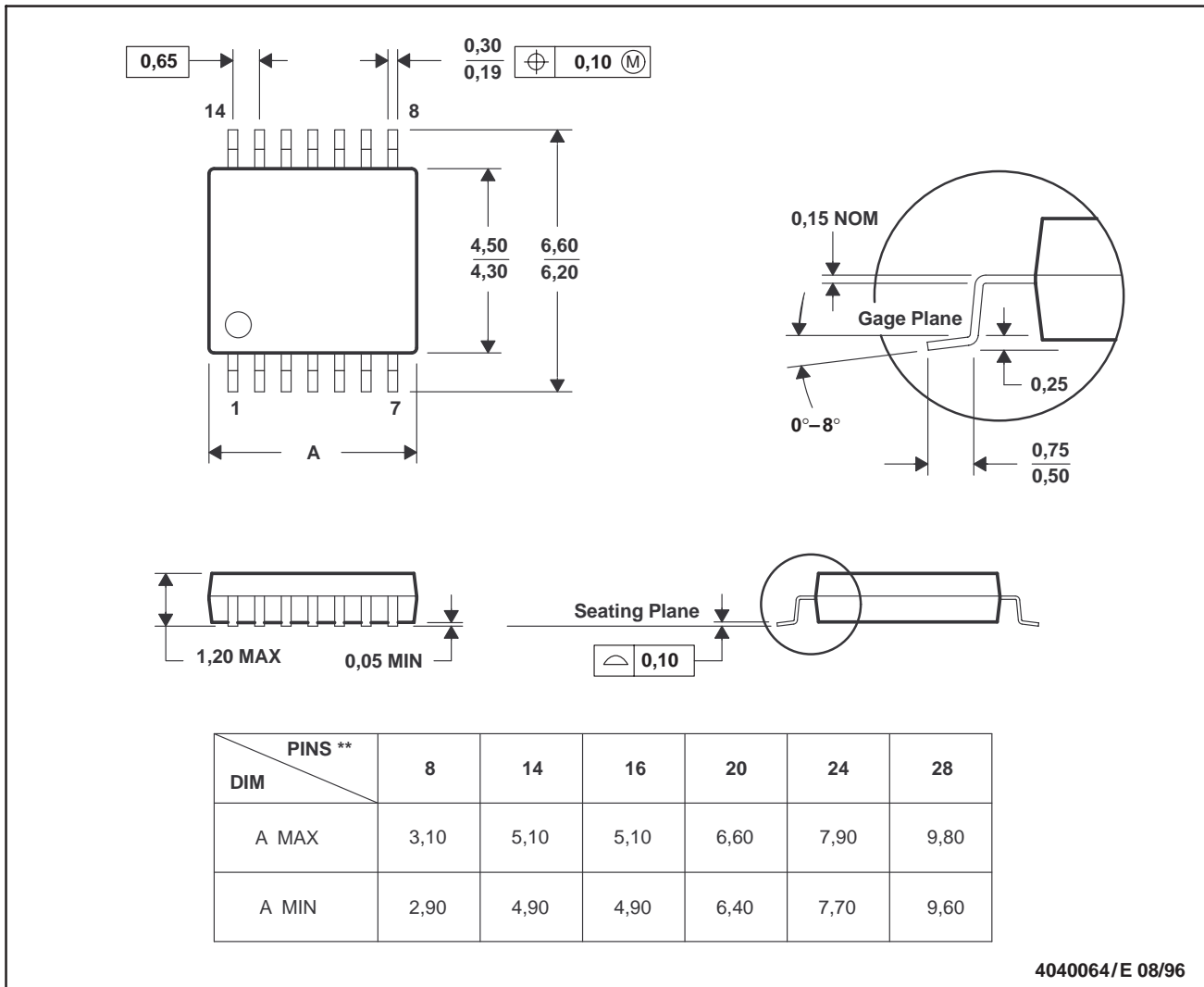

4040064/E 08/96

- NOTES: A. All linear dimensions are in millimeters.  
 B. This drawing is subject to change without notice.  
 C. Body dimensions do not include mold flash or protrusion not to exceed 0,15.  
 D. Falls within JEDEC MO-153

## **IMPORTANT NOTICE**

Texas Instruments and its subsidiaries (TI) reserve the right to make changes to their products or to discontinue any product or service without notice, and advise customers to obtain the latest version of relevant information to verify, before placing orders, that information being relied on is current and complete. All products are sold subject to the terms and conditions of sale supplied at the time of order acknowledgement, including those pertaining to warranty, patent infringement, and limitation of liability.

TI warrants performance of its semiconductor products to the specifications applicable at the time of sale in accordance with TI's standard warranty. Testing and other quality control techniques are utilized to the extent TI deems necessary to support this warranty. Specific testing of all parameters of each device is not necessarily performed, except those mandated by government requirements.

CERTAIN APPLICATIONS USING SEMICONDUCTOR PRODUCTS MAY INVOLVE POTENTIAL RISKS OF DEATH, PERSONAL INJURY, OR SEVERE PROPERTY OR ENVIRONMENTAL DAMAGE ("CRITICAL APPLICATIONS"). TI SEMICONDUCTOR PRODUCTS ARE NOT DESIGNED, AUTHORIZED, OR WARRANTED TO BE SUITABLE FOR USE IN LIFE-SUPPORT DEVICES OR SYSTEMS OR OTHER CRITICAL APPLICATIONS. INCLUSION OF TI PRODUCTS IN SUCH APPLICATIONS IS UNDERSTOOD TO BE FULLY AT THE CUSTOMER'S RISK.

In order to minimize risks associated with the customer's applications, adequate design and operating safeguards must be provided by the customer to minimize inherent or procedural hazards.

TI assumes no liability for applications assistance or customer product design. TI does not warrant or represent that any license, either express or implied, is granted under any patent right, copyright, mask work right, or other intellectual property right of TI covering or relating to any combination, machine, or process in which such semiconductor products or services might be or are used. TI's publication of information regarding any third party's products or services does not constitute TI's approval, warranty or endorsement thereof.